

DBL 2019

LINEAR R.G.B PROCESSOR FOR MONITOR/DISPLAY APPLICATION

The DBL 2019 is a linear RGB signal processor designed for a monitor or for display application. Brightness control is possible in both CRT driving circuits, a direct coupling circuit, or an AC coupling circuit.

FUNCTION

- Contrast control
- Blanking pulse amplitude adjustment
- Clamping circuit
- DC Feedback (DC restoration)
- Brightness control
- ACL circuit

FEATURES

- 60MHz RGB signal band width(Typ.)
- AC coupling CRT driving circuit (peak clamp construction) : Adjustable blanking pulse amplitude and clamping pulse input applied.
- Direct coupling CRT driving circuit : pedestal clamp : also equipped with DC Feedback Circuit.

MAXIMUM RATINGS(Ta=25°C)

Characteristic	Symbol	Rating	Unit
Power Supply Voltage	$V_{CC} - V_{EE}$	15	V
Terminal 2 Voltage	V_2	$0 \sim V_{CC}$	V
Terminals 6, 9, 12, and 7, 10, 13 Voltage	V_6, V_9, V_{12} V_7, V_{10}, V_{13}	$V_{EE} \sim V_{CC}$	V
Terminals 4 and 8 Voltage	$V_{CC} \sim V_4, V_{CC} \sim V_8$	10	V
Terminals 16, 21, and 25 Voltage	V_{16}, V_{21}, V_{25}	$V_{EE} \sim 5$	V

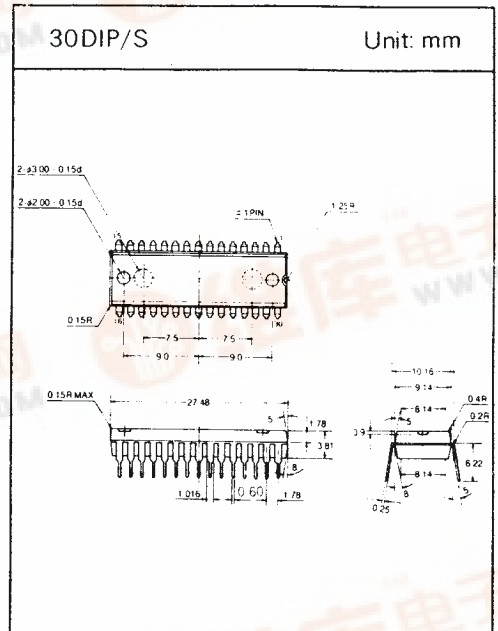

MAXIMUM RATINGS(Continued)

Characteristic	Symbol	Rating	Unit
Terminals 17, 22, and 27 Source Current	I_{17}, I_{22}, I_{27}	10	mA
Terminals 17, 22, and 27 Voltage	V_{17}, V_{22}, V_{27}	V_{CC}	V
Terminals 20, 23, 28 and 29 Voltage	$V_{20}, V_{23}, V_{28}, V_{29}$	0~5	V
Terminal 30 Voltage	V_{30}	0~ V_{CC}	V
Power Dissipation	$P_{D\ MAX}$	1.6	W
Operating Temperature	T_{opr}	-20~+65	°C
Storage Temperature	T_{stg}	-55~+150	°C

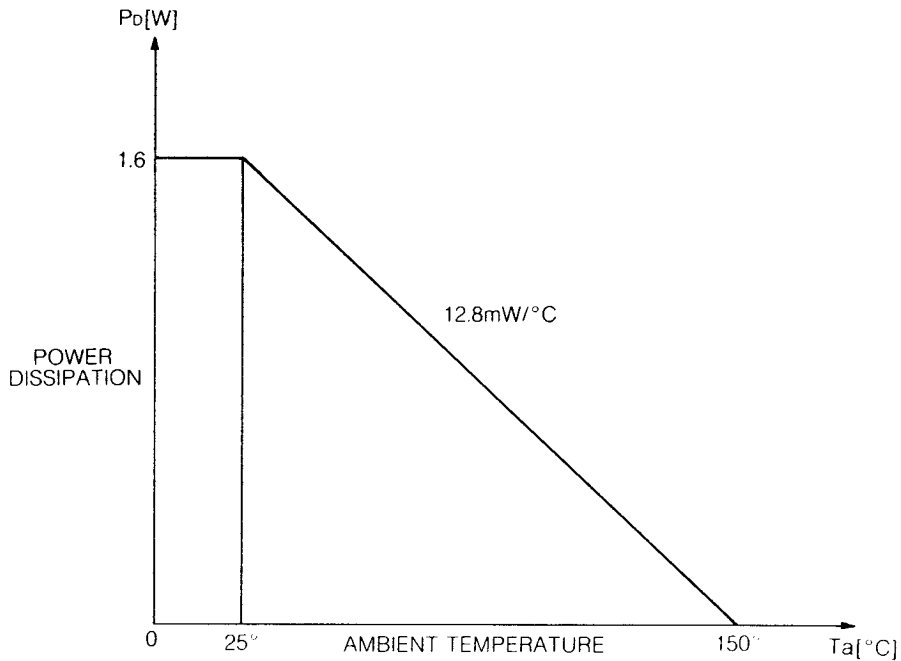

□ BLOCK DIAGRAM

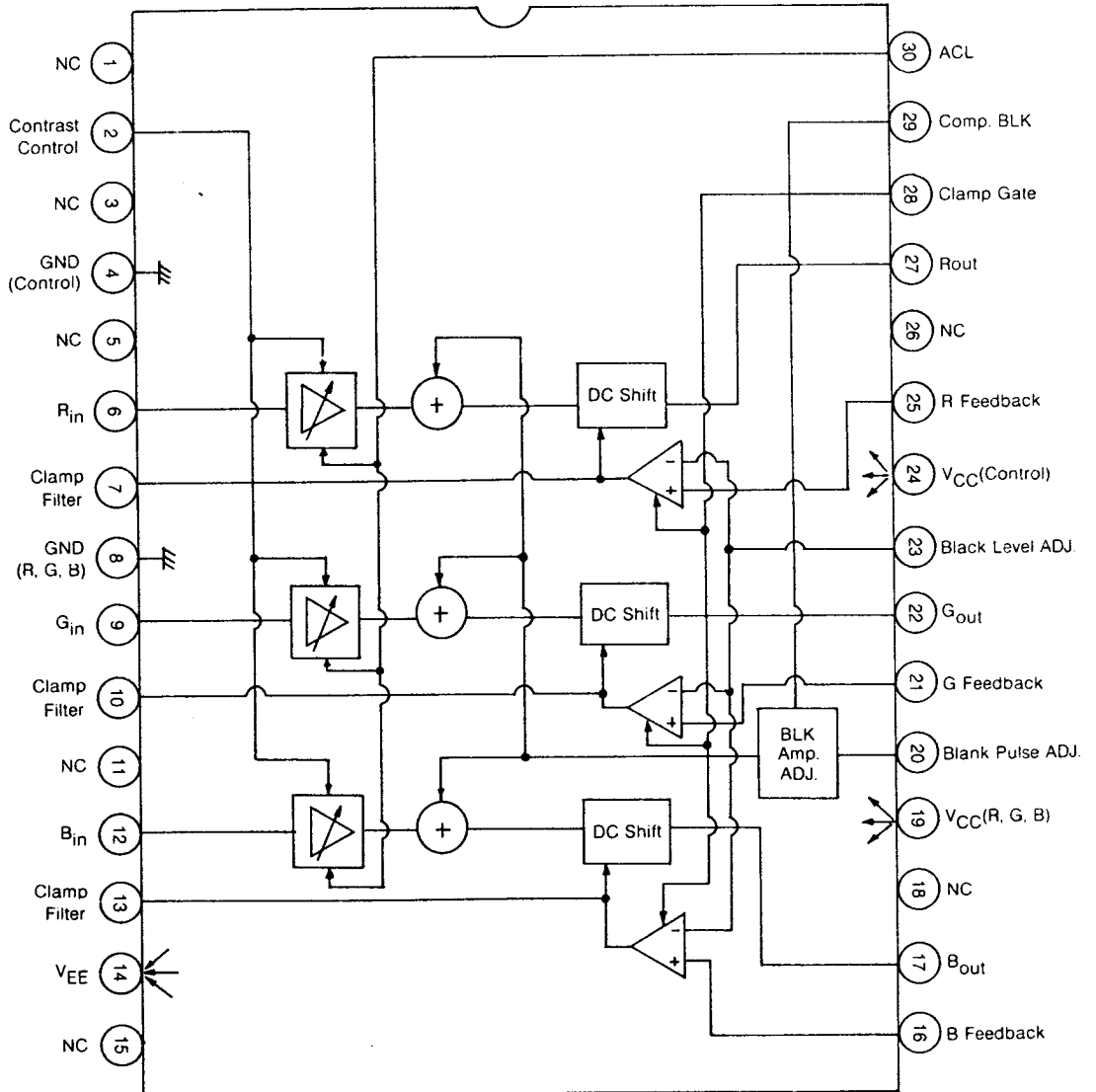

□ AC TEST CIRCUIT 1

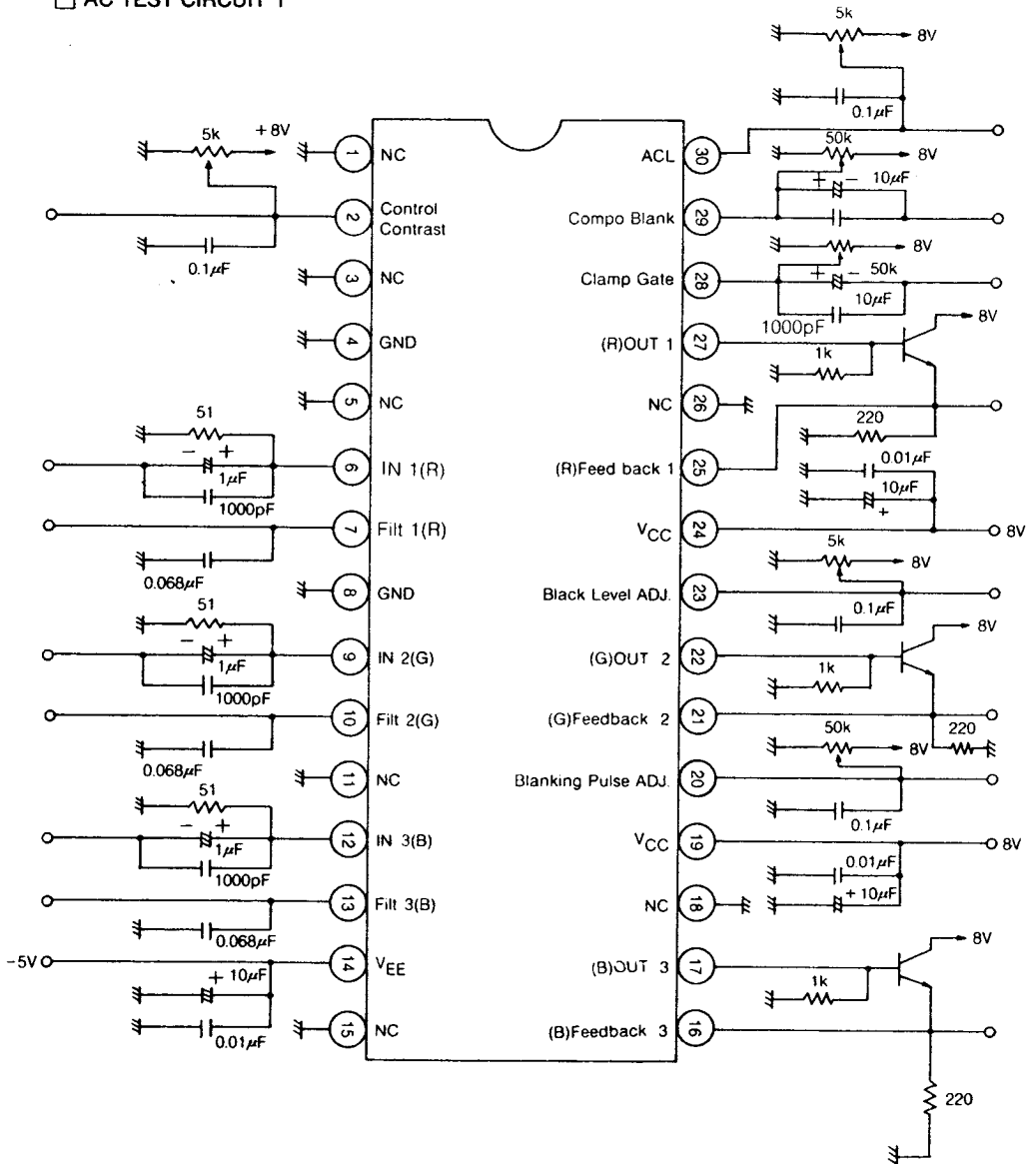

DBL 2019

□ ELECTRICAL CHARACTERISTICS (Ta=25°C ±1.5°C, V_{CC} =8V, V_{EE} = -5V)

Characteristic	Symbol	Test Circuit	Test Condition	Min.	Typ.	Max.	Unit
Recommended Supply Voltage	#19, 24 V _{CC}	1	—	7.2	8	8.8	V
	#14 V _{EE}		—	-5.5	-5	-4.5	
Supply Current	#24 I _{CC24}			7	9	13	
	#19 I _{CC19}	1	NOTE 1)	34	45	64	mA
	#14 I _{EE14}			30	39	56	
Input Signal Dynamic Range	V ₆₊ , V ₉₊ , V ₁₂₊			1.4	1.5	1.6	V
	V ₆₋ , V ₉₋ , V ₁₂₋	1	NOTE 2)	-0.8	-1	-1.2	V
	V ₆ , V ₉ , V ₁₂			—	0.7	1	V _{P-P}
Output Amplitude	v _o	1	NOTE 2)	—	5	—	V _{P-P}
Maximum Gain	G _m	1	NOTE 3)	11.5	12.5	13.5	dB
Contrast Range	R _{CONT}	1	V ₂ = 6V → V ₂ = 1V	12	—	—	dB
Contrast Tracking	TR _{CONT}	1	NOTE 4)	—	±2	±3	dB
Blanking Pulse Adjustable Range	V _{BLK MAX}	1	NOTE 5)	-0.1	0	0.1	V _{P-P}
	V _{BLK MIN}			0.8	1	1.2	
Blanking Pulse Tracking	TR _{BLK}	1	NOTE 6)	—	—	±50	mV _{P-P}
Blanking Pulse H LEVEL	V _{H BLK}	1	—	3.5	—	V _{CC} - 2	V
	V _{L BLK}			-0.4	—	2.5	
Blanking Pulse Delay Time	τ _{BLK}	1	—	—	50	100	nsec
Blanking Pulse Range	R _{BLK}	1	NOTE 5)	1.9	2.2	2.5	V
Black Level Control Range	R _{BL}	1	NOTE 7)	0.1	—	4	V
R.G.B Black Level Difference	ΔV _{BL}	1	NOTE 8)	—	—	±50	mV
Black Level Temperature Drift	ΔT _{BL}	1	NOTE 9)	—	0	±1	mV/°C
ACL Threshold Voltage Gain	V _{TH ACL} G _{ACL}	1	NOTE 10)	5.9	6.3	6.6	V dB/V
R.G.B Frequency Response	f _{BW}	1	NOTE 11)	—	45	—	MHz

ELECTRICAL CHARACTERISTICS(Continued)

Characteristic	Symbol	Test Circuit	Test Condition	Min.	Typ.	Max.	Unit
Response Ripple	R	1	0 10 10 MHz 10 MHz to 30 MHz	— —	— 2.5	±0.5 3.5	dB
R.G.B Gain Difference	ΔG	1	Contrast Max. 0 to 10 MHz 10 MHz to 30 MHz	— —	±5 ±20	±15 ±25	%
Crosstalk between Channels	CT	1	0 to 10 MHz 10 MHz to 30 MHz	— —	— —	-40 -25	dB
Contrast Deviation at High Frequency	D_{CONT}	1	Contrast -12 dB 0 to 10 MHz 10 MHz to 30 MHz	— —	±2 ±3	±3 —	dB
R.G.B Output Impedance	Z_o	1	—	—	50	100	Ω

TEST CONDITION

NOTE 1) ABL: 8V, Contrast: 8V, Clamp Gate: 0V, Comp. Blank: 0V
Apply 3.5V DC to filter terminals.

NOTE 2) Input: 5 steps, staircase
ABL: 8V
Contrast: 8V
Clamp Gate: 5V } Pulse input

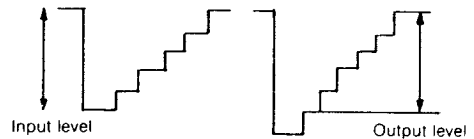

NOTE 3) Input: 0.5Vp-p, 500 kHz sinusoidal wave
ABL: 8V
Contrast: 8V
Clamp Gate: 4V
Comp. Blank: 2V
Black Adj.: 3V

NOTE 4) Conditions are the same as NOTE 3), except for contrast control Voltage.
Adjust contrast control so that the contrast of R channel will be -12 dB of the maximum.
Measure contrast tracking of G and B channels.

DBL 2019

TEST CONDITION(Continued)

NOTE 5) Apply DC voltage to filter terminals so that the output level becomes 3V.

Then turn off composite blanking.

Measure the outputs DC level after changing blanking adj. (Clamp Gate: 2V)

NOTE 6) Refer to NOTE 5).

Tracking of blanking pulse when blanking adj. is 2V.

NOTE 7) #23 voltage range which #17, 22, and 27 voltage track the change.

NOTE 8) Black level differences between channels when black level is changed from. 0.1V to 4V.

NOTE 9) Clamp Gate: 4V, Black Adj.: 0.5V($T_a = 25^\circ\text{C}$)

Change T_a -20°C to $+70^\circ\text{C}$; then measure output voltage changes.

NOTE 10) Input: 0.5V_{p-p} 500 kHz

Contrast: 8V

Black Adj.: 3V

Clamp Gate: 4V

Comp. Blank: 2V

NOTE 11) ABL: 8V

Comp. Blank: 2V

Clamp Gate: 4V

Black Adj.: 3.7V

Contrast(Max. Gain, -6 dB, -12 dB)

□ TYPICAL PERFORMANCE CHARACTERISTICS

ELECTRICAL CHARACTERISTICS

FREQUENCY RESPONSE

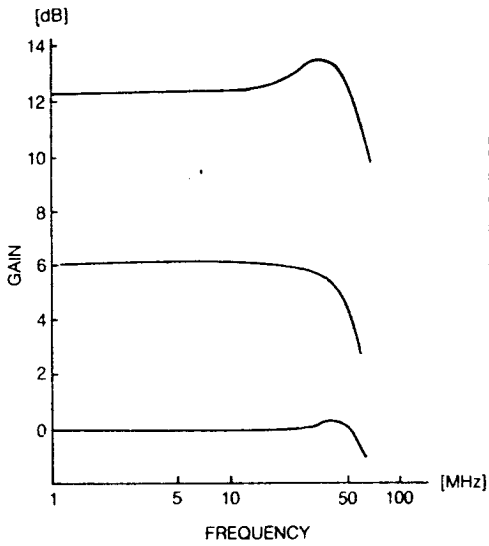

CONTRAST CONTROL CHARACTERISTICS

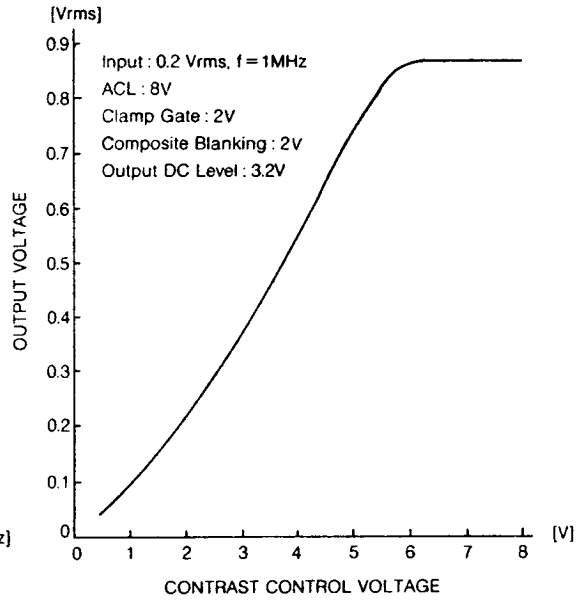

ACL CHARACTERISTICS

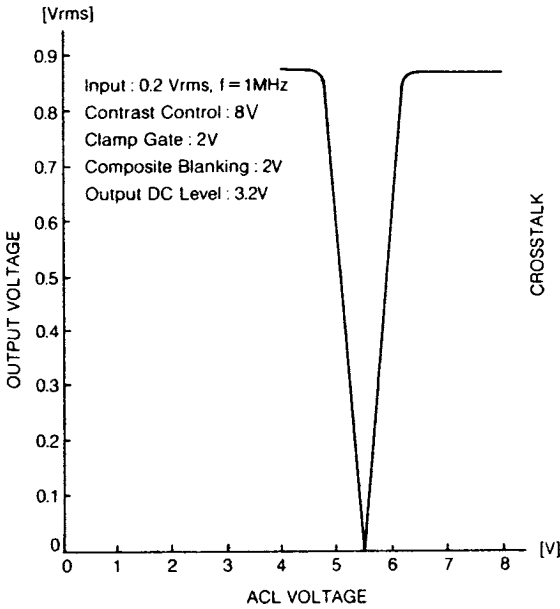

CROSSTALK BETWEEN CHANNELS
FREQUENCY

