



DDC101

20-BIT ANALOG-TO-DIGITAL CONVERTER

FEATURES

- MONOLITHIC CHARGE INPUT ADC
- DIGITAL FILTER NOISE REDUCTION: 0.9ppm, rms
- DIGITAL ERROR CORRECTION: CDS
- CONVERSION RATE: Up to 15kHz
- USER FRIENDLY EVALUATION FIXTURE

APPLICATIONS

- DIRECT PHOTODIODE DIGITIZATION
- PRECISION INSTRUMENTATION
- INFRARED PYROMETRY
- PRECISION PROCESS CONTROL
- CT SCANNER DAS
- CHEMICAL ANALYZERS

DESCRIPTION

The DDC101 is a precision, wide dynamic range, charge digitizing A/D converter with 20-bit resolution. Low level current output devices, such as photodiodes, can be directly connected to its input. The most stringent accuracy requirements of many unipolar output sensor applications occur at low signal levels. To meet this requirement, Burr-Brown developed the adaptive delta modulation architecture of the DDC101 to provide linearly improving noise and linearity errors as the input signal level decreases. The DDC101 combines the functions of current-to-voltage conversion, integration, input programmable gain amplification, A/D conversion, and digital filtering to produce precision, wide dynamic range results. The input signal can be a low level current connected directly into the unit or a voltage connected through a user selected resistor. Although the DDC101 is optimized for unipolar signals, it can also accurately digitize bipolar input signals. The patented delta modulation

topology combines charge integration and digitization functions. Oversampling and digital filtering reduce system noise dramatically. Correlated Double Sampling (CDS) captures and eliminates steady state and conversion cycle dependent offset and switching errors that are not eliminated with conventional analog circuits.

The DDC101 block diagram is shown below. During conversion, the input signal is collected on the internal integration capacitance for a user determined integration period. A high precision, autozeroed comparator samples the analog input node. Tracking logic updates the internal high resolution D/A converter at a 2MHz rate to maintain the analog input at virtual ground. A user programmable digital filter oversamples the tracking logic's output. The digital filter passes a low noise, high resolution digital output to the serial I/O register. The serial outputs of multiple DDC101 units can be easily connected together in series or parallel if desired to minimize interconnections.

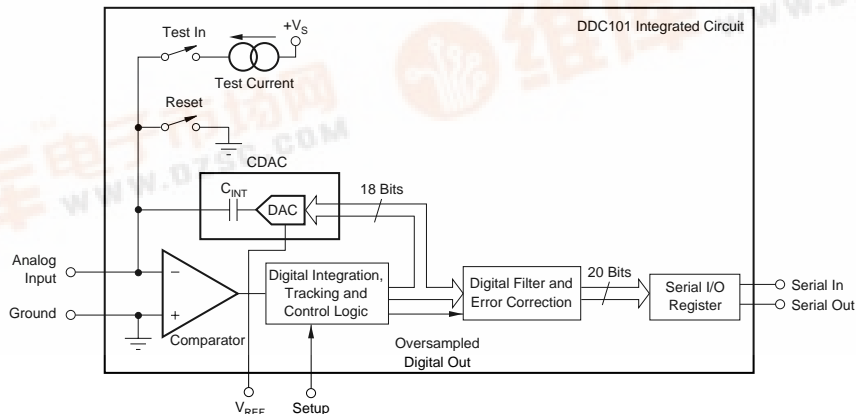

TABLE OF CONTENTS

- Section 1 Basic Theory of Operation
- 2 Specifications
- 3 Pin Descriptions
- 4 Timing Diagrams
- 5 Discussion of Specifications
- 6 Detailed Theory of Operation
- 7 Applications Information
- 8 Mechanical

SECTION 1 BASIC THEORY OF OPERATION

The basic function of the DDC101 is illustrated in the Simplified Equivalent Circuit shown in Figure 1. The operation is equivalent to the functions performed by a very high quality, low bias current switched integrator followed by a precision floating point programmable gain amplifier and ending with a high resolution A/D converter.

The second block diagram, Figure 2, shows the DDC101 circuit architecture which implements these functions monolithically. During each conversion, the input signal current is collected on the internal integration capacitance, C_{INT} , as charge for a user determined integration period, T_{INT} . As the integration capacitor collects input charge, the tracking logic updates the internal high resolution D/A converter at a 2MHz rate to maintain the analog input node at virtual ground.

The digital filter oversamples the tracking logic's output at the beginning and end of each integration period to produce two oversampled data points. The DDC101 measures the charge accumulated in the integration and performs correlated double sampling (CDS) by subtracting these two data points. CDS eliminates integration cycle dependent errors such as charge injection, offset voltage, and reset noise since these errors are measured with the signal at each of the two data points. The number of oversamples, and thus the frequency response of the digital filter, is user programmable.

The digital filter passes a low noise, high resolution digital output to the serial I/O register. Since the timing control of the serial I/O register is independent of the DDC101 conversion process, the outputs of multiple DDC101 units can be connected together in series or parallel to minimize interconnections.

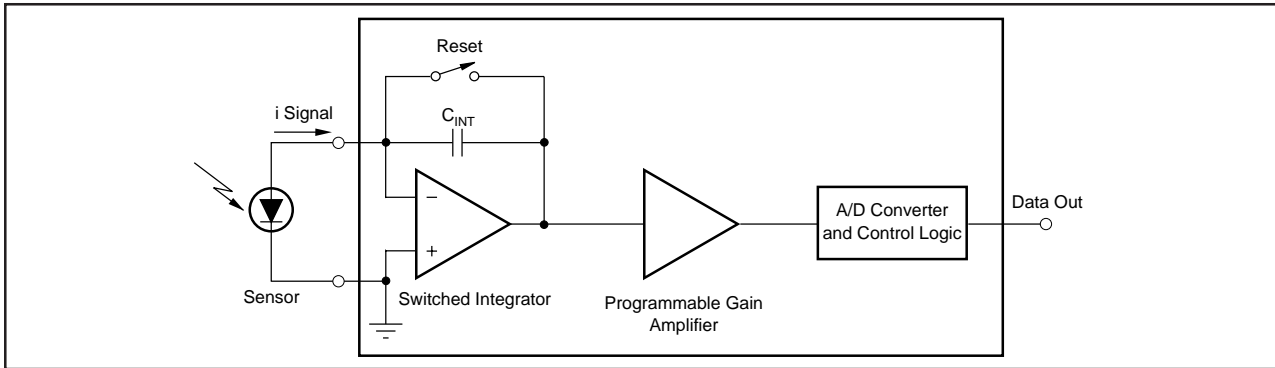

FIGURE 1. Simplified Equivalent Circuit of DDC101 to Illustrate Function.

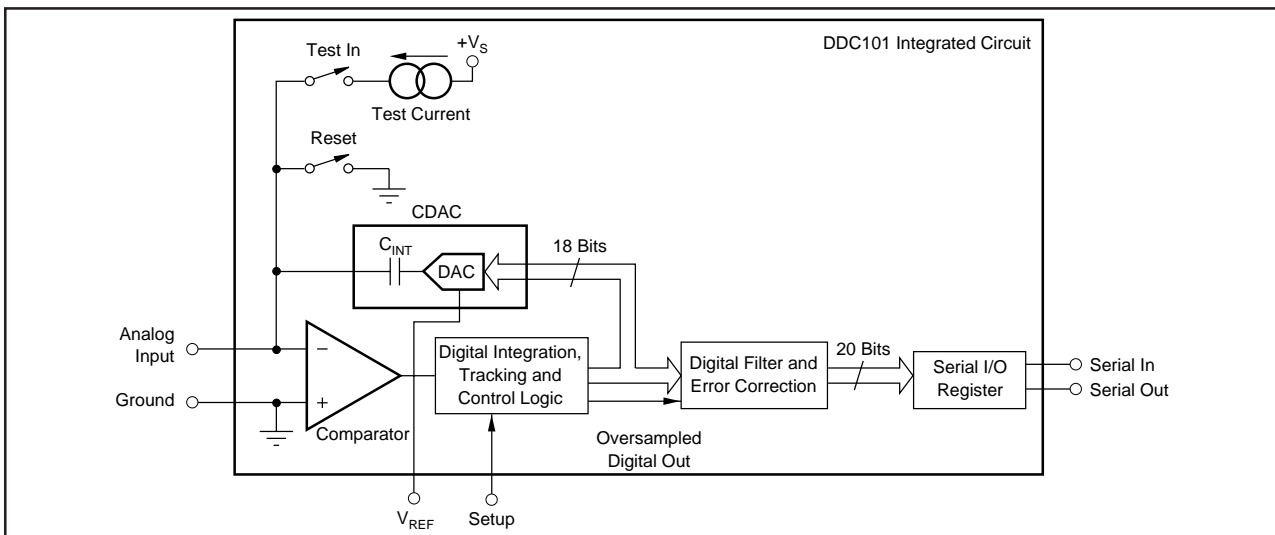

FIGURE 2. DDC101 Block Diagram.

An internal test current source is provided for basic functionality testing and diagnostics. This approximately 100nA current source is pin activated and sums with the external input current.

Capacitor Digital-to-Analog Converter (CDAC). By switching between ground and V_{REF} the binary weighted capacitor array of the CDAC accumulates the input signal's charge to keep the comparator input at virtual ground.

Figure 3 shows a more detailed circuit configuration of the DDC101. The single integration capacitor, C_{INT} , and the D/A converter have been replaced with a high resolution

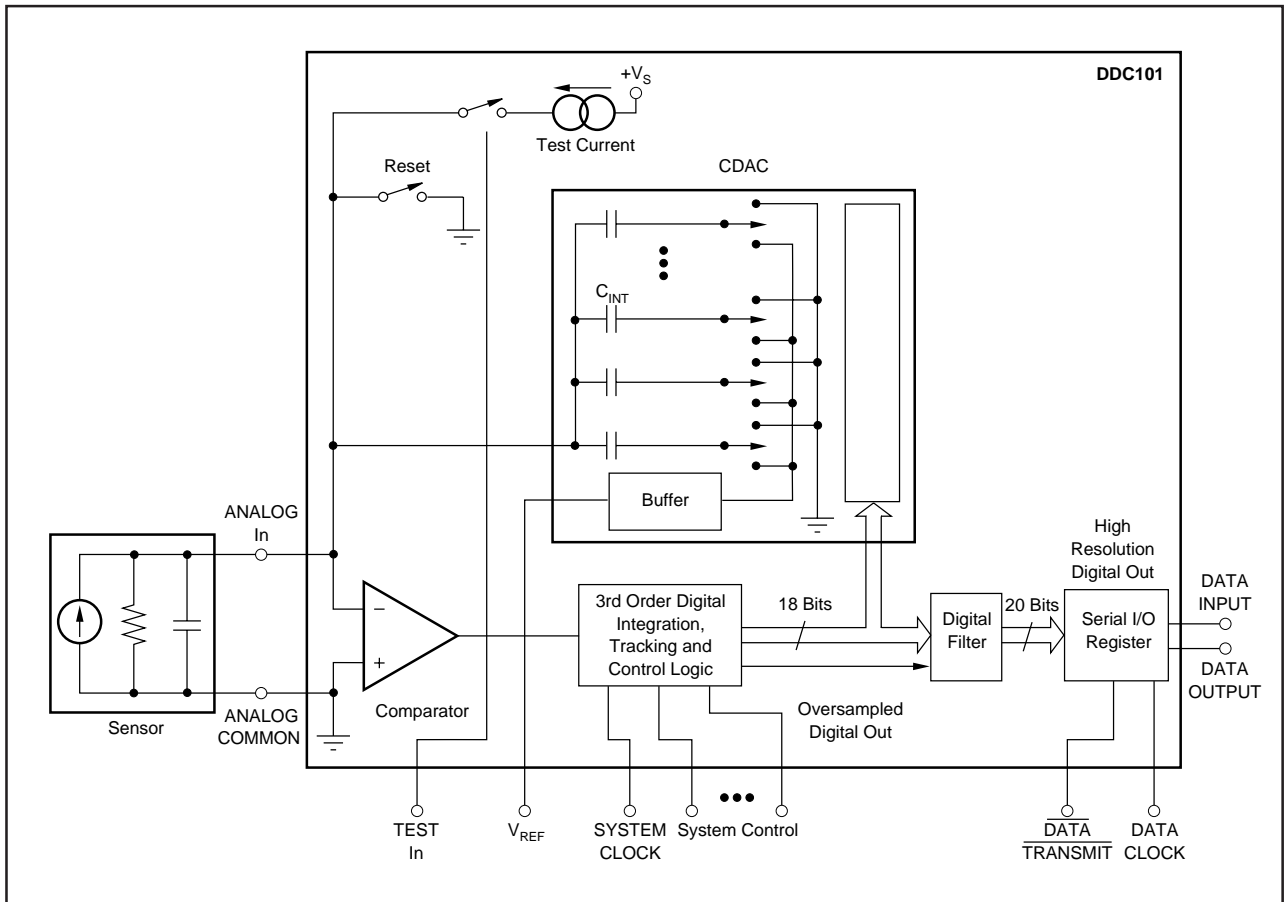

FIGURE 3. DDC101 Detailed Circuit Diagram.

The information provided herein is believed to be reliable; however, BURR-BROWN assumes no responsibility for inaccuracies or omissions. BURR-BROWN assumes no responsibility for the use of this information, and all use of such information shall be entirely at the user's own risk. Prices and specifications are subject to change without notice. No patent rights or licenses to any of the circuits described herein are implied or granted to any third party. BURR-BROWN does not authorize or warrant any BURR-BROWN product for use in life support devices and/or systems.

SECTION 2

SPECIFICATIONS

ELECTRICAL

All specifications with unipolar current input range, $T_{INT} = 1$ ms, correlated double sampling enabled, System Clock = 2MHz, $V_{REF} = -2.5V$, $T_A = +25^\circ C$ and $V_S = \pm 5VDC$, unless otherwise noted.

PARAMETER	CONDITIONS	DDC101			UNITS
		MIN	TYP	MAX	
INPUTS					
Charge Input ⁽⁶⁾					
Unipolar Input Range	BTC Output Code	-1.95		500	pC/Integration
Bipolar Input Range	BTC Output Code	-251.95		250	pC/Integration
Input Current	Unipolar or Bipolar Range			7.8	μA
Current Input Range Examples ⁽¹⁰⁾					
Unipolar Input Range	$T_{INT} = 100\mu s$	-0.0195		5	μA
Unipolar Input Range	$T_{INT} = 1$ ms	-1.95		500	nA
Bipolar Input Range	$T_{INT} = 100\mu s$	-2.5195		2.5	μA
Bipolar Input Range	$T_{INT} = 1$ ms	-251.95		250	nA
Voltage Input Examples ⁽¹⁰⁾					
Unipolar Input Range ⁽²⁾	$R_{IN} = 10M\Omega$, $T_{INT} = 1$ ms	-0.0195		5	V
Bipolar Input Range ⁽²⁾	$R_{IN} = 10M\Omega$, $T_{INT} = 1$ ms	-2.5195		2.5	V
DYNAMIC CHARACTERISTICS					
Conversion Time		64		256×10^6	μs
Integration Time		64		10^6	μs
System Clock Input		0.5		2	MHz
ACCURACY					
Unipolar Mode Noise					
Noise, Low Level Current Input ⁽¹⁾	$C_{SENSOR} = 0pF$, $L = 8$		0.9		ppm of FSR, rms ⁽³⁾
Noise, Low Level Current Input ⁽¹⁾	$C_{SENSOR} = 0pF$, $L = 1$		1.6		ppm of FSR, rms
Noise, Low Level Current Input ⁽¹⁾	$C_{SENSOR} = 100pF$, $L = 1$		2.1	3	ppm of FSR, rms
Noise, Low Level Current Input ⁽¹⁾	$C_{SENSOR} = 500pF$, $L = 1$		4.2		ppm of FSR, rms
Noise, Voltage Input ^(1,2)	$R_{IN} \geq 20M\Omega$		1.9		ppm of FSR, rms
Differential Linearity Error					
Unipolar Input Range	Entire Range			$\pm 0.005\%$ Reading ± 0.5 ppm FSR, max	
	0.1% FSR Input			± 0.00006	% of FSR
	1% FSR Input			± 0.00010	% of FSR
	10% FSR Input			± 0.00055	% of FSR
Unipolar or Bipolar Input Range				± 0.0015	% of FSR
Integral Linearity Error					
Unipolar Input Range ⁽¹¹⁾	0 to 500 pc/Integration			$\pm 0.0244\%$ Reading ± 2.5 ppm FSR, max	
	-1.95 to 0 pc/Integration			$\pm 0.0244\%$ Reading ± 3.0 ppm FSR, max	
	0.1% FSR Input			± 0.00028	% of FSR
	1% FSR Input			± 0.00050	% of FSR
	10% FSR Input			± 0.0027	% of FSR
Unipolar or Bipolar Input Range ⁽¹¹⁾				± 0.003	% of FSR
No Missing Codes					
Unipolar Input Range			18		Bits
Bipolar Input Range			16		Bits
Input Bias Current	$T_A = +25^\circ C$		3	10	pA
DC Gain Error			± 0.5	± 2	% of FSR
Output Offset Error ⁽⁸⁾			± 0.5		ppm of FSR
Input Offset Voltage ⁽⁸⁾			± 0.5	± 2	mV
External Voltage Reference, V_{REF}			-2.5		VDC
Internal Test Signal			100		nA
Internal Test Signal Accuracy			± 20		nA
Gain Sensitivity to V_{REF}	$V_{REF} = 2.5V \pm 0.1V$		1:1		
PSRR		80	90		dB
PERFORMANCE OVER TEMPERATURE					
Output Offset Drift ⁽⁸⁾	not including bias current drift		0		$\mu V/^\circ C$
Input Offset Voltage Drift ⁽⁸⁾			1		$\mu V/^\circ C$
Input Bias Current Drift	$+25^\circ C$ to $+45^\circ C$		0.1	0.5	pA/°C
Input Bias Current	$T_A = +85^\circ C$		8	40	pA
Gain Drift ⁽⁴⁾			± 15		ppm/°C
DIGITAL INPUT/OUTPUT					
Logic Family					
Logic Level: V_{IH}					
V_{IL}	$I_{IH} = +5\mu A$	+2.0		$+V_{CC}$	V
V_{OH}	$I_{IL} = +5\mu A$	-0.3		+0.8	V
V_{OL}	$I_{OH} = 2$ TTL Loads	+2.4		$+V_{CC}$	V
	$I_{OL} = 2$ TTL Loads	0.0		0.4	V
Data Clock					
Data I/O				8	MHz
SETUP Code I/O ⁽⁹⁾				4	MHz
Data Format					
Straight Binary	Unipolar or Bipolar Range		20		Bits
Two's Complement	Unipolar or Bipolar Range		21		Bits

SPECIFICATIONS (CONT)

ELECTRICAL

All specifications with unipolar current input range, $T_{INT} = 1\text{ms}$, correlated double sampling enabled, System Clock = 2MHz, $V_{REF} = -2.5\text{V}$, $T_A = +25^\circ\text{C}$ and $V_S = \pm 5\text{VDC}$, unless otherwise noted.

PARAMETER	CONDITIONS	DDC101			UNITS
		MIN	TYP	MAX	
POWER SUPPLY REQUIREMENTS					
Operation ⁽⁵⁾		± 4.75	± 5	± 5.25	VDC
Quiescent Current, Positive Supply	$V_{S+} = +5\text{VDC}$, $V_{DD+} = +5\text{VDC}$		15.6	19.5	mA
Analog, V_{S+}			8.9		mA
Digital, V_{DD+}			6.7		mA
Quiescent Current, Negative Supply	$V_{S-} = -5\text{VDC}$		18.0	22.5	mA
Operating Power			170		mW
TEMPERATURE RANGE					
Operating		-40		+85	$^\circ\text{C}$
Storage		-60		+100	$^\circ\text{C}$

NOTES: (1) Input = low level (less than 1% of Full Scale); Full Scale $I_{IN} = 500\text{nA}$; $T_{INT} = 1\text{ms}$; Unipolar Input Range; Acquisition Time = 16 clock cycles, Oversampling = 128. (2) Voltage input is converted through user provided input resistor, R_{IN} . (3) FSR is Full Scale Range. (4) Gain Drift does not include the drift of the external reference. (5) V_{DD+} must be less than or equal to V_{S+} . See Section 7 for recommended connections. (6) Straight Binary output code has slightly different Charge Range. See Section 6. (8) Input offset voltage is nulled by autozero circuitry and causes no output error. See Section 6 (Internal Error Correction). (9) This is the maximum clock frequency at which SETUP codes can be written to and read from the DDC101. (10) For other input current and voltage configurations, see Discussion of Specifications and Detailed Theory of Operation sections. (11) A best-fit straight line method is used to determine linearity. Two different best-fit straight lines are used for the two unipolar integral linearity specifications. Acquisition Time = 16 clock cycles, Oversampling = 128.

PACKAGE/ORDERING INFORMATION

PRODUCT	PACKAGE	PACKAGE DRAWING NUMBER ⁽¹⁾	THERMAL RESISTANCE (θ_{JA}) ($^\circ\text{C}/\text{W}$)
DDC101U	24-Lead SOIC	239	100

NOTE: (1) For detailed drawing and dimension table, please see end of data sheet, or Appendix C of Burr-Brown IC Data Book.

ABSOLUTE MAXIMUM RATINGS

Analog Inputs	
Input Current	100mA, momentary
Input Current	10mA, continuous
Input Voltage	$V_{S+} + 0.5\text{V}$ to $V_{S-} - 0.5\text{V}$
Power Supply	
V_{S+}	+ 7V
V_{S-}	-7V
V_{DD+}	must be $\leq V_{S+}$
Maximum Junction Temperature	+165 $^\circ\text{C}$

ELECTROSTATIC DISCHARGE SENSITIVITY

This integrated circuit can be damaged by ESD. Burr-Brown recommends that all integrated circuits be handled with appropriate precautions. Failure to observe proper handling and installation procedures can cause damage.

ESD damage can range from subtle performance degradation to complete device failure. Precision integrated circuits may be more susceptible to damage because very small parametric changes could cause the device not to meet published specifications.

The information provided herein is believed to be reliable; however, BURR-BROWN assumes no responsibility for inaccuracies or omissions. BURR-BROWN assumes no responsibility for the use of this information, and all use of such information shall be entirely at the user's own risk. Prices and specifications are subject to change without notice. No patent rights or licenses to any of the circuits described herein are implied or granted to any third party. BURR-BROWN does not authorize or warrant any BURR-BROWN product for use in life support devices and/or systems.

PIN CONFIGURATION

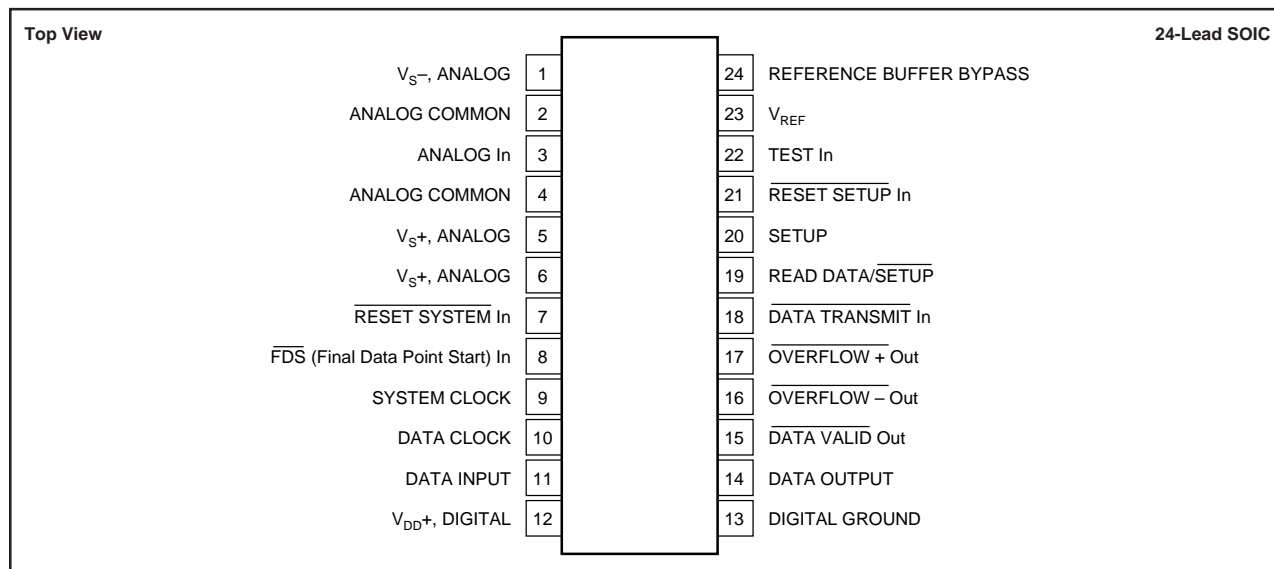

SECTION 3 PIN DESCRIPTIONS

PIN NUMBER	NAME	DESCRIPTION
1	V_{S-} , ANALOG	Negative analog power supply voltage, -5VDC.
2	ANALOG COMMON	Analog ground point.
3	ANALOG INPUT	Input for low level current signal. Photosensor can be directly connected to this input. With a resistor in series, DDC101 will convert a voltage input.
4	ANALOG COMMON	Analog ground point.
5	V_{S+} , ANALOG	Positive analog power supply voltage, +5VDC. Hardwire to pin 6.
6	V_{S+} , ANALOG	Positive analog power supply voltage, +5VDC. Hardwire to pin 5.
7	RESET SYSTEM In	This input resets DDC101, but does not reset the SETUP register. The DDC101 system is reset when this pin is active; reset action is removed when the pin is inactive.
8	\overline{FDS} In	This is Final Data point Start input. This input is the basic user control of the integration and conversion timing. When it becomes active, the DDC101 starts collection of the M, final data point samples. The beginning of the next integration time is exactly M system clock periods after the Final Data point Start command when operating in the continuous mode.
9	SYSTEM CLOCK	This clock input sets the basic sampling rate of the DDC101. The DDC101 is specified with a clock speed of 2MHz. The clock speed can be 0.5MHz to 2.0MHz.
10	DATA CLOCK	This clock input controls the data transfer rate for the serial DATA INPUT and DATA OUTPUT ports. The DATA CLOCK is independent of the SYSTEM CLOCK. This allows the DATA CLOCK to be operated at higher or lower speeds than the SYSTEM CLOCK. For best noise performance, data should not be transmitted and the DATA CLOCK should not be active during the initial and final data point collection. If data is being transmitted during the initial and final data point collection periods, the DATA CLOCK should be synchronized to the SYSTEM CLOCK, to minimize added noise. DATA CLOCK can be connected to SYSTEM CLOCK, so that the same clock is used for both; however, for best noise performance, the DATA CLOCK input should be active only when data is transmitted.
11	DATA INPUT	This input can be used to "daisy chain" the output of several DDC101s together to minimize wiring. The output register of the DDC101 acts as a shift register to pass through the output of previously connected DDC101 units. In this way, multiple DDC101 units can convert simultaneously then sequence the data out serially on the same data line with one common control line and one common data line for all DDC101 units.
12	V_{DD+} , DIGITAL	Digital power supply, +5VDC. V_{DD+} must be less than or equal to V_{S+} .
13	DIGITAL GROUND	Digital ground point.
14	DATA OUTPUT	This output provides serial digital data clocked out at user controlled DATA CLOCK rate. Output data format is a 21-bit Binary Two's Complement word or a 20-bit Straight Binary word. The data word is transmitted MSB first. When DATA TRANSMIT is not active DATA OUTPUT tri-states.
15	DATA VALID	This output is activated when conversion is complete and remains active until the DATA TRANSMIT input is activated.
16	OVERFLOW-	The OVERFLOW output signals each provide an open collector output so that the overflow outputs from several DDC101s can easily be connected (wire ORed) together to a common pull-up resistor. They are activated when the input is beyond the acceptable range during conversion. Specifically, they are activated when the internal D/A converter input or digital filter exceeds full scale. They are Cleared at the end of conversion 1/2 clock cycle after DATA VALID high. DATA VALID can be used to capture OVERFLOW data into an external register.
17	OVERFLOW+	

PIN DESCRIPTIONS (CONT)

PIN NUMBER	NAME	DESCRIPTION
18	DATA TRANSMIT In	This input controls the transmission of data from the serial I/O register of the DDC101. It can be activated anytime after DATA VALID out becomes active. It must remain active until all data has been collected from the serial I/O register(s) of all DDC101s in the data path.
19	READ DATA/ SETUP In	This input can be used to read back the current SETUP data. When this input is held high, the output from DATA OUTPUT is the data collected by the DDC101. When this input is pulled low, an internal shift register is loaded with the current SETUP data on the rising edge of DATA CLOCK. This SETUP data shift register is logically connected between DATA INPUT and DATA OUTPUT pins and can be read in the same way that the data output is read. SETUP data read back does not invalidate data already stored in the DDC101's serial I/O register or data being collected by the DDC101, although digital noise concerns should be considered as discussed in DATA CLOCK.
20	SETUP In	This input pin controls the DDC101 SETUP. A 12-bit digital word transmitted into this pin controls Acquisition Time, K, Oversampling, M, Multiple Integrations, L, Input Range and Output Data Format. The DDC101 reads the SETUP code at this pin after the RESET SETUP input transitions from active to inactive. The SETUP code is read into the SETUP register on the 12 positive data clock transitions following that transition.
21	RESET SETUP	Resets SETUP register only, does not reset balance of DDC101. The DDC101 reads SETUP input data after this input transitions from active (reset) to inactive.
22	TEST In	This is a digital input that controls the connection of an internal DC current source to the DDC101's input. TEST In exercises the DDC101 and is intended to test for functionality only. The typical test input current is 100nA ±20nA. The quiescent current of the DDC101 increases by approximately 1mA when TEST In is active. When TEST is HIGH, the internal current source is ON and current is flowing into the DDC101 input. When TEST is LOW, the current source is disconnected from the input.
23	V _{REF}	An external -2.5V reference must be connected to the REFERENCE In pin. Use of an external reference allows multiple DDC101s to use the same system reference for optimum channel matching. The external reference should be filtered to minimize noise contribution (see Figure 24).
24	REFERENCE	An external capacitor of 10µF should be connected to this node to provide proper operation of the internal BUFFER BYPASS D/A converter. The REFERENCE In pin is connected to an internal reference buffer amplifier. The internal reference buffer drives the internal CDAC. This buffer output is not intended for external use.

SECTION 4 TIMING CHARACTERISTICS

All specifications with Unipolar input range, T_{INT} = 1ms, Current Input, Correlated Double Sampling enabled, Sys Clock = 2MHz, V_{REF} = -2.5V, T_A = +25°C and V_S = ±5VDC, unless otherwise noted.

SYMBOL	DESCRIPTION	MIN	TYP	MAX	UNITS
t ₁	FDS Setup	30			ns
t ₂	FDS width, Continuous Conversion	50		(M-1) Clocks+t ₁ +100ns	ns
t ₃	FDS width, Asynchronous Conversion	M Clocks+t ₁			ns
t ₄	FDS HIGH to start of next integration, Asynchronous Conversion		50		ns
t ₅	Setup time for RESET SETUP HIGH to DATA CLOCK HIGH	60			ns
t ₆	Setup time for Setup Codes data valid before rising edge of DATA Clock	30			ns
t ₇	Hold time for Setup Codes data valid after rising edge of DATA Clock	30			ns
t ₈	Propagation delay from rising edge of SYSTEM CLOCK to DATA VALID LOW		50		ns
t ₉	Propagation delay from DATA TRANSMIT LOW to DATA VALID HIGH		35		ns
t ₁₀	Setup time for DATA CLOCK LOW to DATA TRANSMIT LOW	30			ns
t ₁₁	Propagation delay from DATA TRANSMIT LOW to valid data out		30		ns
t ₁₂	Hold time that Data output is valid after falling edge of DATA CLOCK	10			ns
t ₁₃	Propagation delay from DATA TRANSMIT HIGH to Data Output tri-stated			40	ns
t ₁₄	Propagation delay from falling edge of SYSTEM CLOCK to OVERFLOW+ and OVERFLOW-cleared	25			ns
t ₁₅	SYSTEM CLOCK pulse width HIGH	240			ns
t ₁₆	SYSTEM CLOCK pulse width LOW	240			ns
t ₁₇	DATA VALID LOW to DATA TRANSMIT LOW, Single DDC101	30		(LxN-21) Clocks	ns

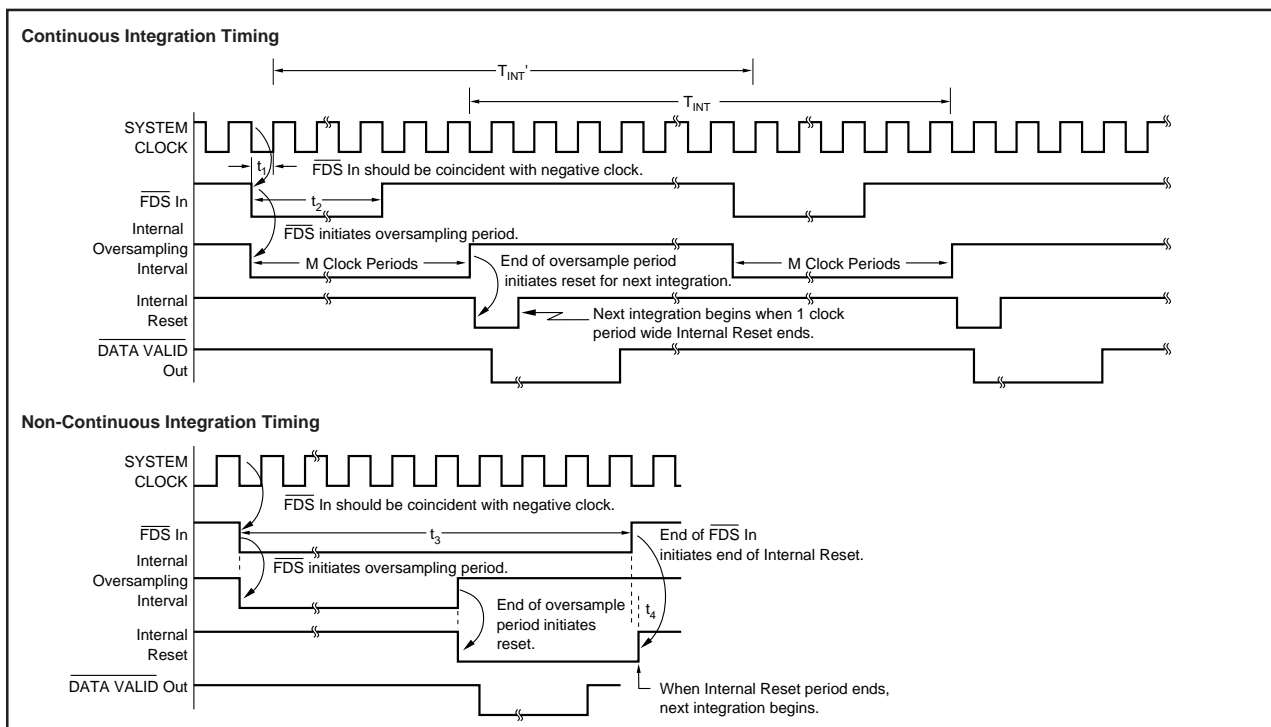

FIGURE 4. Conversion Timing Diagrams.

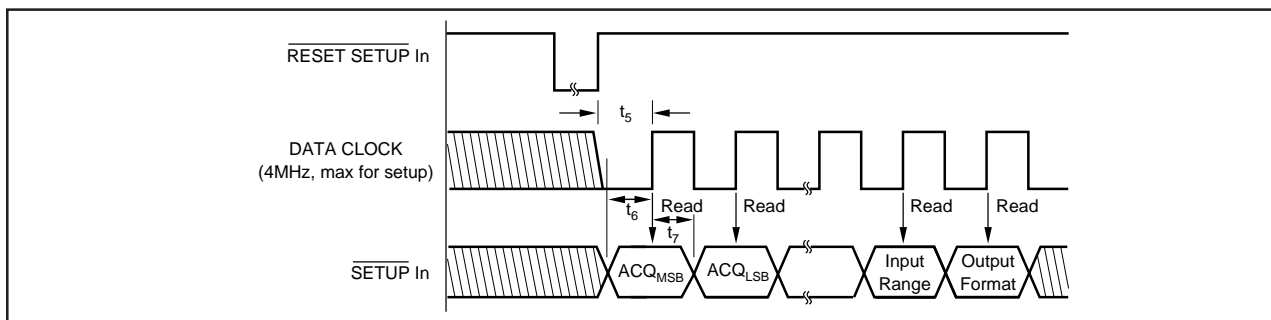

FIGURE 5. Input/Output Timing Diagram—SETUP Timing Diagram.

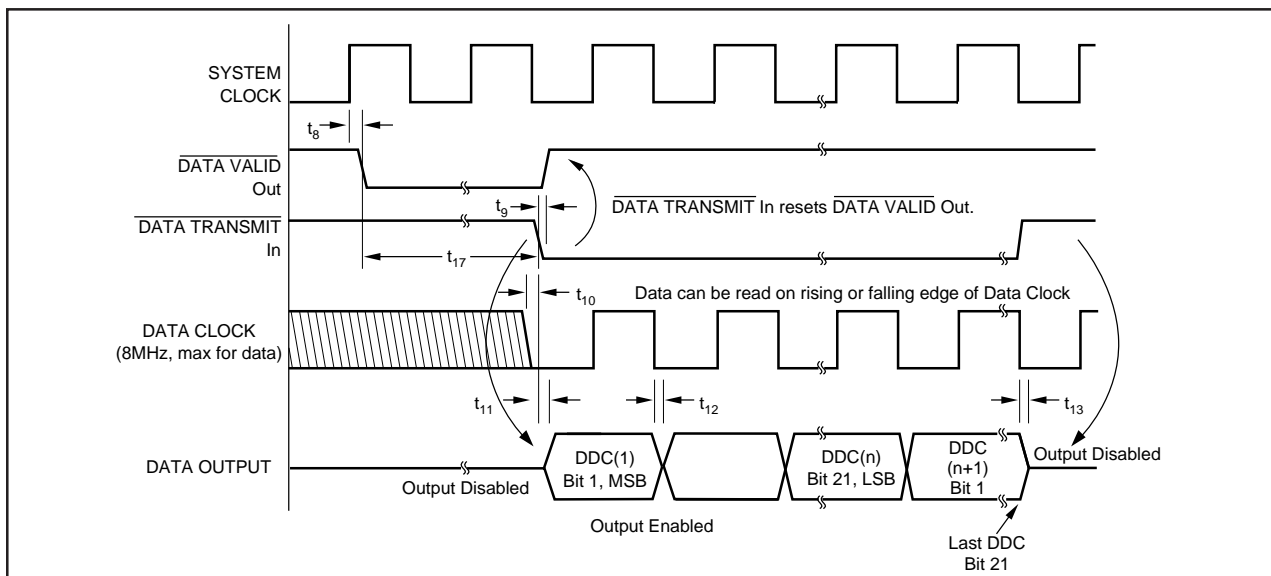

FIGURE 6. DATA TRANSMIT Timing Diagram.

TIMING DIAGRAMS (CONT)

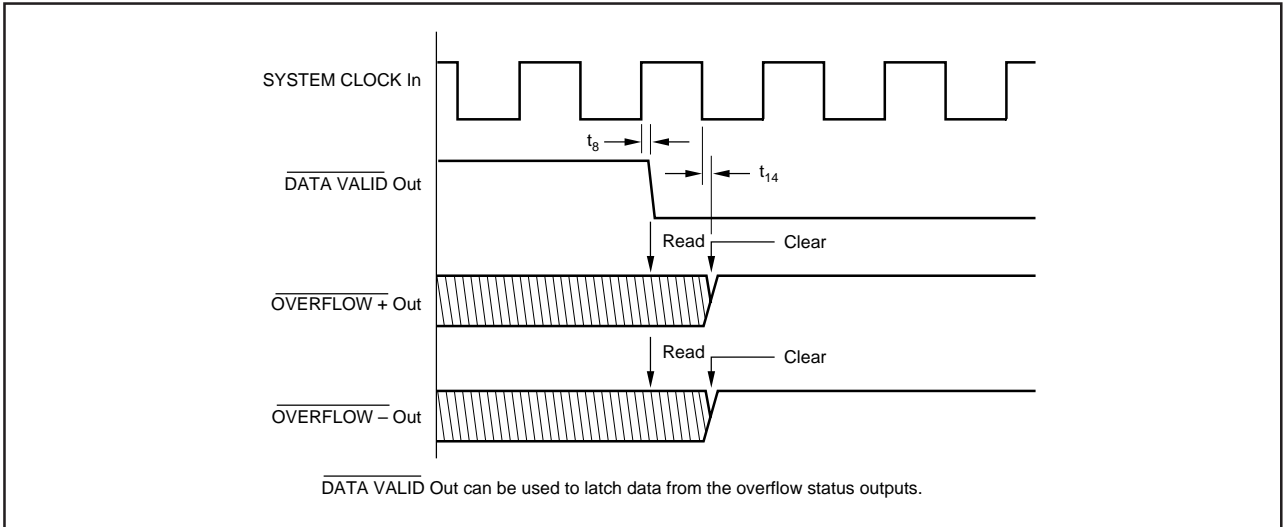

FIGURE 7. $\overline{\text{OVERFLOW}}$ Out Monitoring Timing Diagram.

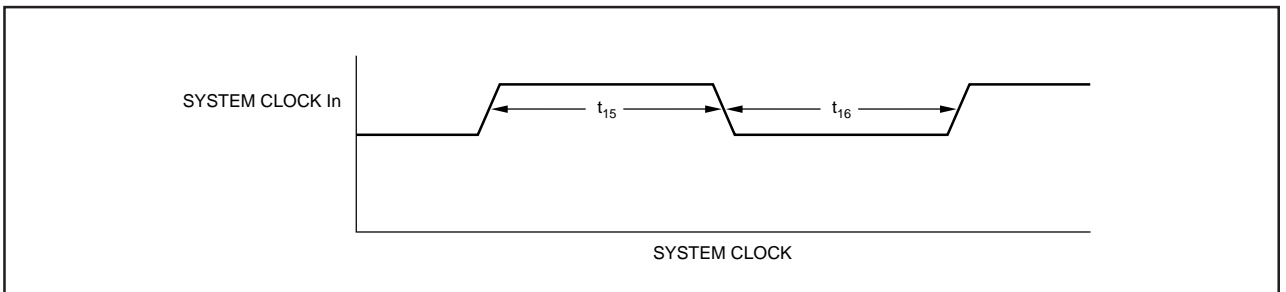
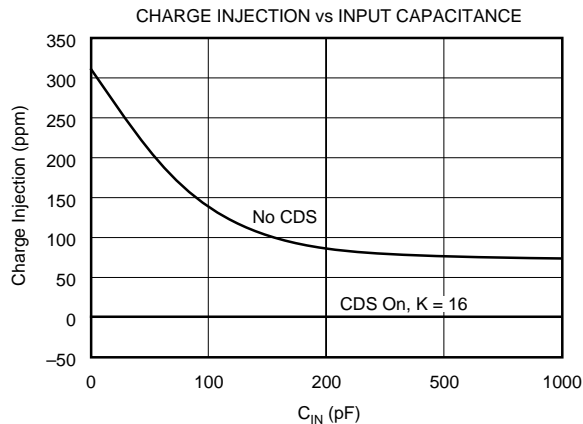
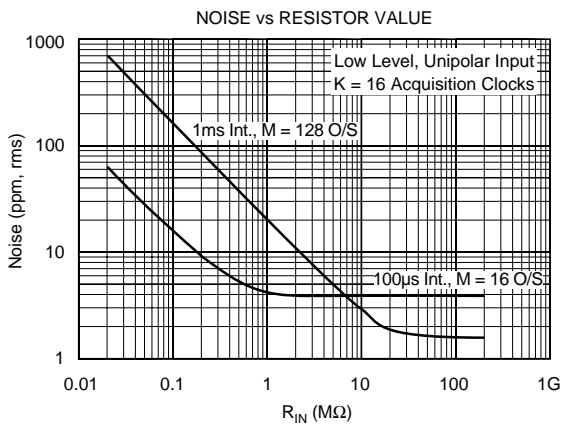
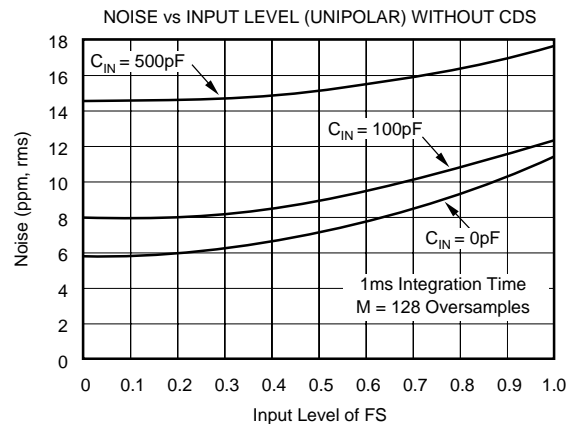
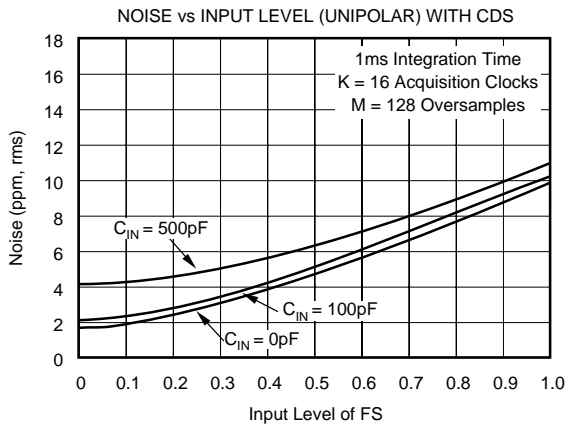
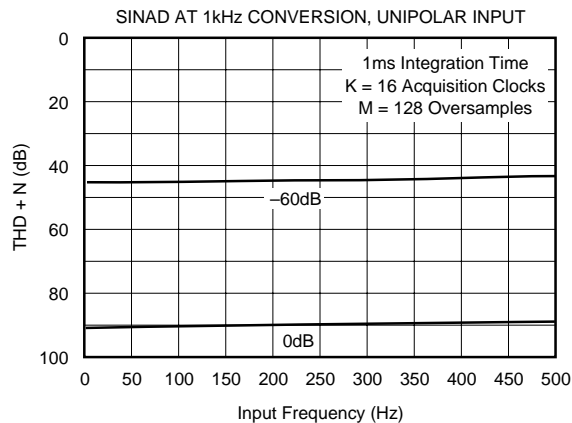
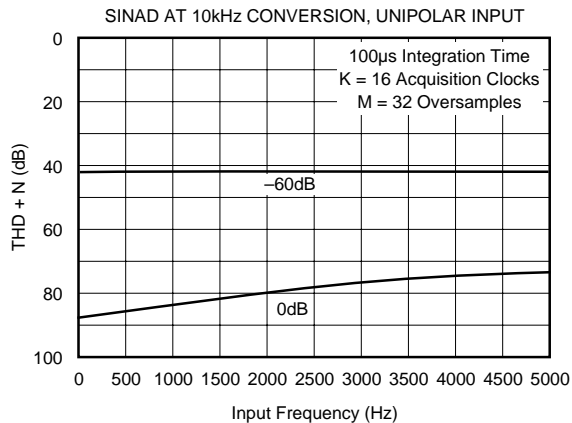

FIGURE 8. System Clock Timing.

TYPICAL PERFORMANCE CURVES

ELECTRICAL

System Clock = 2MHz, $V_S = \pm 5VDC$, $V_{REF} = -2.5V$, $L = 1$ Integration/Conversion, and $T_A = +25^\circ C$, unless otherwise noted.



TYPICAL PERFORMANCE CURVES (CONT)

ELECTRICAL

System Clock = 2MHz, $V_S = \pm 5\text{VDC}$, $V_{REF} = -2.5\text{V}$, $L = 1$ Integration/Conversion, and $T_A = +25^\circ\text{C}$, unless otherwise noted.

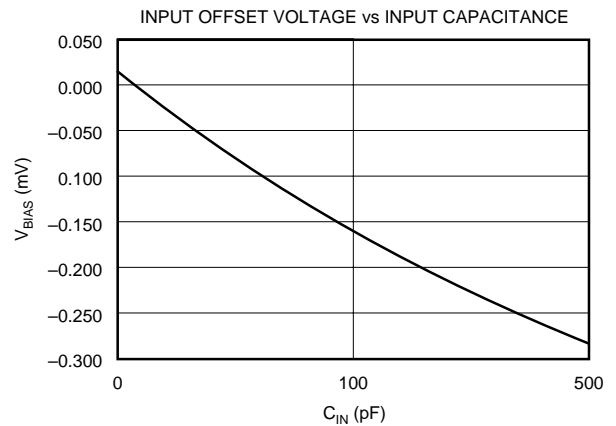
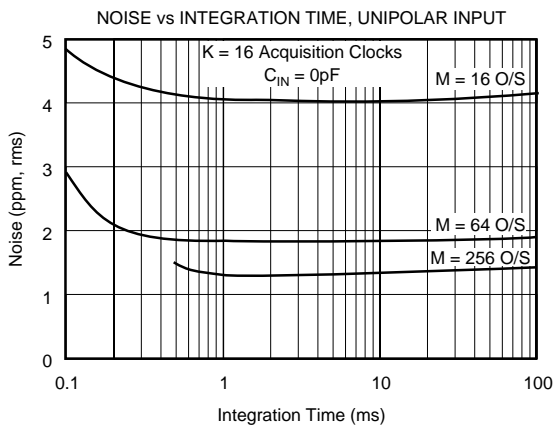
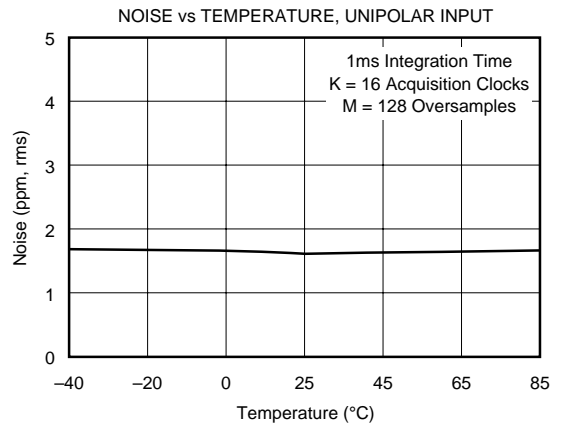
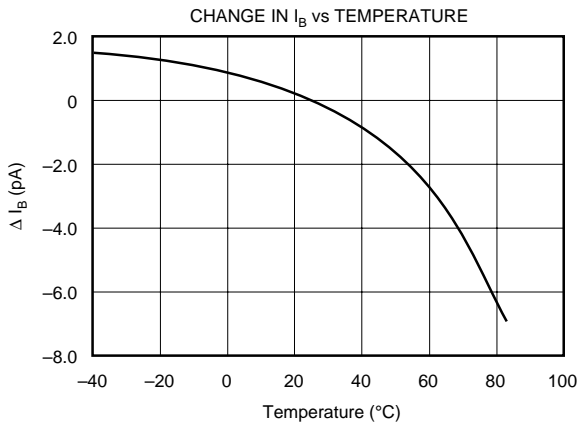
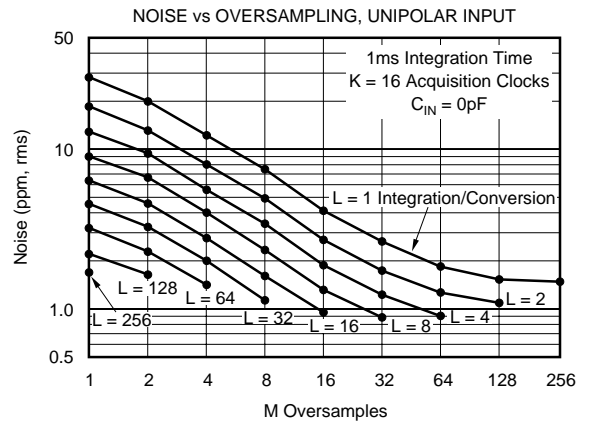
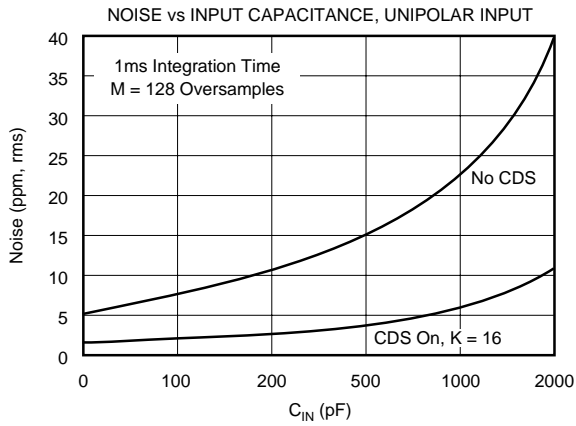

TYPICAL PERFORMANCE CURVES (CONT)

ELECTRICAL

System Clock = 2MHz, $V_S = \pm 5VDC$, $V_{REF} = -2.5V$, $L = 1$ Integration/Conversion, and $T_A = +25^\circ C$, unless otherwise noted.

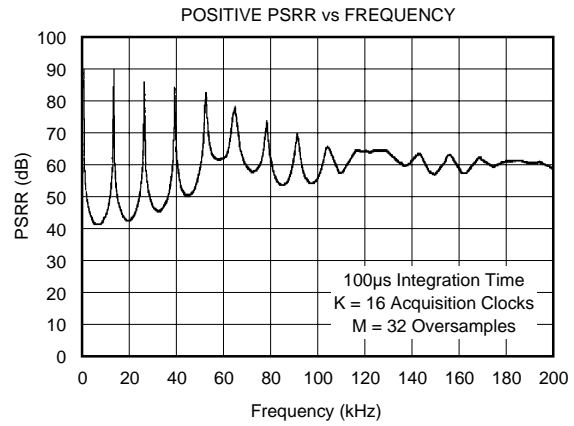
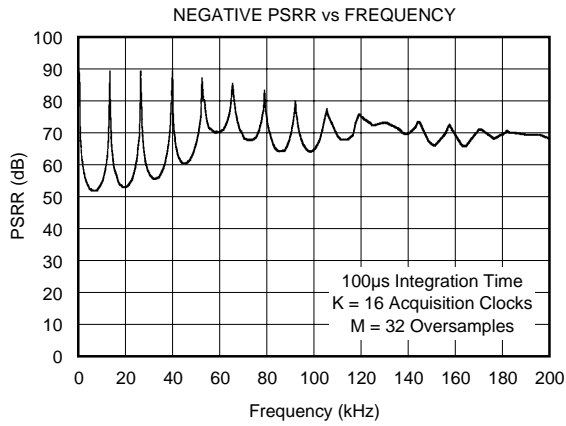
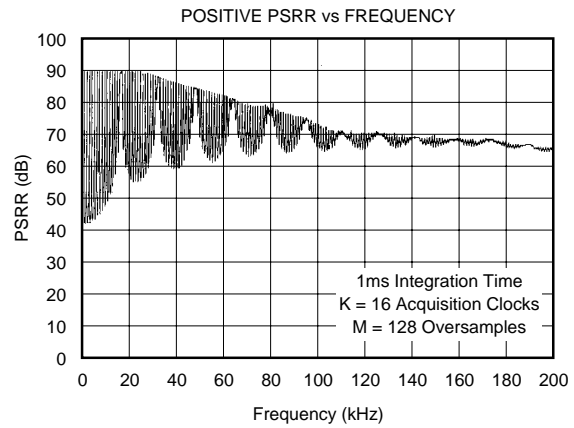
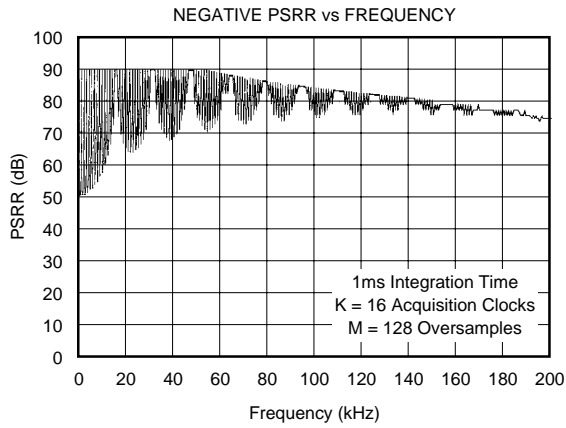

SECTION 5

DISCUSSION OF SPECIFICATIONS

INPUT

The DDC101 is a charge digitizing A/D converter. Low level current output sources, such as a photosensors, can be directly connected to its input. The input signal can also be a voltage connected through a user selected resistor.

CHARGE INPUT

The maximum charge that can be captured in one integration by the DDC101 is 500pC. In the unipolar input range mode, the maximum positive charge that can be collected in one integration is 500pC. The DDC101 has a small negative range in the unipolar mode of -1.95pC . This small negative underrange is included to allow for a small amount of leakage current from the user's PC board and sensor. In the bipolar input range, the maximum positive charge that can be collected is $+250\text{pC}$. The maximum negative charge that can be collected is -251.95pC .

In addition to the normal mode of one integration per conversion, DDC101 can be configured by the user for 1 to 256 integrations per conversion. When the multiple integrations per conversion mode is chosen, the DDC101 DSP circuitry internally averages multiple integration cycles to provide one conversion result. This result has lower noise because it is the average of multiple integrations. In this mode, the maximum total charge that can be captured by the DDC101 in 256 integrations is 128,000pC.

TEST CURRENT INPUT

An internal DC test current can be connected under user control to the DDC101's input. The test current is nominally 100nA and will be summed with any applied external input signal. It is derived by a resistive network from the positive power supply. The test current is intended to test for functionality only. The TEST IN pin of the DDC101 controls the current. When TEST is HIGH, the internal current source is ON and current is flowing into the DDC101 input. When TEST is LOW, the current source is disconnected from the input. With TEST active, positive power supply current increases by approximately 1mA.

FULL SCALE RANGE

The full scale range (FSR), which is referenced in the specification table, is the difference between the positive full scale charge and the negative full scale charge for the DDC101 in one integration cycle. Specifications such as noise and linearity, which are specified in percent or ppm of FSR, are referring to a value of 500pC for both unipolar and bipolar input ranges.

The full scale input current for a given integration time will result in a full scale input charge. As an example for unipolar

input range, an input current of $0.5\mu\text{A}$ integrated for 1ms will result in the full scale charge of 500pC. For voltage inputs, the input resistor is chosen to achieve the proper full scale input current. As an example, for a 5V full scale input, a $10\text{M}\Omega$ input resistor is selected to achieve a full scale input current of $0.5\mu\text{A}$ (1ms integration time).

Noise of 1.6ppm of FSR is equal to $1.6\text{ppm} \times 500\text{pC} = 0.8\text{fC}$ or $1.6\text{ppm} \times 0.5\mu\text{A} = 0.8\text{pA}$ or $1.6\text{ppm} \times 5\text{V} = 8\mu\text{V}$. Thus, in this instance, noise is 1.6pA or $8\mu\text{V}$.

For the unipolar input range, the following table shows the full scale input current required for different integration times to collect 500pC of charge and the equivalent current values for 2 and 5ppm of FSR.

T_{INT}	I_{FS}	2ppm	5ppm
50ms	10nA	0.02pA	0.5pA
5ms	100nA	0.2pA	1pA
1ms	500nA	1pA	2.5pA
500 μs	1 μA	2pA	5pA
100 μs	5 μA	10pA	25pA

TABLE I. Integration Time (T_{INT}) and Full Scale Current (I_{FS}) for Full Scale 500pC Integration.

CURRENT INPUT

The maximum average input current that can be captured by the DDC101 is $\pm 7.8\mu\text{A}$. This current will result in an integration time of 64 μs for unipolar input range and 32 μs for bipolar input range. For longer integration times, the average input current must be less.

The maximum input current is limited by the slew and update rate of the internal tracking logic and CDAC. The largest input current that the DDC101 can accurately track is $7.8\mu\text{A}$. Input currents larger than $7.8\mu\text{A}$ and high speed current input pulses can be accurately captured and digitized by the DDC101 with an external input or sensor capacitance on the DDC101 input. The average current during a complete integration cycle cannot exceed $7.8\mu\text{A}$. Likewise, the total charge input must not exceed 500pC unipolar, 250pC bipolar during the integration time.

An external user provided input capacitance, C_{S} , as shown in Figure 9a, will capture the input signal charge if the input current limit is temporarily exceeded during the integration cycle. The DDC101 will then transfer the charge completely to C_{INT} based upon conservation of charge. An additional

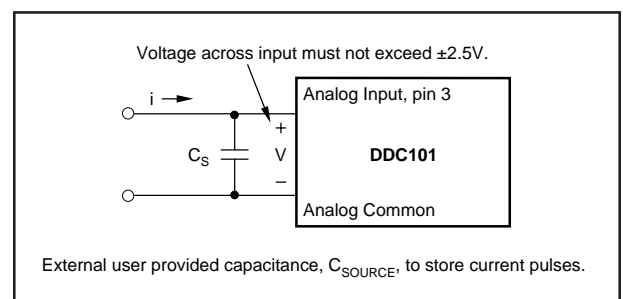

FIGURE 9a. Current Pulse Input Capture.

constraint is, the voltage that appears at the DDC101 input, must not exceed 2.5V. If this voltage is exceeded, charge may be lost and the integration result may be invalid. The input voltage can be calculated:

$$i(t) = C_S \frac{dv}{dt}$$

or

$$V = \frac{1}{C_S} \int i(t) dt$$

therefore,

$$V = i \frac{t}{C_S}$$

As an example, with a user supplied input capacitance of 100pF, a current pulse of 100μA for 2μs could be stored without exceeding 2.5V applied to the input:

$$V = (100\mu A) \cdot \frac{2\mu s}{100pF} = 2V.$$

The current pulse must occur completely during part of one DDC101 integration time, and the DDC101 must still have time to discharge the input capacitance to ground at a maximum rate of 7.8μA before the DDC101 is triggered (through the FDS input) to end the integration. In addition, the total charge integrated must be 500pC or less for the unipolar range. A current pulse of 100μA for 2μs creates 200pC of charge.

VOLTAGE INPUT SPECIFICATIONS

The DDC101 is a charge digitizing device. With a user provided input resistor, the DDC101 can digitize voltage inputs. All of the general charge/current input specifications apply to the voltage input situation. The specification table shows the typical noise of the DDC101 including the effects of a 20MΩ input resistor, R_{IN}.

The input of the DDC101 is a virtual ground. A voltage input causes a current, i, to flow into the input through R_{IN} as shown in Figure 9b. The maximum input current is determined by the integration time selected. Table II shows the

maximum input voltage based upon several selections of input current and input resistor for unipolar input range. The accuracy of the input resistor will add directly to the DC Gain Error of the DDC101; the drift of the input resistor will add directly to the Gain Drift of the DDC101.

Note that the DDC101 output noise decreases as R_{IN} increases. This is because the DDC101 noise gain decreases and the input resistance current noise decreases as R_{IN} increases. This effect is shown in the “Noise vs Resistor Value” typical performance curve.

INTEGRATION TIME	INPUT RESISTOR, R _{IN}		
	1ms	500μs	100μs
Full Scale Input Current	0.5μA	1μA	5μA
Full Scale Voltage			
50mV	100kΩ	50kΩ	10kΩ
500mV	1MΩ	500kΩ	100kΩ
5V	10MΩ	5MΩ	1MΩ
50V	100MΩ	50MΩ	10MΩ

TABLE II. Example of Input Resistor Values Unipolar Input Range.

UNIPOLAR LINEARITY ERRORS

Due to innovative design techniques, the absolute level of linearity error of the DDC101 improves as the input signal level decreases when used in the unipolar input mode. Therefore, in unipolar input mode, the integral linearity of the DDC101 is specified as a small base error plus a percentage of reading error or as a percentage of full scale range. A best-fit straight line method is used to determine integral linearity. Two different best-fit straight lines are used for the two unipolar integral linearity specifications. For bipolar input mode, linearity is specified only as a percentage of full scale range.

To illustrate the improvement in unipolar mode linearity error, Figure 10 shows the maximum unipolar integral linearity error (ILE) of the DDC101 as a function of the input signal level. The maximum integral linearity error is ±0.0244% of reading ±2.5ppm (ILE max for unipolar input of -1.95 to 0 pc is ±0.0244% of reading ±3.0ppm of FSR). Thus, the maximum ILE for an input level of 1% of FSR is 0.0005%FSR.

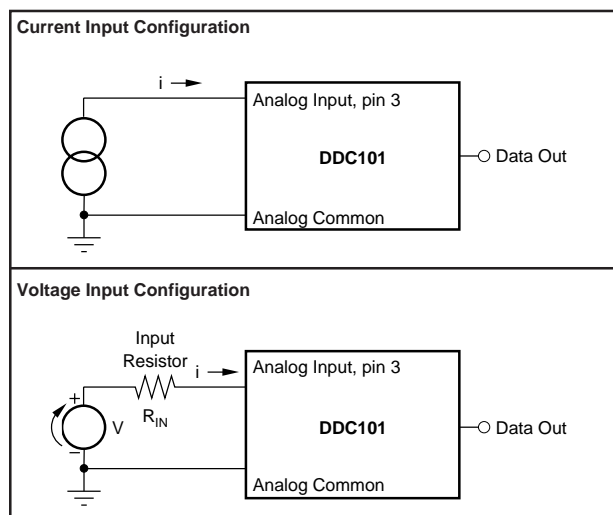

FIGURE 9b. DDC101 Input Configurations.

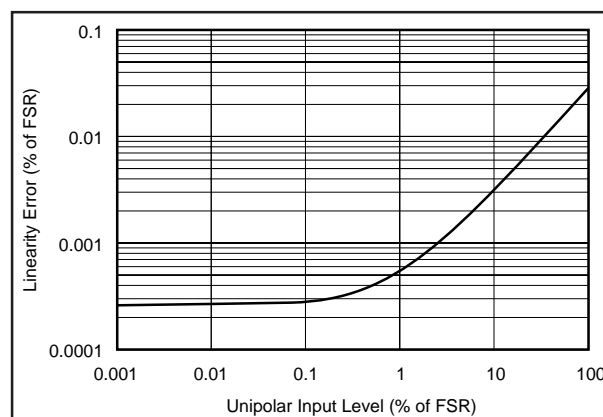

FIGURE 10. Maximum Unipolar Integral Linearity Error Relative to Full-Scale, Converted From % of Reading Specification.

NOISE

The noise of the DDC101 improves as the input signal level decreases, thus very low level signals can be resolved. Noise is shown in the specification table for low level inputs. For unipolar input range, the DDC101 noise at low level inputs is dominated by comparator noise gained to the output; at full scale inputs, the noise is dominated by D/A converter noise. The noise at low level inputs is a function of input capacitance; the noise at full scale is relatively independent of input capacitance. For bipolar input operation, the noise is dominated by D/A converter noise and is higher than the full scale unipolar noise.

BIPOLAR INPUT ACCURACY

Linearity—As a bipolar input device, the linearity of the DDC101 is specified as a percentage of full scale range that does not improve with lower input signal levels. Performance is generally limited by the linearity of the unit when operated in the bipolar input mode.

Noise—In general, noise is not as important as linearity when determining total error. The output noise of the DDC101 in the bipolar mode peaks at midscale (zero input signal level). Output noise is lower for inputs above and below zero.

RESET CHARGE ERROR

The reset charge error (typically less than 250fC) is an offset error that could result from offset voltage, charge injection and kT/C errors. The DDC101 eliminates the effects of reset charge errors with correlated double sampling.

DC BIAS VOLTAGE

The DDC101 generates a small bias voltage (typically 500 μ V) at the input. This voltage is impressed on any sensor that is connected to the input. The DC bias voltage is the actual virtual ground voltage of the DDC101. The DDC101 input comparator circuitry includes an autozero circuit which eliminates this offset internally so that it does not produce an output error.

GAIN SENSITIVITY TO V_{REF}

The DDC101 gain is dependent upon the external reference voltage, V_{REF} . A change in the value of V_{REF} will be seen as a directly proportional change in the gain of the DDC101.

FREQUENCY RESPONSE

The DDC101 is a sampling system whose transfer function has three separate frequency components. These components are multiplied together to make the total frequency characteristic of the DDC101. The three components are:

1. Basic Integration

This is the characteristic $\sin(x)/x$ response of the basic integration function. This response is controlled by the integration time of the DDC101.

2. Oversampling

This is the low pass filter characteristic of the digital filter's oversampling. This response reduces the broadband noise in the input signal and the DDC101. Broadband noise decreases as the number of oversamples increases.

3. Multiple Integrations

This is the low pass filter characteristic that results when the digital filter is used to average multiple integrations.

This will determine the primary response of the DDC101 if two or more integrations are internally averaged.

See Section 6 for more details.

SECTION 6 DETAILED THEORY OF OPERATION

INTEGRATION CYCLE

An integration cycle, as illustrated in Figure 11, includes the Acquisition Time, Initial Data Point Sampling, Tracking Interval, and Final Data Point Sampling. The Acquisition Time is K clock periods. The first clock cycle of the Acquisition Time is used to reset the integrating capacitor, C_{INT} , to zero from the previous integration. The balance of the Acquisition Time insures that the DDC101 system is accurately tracking the input signal prior to initial data point acquisition. Close-ups of the Reset and Acquisition time are shown in Figures 12 and 13.

The Initial Data Point is then sampled M times. The Integration cycle time consists primarily of the Tracking Interval during which time the DDC101 "tracks" the integration of the input signal. The Tracking Interval is followed by the measurement of the Final Data Point with the same user selected number of samples, M. M and K are user selectable. The entire integration cycle consists of N clock periods as controlled by the user.

The DDC101 operates in continuous and non-continuous integration modes. In the continuous mode, one integration follows another with no delay from the end of one integration to the beginning of the next conversion. In the non-continuous mode, each new integration is started separately under user control.

The Final Data point Start (FDS) input is the primary user control of the integration cycle. The FDS input controls the end of one integration cycle and the start of the next integration cycle in both the continuous and non-continuous integration modes. Measurement of the M final data point samples begins when the FDS input is activated.

CONTINUOUS INTEGRATION MODE

In the continuous integration mode, the "Final Data Point Start" command (using the FDS pin) initiates the measurement of the M final data point samples. The next integration cycle begins immediately after the final data point sampling

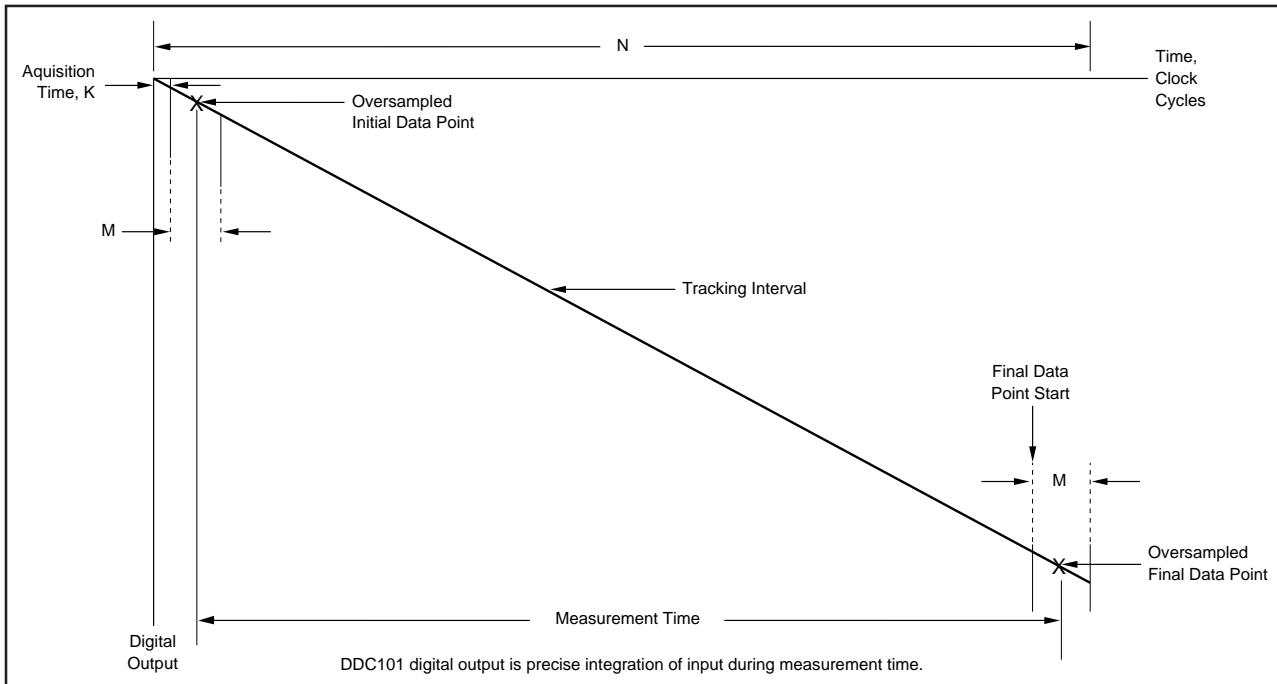

FIGURE 11. Equivalent Integrator Output for Single Integration.

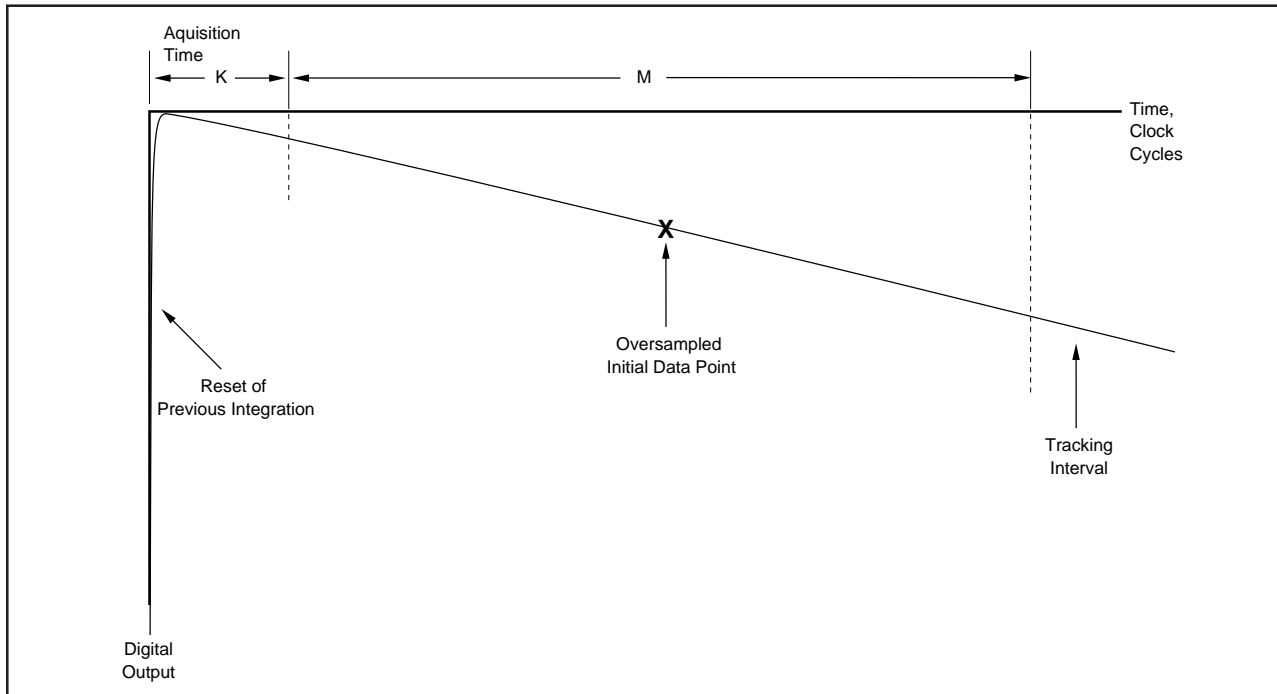

FIGURE 12. Close-up of Initial Oversampled Data Point for DDC101.

has been completed; this occurs M clock periods after the FDS transition to "ON". Acquisition, Initial Data Point and Tracking for the next integration follow automatically. The DDC101 continues in the Tracking mode until the next FDS command initiates the measurement of the M final data point samples. An FDS command is needed for each integration cycle. In the continuous integration mode, the FDS pulse width must be less than M clock periods. If the FDS pulse

is held low past this time of M clock periods, the DDC101 will reset as for non-continuous mode (see also Figure 4).

In the continuous mode of operation, the tracking logic of the DDC101 "remembers" the integration rate of the previous integration and begins the next integration at the rate of the previous integration. This allows faster acquisition of the signal for the next integration.

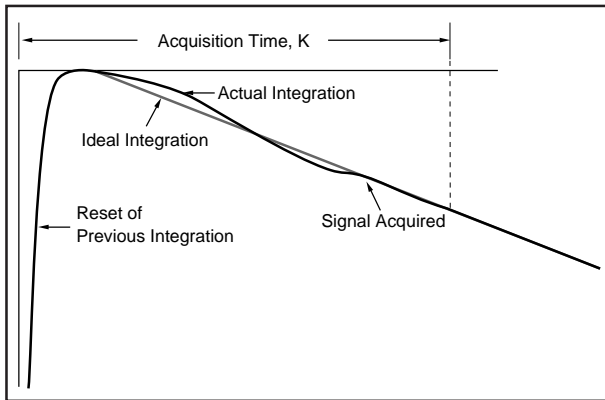

FIGURE 13. Close-up of Reset and Acquisition Time for DDC101.

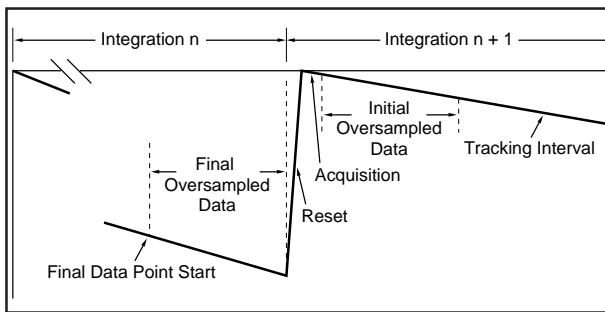

FIGURE 14. Close-up of End of One Integration Cycle and Beginning of Next.

NON-CONTINUOUS INTEGRATION MODE

For the non-continuous integration mode, FDS controls the start of the M final data point samples and the end of integration as discussed above. In this mode, however, FDS is also used to control the start of a new integration cycle asynchronously with the end of the previous integration. When FDS transitions to “ON”, the collection of the M final data point samples begins. At the end of each integration, the DDC101 automatically resets the integration capacitance. If FDS remains “ON” past the end of integration, the DDC101 will stay in the integration reset state until FDS transitions to “OFF”. Holding FDS “ON” past the end of integration will also reset the DDC101’s tracking logic to zero integration rate.

In non-continuous integration mode, the initial data point measurement may be less accurate since the DDC101’s internal tracking logic is reset at the beginning of the integration and tracking may not be accurate for the initial data point measurement. In this situation, Correlated Double Sampling (CDS) operation may not be advantageous.

INTERNAL ERROR CORRECTION

The DDC101 uses CDS techniques to gain optimum performance. CDS removes internal DDC101 errors which occur for a given integration cycle such as, charge injection, kT/C , and DDC101 offset errors. Correlated Double Sampling is user selectable. It is recommended for most continuous measurement applications.

Correlated Double Sampling is implemented in the DDC101 by subtracting the Initial Data Point from the Final Data Point. Thus, the error correction is updated automatically for each integration. When operating in the unipolar input range, CDS functions with either output data format—straight binary or binary two’s complement. When operating in the bipolar input range, CDS functions with binary two’s complement output data format only.

The errors that CDS removes are charge injection, kT/C and DDC101 input voltage offset. These errors are very difficult to eliminate in equivalent analog circuits. Charge injection errors result from charge that is transferred through the reset switch into the integration capacitor. kT/C errors are switching errors due to the noise of the resistance of the reset switch. DDC101 voltage offset errors are due to input offset of the input comparator. Both initial offset and offset drift with time and temperature are corrected since the correction is performed each integration cycle.

SINGLE CYCLE INTEGRATION

The DDC101 acquires charge (q) by integrating input current (i) for a specific time (T). That is,

$$q = \int_0^T i \, dt$$

The DDC101 acquires up to 500pC of full scale charge per integration cycle in the unipolar input range, and approximately ± 250 pC of full scale charge in the bipolar input range. Therefore, for the DDC101, maximum values can be calculated.

Unipolar Input Range	Bipolar Input Range
$500\text{pC} = I_{\text{FS}} \times T_{\text{INT}}$	$\pm 250\text{pC} = \pm I_{\text{FS}} \times T_{\text{INT}}$

Where I_{FS} is the full scale input current and T_{INT} is the integration time of the DDC101. Examples of I_{FS} and T_{INT} that equal 500pC and ± 250 pC are shown in the following tables.

The maximum average input current that the DDC101 can integrate is 7.8 μ A. This results in a minimum integration time of 64 μ s for unipolar inputs and 32 μ s for bipolar inputs. Further flexibility is possible with multiple integration cycles per conversion as described in the following text.

INPUT RANGE

Unipolar Input Range

For the unipolar input range, the range of charge for each integration cycle is from positive full scale of +500pC to a slightly negative charge of $-1/256$ (approximately -0.4%) of the positive full scale charge. This is +500pC to -1.95 pC. The negative charge measurement capability allows for low level PC board parasitic leakages.

Bipolar Input Range

For the bipolar input range, the range of charge for each integration cycle is from positive full scale of +250pC to negative full scale of -251.95 pC.

I_{FS}	T_{INT}
1nA	500ms
10nA	50ms
100nA	5ms
1 μ A	500 μ s
5 μ A	100 μ s
7.8 μ A	64 μ s

TABLE III. Input Current vs Integration Time Examples for Maximum Charge. Unipolar input range maximum charge = 500pC.

$\pm I_{FS}$	T_{INT}
1nA	250ms
10nA	25ms
100nA	2.5ms
1 μ A	250 μ s
2.5 μ A	100 μ s
7.8 μ A	32 μ s

TABLE IV. Input Current vs Integration Time Examples for Maximum Charge. Bipolar input range maximum charge = ± 250 pC.

MULTIPLE INTEGRATIONS PER CONVERSION CYCLE

If more than 500pC, unipolar (or ± 250 pC, bipolar) of charge must be integrated in one conversion cycle, the DDC101 can be user programmed for multiple integrations per conversion cycle. This feature can be used to provide for longer conversion periods for a specific input current other than shown in the previous table. The integration cycles forming a conversion cycle may be continuous or non-continuous. The number of integrations per conversion cycle, L, can be 1, 2, 4, 8, 16, 32, 64, 128, or 256. The multiple integrations are automatically averaged in the DDC101 so that one conversion result is output per total conversion cycle. Note that each integration requires individual control by the FDS signal. For example, if L = 4, then four FDS signals per conversion are required.

FINAL DATA POINT CONFIGURATION LIMITS

In each conversion cycle, the maximum number of final data points which can be collected is 256. This means that at the extremes, the DDC101 can be setup to perform one integration cycle with 256 oversamples, or the DDC101 can be setup to perform 256 integration cycles with one sample per integration cycle. The total number of integrations, L, multiplied by the number of samples per final data point, must be 256 or less. As an example, if 16 integration cycles, L, are used, the number of samples per final data point must be 16 or less.

NOTE: When CDS is used, the initial data points impose no additional conversion sampling limitations.

FREQUENCY RESPONSE

The DDC101 charge digitizing A/D Converter is a sampled system whose frequency response has three separate components. These components are multiplied together to make the total frequency characteristic of the DDC101. The three frequency response components are shown below. Each

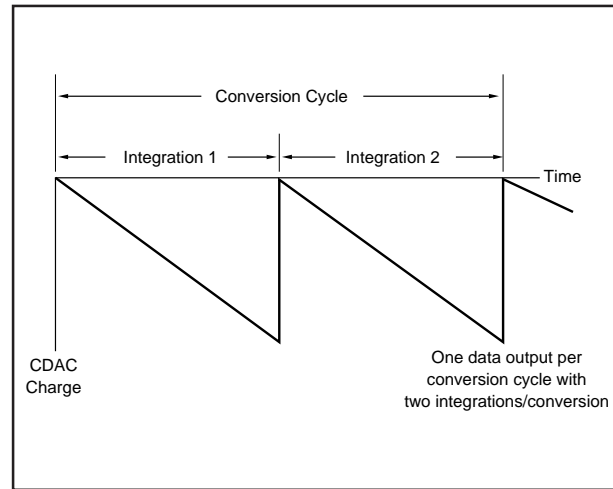

FIGURE 15. Conversion Cycle with Two Integrations.

INTEGRATIONS PER CONVERSION	I_{FS}	CONVERSION TIME	MAX CHARGE/ CONVERSION
L = 1	10nA	50ms	500pC
L = 2	10nA	100ms	1000pC
L = 4	10nA	200ms	2000pC
L = 8	10nA	400ms	4000pC
L = 16	10nA	800ms	8000pC
L = 32	10nA	1.6s	16000pC
L = 64	10nA	3.2s	32000pC
L = 128	10nA	6.4s	64000pC
L = 256	10nA	12.8s	128000pC

TABLE V. Integrations/Conversion vs Conversion Time. Example for multiple integrations with unipolar input range.

individual component has a sinc ($\sin x/x$) frequency response function.

1. Basic Integration

This is the characteristic $\sin(x)/x$ response of the basic integration function. This response is controlled by the measurement time of the DDC101, T_{MEAS} ; see Figure 16.

2. Oversampling

This is the low pass filter characteristic of the digital filter's oversampling. This response reduces the broadband noise in the input signal of the DDC101. Broadband noise decreases as the number of oversamples increases. This response is controlled by the number of oversamples, M; see Figure 17.

3. Multiple Integrations

This is the low pass filter characteristic that results when the digital filter is used to average multiple integrations. This will determine the primary response of the DDC101 if two or more integrations are internally averaged. This response is controlled by the total conversion time of the DDC101; see Figure 18.

Input frequencies are multiplied by the DDC101 frequency response. The Nyquist frequency is $f_{CONV}/2$, where f_{CONV} is the DDC101 conversion rate. The highest frequency that can be reconstructed from the output data is $f_{CONV}/2$. Input frequencies above Nyquist are multiplied by the DDC101 frequency response and are then aliased into DC to $f_{CONV}/2$.

Basic Integration Frequency Response

The $\sin(x)/x$ basic integration characteristic is controlled by the digital filter's measurement time (T_{MEAS}). The measurement frequency, f_{MEAS} is $1/T_{MEAS}$. The input frequency response of the DDC101 is down -3dB at $f_{MEAS}/2.26$ with a null at f_{MEAS} . Subsequent nulls are at harmonics $2f_{MEAS}$, $3f_{MEAS}$, $4f_{MEAS}$, etc. as shown in the frequency response curve below. This characteristic is often used to eliminate known interference by setting f_{MEAS} or a harmonic to exactly the frequency of the interference. Table VI illustrates the frequency characteristics of the DDC101 integration function for various measurement times. As an example, for $N = 2272$, $K = 16$, and $M = 256$: $T_{MEAS} = (N-M-K)/f_{CLK} = (2272-256-16)/2\text{MHz} = 1\text{ms}$ and $f_{MEAS} = 1\text{kHz}$. $T_{INT} = 2272/2\text{MHz} = 1.14\text{ms}$; $f_{CONV} = 1/T_{INT} = 880\text{Hz}$.

MEASUREMENT TIME	-3dB FREQUENCY	f_{MEAS}
100 μs	4.42kHz	10kHz
1ms	442Hz	1kHz
10ms	44.2Hz	100Hz
16.66ms	26.5Hz	60Hz
20ms	22.1Hz	50Hz

TABLE VI. Basic Integration Frequency Response Examples.

Oversampling Frequency Response

The M oversamples of the initial and the final data points create an oversampling $\sin(x)/x$ type of low pass filter response. The oversampling function reduces broadband noise of the input signal and the DDC101. Broadband noise is reduced approximately in proportion to the square root of the number of oversamples, M . As an example, a conversion with 128 oversamples will have approximately $1/2$ the noise of a conversion with 32 oversamples ($\sqrt{32/128} = \sqrt{1/4} = 1/2$). The oversampling low pass filter response creates a null

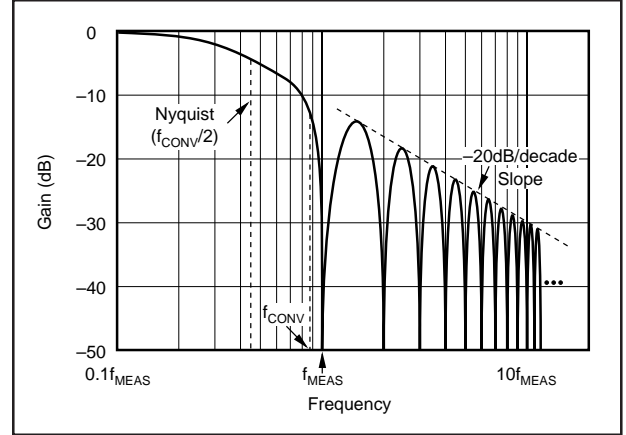

FIGURE 16. Basic Integration Frequency Response.

at $f_{OS} = 1/T_{OS}$. The oversample time, T_{OS} , is M/f_{CLK} . For $M = 256$ and $f_{CLK} = 2\text{MHz}$, f_{OS} is approximately 7.8kHz. Subsequent nulls are at harmonics $2f_{OS}$, $3f_{OS}$, $4f_{OS}$, etc. The -3dB point is at $f_{OS}/2.26$. Table VII illustrates the DDC101 oversampling frequency characteristics with approximate values for f_{OS} and the -3dB frequency. An oversampling frequency response graph is shown below in Figure 17. This figure shows the frequency response for $M = 256$ oversamples with an f_{CLK} of 2MHz. The slope of the attenuation curve decreases at approximately 20dB/decade.

OVERSAMPLES (M)	-3dB FREQUENCY	f_{OS}
256	3.5kHz	7.8kHz
128	6.9kHz	15.6kHz
64	13.9kHz	31.2kHz
16	55kHz	125kHz

TABLE VII. Oversample Frequency Response Examples.

Normalized DDC101 Frequency Response

The normalized frequency response, $H(f)$, of the DDC101 that is applied to the input signal consists of the product of the three frequency response components:

$$H(f) = \underbrace{\frac{\sin(\pi f(N-M-K)/f_{CLK})}{\pi f(N-M-K)/f_{CLK}}}_{\text{Basic Integration}} \cdot \underbrace{\frac{\sin(\pi M/f_{CLK})}{M \sin(\pi f/f_{CLK})}}_{\text{Oversampling}} \cdot \underbrace{\frac{\sin(\pi L N/f_{CLK})}{L \sin(\pi N/f_{CLK})}}_{\text{Multiple Integrations}} \cdot \underbrace{e^{-j\pi f(LN-K-1)/f_{CLK}}}_{\text{Linear Phase}}$$

Where:

f is the signal frequency

f_{CLK} is the system clock frequency, typically 2MHz

N is the total number of clock periods in each integration time, $T_{INT} = N/f_{CLK}$, T_{INT} is the DDC101 CDAC's integration time

M is the number of oversamples in one oversampled data point

K is the number of clocks used in the acquisition time

$(N-M-K)/f_{CLK}$ is the digital filters measurement time, T_{MEAS} , ($T_{MEAS} = T_{INT} - (M+K)/f_{CLK}$)

M/f_{CLK} is the oversample time, T_{OS}

LN/f_{CLK} is the total conversion time for multiple integrations, T_{CONV}

The DDC101's transfer response has a linear phase characteristic as indicated by the exponential term.

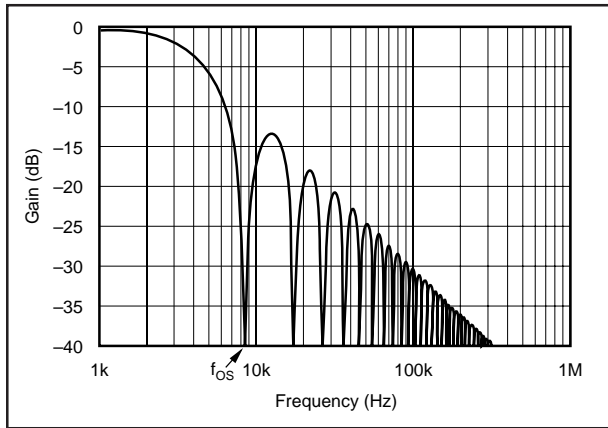

FIGURE 17. Oversampling Frequency Response for M = 256 ($f_{CLK} = 2\text{MHz}$).

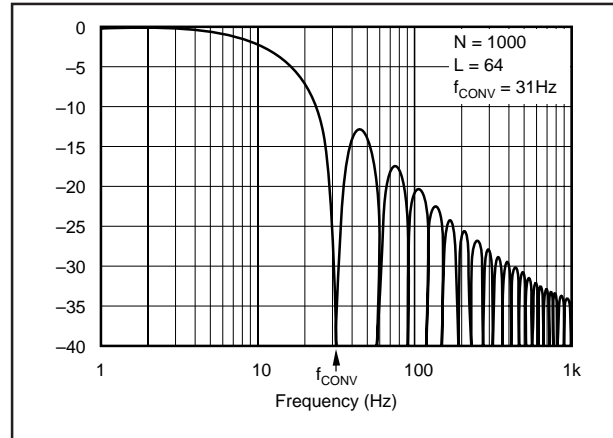

FIGURE 18. A Multiple Integration Frequency Response Example.

Multiple Integration Frequency Response

If the DDC101 is operated in the multiple integrations per conversion mode of operation, an additional $\sin(x)/x$ type low pass filter is created. The filter creates an initial null frequency at the conversion frequency, f_{CONV} of the DDC101 and at multiples of f_{CONV} . The -3dB point for this filter is also at $f_{CONV}/2.26$. The conversion time, T_{CONV} , is the sum of the integration times for multiple integrations that are averaged together by the DDC101. $T_{CONV} = LN/f_{CLK}$, $f_{CONV} = 1/T_{CONV}$. If multiple integrations per conversion are used, this filter will be the dominant low frequency filter of the DDC101. Table VIII shows examples of the conversion time and frequency for different parameter selections. Figure 18 shows an example of the frequency response due to Multiple Integrations. In the case of Figure 18, the integration time is $500\mu\text{s}$ ($N = 1000$ clock periods) and $L = 64$ integrations per conversion.

INTEGRATION TIME	L	CONVERSION TIME	-3dB FREQUENCY	f_{CONV}
1ms	2	2ms	221Hz	500Hz
1ms	8	8ms	55Hz	125Hz
1ms	16	16ms	27.5Hz	62.5Hz
1ms	64	64ms	6.9Hz	15.6Hz
1ms	256	256ms	1.73Hz	3.91Hz
10ms	2	20ms	22.1Hz	50.0Hz
10ms	8	80ms	5.5Hz	12.5Hz
10ms	16	160ms	2.75Hz	6.25Hz
10ms	64	640ms	0.69Hz	1.56Hz
10ms	256	2560ms	0.173Hz	0.39Hz

TABLE VIII. Multiple Integration Time Examples.

System Noise implications

The noise at the digital output of the DDC101 consists of system noise that is included in the analog input signal and noise from the DDC101.

DDC101 Noise—The noise of the DDC101 includes low frequency and broadband noise. The low frequency noise is reduced by the integrating function and the CDS function of the DDC101. This is reflected in the basic integration frequency response and in the multiple integration frequency response. The broadband electronic noise is reduced primarily by the oversampling function of the DDC101

Signal Noise—The noise of the input signal is filtered and reduced in a manner similar to the DDC101 noise reduction through the integrating and oversampling functions of the DDC101.

Figures 19 and 20 show the frequency response of the DDC101 for the product of the basic integration and oversampling frequency response for two different values of M. In both examples, the integration time is 1ms, the only difference is in the number of oversamples, M; for Figure 19, M = 256 oversamples was used; for Figure 20, M = 32 oversamples was used. The first null frequency is f_{MEAS} and subsequent nulls are at multiples of f_{MEAS} . The first example with the larger number of oversamples (M = 256) clearly reduces high frequency noise more than the second example with M = 32.

For M = 256, f_{OS} is 7.8kHz, f_{MEAS} is 1.16kHz, and the -3dB frequency is 507Hz. For M = 32, f_{OS} is 62.4kHz, f_{MEAS} is 1.02kHz and the -3dB frequency is 453Hz.

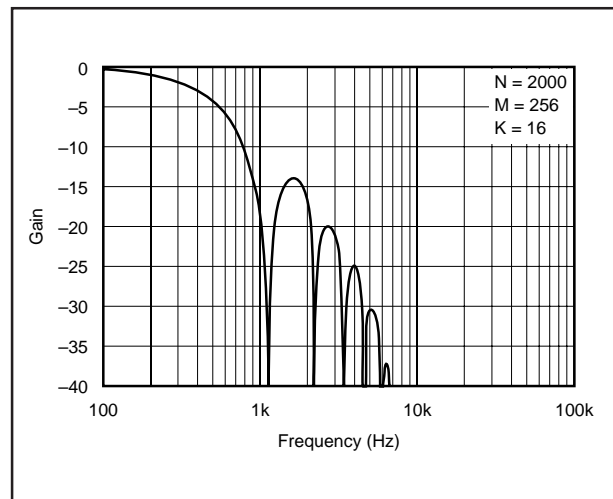

FIGURE 19. Product of Frequency Response of Basic Integration and Oversampling: 1ms Integration Time, 256 Oversamples.

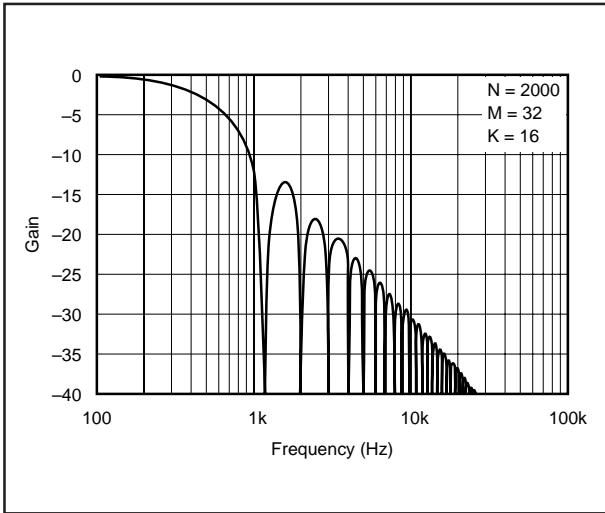

FIGURE 20. Product of Frequency Response of Basic Integration and Oversampling; 1ms Integration Time, 32 Oversamples.

Figure 21 shows the frequency response of the DDC101 and an ideal integrator with the same integration time. In this comparison, the DDC101 has greater bandwidth to the first null, but it also has greater out of band attenuation which reduces broadband noise significantly. If desired, the frequency response of the ideal integrator can be produced by passing the DDC101 output through an external digital filtering function which has the frequency response from DC to Nyquist of

$$\frac{\sin(\pi f T_{INT})}{\pi f T_{INT}} \cdot \frac{\pi f T_{MEAS}}{\sin(\pi f T_{MEAS})} \cdot \frac{M \sin(\pi f / f_{CLK})}{\sin(\pi f M / f_{CLK})}$$

This has the effect of further attenuating undesired signals (noise) outside the “passband”, further increasing the signal-to-noise ratio of the DDC101 and closely emulating the ideal integrator’s signal accumulation characteristics.

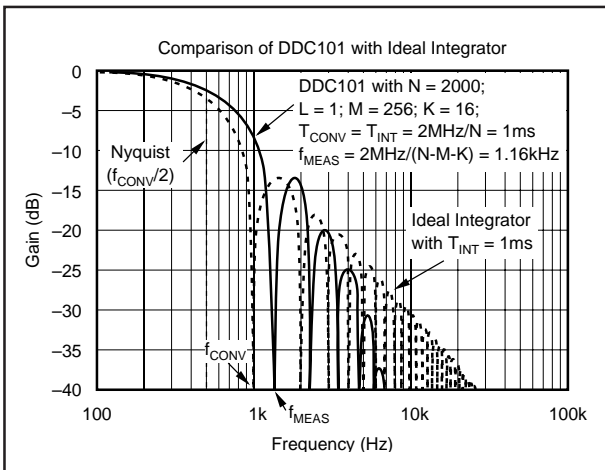

FIGURE 21. Comparison of DDC101 with Ideal Integrator.

SYSTEM SETUP

After power up, the Reset System and FDS signal inputs should be held low (active), while the SETUP register is loaded by the user. After the SETUP register is loaded, the Reset System input should transition to inactive while the FDS input remains active. The FDS should transition to inactive at the start of operation. Thereafter, Reset System should stay inactive and the FDS should be used to control each integration cycle.

SETUP INPUT

Software Control

Many of the options of the DDC101 are set through a serial bit stream transmitted by the user into the SETUP Input pin. The 12-bit word transmitted into the SETUP Input is used to set the following four options, in sequence:

1. Acquisition Time Control, K 2 bits
2. Oversampling Control
Samples/Integration, M 4 bits
3. Multiple Integration Control
Integrations/Conversion, L 4 bits
4. Unipolar or Bipolar Input Range 1 bit
5. Output Format 1 bit

Total for SETUP 12 bits

See Figure 5: SETUP Timing Diagram.

Acquisition Time Control, K

This signal sets the acquisition time (K clock periods) and controls the use of Correlated Double Sampling. The acquisition time occurs at the start of each new integration. The acquisition time control can be set to four options: “no CDS”, 1, 16 or 32 clock periods. For typical continuous integration applications, K = 16 is recommended. The acquisition time always begins with one clock period for reset. This reset clock period is followed by 0, 15 or 31 clock periods for signal acquisition. Correlated Double Sampling is activated if the initial acquisition time is set to 1, 16 or 32 clock periods. Correlated Double Sampling is disabled and the Initial Data Point is not acquired if “no CDS” is selected.

K	RESET CLOCKS	ACQUISITION CLOCKS	CDS
“No CDS”	1	0	Disabled
1	1	0	Enabled
16	1	15	Enabled
32	1	31	Enabled

TABLE IX. Acquisition Time Control, K.

When Correlated Double Sampling is activated, the DDC101 acquires the initial data point for error correction as part of each conversion. At the end of the conversion cycle, the initial data point is subtracted from the final data point. The errors that are corrected with CDS are charge injection, kT/C noise, and DDC101 voltage offset. When Correlated Double Sampling is deactivated, the initial data point is not taken.

When operating in the unipolar input range, CDS functions with either output data format—straight binary or binary two’s complement. When operating in the bipolar input range, CDS functions correctly only with binary two’s complement output data format.

Oversampling Control Samples/Integration, M

This control sets the number of samples, M, used by the DDC101 to oversample the initial and final data points. M can be set for these values: 1, 2, 4, 8, 16, 32, 64, 128, 256. Broadband noise in the conversion is reduced roughly in proportion to the square root of M. Therefore, a conversion with 128 oversamples will have 1/2 the broadband noise of a conversion with 32 oversamples. See the previous frequency response discussion.

Multiple Integration Control, L

This control sets the number of integrations per conversion cycle, L. It is used to reduce the data rate, increase the magnitude of the input signal range, and/or reduce the noise. The product of L and M must be 256 or less.

Output Format

Two output formats are available for either the unipolar or bipolar input ranges:

Binary Two’s Complement (BTC) and Straight Binary.

UNIPOLAR INPUT RANGE

For Binary Two’s Complement, output data format, the output word is a 21-bit Two’s Complement word. The first bit is the sign bit followed by the Most Significant Bit (MSB), etc. The output range is +100%FS to –0.4%FS, where FS is 500pC.

CODE	INPUT SIGNAL	
0 1111 1111 1111 1111 1111	+100%FS	+500pC
0 1111 1111 1111 1111 1110	+100%FS –1LSB	
0 0000 0000 0000 0000 0001	+1LSB	
0 0000 0000 0000 0000 0000	Zero	0pC
1 1111 1111 1111 1111 1111	–1LSB	
1 1111 1111 0000 0000 0000	–0.4%FS	–1.95pC

TABLE X. BTC Code Table—Unipolar Input Range.

For Straight Binary output data format, the output is a 20-bit straight binary word. The first bit is the Most Significant Bit (MSB), etc. The output range is +99.6%FS to –0.4%FS in which +99.6%FS represents positive full scale and –0.4%FS represents the minimum input.

CODE	INPUT SIGNAL	
1111 1111 1111 1111 1111	+99.6%FS	498.05pC
1111 1111 1111 1111 1110	+99.6%FS –1LSB	
0000 0001 0000 0000 0001	+1LSB	
0000 0001 0000 0000 0000	Zero	
0000 0000 0000 0000 0000	–0.4%FS	–1.95pC

TABLE XI. Straight Binary Code Table — Unipolar Input Range.

BIPOLAR INPUT RANGE

For Binary Two’s Complement, output data format, the output word is a 21-bit Two’s Complement word. The first bit is the sign bit followed by the Most Significant Bit (MSB), etc. The output range is +100%FS to –100.8%FS, where FS is 250pC. For the bipolar input range, the output code table changes with the use of Correlated Double Sampling (CDS). (There is no difference with or without CDS in the output code table when using the unipolar input range.)

CODE	INPUT SIGNAL	
0 1111 1111 1111 1111 1111	+100%FS	+250pC
0 1111 1111 1111 1111 1110	+100%FS –1LSB	
0 1000 0000 0000 0000 0001	+1LSB	
0 1000 0000 0000 0000 0000	Zero	0pC
0 0111 1111 1111 1111 1111	–1LSB	
0 0000 0000 0000 0000 0001	–100%FS + 1LSB	
0 0000 0000 0000 0000 0000	–100%FS	–250pC
1 1111 1111 0000 0000 0000	–100.8%FS	–251.95pC

TABLE XII. BTC Code Table — Bipolar Input Range without CDS.

CODE	INPUT SIGNAL	
0 0111 1111 1111 1111 1111	+100%FS	+250pC
0 0111 1111 1111 1111 1110	+100%FS – 1LSB	
0 0000 0000 0000 0000 0001	+1LSB	
0 0000 0000 0000 0000 0000	Zero	0pC
1 1111 1111 1111 1111 1111	–1LSB	
1 1000 0000 0000 0000 0001	–100%FS + 1LSB	
1 1000 0000 0000 0000 0000	–100%FS	–250pC
1 0111 1111 0000 0000 0000	–100.8%FS	–251.95pC

TABLE XIII. BTC Code Table — Bipolar Input Range with CDS.

For Straight Binary output data format with the bipolar input range, the output is a 20-bit straight binary word. The first bit is the Most Significant Bit (MSB), etc. The output range is +100%FS to –100%FS in which +100%FS represents positive full scale and –100%FS represents the negative full scale. *When using the straight binary output data format in bipolar input range, do not use CDS. This will cause a negative overflow to occur.*

CODE	INPUT SIGNAL	
1111 1111 1111 1111 1111	+100%FS	+250pC
1111 1111 1111 1111 1110	+100%FS – 1LSB	
1000 0000 0000 0000 0001	+1LSB	
1000 0000 0000 0000 0000	Zero	0pC
0111 1111 1111 1111 1111	–1LSB	
0000 0000 0000 0000 0000	–100%FS	–250pC

TABLE XIV. Straight Binary Code Table — Bipolar Input Range without CDS.

SETUP INPUT CODE

Acquisition Time Control—K - 2 bits

CODE	RESULT
00	1 Reset clock period, 0 clock period Acquisition Time, CDS disabled, no initial data point,
01	1 Reset clock period, 0 clock period Acquisition Time
10 ⁽¹⁾	1 Reset clock period, 15 clock period Acquisition Time
11	1 Reset clock period, 31 clock period Acquisition Time

NOTE: (1) Recommended for continuous integration mode.

Oversampling Control
Samples/Integration—M - 4 bits

CODE	SAMPLES PER INTEGRATION
0000	1
0001	2
0010	4
0011	8
0100	16
0101	32
0110	64
0111	128
1XXX	256

Multiple Integration Control
Integrations/Conversion—L - 4 bits

CODE	INTEGRATIONS PER CONVERSION
0000	1
0001	2
0010	4
0011	8
0100	16
0101	32
0110	64
0111	128
1XXX	256

Input Range - 1 bit

CODE	INPUT RANGE
0	Unipolar
1	Bipolar

Output Format - 1 bit

CODE	OUTPUT FORMAT
1	Binary Two's Complement
0	Straight Binary

SECTION 7
APPLICATIONS INFORMATION

BASIC PRINTED CIRCUIT BOARD LAYOUT

As with any precision circuit, careful printed circuit layout will ensure best performance. Make short, direct interconnections and avoid stray wiring capacitance—particularly at the analog input pin. Digital signals should be kept as far from the analog input signals as possible on the PC board.

Leakage currents between PC board traces can exceed the input bias current of the DDC101 if care is not taken. A circuit board “guard” pattern for the analog input pin and for the PC board trace that connects to the analog input pin is recommended. The guard pattern reduces leakage effects by surrounding the analog input pin and trace with a low impedance analog ground. Leakage currents from other portions of the circuit will flow harmlessly to the low impedance analog ground rather than into the analog input of the DDC101. Analog ground pins are placed on either side of the analog input pin in the DDC101 package to allow convenient layout of guard patterns. Figure 22 illustrates the use of guard patterns to protect the analog input.

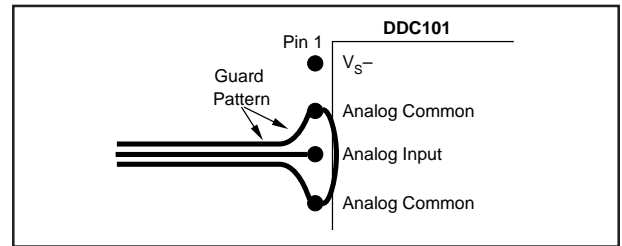

FIGURE 22. PC Board Layout Showing “Guard” Traces Surrounding Analog Input Pin and Traces.

Power Supplies

The $\pm 5\text{VDC}$ supplies of the DDC101 should be bypassed with $10\mu\text{F}$ solid tantalum capacitors and $0.1\mu\text{F}$ ceramic capacitors. The supplies should each have a $10\mu\text{F}$ solid tantalum capacitor at a central point on the PC board. Each of the DDC101 power supply lines (V_{S+} , V_{S-} , V_{DD+}) should have a separate $0.1\mu\text{F}$ ceramic capacitor placed as close to the DDC101 package as possible.

The digital power supply voltage, V_{DD+} must be equal to or less than the analog power supply voltage, V_{S+} . The analog power supply, V_{S+} , is connected to pins 5 and 6, these pins should be hardwired together on the printed circuit board at the pins for best performance.

V_{DD+} should be as quiet as possible with minimal noise coupling. It is particularly important to eliminate noise from V_{DD+} that is non-synchronous with DDC101 operation. Figure 23 illustrates two acceptable ways to supply V_{DD+} power to the DDC101. The first case shows two separate $+5\text{VDC}$ supplies for V_{DD+} and V_{S+} . The second case shows the V_{DD+} power supply derived from the V_{S+} supply as used on the DDC101 Evaluation Fixture Device Under Test (DUT) board.

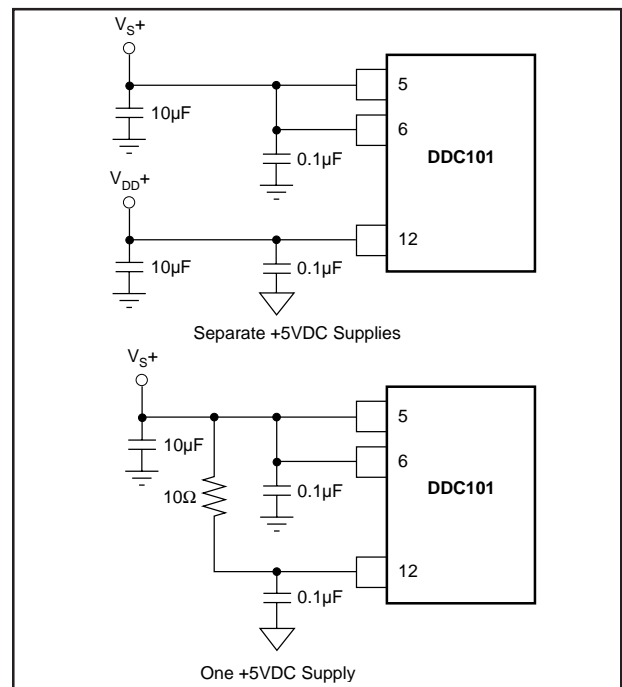

FIGURE 23. Positive Supply Connection Options.

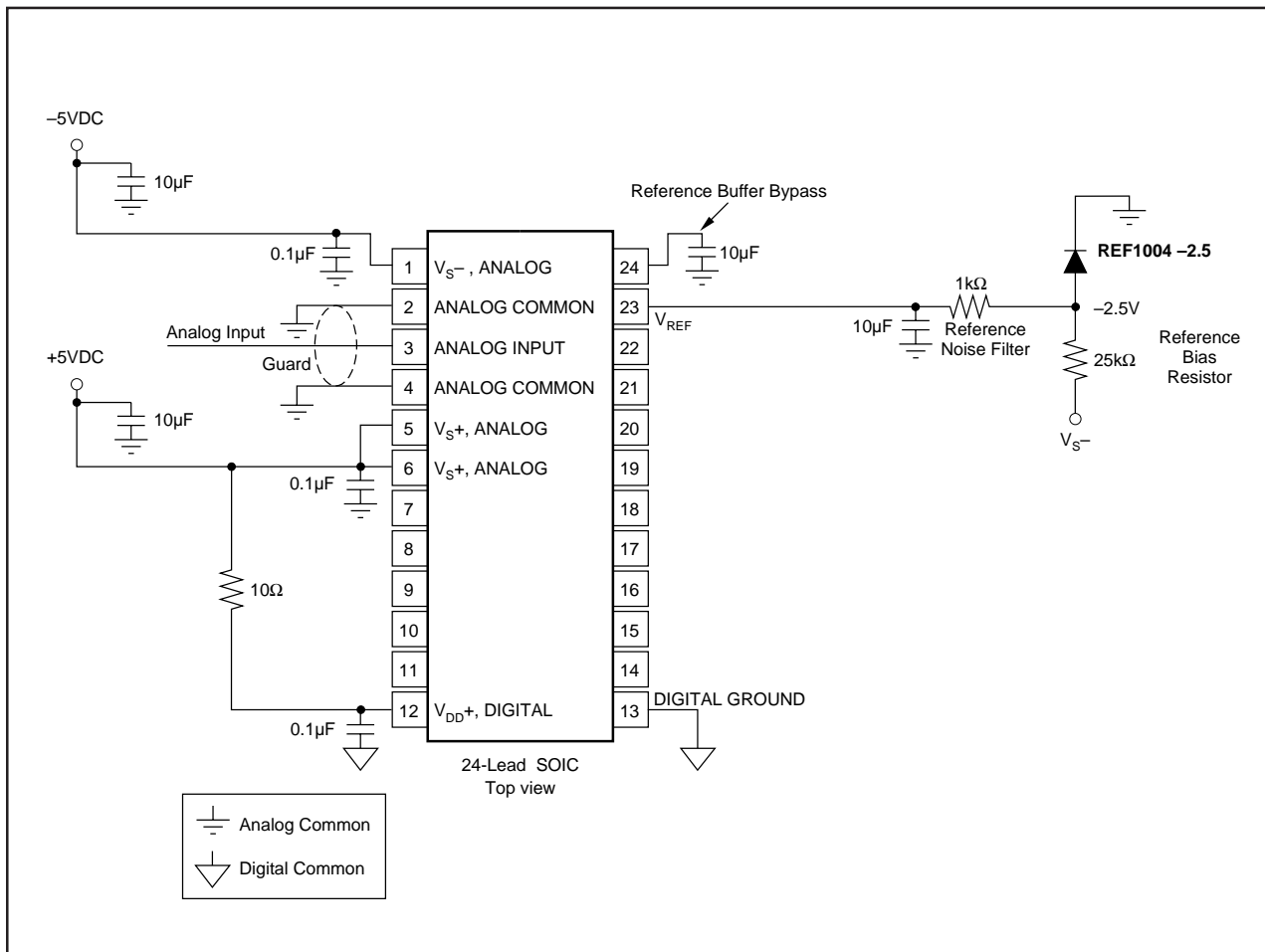

FIGURE 24. Example of Basic DDC101 Circuit Connections.

Reading Data Output

Data from the previous conversion can be read any time after the DATA VALID output is activated and before the end of the next conversion. Data is held in an internal serial shift register until the end of the next conversion. The data must be completely read before the end of the next conversion or it will be overwritten with new data.

Recommended Setup

The following Setup parameters are recommended, in general, for use with the DDC101 with integration times of 1ms or longer. Multiple integrations per conversion, where practical, will provide lowest noise as illustrated in the typical performance curves.

Measurement Time Calculation

FUNCTION	RECOMMENDED
Acquisition Clocks, K	16
Oversamples, M	128
CDS	Enabled

A Continuous Integration Cycle consists of the Acquisition Time, Initial Data Point Collection, Tracking Interval, and Final Data Point Collection. The user can select these functions as illustrated in Table XV.

The time between “Final Data point Start” commands is the Integration Time, T_{INT} . The Measurement Time, T_{MEAS} , is the Integration time reduced by the Acquisition Time and by the Oversampling Time, T_{OS} .

$$T_{MEAS} = T_{INT} - T_{ACQ} - T_{OS}$$

When CDS is used; T_{OS} , the oversampling time, is the time required to collect a data point (M clock periods). Each group of samples is averaged with the result at the midpoint of each sample group. Therefore, with CDS, $T_{OS} = M$ clock periods. This is shown in Figure 25.

Two calculations of the Measurement Time are shown

FUNCTION	CLOCK CYCLES	USER CONTROLLED
Acquisition Time, K	1, 16, 32	Yes
Initial Data Point Samples, $M^{(1)}$	1, 2, 4, 8, 16, 32, 64, 128, 256	Yes
Tracking Interval	Variable	Yes
Final Data Point Samples, $M^{(1)}$	1, 2, 4, 8, 16, 32, 64, 128, 256	Yes

NOTE: (1) Will be the same in CDS mode, initial Data Point Samples = 0 in non-CDS mode.

TABLE XV. Components of Integration Cycle.

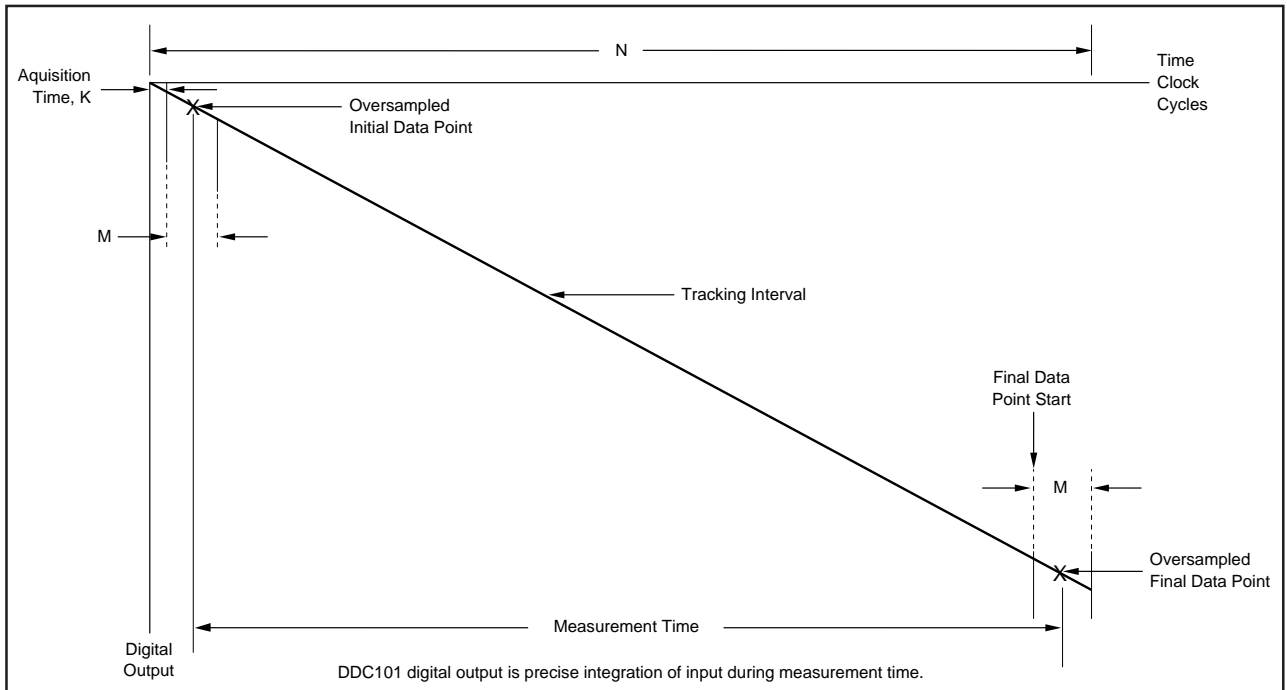

FIGURE 25. DDC101 Equivalent Integrator Output for Single Integration with CDS.

FUNCTION	USER SETTING (Clock Cycles)	TIME	MEASUREMENT (Calculated)
Integration Time (T_{INT})		1ms	
Acquisition Time K (T_{ACQ})	16	8 μ s	
Initial Data Point Samples, M	128	64 μ s	
Measurement Time			928 μ s
Final Data Point Samples, M	128	64 μ s	

TABLE XVI. Measurement Time with CDS.

below: one with Correlated Double Sampling (CDS) and the other without CDS. Each example assumes that the recommended system clock frequency of 2MHz is used and that the time between “Final Data point Start” commands, (the integration time, T_{INT}) is 1ms.

Example with CDS. The Measurement Time with CDS is calculated as the Integration Time (T_{INT}) of 1ms less T_{ACQ} and T_{OS} . T_{OS} , the oversampling time, is 1/2 of the Initial Data Point time plus 1/2 the Final Data Point time since each group of samples is averaged with the result at the midpoint of each sample group.

Therefore, the Measurement Time = 1ms – (8 + 32 + 32) μ s = 928 μ s.

Example without CDS. The Measurement Time without CDS is calculated as the Total Integration Time (T_{INT}) of 1ms less T_{ACQ} and T_{OS} . T_{OS} , the oversampling time, is 1/2 of the Final Data Point time since this group of samples is averaged with the result at the midpoint of the sample group.

Therefore, the Measurement Time = 1ms – (0.5 + 32) μ s = 967.5 μ s.

FUNCTION	USER SETTING (Clock Cycles)	TIME	MEASUREMENT (Calculated)
Integration Time (T_{INT})		1ms	
Acquisition Time, K (T_{ACQ}) “No CDS”	1	0.5 μ s	
Initial Data Point Samples	None	0 μ s	
Measurement Time			967.5 μ s
Final Data Point Samples, M	128	64 μ s	

TABLE XVII. Measurement Time without CDS.

Input Current Calculation

The following formula calculates the input current from the actual DDC output:

$$\text{With CDS: } i = \frac{500\text{pC} \cdot \left[\frac{\text{DDC output}}{2^{20}} \right]}{T_{MEAS}}$$

$$i = \frac{500\text{pC} \cdot \left[\frac{\text{DDC output}}{2^{20}} \right]}{T_{INT} - K \text{ clock periods} - M \text{ clock periods}}$$

$$\text{Without CDS: } i = \frac{500\text{pC} \cdot \left[\frac{\text{DDC output}}{2^{20}} \right]}{T_{MEAS}}$$

$$i = \frac{500\text{pC} \cdot \left[\frac{\text{DDC output}}{2^{20}} \right]}{T_{INT} - K \text{ clock periods} - M / 2 \text{ clock periods}}$$

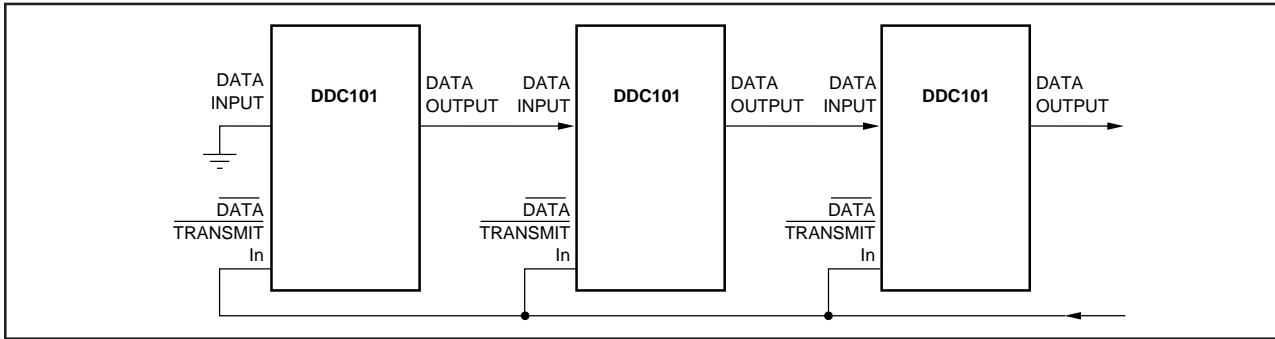

FIGURE 26. Daisy Chained DDC101s.

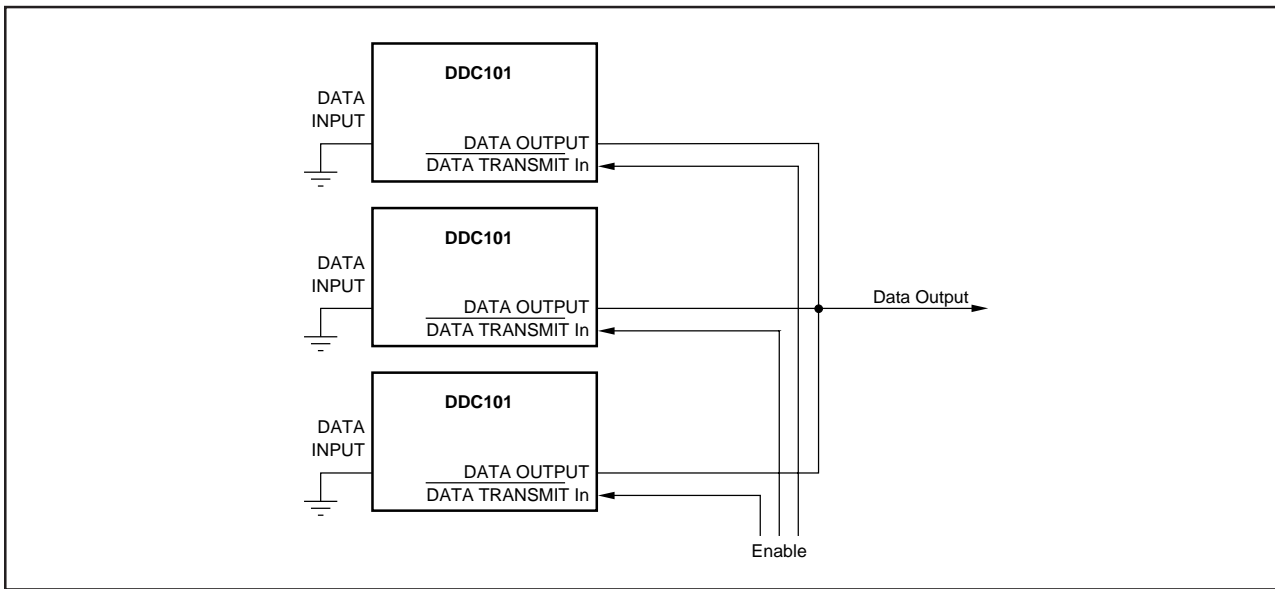

FIGURE 27. DDC101 Parallel Operation.

MULTIPLE DDC101 OPERATION

Multiple DDC101 units can be connected in serial or parallel configuration as illustrated in Figures 26 and 27.

DATA OUTPUT can be used with DATA INPUT to “daisy chain” the output of several DDC101 units together to minimize wiring; in this mode of operation, the serial data output is shifted through multiple DDC101s (Figure 26).

DATA OUTPUT is in a high impedance state until DATA TRANSMIT In is active. In this way, several DDC101 units can be connected in parallel to be enabled by the DATA TRANSMIT In line (Figure 27).

DDC101 EVALUATION FIXTURE

The DEM-DDC101P-C Evaluation Fixture is highly recommended for initial evaluation of the DDC101. It is designed for ease of use. The only additional equipment required to do

a complete evaluation of the performance of the DDC101 is an IBM compatible PC with EGA or VGA graphics, a parallel interface port, a laser printer (optional), a $\pm 5\text{VDC}$ power supply, and a signal source.

The DEM-DDC101P-C software is mouse compatible and retrieves data from up to 32 DDC101s in an easy to read, graphical format on the screen. The DEM-DDC101P-C Evaluation Fixture includes a PC Interface Board (with necessary parts), a DDC101 Board, a 25-pin ribbon connector and a 34-pin ribbon connector. The PC Interface Board makes timing commands and access to and from the DDC101 test board possible through the provided PC software. Data sheet, LI-439, provides complete information describing the evaluation fixture.

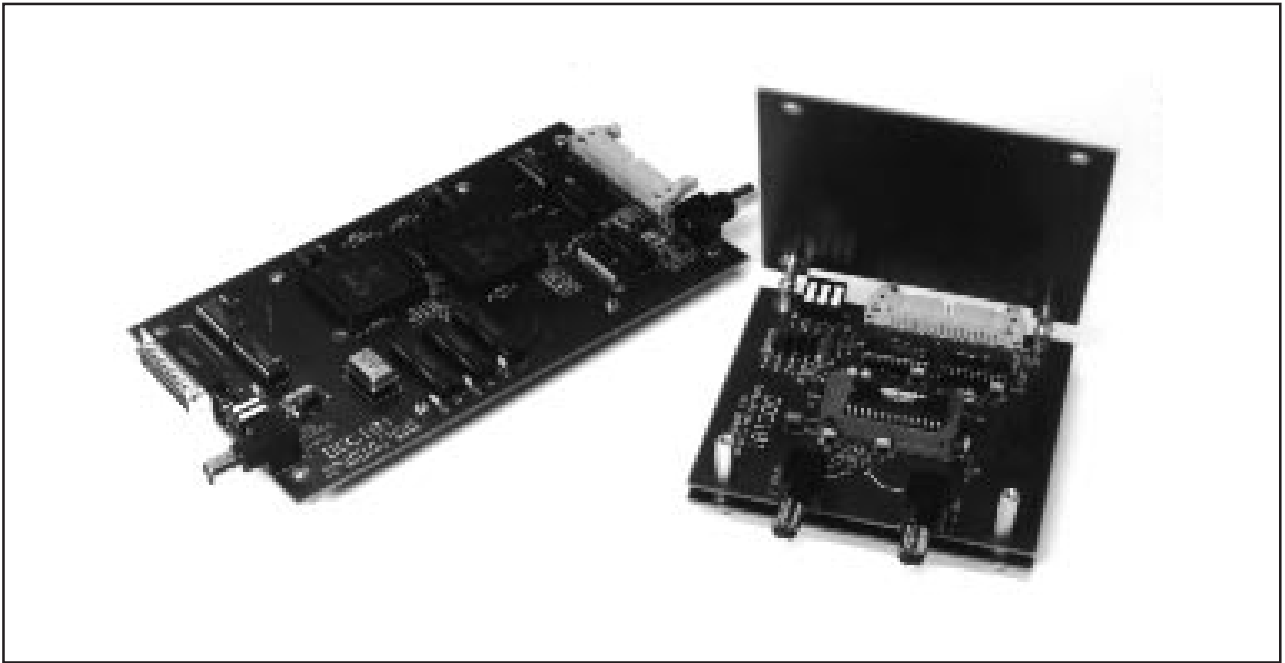

FIGURE 28. Photo of DEM-DDC101P-C Evaluation Fixture.

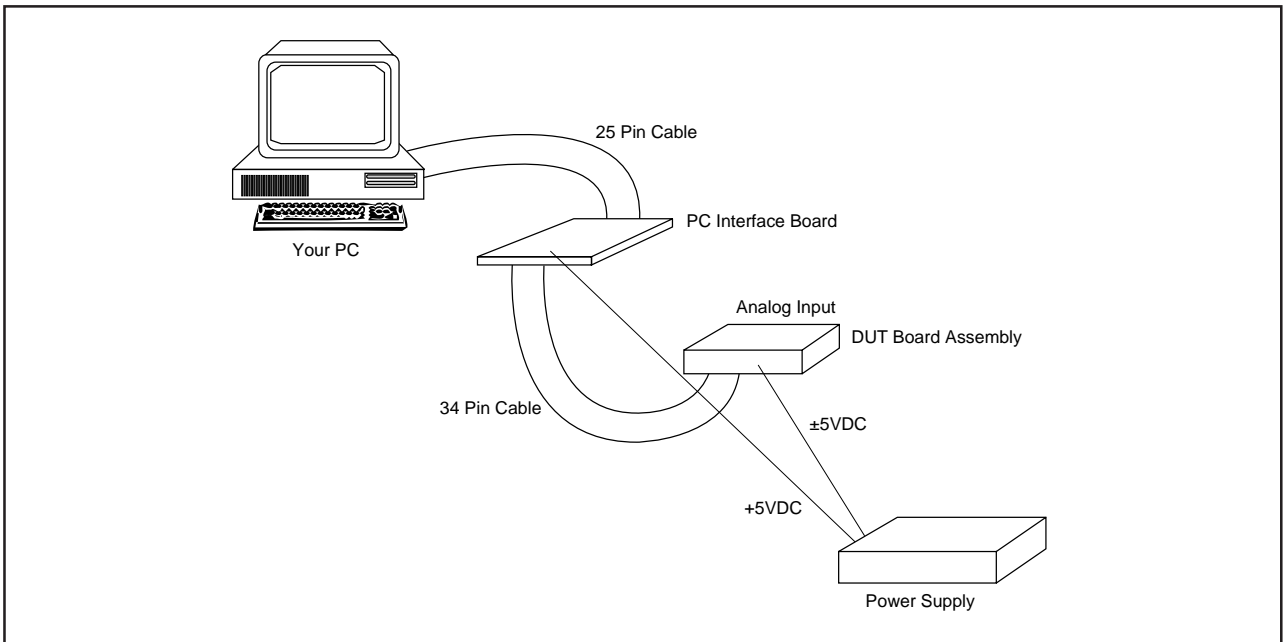

FIGURE 29. DEM-DDC101P-C Evaluation Fixture Connection Diagram.