

# SHINDENGEN

## Schottky Rectifiers (SBD)

Dual

# DE10PC3

### 30V 10A

#### FEATURES

- SMT
- Super low  $V_f=0.4V$
- High current capacity with Small Package

#### APPLICATION

- Reversed Battery Connection Protection
- DC OR output
- DC/DC converter
- Mobile telephone, personal computer

### OUTLINE DIMENSIONS

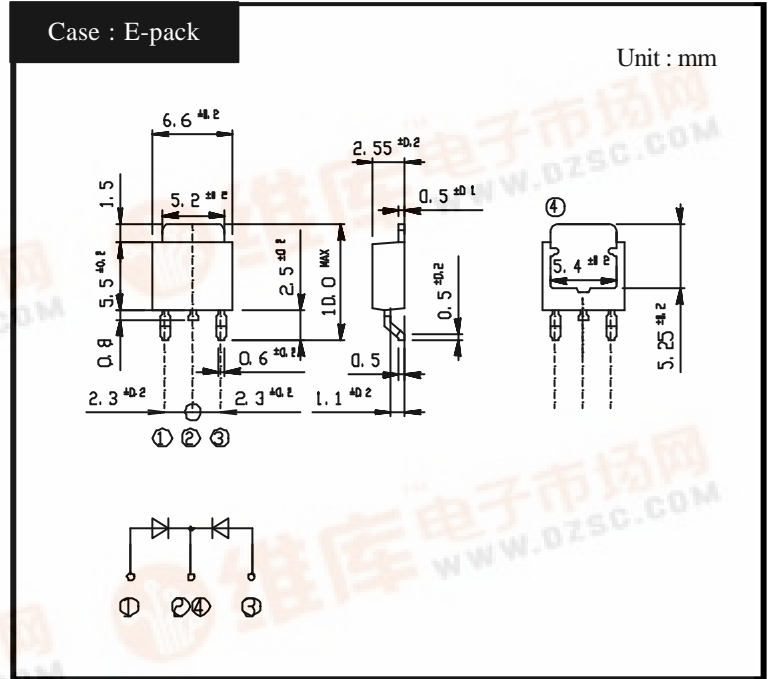

### RATINGS

Absolute Maximum Ratings (If not specified  $T_c=25$  )

Item	Symbol	Conditions	Ratings	Unit
Storage Temperature	$T_{stg}$		-55 ~ 125	
Operating Junction Temperature	$T_j$		125	
Maximum Reverse Voltage	$V_{RM}$		30	V
Repetitive Peak Surge Reverse Voltage	$V_{RRSM}$	Pulse width 0.5ms, duty 1/40	35	V
Average Rectified Forward Current	$I_o$	50Hz sine wave, R-load, Rating for each diode $I_o/2$ , $T_c=97$	10	A
Peak Surge Forward Current	$I_{FSM}$	50Hz sine wave, Non-repetitive 1 cycle peak value, $T_j=25$	80	A

Electrical Characteristics (If not specified  $T_c=25$  )

Item	Symbol	Conditions	Ratings	Unit
Forward Voltage	$V_F$	$I_F=4A$ , Pulse measurement, Rating of per diode	Max.0.40	V
Reverse Current	$I_R$	$V_R=V_{RM}$ , Pulse measurement, Rating of per diode	Max.10	mA
Junction Capacitance	$C_j$	$f=1MHz$ , $V_R=10V$ , Rating of per diode	Typ.290	pF
Thermal Resistance	$\theta_c$	junction to case	Max.4.0	/W



# DE10PC3

## Forward Voltage

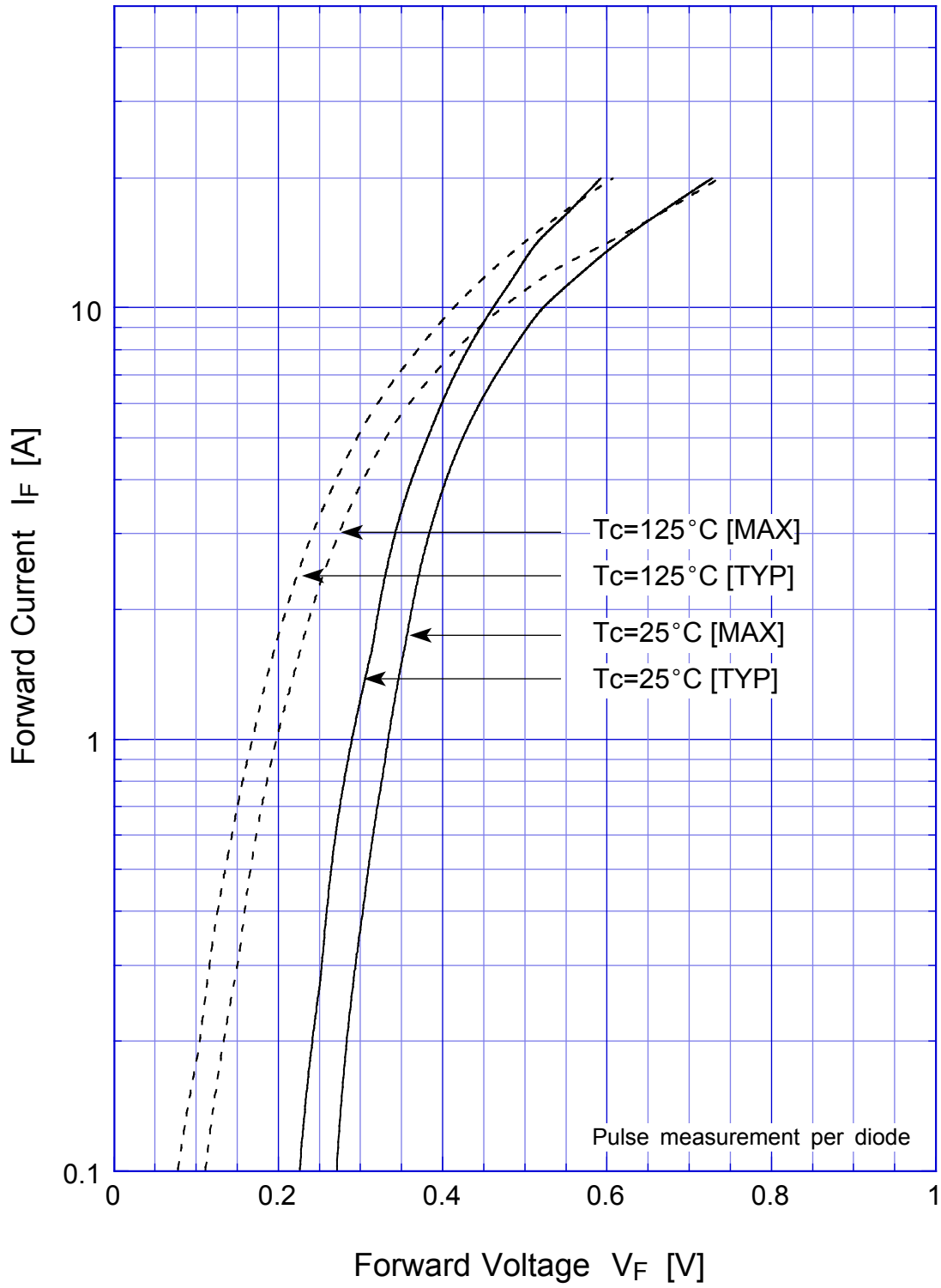

# DE10PC3

## Junction Capacitance

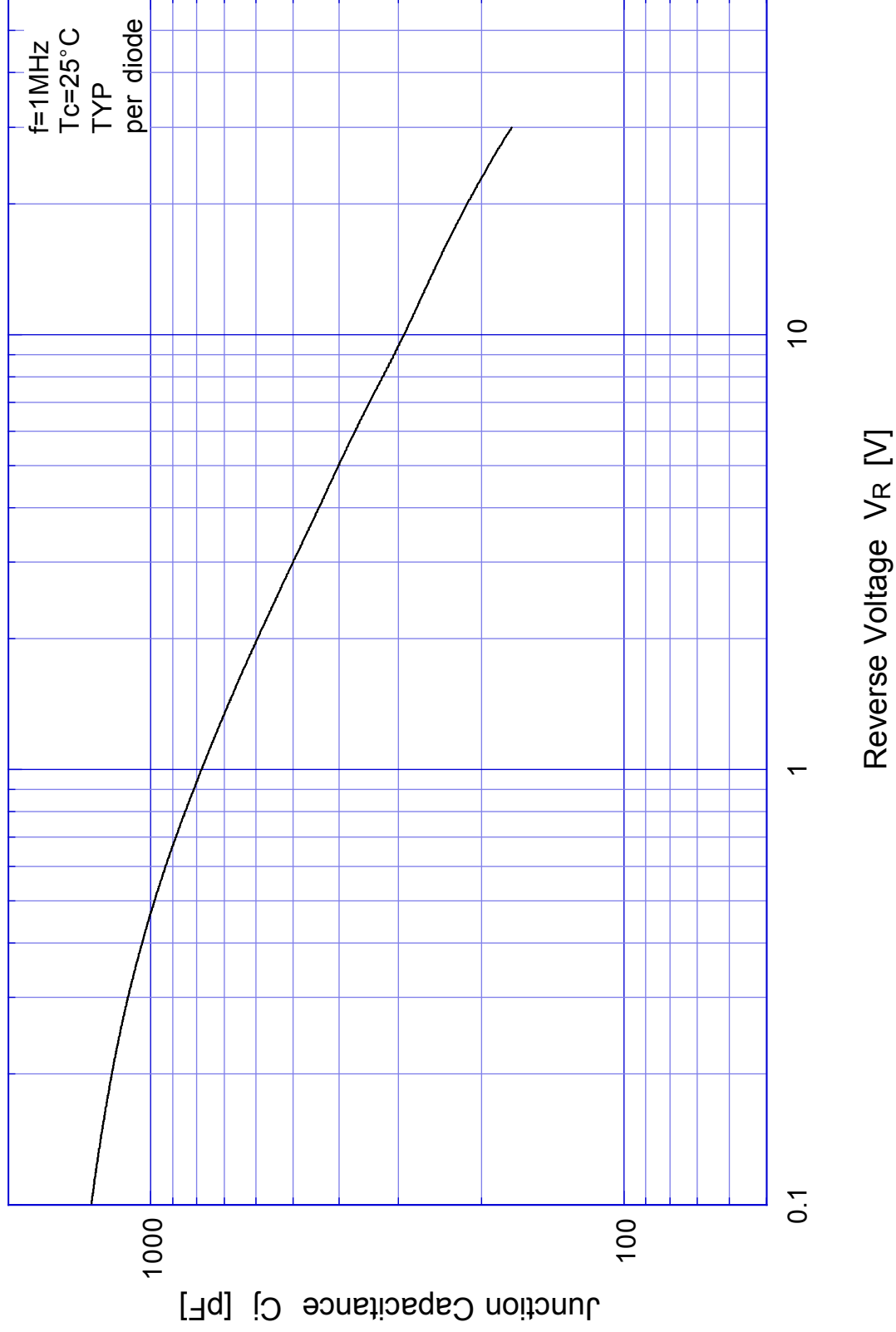

# DE10PC3 Reverse Current

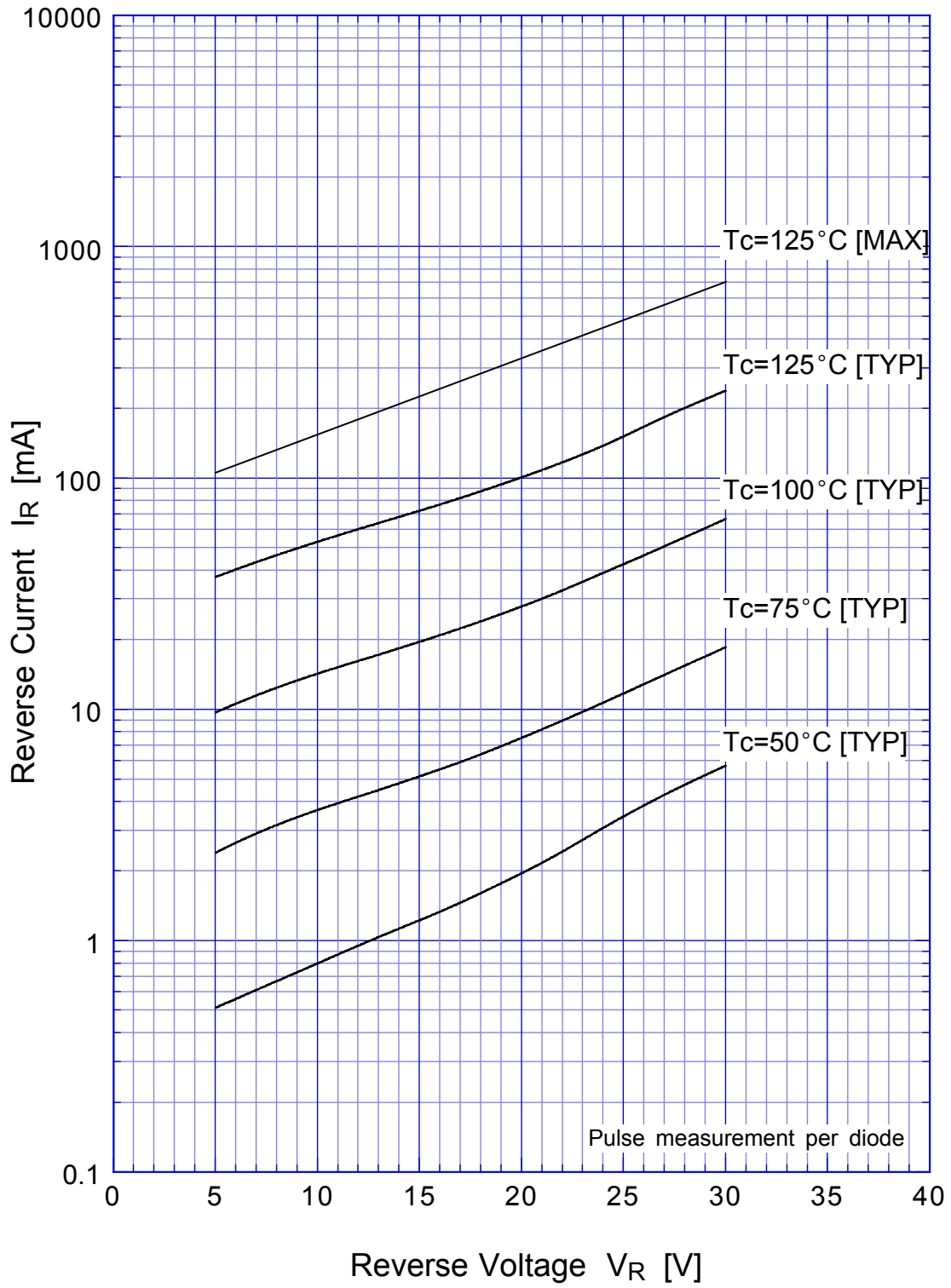

# DE10PC3 Reverse Power Dissipation

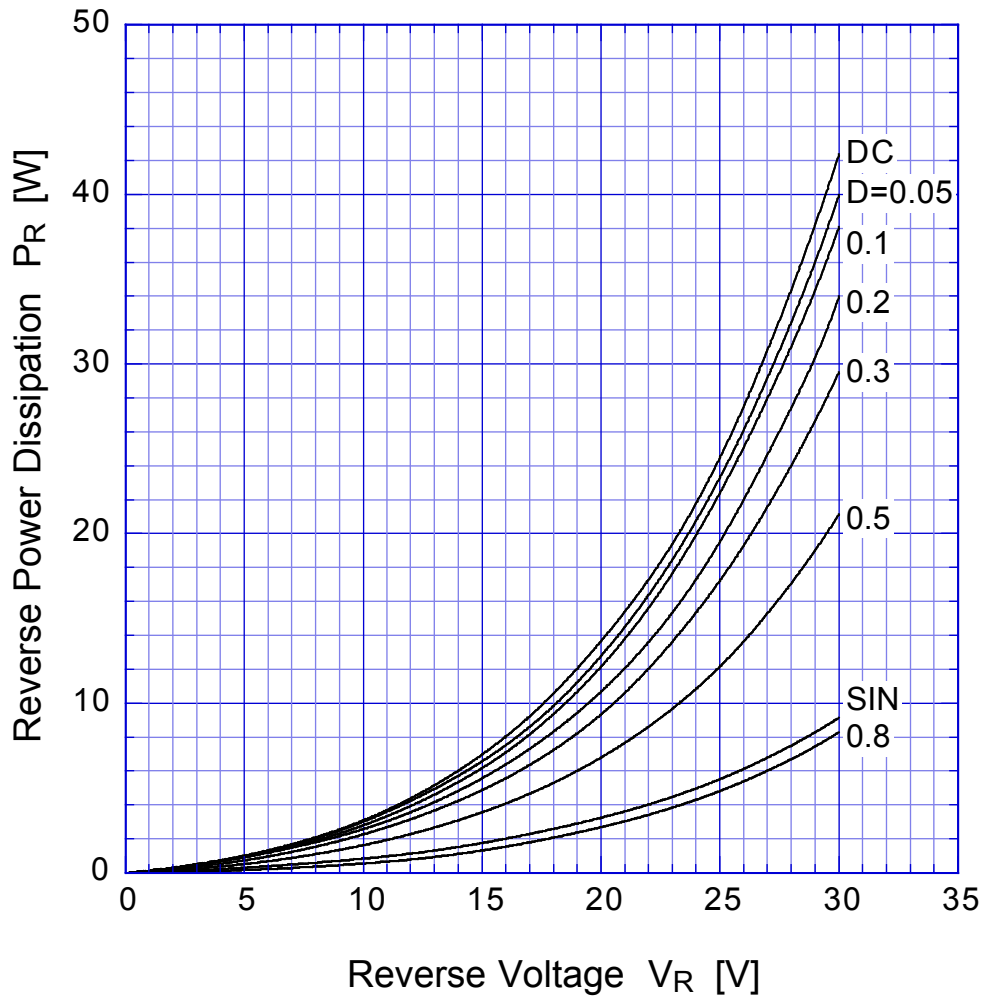

$T_j = 125^\circ\text{C}$

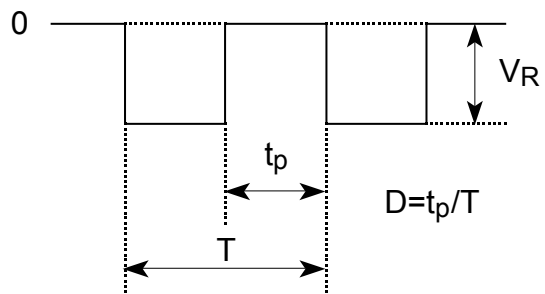

## DE10PC3 Forward Power Dissipation

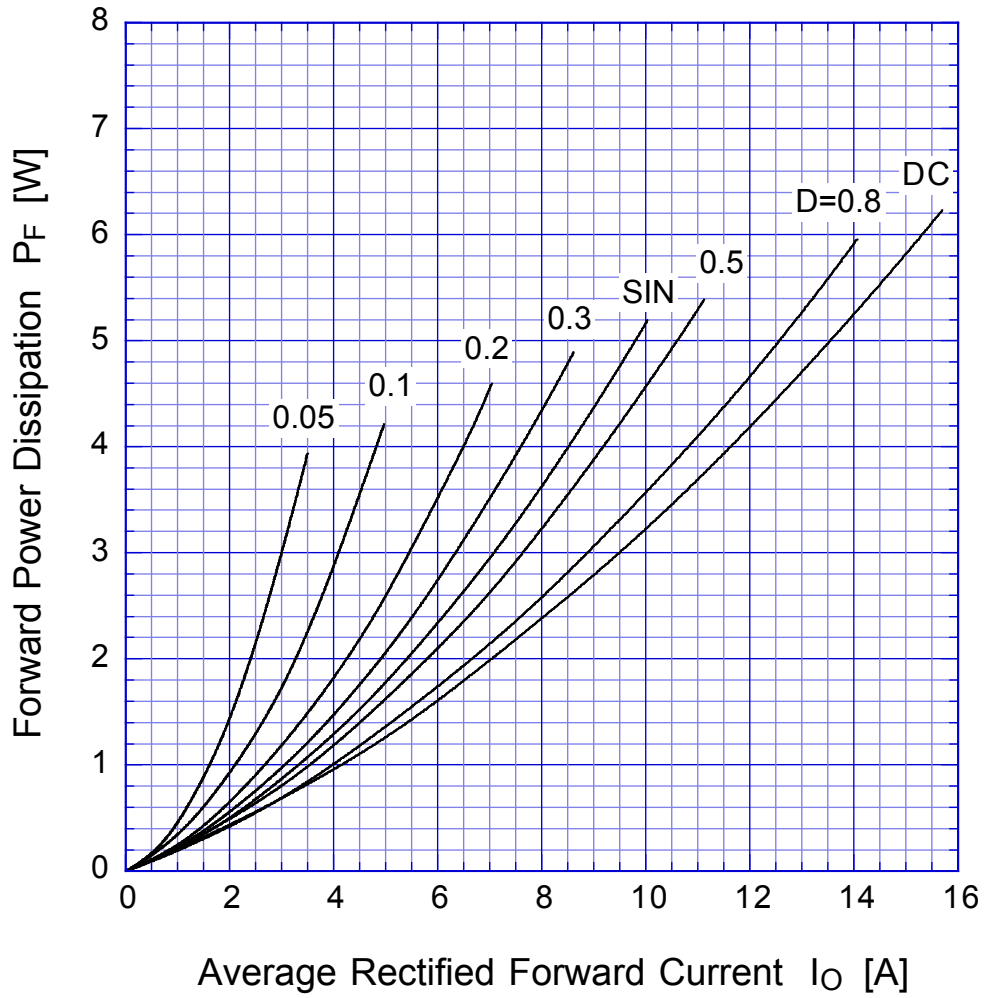

$T_j = 125^\circ\text{C}$

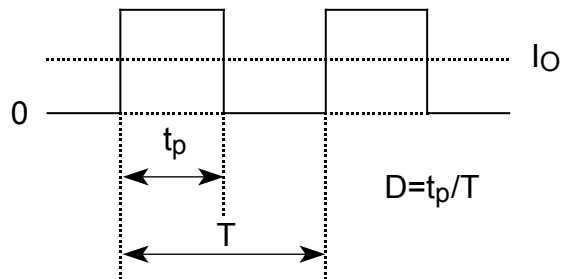

# DE10PC3

# Derating Curve

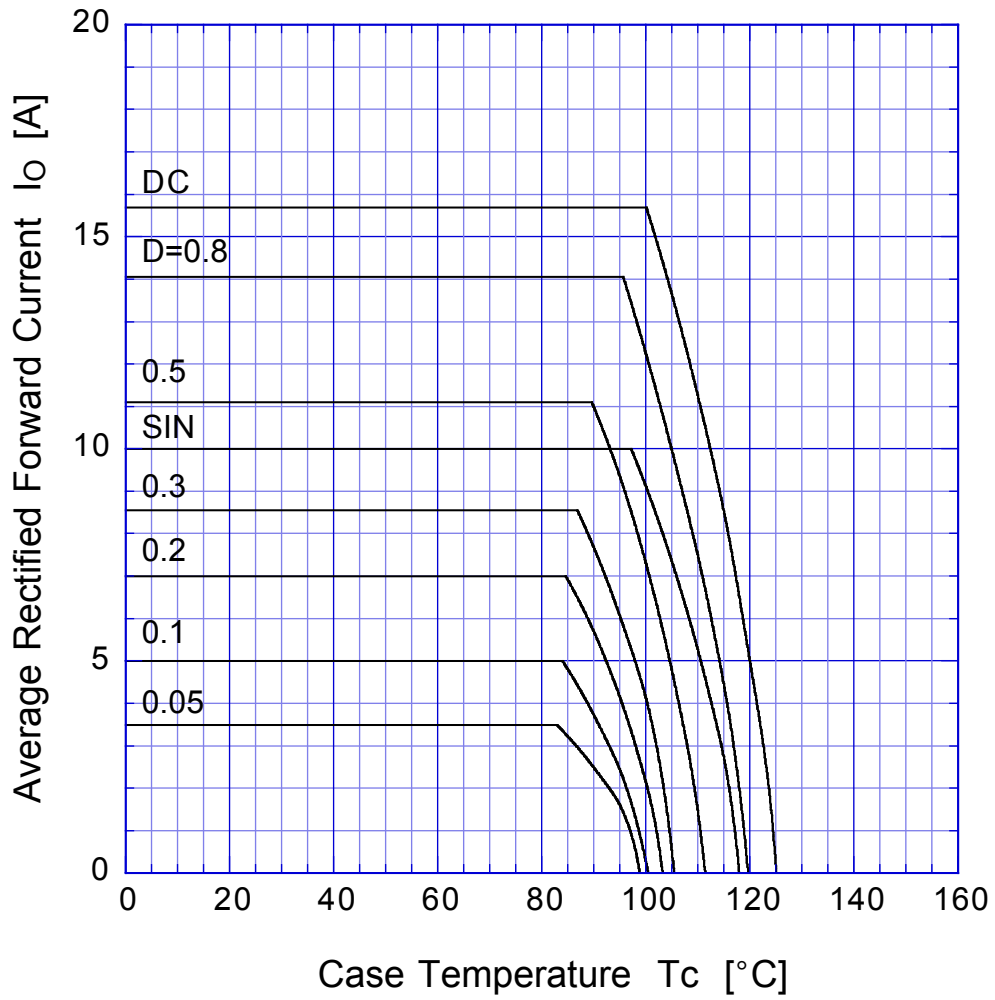

$V_R = 15V$

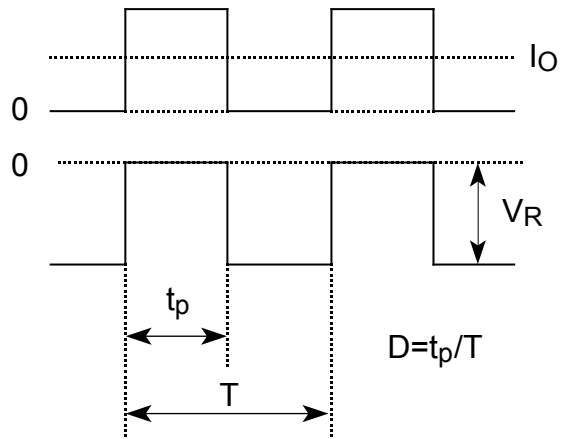

# DE10PC3 Peak Surge Forward Capability

