

N-Channel Enhancement Mode
Avalanche Rated
Low Q_g and R_g
High dv/dt
Nanosecond Switching

Preliminary Data Sheet

$V_{DSS} = 500\text{ V}$
 $I_{D25} = 4.5\text{ A}$
 $R_{DS(on)} = 1.5\ \Omega$
 $P_{DHS} = 80\text{ W}$

Symbol	Test Conditions	Maximum Ratings	
V_{DSS}	$T_J = 25^\circ\text{C}$ to 150°C	500	V
V_{DGR}	$T_J = 25^\circ\text{C}$ to 150°C ; $R_{GS} = 1\text{ M}\Omega$	500	V
V_{GS}	Continuous	± 20	V
V_{GSM}	Transient	± 30	V
I_{D25}	$T_c = 25^\circ\text{C}$	4.5	A
I_{DM}	$T_c = 25^\circ\text{C}$, pulse width limited by T_{JM}	27	A
I_{AR}	$T_c = 25^\circ\text{C}$	4.5	A
E_{AR}	$T_c = 25^\circ\text{C}$	-	mJ
dv/dt	$I_S \leq I_{DM}$, $di/dt \leq 100\text{ A}/\mu\text{s}$, $V_{DD} \leq V_{DSS}$, $T_J \leq 150^\circ\text{C}$, $R_G = 0.2\ \Omega$	3.5	V/ns
	$I_S = 0$	>200	V/ns
P_{DHS}	$T_c = 25^\circ\text{C}$ Derate $4.4\text{ W}/^\circ\text{C}$ above 25°C	80	W
P_{DAMB}	$T_c = 25^\circ\text{C}$	3.5	W
T_J		-55...+150	$^\circ\text{C}$
T_{JM}		150	$^\circ\text{C}$
T_{stg}		-55...+150	$^\circ\text{C}$
T_L	1.6mm (0.063 in) from case for 10 s	300	$^\circ\text{C}$
Weight		2	g

Symbol	Test Conditions	Characteristic Values		
		$T_J = 25^\circ\text{C}$ unless otherwise specified		
		min.	typ.	max.
V_{DSS}	$V_{GS} = 0\text{ V}$, $I_D = 3\text{ ma}$	500		V
$V_{GS(th)}$	$V_{DS} = V_{GS}$, $I_D = 4\text{ ma}$	2	3	4 V
I_{GSS}	$V_{GS} = \pm 20\text{ V}_{DC}$, $V_{DS} = 0$			$\pm 100\text{ nA}$
I_{DSS}	$V_{DS} = 0.8\text{ V}_{DSS}$, $T_J = 25^\circ\text{C}$ $V_{GS} = 0$, $T_J = 125^\circ\text{C}$			25 μA 250 μA
$R_{DS(on)}$	$V_{GS} = 15\text{ V}$, $I_D = 0.5I_{D25}$ Pulse test, $t \leq 300\ \mu\text{s}$, duty cycle $d \leq 2\%$			1.5 Ω
g_{fs}	$V_{DS} = 15\text{ V}$, $I_D = 0.5I_{D25}$, pulse test	2.7	4.0	S

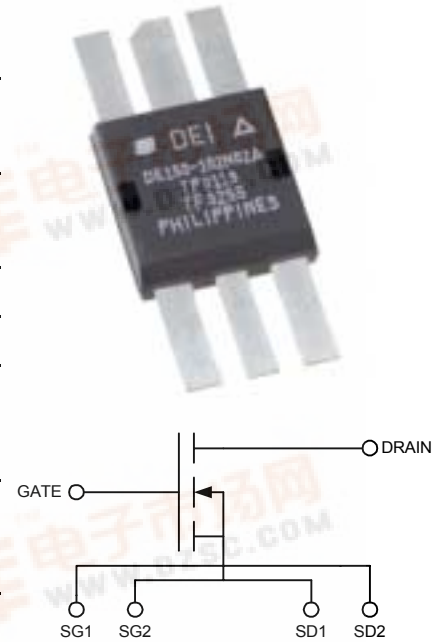

Features

- Isolated Substrate
 - high isolation voltage (>2500V)
 - excellent thermal transfer
 - Increased temperature and power cycling capability
- IXYS advanced low Q_g process
- Low gate charge and capacitances
 - easier to drive
 - faster switching
- Low $R_{DS(on)}$
- Very low insertion inductance (<2nH)
- No beryllium oxide (BeO) or other hazardous materials

Advantages

- Optimized for RF and high speed switching at frequencies to >100MHz
- Easy to mount—no insulators needed
- High power density



Symbol	Test Conditions	Characteristic Values		
		(T _J = 25°C unless otherwise specified)		
		min.	typ.	max.
R _G				5 Ω
C _{iss}			600	pF
C _{oss}	V _{GS} = 0 V, V _{DS} = 0.8 V _{DSS(max)} , f = 1 MHz		50	pF
C _{riss}			5	pF
T _{d(on)}			4	ns
T _{on}	V _{GS} = 15 V, V _{DS} = 0.8 V _{DSS} I _D = 0.5 I _{DM}		4	ns
T _{d(off)}	R _G = 0.2 Ω (External)		4	ns
T _{off}			4	ns
Q _{g(on)}		16		40 nC
Q _{gs}	V _{GS} = 10 V, V _{DS} = 0.5 V _{DSS} I _D = 0.5 I _{D25}	2.0		6.0 nC
Q _{gd}		8.0		20 nC
R _{thJHS}			1.5	K/W

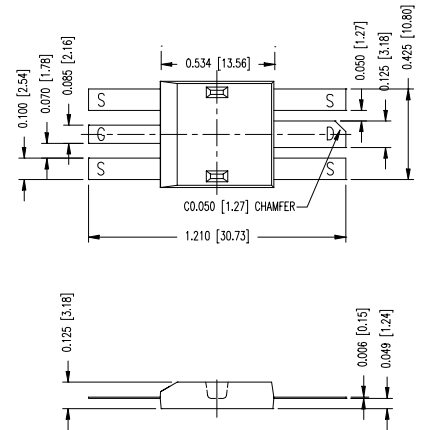

Symbol	Test Conditions	Characteristic Values		
		(T _J = 25°C unless otherwise specified)		
		min.	typ.	max.
I _S	V _{GS} = 0 V			4.5 A
I _{SM}	Repetitive; pulse width limited by T _{JM}			27 A
V _{SD}	I _F = I _S , V _{GS} = 0 V, Pulse test, t ≤ 300 μs, duty cycle ≤ 2%			1.4 V
T _{rr}			900	ns

Directed Energy, Inc. reserves the right to change limits, test conditions and dimensions.

DEI MOSFETS are covered by one or more of the following U.S. patents:

4,835,592	4,850,072	4,881,106	4,891,686	4,931,844	5,017,508
5,034,796	5,049,961	5,063,307	5,187,117	5,237,481	5,486,715
5,381,025	5,640,045				

501N04A DE-SERIES SPICE Model

The DE-SERIES SPICE Model is illustrated in Figure 1. The model is an expansion of the SPICE level 3 MOSFET model. It includes the stray inductive terms L_G , L_S and L_D . R_d is the $R_{DS(ON)}$ of the device, R_{ds} is the resistive leakage term. The output capacitance, C_{OSS} , and reverse transfer capacitance, C_{RSS} are modeled with reversed biased diodes. This provides a varactor type response necessary for a high power device model. The turn on delay and the turn off delay are adjusted via R_{on} and R_{off} .

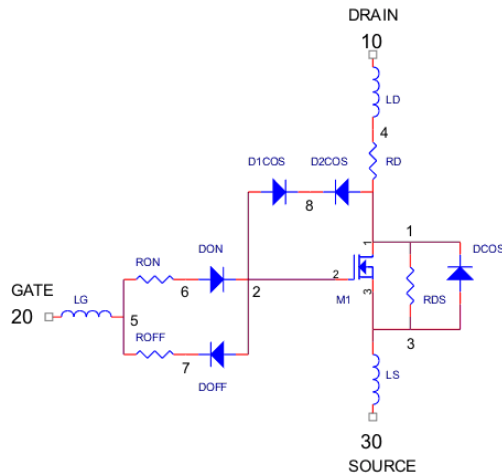

Figure 1 DE-SERIES SPICE Model

This SPICE model may be downloaded as a text file from the DEI web site at www.directedenergy.com/spice.htm

Net List:

```
*SYM=POWMOSN
.SUBCKT 501N04A 10 20 30
* TERMINALS: D G S
* 500 Volt 4.5 Amp 1.5 Ohm N-Channel Power MOSFET 10-30-2001
M1 1 2 3 3 DMOS L=1U W=1U
RON 5 6 9.5
DON 6 2 D1
ROF 5 7 3.5
DOF 2 7 D1
D1CRS 2 8 D2
D2CRS 1 8 D2
CGS 2 3 .6N
RD 4 1 1.5
DCOS 3 1 D3
RDS 1 3 5.0MEG
LS 3 30 .1N
LD 10 4 1N
LG 20 5 1N
.MODEL DMOS NMOS (LEVEL=3 VTO=3.0 KP=6.0)
.MODEL D1 D (IS=.5F CJO=1P BV=100 M=.5 VJ=.6 TT=1N)
.MODEL D2 D (IS=.5F CJO=175P BV=500 M=.5 VJ=.6 TT=1N RS=10M)
.MODEL D3 D (IS=.5F CJO=250P BV=500 M=.3 VJ=.4 TT=400N RS=10M)
.ENDS
```

Doc #9200-0240 Rev 1
© 2001 Directed Energy, Inc.