



DE375-102N10A
RF Power MOSFET

N-Channel Enhancement Mode
Low Q_g and R_g
High dv/dt
Nanosecond Switching

$V_{DSS} = 1000\text{ V}$
 $I_{D25} = 10\text{ A}$
 $R_{DS(on)} = 1.2\ \Omega$
 $P_{DC} = 940\text{ W}$

Symbol	Test Conditions	Maximum Ratings	
V_{DSS}	$T_J = 25^\circ\text{C}$ to 150°C	1000	V
V_{DGR}	$T_J = 25^\circ\text{C}$ to 150°C ; $R_{GS} = 1\text{ M}\Omega$	1000	V
V_{GS}	Continuous	± 20	V
V_{GSM}	Transient	± 30	V
I_{D25}	$T_c = 25^\circ\text{C}$	10	A
I_{DM}	$T_c = 25^\circ\text{C}$, pulse width limited by T_{JM}	60	A
I_{AR}	$T_c = 25^\circ\text{C}$	10	A
E_{AR}	$T_c = 25^\circ\text{C}$	30	mJ
dv/dt	$I_S \leq I_{DM}$, $di/dt \leq 100\text{ A}/\mu\text{s}$, $V_{DD} \leq V_{DSS}$, $T_J \leq 150^\circ\text{C}$, $R_G = 0.2\ \Omega$	5	V/ns
	$I_S = 0$	>200	V/ns
P_{DC}		940	W
P_{DHS}	$T_c = 25^\circ\text{C}$ Derate $4.4\text{ W}/^\circ\text{C}$ above 25°C	425	W
P_{DAMB}	$T_c = 25^\circ\text{C}$	4.5	W
R_{thJC}		0.16	C/W
R_{thJHS}		0.23	C/W

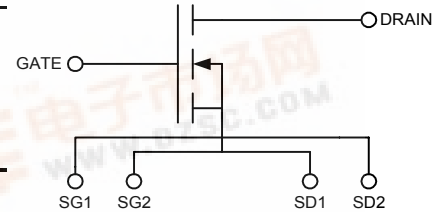
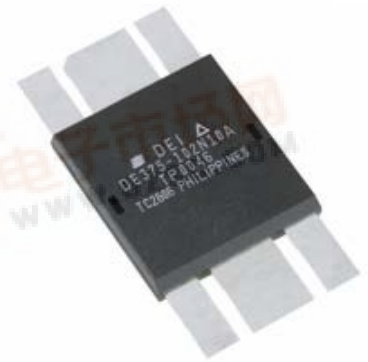

Symbol	Test Conditions	Characteristic Values		
		$T_J = 25^\circ\text{C}$ unless otherwise specified		
		min.	typ.	max.
V_{DSS}	$V_{GS} = 0\text{ V}$, $I_D = 3\text{ ma}$	1000		V
$V_{GS(th)}$	$V_{DS} = V_{GS}$, $I_D = 4\text{ ma}$	2.5		5.5 V
I_{GSS}	$V_{GS} = \pm 20\text{ V}_{DC}$, $V_{DS} = 0$			$\pm 100\text{ nA}$
I_{DSS}	$V_{DS} = 0.8\text{ V}_{DSS}$, $T_J = 25^\circ\text{C}$ $V_{GS} = 0$, $T_J = 125^\circ\text{C}$			50 μA 1 mA
$R_{DS(on)}$	$V_{GS} = 15\text{ V}$, $I_D = 0.5I_{D25}$ Pulse test, $t \leq 300\ \mu\text{s}$, duty cycle $d \leq 2\%$			1.2 Ω
g_{fs}	$V_{DS} = 15\text{ V}$, $I_D = 0.5I_{D25}$, pulse test	6	18	S
T_J		-55		+150 $^\circ\text{C}$
T_{JM}			150	$^\circ\text{C}$
T_{stg}		-55		+150 $^\circ\text{C}$
l_L	1.6mm (0.063 in) from case for 10 s		300	$^\circ\text{C}$
Weight			3	g

Features

- Isolated Substrate
 - high isolation voltage (>2500V)
 - excellent thermal transfer
 - Increased temperature and power cycling capability
- IXYS advanced low Q_g process
- Low gate charge and capacitances
 - easier to drive
 - faster switching
- Low $R_{DS(on)}$
- Very low insertion inductance (<2nH)
- No beryllium oxide (BeO) or other hazardous materials

Advantages

- Optimized for RF and high speed switching at frequencies to 50MHz
- Easy to mount—no insulators needed
- High power density



Symbol	Test Conditions	Characteristic Values		
		min.	typ.	max.
R_G			0.3	Ω
C_{iss}			2900	pF
C_{oss}	$V_{GS} = 0\text{ V}, V_{DS} = 0.8 V_{DSS(max)}, f = 1\text{ MHz}$		100	pF
C_{rss}			25	pF
C_{stray}	Back Metal to any Pin		33	pF
$T_{d(on)}$			5	ns
T_{on}	$V_{GS} = 15\text{ V}, V_{DS} = 0.8 V_{DSS}, I_D = 0.5 I_{DM}$		3	ns
$T_{d(off)}$	$R_G = 0.2\ \Omega$ (External)		5	ns
T_{off}			8	ns
$Q_{g(on)}$			90	nC
Q_{gs}	$V_{GS} = 10\text{ V}, V_{DS} = 0.5 V_{DSS}, I_D = 0.5 I_{D25}$		30	nC
Q_{gd}			40	nC

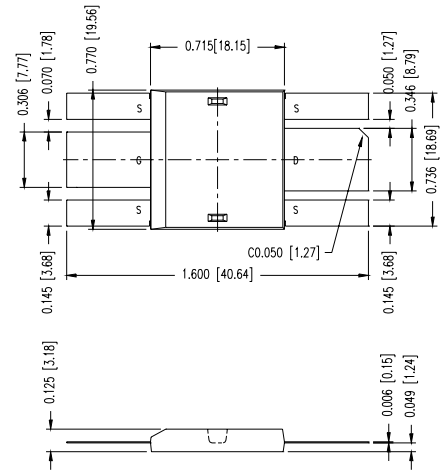

Source-Drain Diode -		Characteristic Values		
		(T _J = 25°C unless otherwise specified)		
Symbol	Test Conditions	min.	typ.	max.
I_S	$V_{GS} = 0\text{ V}$			10 A
I_{SM}	Repetitive; pulse width limited by T _{JM}			80 A
V_{SD}	$I_F = I_S, V_{GS} = 0\text{ V},$ Pulse test, t ≤ 300 μs, duty cycle ≤ 2%			1.5 V
T_{rr}			200	ns
Q_{RM}	$I_F = I_S, -di/dt = 100A/\mu s,$ $V_R = 100V$		0.6	μC
I_{RM}			7	A

(1) These parameters apply to the package, not individual MOSFET devices.

For detailed device mounting and installation instructions, see the “DE-Series MOSFET Mounting Instructions” technical note on IXYS RF’s web site at www.ixysrf.com/Technical_Support/App_notes.html

IXYS RF reserves the right to change limits, test conditions and dimensions.

IXYS RF MOSFETS are covered by one or more of the following U.S. patents:

- | | | | | | |
|-----------|-----------|-----------|-----------|-----------|-----------|
| 4,835,592 | 4,850,072 | 4,881,106 | 4,891,686 | 4,931,844 | 5,017,508 |
| 5,034,796 | 5,049,961 | 5,063,307 | 5,187,117 | 5,237,481 | 5,486,715 |
| 5,381,025 | 5,640,045 | | | | |

102N10A DE-SERIES SPICE Model

The DE-SERIES SPICE Model is illustrated in Figure 1. The model is an expansion of the SPICE level 3 MOSFET model. It includes the stray inductive terms L_G , L_S and L_D . R_d is the $R_{DS(ON)}$ of the device, R_{ds} is the resistive leakage term. The output capacitance, C_{OSS} , and reverse transfer capacitance, C_{RSS} are modeled with reversed biased diodes. This provides a varactor type response necessary for a high power device model. The turn on delay and the turn off delay are adjusted via R_{on} and R_{off} .

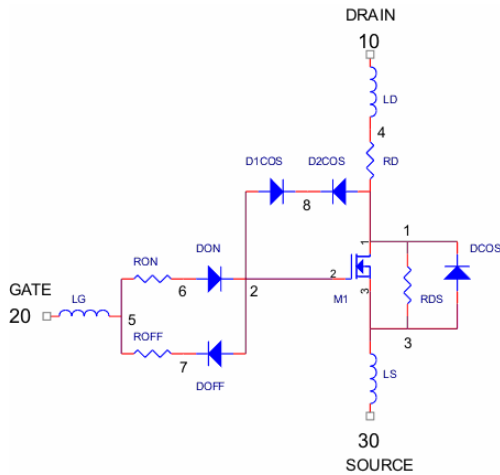

Figure 1 DE-SERIES SPICE Model

This SPICE model may be downloaded as a text file from the DEI web site at www.directedenergy.com/spice.htm

Net List:

```
.SUBCKT 102N10A 10 20 30
* TERMINALS: D G S
* 1000 Volt 10 Amp 1.2 ohm N-Channel Power MOSFET
* REV.A 05-23-00
M1 1 2 3 3 DMOS L=1U W=1U
RON 5 6 0.5
DON 6 2 D1
ROFF 5 7 .1
DOFF 2 7 D1
D1CRS 2 8 D2
D2CRS 1 8 D2
CGS 2 3 3.0N
RD 4 1 1.5
DCOS 3 1 D3
RDS 1 3 5.0MEG
LS 3 30 .5N
LD 10 4 1N
LG 20 5 1N
.MODEL DMOS NMOS (LEVEL=3 VTO=3.0 KP=3.8)
.MODEL D1 D (IS=.5F CJO=1P BV=100 M=.5 VJ=.6 TT=1N)
.MODEL D2 D (IS=.5F CJO=400P BV=1000 M=.4 VJ=.6 TT=400N RS=10M)
.MODEL D3 D (IS=.5F CJO=900P BV=1000 M=.3 VJ=.4 TT=400N RS=10M)
.ENDS
```

Doc #9200-0223 Rev 6
© 2003 IXYS RF