

DIODE(THREE PHASES BRIDGE TYPE)

DF20CA80/120/160

UL;E76102 (M)

Power Diode Module DF20CA is designed for three phase full wave rectification, which has six diodes connected in a three phase bridge configuration. The mounting base of the module is electrically isolated from semiconductor elements for simple heatsink construction output DC current is 20Amp (Tc=123°C) Repetitive peak reverse voltage is up to 1,600V.

- IFSM=550/600A (50/60Hz)
- TjMax=150°C
- Isolated Mounting Base
- High reliability by unique glass passivation
- Easy Assemble by the #250 terminal Tab

(Applications)

AC. DC Moter Drive/AVR/Switching
—for three phase rectification

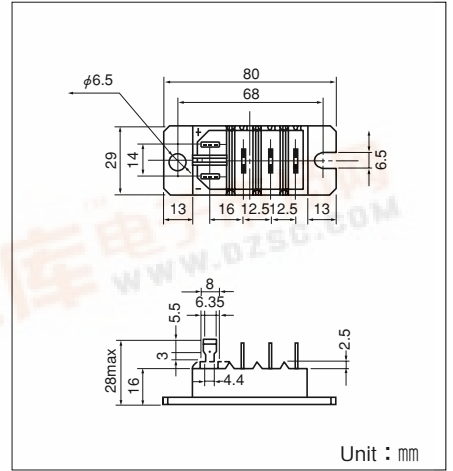
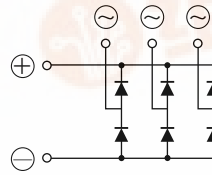

Maximum Ratings

(Tj=25°C unless otherwise specified)

Symbol	Item	Ratings			Unit
		DF20CA80	DF20CA120	DF20CA160	
VRRM	Repetitive Peak Reverse Voltage	800	1200	1600	V
VRSM	Non-Repetitive Peak Reverse Voltage	960	1300	1700	V

Symbol	Item	Conditions	Ratings	Unit	
Id	Output current (D.C.)	Three phase. full wave. Tc=123°C	20	A	
IFSM	Surage Forward Current	1 cycle, 50/60Hz, peak value, non-repetitive	550/600	A	
Tj	Junction Temperature		-40 to +150	°C	
Tstg	Storge Temperature		-40 to +125	°C	
VI50	Isolation Breakdown Voltage (R.M.S.)	Main Terminal to case 1minute	2500	V	
	Mounting Torque	Mounting (M6)	Recommended Value 2.5-3.9 (25-40)	4.7 (48)	N·m (kgf·cm)
		Terminal	Tub Terminal # 250	—	
	Mass	Typical Value	90	g	

Electrical Characteristics

Symbol	Item	Conditions	Ratings	Unit
IRRM	Repetitive Peak Reverse Current, max.	Tj=150°C at VRRM	8.0	mA
VFM	Forward Voltage Drop, max.	IFM=20A, Tj=25°C Inst. measurement	1.1	V
Rth(j-c)	Thermal Impedance, max.	Junction to case	0.6	°C/W



DF20CA80/120/160

