

Quad SPST CMOS Analog Switches

FEATURES

- Low On-Resistance: 50 Ω
- Low Leakage: 80 pA
- Low Power Consumption: 22 nW
- Fast Switching Action— t_{ON} : 120 ns
- Low Charge Injection
- DG211/DG212 Upgrades
- TTL/CMOS Logic Compatible

BENEFITS

- Low Signal Errors and Distortion
- Reduced Power Supply Requirements
- Faster Throughput
- Improved Reliability
- Reduced Pedestal Errors
- Simple Interfacing

APPLICATIONS

- Audio Switching
- Battery Powered Systems
- Data Acquisition
- Sample-and-Hold Circuits
- Telecommunication Systems
- Automatic Test Equipment
- Single Supply Circuits
- Hard Disk Drives

DESCRIPTION

The DG444/DG445 monolithic quad analog switches are designed to provide high speed, low error switching of analog signals. The DG444 has a normally closed function. The DG445 has a normally open function. Combining low power (22 nW, typ) with high speed (t_{ON} : 120 ns, typ), the DG444/DG445 are ideally suited for upgrading DG211/212 sockets. Charge injection has been minimized on the drain for use in sample-and-hold circuits.

To achieve high-voltage ratings and superior switching performance, the DG444/DG445 are built on Vishay Siliconix's high-voltage silicon-gate process. An epitaxial layer prevents latchup.

Each switch conducts equally well in both directions when on, and blocks input voltages to the supply levels when off.

FUNCTIONAL BLOCK DIAGRAM AND PIN CONFIGURATION

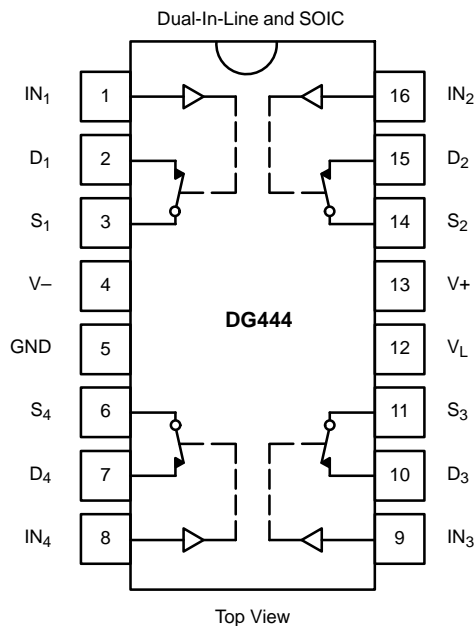

TRUTH TABLE		
Logic	DG444	DG445
0	ON	OFF
1	OFF	ON

Logic "0" \leq 0.8 V
Logic "1" \geq 2.4 V

ORDERING INFORMATION		
Temp Range	Package	Part Number
-40°C to 85°C	16-Pin Plastic DIP	DG444DJ
		DG445DJ
	16-Pin Narrow SOIC	DG444DY
		DG445DY



ABSOLUTE MAXIMUM RATINGS

V+ to V-	44 V
GND to V-	25 V
V _L	(GND -0.3 V) to (V+) + 0.3 V
Digital Inputs ^a V _S , V _D	(V-) -2 V to (V+) +2 V or 30 mA, whichever occurs first
Continuous Current (Any Terminal)	30 mA
Current, S or D (Pulsed 1 ms, 10% duty cycle)	100 mA
Storage Temperature	-65 to 125°C

Power Dissipation (Package) ^b	
16-Pin Plastic DIP ^c	450 mW
16-Pin Narrow Body SOIC ^d	640 mW

- Notes:
- Signals on S_X, D_X, or I_{NX} exceeding V+ or V- will be clamped by internal diodes. Limit forward diode current to maximum current ratings.
 - All leads welded or soldered to PC Board.
 - Derate 6 mW/°C above 75°C
 - Derate 8 mW/°C above 75°C

SPECIFICATIONS FOR DUAL SUPPLIES									
Parameter	Symbol	Test Conditions Unless Otherwise Specified V+ = 15 V, V- = -15 V V _L = 5 V, V _{IN} = 2.4 V, 0.8 V ^e	Temp ^a	D Suffix -40 to 85°C			Unit		
				Min ^b	Typ ^c	Max ^b			
Analog Switch									
Analog Signal Range ^d	V _{ANALOG}		Full	-15		15	V		
Drain-Source On-Resistance	r _{DS(on)}	I _S = -10 mA, V _D = ±8.5 V V+ = 13.5 V, V- = -13.5 V	Room Full		50	85 100	Ω		
Switch Off Leakage Current	I _{S(off)}	V+ = 16.5 V, V- = -16.5 V V _D = ±15.5 V, V _S = ∓15.5 V	Room Full	-0.5 -5	±0.01	0.5 5	nA		
	I _{D(off)}		Room Full	-0.5 -5	±0.01	0.5 5			
Channel On Leakage Current	I _{D(on)}	V+ = 16.5 V, V- = -16.5 V V _S = V _D = ±15.5 V	Room Full	-0.5 -10	±0.08	0.5 10			
Digital Control									
Input Current V _{IN} Low	I _{IL}	V _{IN} under test = 0.8 V All Other = 2.4 V	Full	-500	-0.01	500	nA		
Input Current V _{IN} High	I _{IH}	V _{IN} under test = 2.4 V All Other = 0.8 V	Full	-500	0.01	500			
Dynamic Characteristics									
Turn-On Time	t _{ON}	R _L = 1 kΩ, C _L = 35 pF V _S = ±10 V, See Figure 2	Room			120	250	ns	
Turn-Off Time	t _{OFF}		DG444	Room			110		140
			DG445	Room			160		210
Charge Injection ^e	Q	C _L = 1 nF, V _S = 0 V V _{gen} = 0 V, R _{gen} = 0 Ω	Room			-1		pC	
Off Isolation ^e	OIRR	R _L = 50 Ω, C _L = 5 pF, f = 1 MHz	Room			60		dB	
Crosstalk (Channel-to-Channel) ^d	X _{TALK}		Room			100			
Source Off Capacitance	C _{S(off)}	f = 1 MHz	Room			4		pF	
Drain Off Capacitance	C _{D(off)}		Room			4			
Channel On Capacitance	C _{D(on)}		V _{ANALOG} = 0 V	Room			16		
Power Supplies									
Positive Supply Current	I+	V+ = 16.5 V, V- = -16.5 V V _{IN} = 0 or 5 V	Room Full			0.001	1 5	μA	
Negative Supply Current	I-		Room Full	-1 -5		-0.0001			
Logic Supply Current	I _L		Room Full			0.001	1 5		
Ground Current	I _{GND}		Room Full	-1 -5		-0.001			



SPECIFICATIONS FOR UNIPOLAR SUPPLIES							
Parameter	Symbol	Test Conditions Unless Otherwise Specified $V_+ = 12\text{ V}, V_- = 0\text{ V}$ $V_L = 5\text{ V}, V_{IN} = 2.4\text{ V}, 0.8\text{ V}^e$	Temp ^a	D Suffix -40 to 85°C			Unit
				Min ^b	Typ ^c	Max ^b	
Analog Switch							
Analog Signal Range ^d	V_{ANALOG}		Full	0		12	V
Drain-Source On-Resistance ^d	$r_{DS(on)}$	$I_S = -10\text{ mA}, V_D = 3\text{ V}, 8\text{ V}$ $V_+ = 10.8\text{ V}, V_L = 5.25\text{ V}$	Room Full		100	160 200	Ω
Dynamic Characteristics							
Turn-On Time	t_{ON}	$R_L = 1\text{ k}\Omega, C_L = 35\text{ pF}, V_S = 8\text{ V}$ See Figure 2	Room		300	450	ns
Turn-Off Time	t_{OFF}		Room		60	200	
Charge Injection	Q	$C_L = 1\text{ nF}, V_{gen} = 6\text{ V}, R_{gen} = 0\ \Omega$	Room		2		pC
Power Supplies							
Positive Supply Current	I_+	$V_+ = 13.2\text{ V}, V_{IN} = 0\text{ or }5\text{ V}$	Room Full		0.001	1 5	μA
Negative Supply Current	I_-	$V_{IN} = 0\text{ or }5\text{ V}$	Room Full	-1 -5	-0.0001		
Logic Supply Current	I_L	$V_L = 5.25\text{ V}, V_{IN} = 0\text{ or }5\text{ V}$	Room Full		0.001	1 5	
Ground Current	I_{GND}	$V_{IN} = 0\text{ or }5\text{ V}$	Room Full	-1 -5	-0.001		

Notes:

- Room = 25°C, Full = as determined by the operating temperature suffix.
- The algebraic convention whereby the most negative value is a minimum and the most positive a maximum, is used in this data sheet.
- Typical values are for DESIGN AID ONLY, not guaranteed nor subject to production testing.
- Guaranteed by design, not subject to production test.
- V_{IN} = input voltage to perform proper function.



TYPICAL CHARACTERISTICS (25°C UNLESS NOTED)

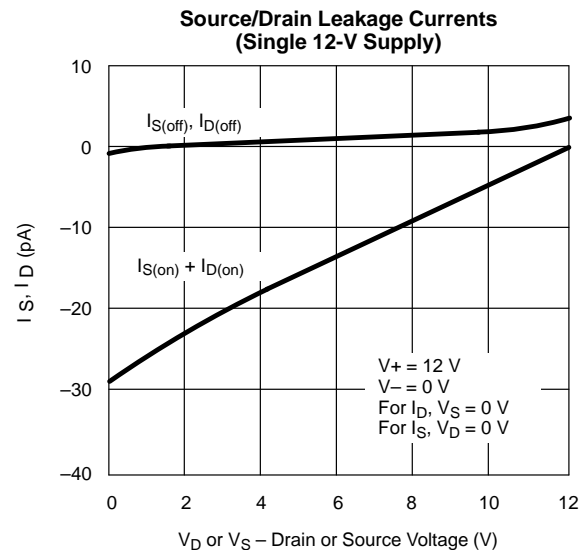
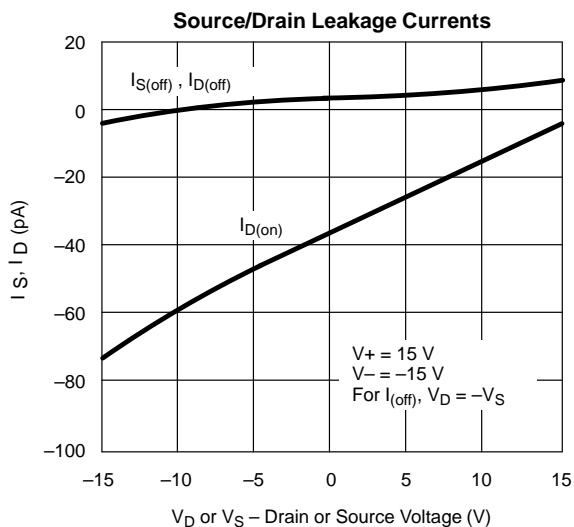
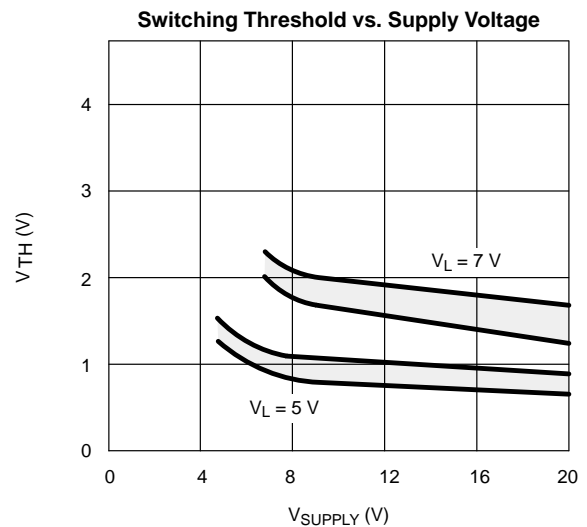
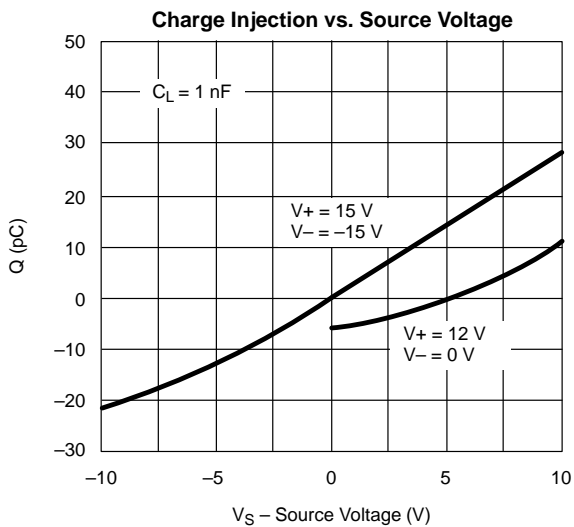
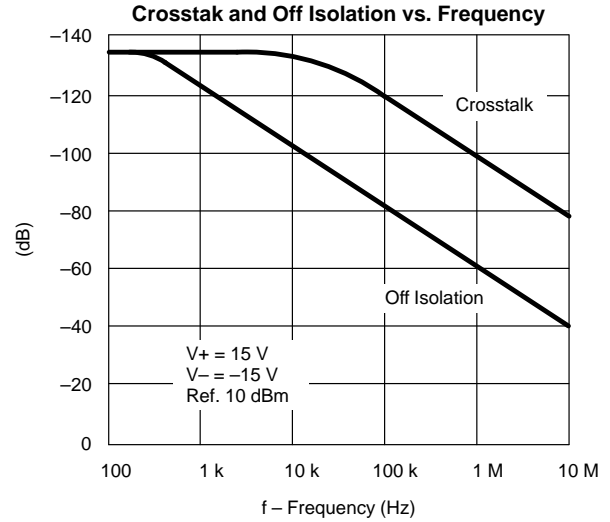
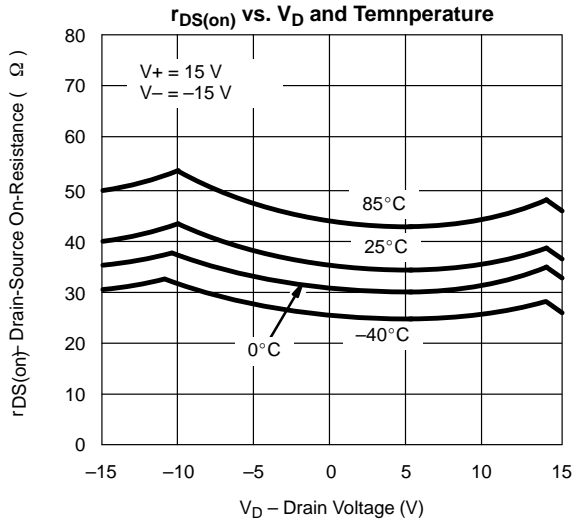

TYPICAL CHARACTERISTICS (25°C UNLESS NOTED)

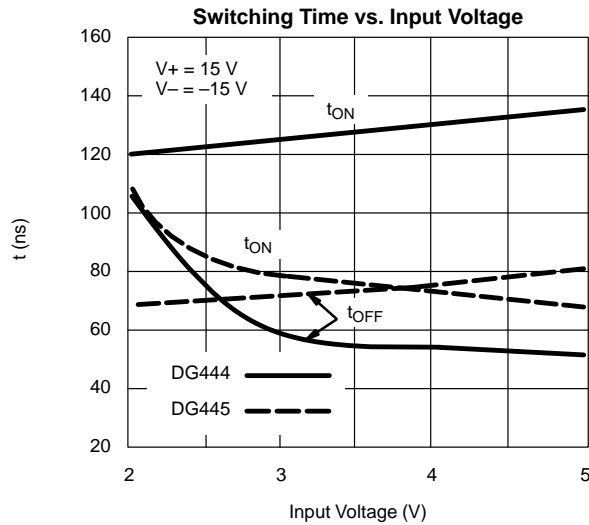
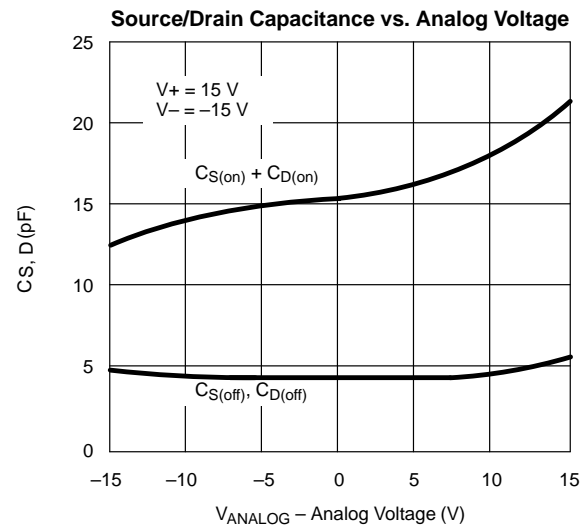
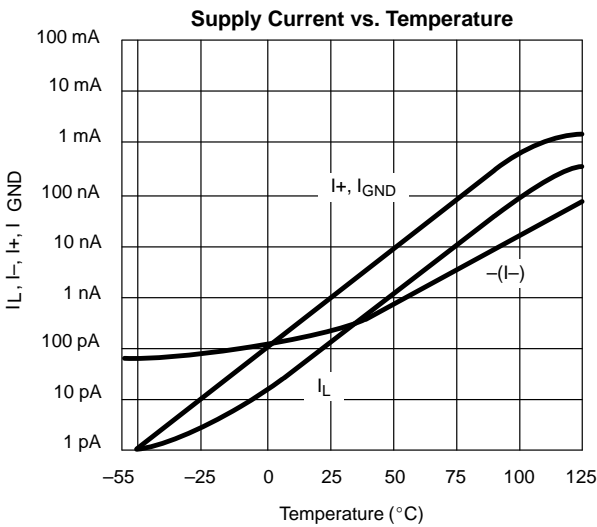
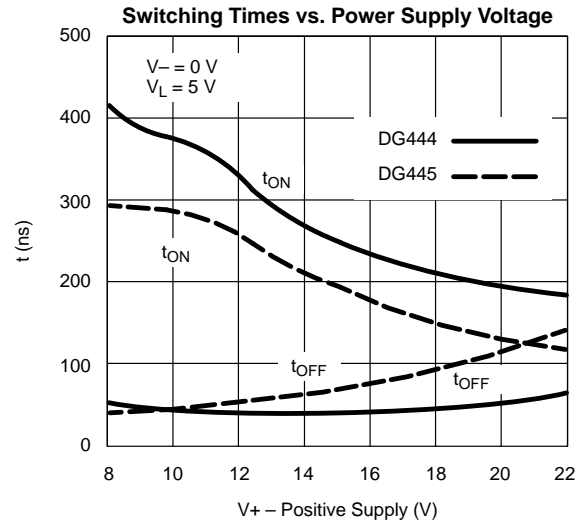
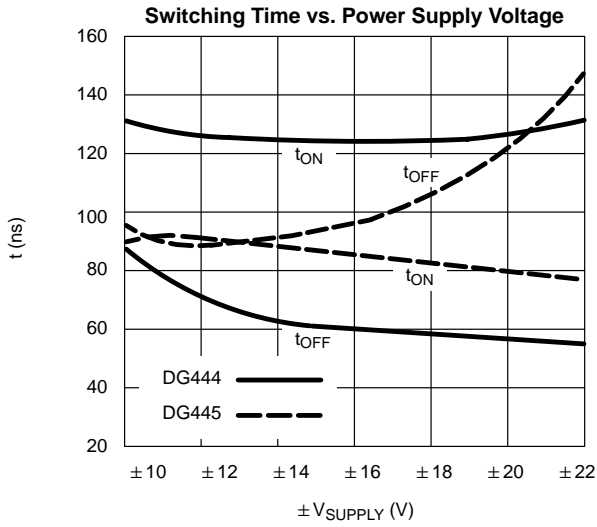

SCHEMATIC DIAGRAM (TYPICAL CHANNEL)

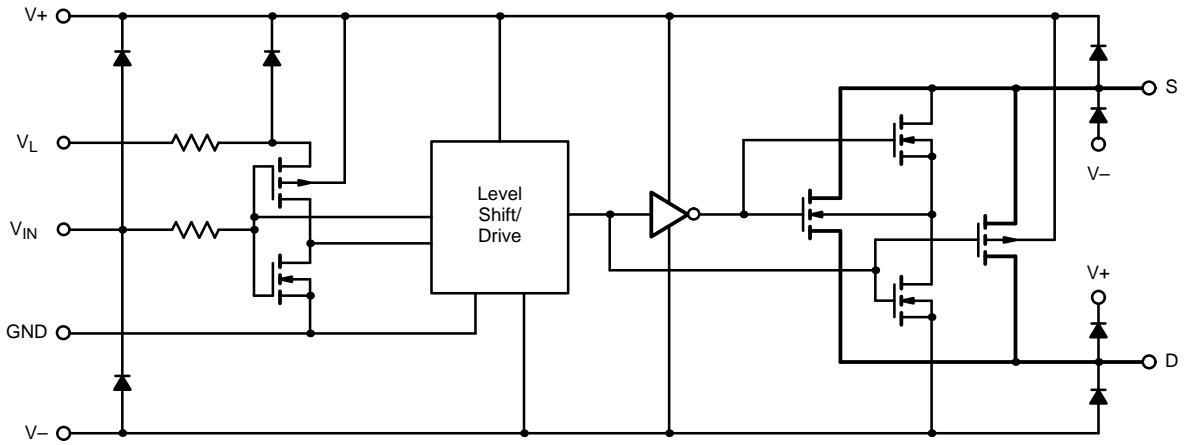
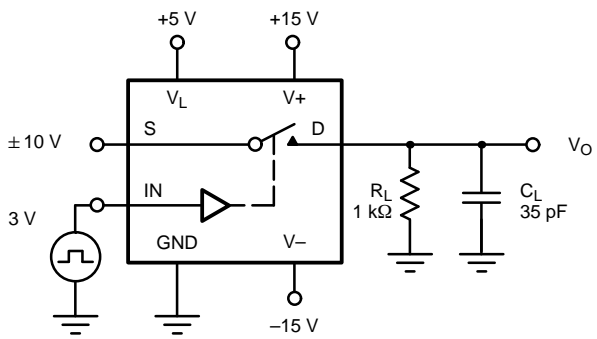
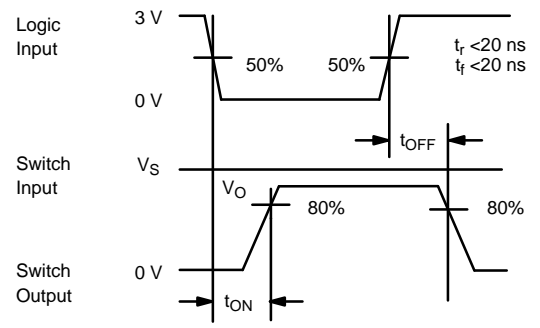

FIGURE 1.

TEST CIRCUITS



C_L (includes fixture and stray capacitance)



Note: Logic input waveform is inverted for DG445.

FIGURE 2. Switching Time

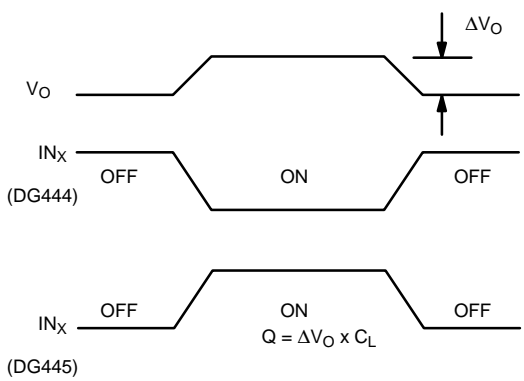
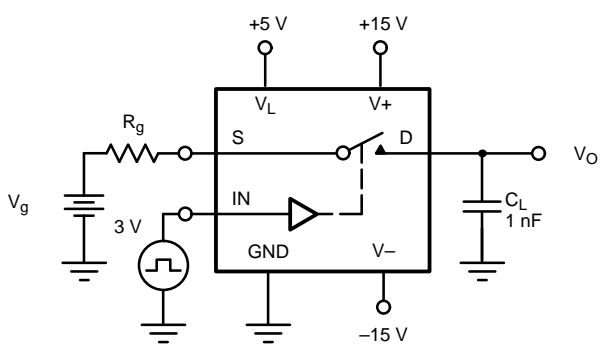

FIGURE 3. Charge Injection

TEST CIRCUITS

C = 1 mF tantalum in parallel with 0.01 mF ceramic

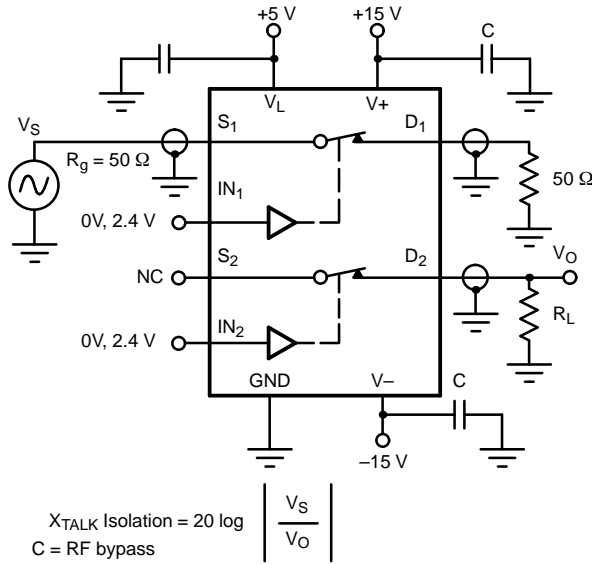

FIGURE 4. Crosstalk

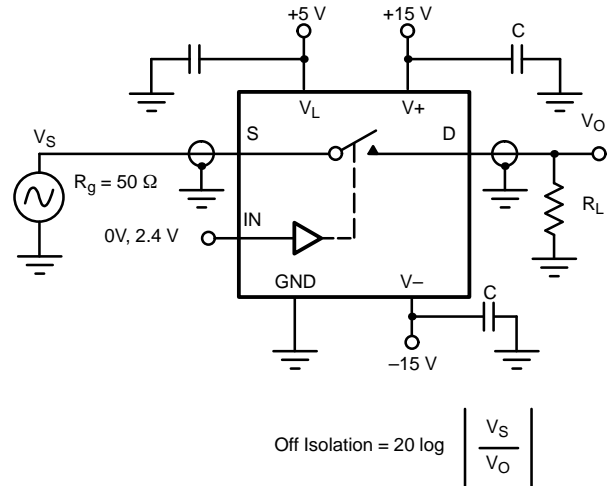

FIGURE 5. Off Isolation

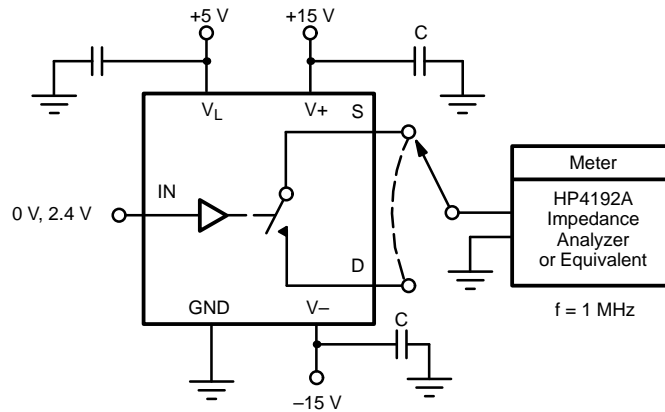

FIGURE 6. Source/Drain Capacitances

APPLICATIONS

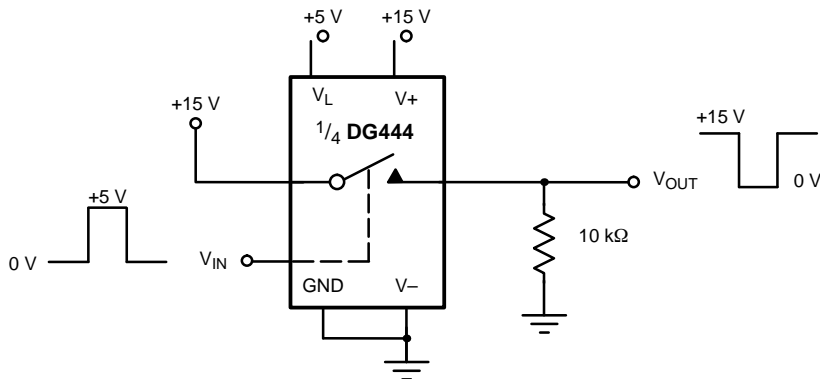

FIGURE 7. Level Shifter

APPLICATIONS

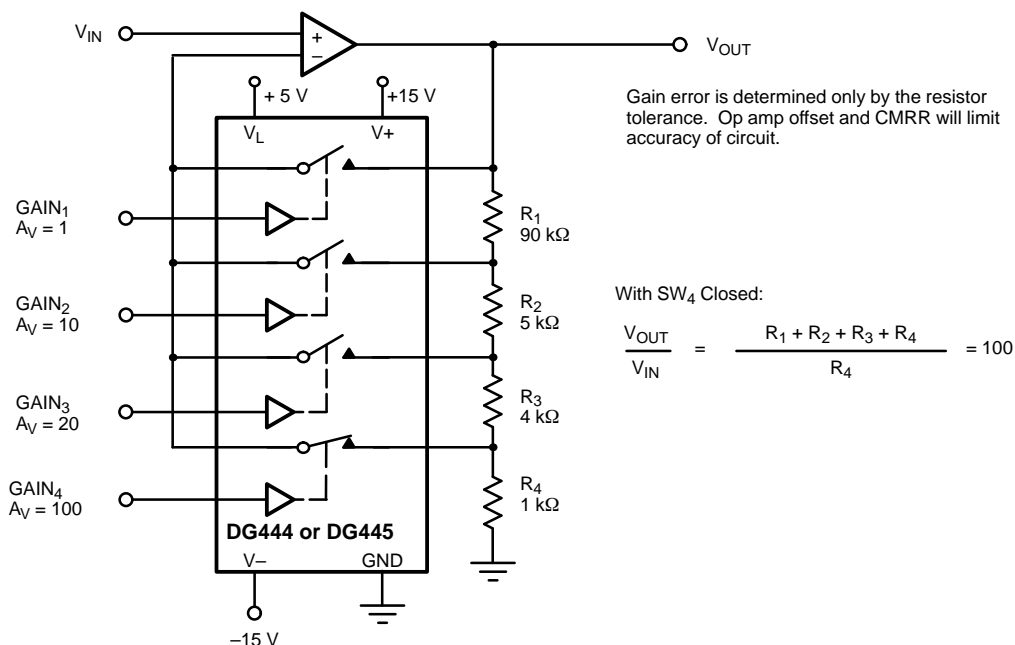

FIGURE 8. Precision-Weighted Resistor Programmable-Gain Amplifier

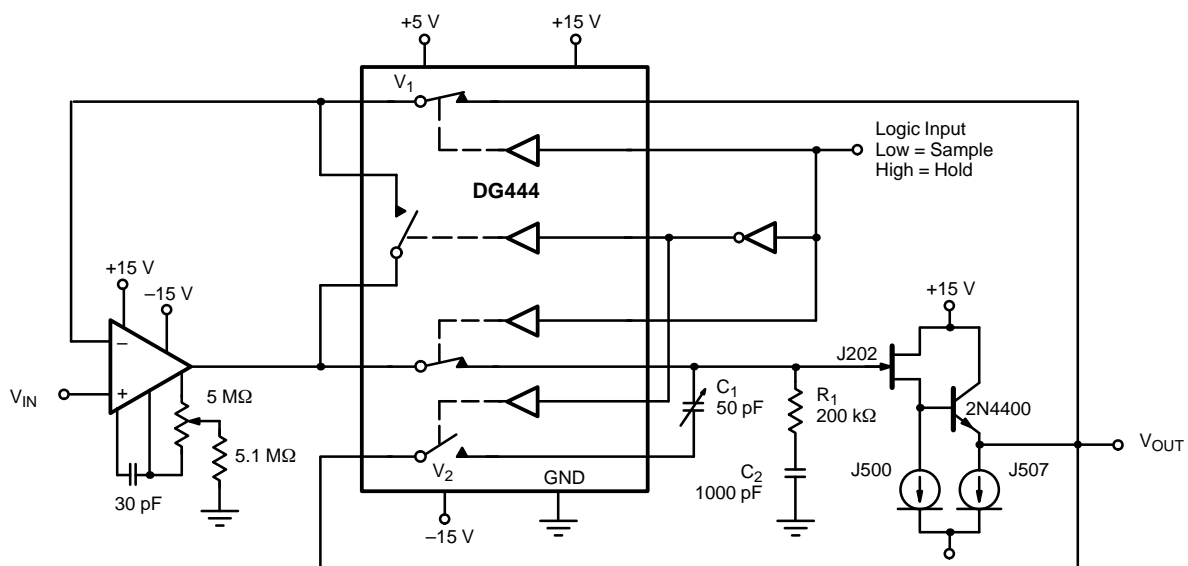

FIGURE 9. Precision Sample-and-Hold



Notice

Specifications of the products displayed herein are subject to change without notice. Vishay Intertechnology, Inc., or anyone on its behalf, assumes no responsibility or liability for any errors or inaccuracies.

Information contained herein is intended to provide a product description only. No license, express or implied, by estoppel or otherwise, to any intellectual property rights is granted by this document. Except as provided in Vishay's terms and conditions of sale for such products, Vishay assumes no liability whatsoever, and disclaims any express or implied warranty, relating to sale and/or use of Vishay products including liability or warranties relating to fitness for a particular purpose, merchantability, or infringement of any patent, copyright, or other intellectual property right.

The products shown herein are not designed for use in medical, life-saving, or life-sustaining applications. Customers using or selling these products for use in such applications do so at their own risk and agree to fully indemnify Vishay for any damages resulting from such improper use or sale.