

Wideband/Video “T” Switches

Features

- Wide Bandwidth: 500 MHz
- Low Crosstalk: -85 dB
- High Off-Isolation: -80 dB @ 5 MHz
- “T” Switch Configuration
- TTL Logic Compatible
- Fast Switching— t_{ON} : 45 ns
- Low $r_{DS(on)}$: 30 Ω

Benefits

- Flat Frequency Response
- High Color Fidelity
- Low Insertion Loss
- Improved System Performance
- Reduced Board Space
- Reduced Power Consumption
- Improved Data Throughput

Applications

- RF and Video Switching
- RGB Switching
- Local and Wide Area Networks
- Video Routing
- Fast Data Acquisition
- ATE
- Radar/FLR Systems
- Video Multiplexing

Description

The DG540/541/542 are high performance monolithic wideband/video switches designed for switching RF, video and digital signals. By utilizing a “T” switch configuration on each channel, these devices achieve exceptionally low crosstalk and high off-isolation. The crosstalk and off-isolation of the DG540 are further improved by the introduction of extra GND pins between signal pins.

To achieve TTL compatibility, low channel capacitances and fast switching times, the DG540 family is built on the Siliconix proprietary D/CMOS process. Each switch conducts equally well in both directions when on.

Functional Block Diagrams and Pin Configurations

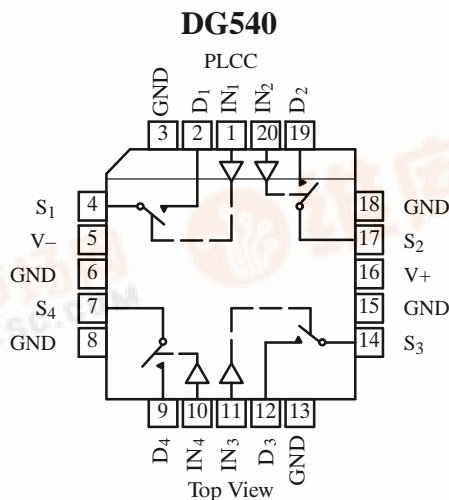
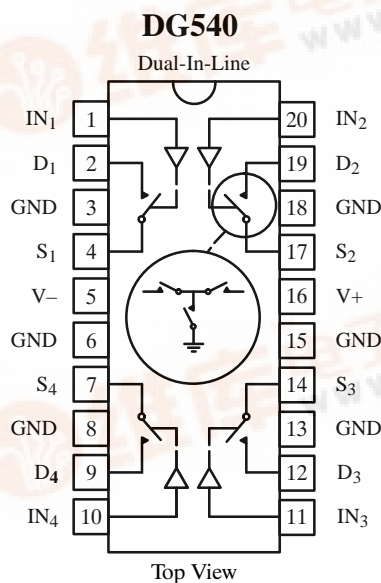

Truth Table

| Logic | Switch |
|-------|--------|
| 0 | OFF |
| 1 | ON |

Logic “0” ≤ 0.8 V
Logic “1” ≥ 2 V

Functional Block Diagrams and Pin Configurations (Cont'd)

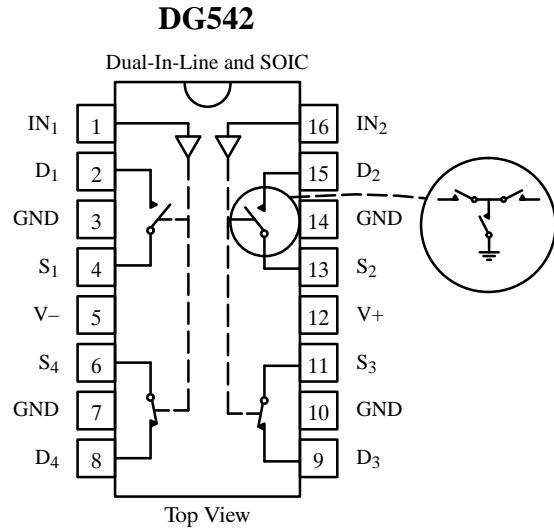
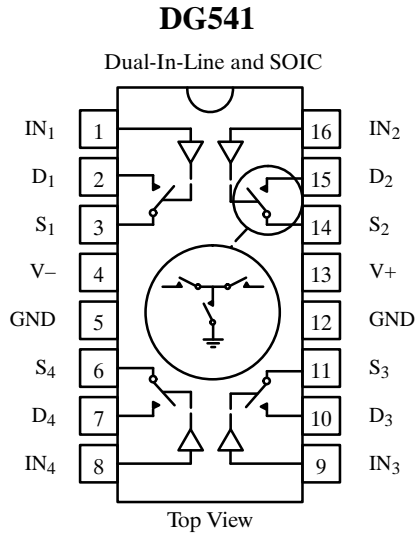

Truth Table – DG541

| Logic | Switch |
|-------|--------|
| 0 | OFF |
| 1 | ON |

Logic "0" ≤ 0.8 V
Logic "1" ≥ 2 V

Truth Table – DG542

| Logic | SW ₁ , SW ₂ | SW ₃ , SW ₄ |
|-------|-----------------------------------|-----------------------------------|
| 0 | OFF | ON |
| 1 | ON | OFF |

Logic "0" ≤ 0.8 V
Logic "1" ≥ 2 V

Ordering Information

| Temp Range | Package | Part Number |
|--------------|--------------------|-------------|
| DG540 | | |
| -40 to 85°C | 20-Pin Plastic DIP | DG540DJ |
| | 20-Pin PLCC | DG540DN |
| -55 to 125°C | 20-Pin Sidebrazed | DG540AP |
| | | DG540AP/883 |
| DG541 | | |
| -40 to 85°C | 16-Pin Plastic DIP | DG541DJ |
| | 16-Pin Narrow SOIC | DG541DY |
| -55 to 125°C | 16-Pin Sidebrazed | DG541AP |
| | | DG541AP/883 |
| DG542 | | |
| -40 to 85°C | 16-Pin Plastic DIP | DG542DJ |
| | 16-Pin Narrow SOIC | DG542DY |
| -55 to 125°C | 16-Pin Sidebrazed | DG542AP |
| | | DG542AP/883 |

Absolute Maximum Ratings

| | | | |
|---|--|--|--------|
| V+ to V- | -0.3 V to 21 V | Power Dissipation (Package) ^a | |
| V+ to GND | -0.3 V to 21 V | 16-Pin Plastic DIP ^b | 470 mW |
| V- to GND | -19 V to +0.3 V | 20-Pin Plastic DIP ^c | 800 mW |
| Digital Inputs | (V-) -0.3 V to (V+) +0.3 V or 20 mA, whichever occurs first | 16-Pin Narrow Body SOIC ^d | 640 mW |
| V _S , V _D | (V-) -0.3 V to (V-) +14 V or 20 mA, whichever occurs first | 20-Pin PLCC ^d | 800 mW |
| Continuous Current (Any Terminal) | 20 mA | 16-, 20-Pin Sidebraze DIP ^e | 900 mW |
| Current, S or D (Pulsed 1 ms, 10% duty cycle max) | 40 mA | | |
| Storage Temperature (AP Suffix) | -65 to 150°C | | |
| Storage Temperature (DJ, DN, DY Suffixes) | -65 to 125°C | | |

- Notes:
- All leads welded or soldered to PC Board.
 - Derate 6.5 mW/°C above 25°C
 - Derate 7 mW/°C above 25°C
 - Derate 10 mW/°C above 75°C
 - Derate 12 mW/°C above 75°C

Schematic Diagram (Typical Channel)

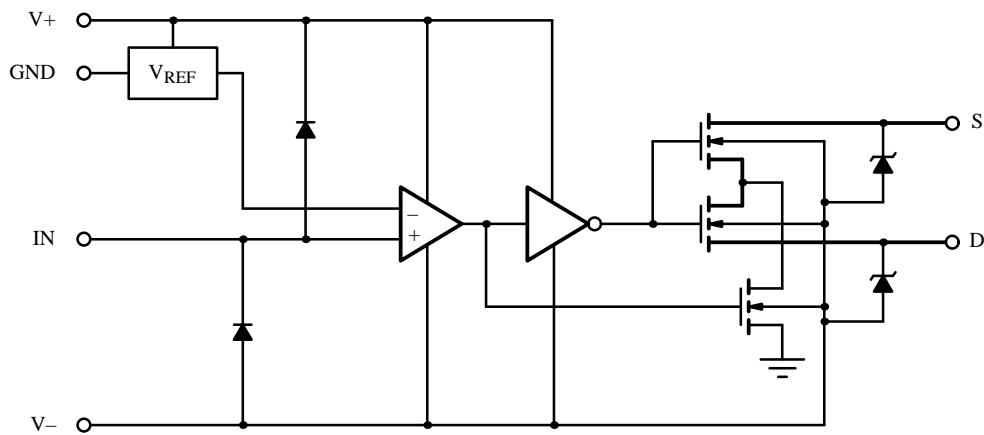

Figure 1.

DG540/541/542

Specifications^a

| Parameter | Symbol | Test Conditions Unless Specified $V_+ = 15\text{ V}$, $V_- = -3\text{ V}$ $V_{INH} = 2\text{ V}$, $V_{INL} = 0.8\text{ V}^f$ | Temp ^b | Typ ^c | A Suffix -55 to 125°C | | D Suffixes -40 to 85°C | | Unit | |
|---|---------------------|---|-------------------|------------------|--------------------------|------------------|---------------------------|------------------|---------------|----|
| | | | | | Min ^d | Max ^d | Min ^d | Max ^d | | |
| Analog Switch | | | | | | | | | | |
| Analog Signal Range | V_{ANALOG} | $V_- = -5\text{ V}$, $V_+ = 12\text{ V}$ | Full | | -5 | 5 | -5 | 5 | V | |
| Drain-Source On-Resistance | $r_{DS(on)}$ | $I_S = -10\text{ mA}$, $V_D = 0\text{ V}$ | Room | 30 | | 60 | | 60 | Ω | |
| $r_{DS(on)}$ Match | $\Delta r_{DS(on)}$ | | Full | | | 100 | | 75 | | |
| | | | Room | 2 | | 6 | | 6 | | |
| Source Off Leakage Current | $I_{S(off)}$ | $V_S = 0\text{ V}$, $V_D = 10\text{ V}$ | Room | -0.05 | -10 | 10 | -10 | 10 | nA | |
| Drain Off Leakage Current | $I_{D(off)}$ | $V_S = 10\text{ V}$, $V_D = 0\text{ V}$ | Full | | -500 | 500 | -100 | 100 | | |
| Channel On Leakage Current | $I_{D(on)}$ | $V_S = V_D = 0\text{ V}$ | Room | -0.05 | -10 | 10 | -10 | 10 | | |
| | | | Full | | -1000 | 1000 | -100 | 100 | | |
| Digital Control | | | | | | | | | | |
| Input Voltage High | V_{INH} | | Full | | 2 | | 2 | | V | |
| Input Voltage Low | V_{INL} | | Full | | | 0.8 | | 0.8 | | |
| Input Current | I_{IN} | $V_{IN} = \text{GND or } V_+$ | Room | 0.05 | -1 | 1 | -1 | 1 | μA | |
| | | | Full | | -20 | 20 | -20 | 20 | | |
| Dynamic Characteristics | | | | | | | | | | |
| On State Input Capacitance ^e | $C_{S(on)}$ | $V_S = V_D = 0\text{ V}$ | Room | 14 | | 20 | | 20 | pF | |
| Off State Input Capacitance ^e | $C_{S(off)}$ | $V_S = 0\text{ V}$ | Room | 2 | | 4 | | 4 | | |
| Off State Output Capacitance ^e | $C_{D(off)}$ | $V_D = 0\text{ V}$ | Room | 2 | | 4 | | 4 | | |
| Bandwidth | BW | $R_L = 50\ \Omega$, See Figure 5 | Room | 500 | | | | | MHz | |
| Turn On Time | t_{ON} | $R_L = 1\text{ k}\Omega$ $C_L = 35\text{ pF}$ 50% to 90% See Figure 2 | DG540 | Room | 45 | | 70 | | 70 | ns |
| | | | DG541 | Full | | | 130 | | 130 | |
| Turn Off Time | t_{OFF} | | DG542 | Room | 55 | | 100 | | 100 | |
| | | | DG541 | Full | | | 160 | | 160 | |
| | | | DG540 | Room | 20 | | 50 | | 50 | |
| | | | DG541 | Full | | | 85 | | 85 | |
| | | DG542 | Room | 25 | | 60 | | 60 | | |
| | | DG541 | Full | | | 85 | | 85 | | |
| Charge Injection | Q | $C_L = 1000\text{ pF}$, $V_S = 0\text{ V}$ See Figure 3 | Room | -25 | | | | | pC | |
| Off Isolation | OIRR | $R_{IN} = 75\ \Omega$ $R_L = 75\ \Omega$ $f = 5\text{ MHz}$ See Figure 4 | DG540 | Room | -80 | | | | dB | |
| | | | DG541 | Room | -60 | | | | | |
| | | | DG542 | Room | -75 | | | | | |
| All Hostile Crosstalk | $X_{TALK(AH)}$ | $R_{IN} = 10\ \Omega$, $R_L = 75\ \Omega$ $f = 5\text{ MHz}$, See Figure 6 | Room | -85 | | | | | | |
| Power Supplies | | | | | | | | | | |
| Positive Supply Current | I_+ | All Channels On or Off | Room | 3.5 | | 6 | | 6 | mA | |
| Negative Supply Current | I_- | | Full | | | 9 | | 9 | | |
| | | | Room | -3.2 | -6 | | -6 | | | |
| | | | Full | | -9 | | -9 | | | |

Notes:

- Refer to PROCESS OPTION FLOWCHART.
- Room = 25°C, Full = as determined by the operating temperature suffix.
- Typical values are for DESIGN AID ONLY, not guaranteed nor subject to production testing.
- The algebraic convention whereby the most negative value is a minimum and the most positive a maximum, is used in this data sheet.
- Guaranteed by design, not subject to production test.
- V_{IN} = input voltage to perform proper function.

Typical Characteristics

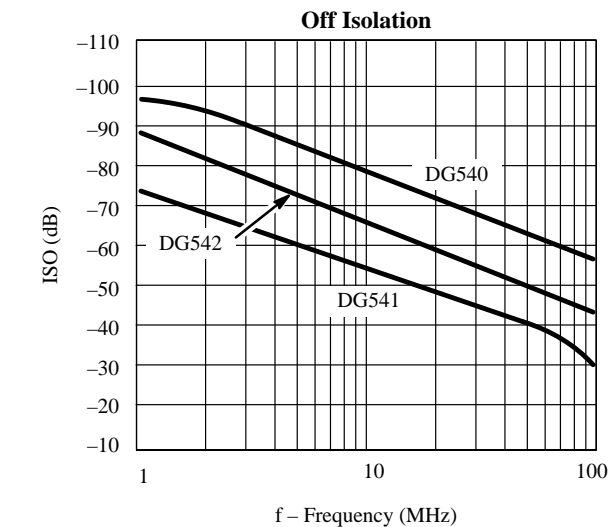
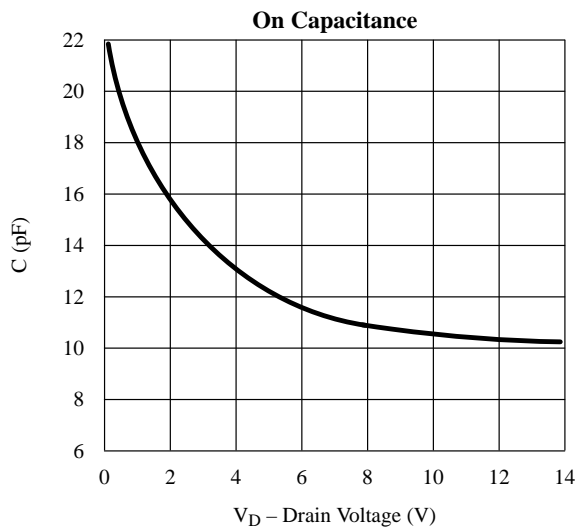
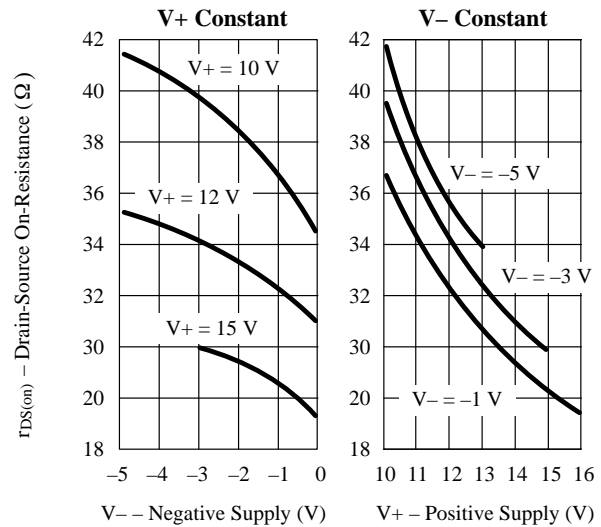
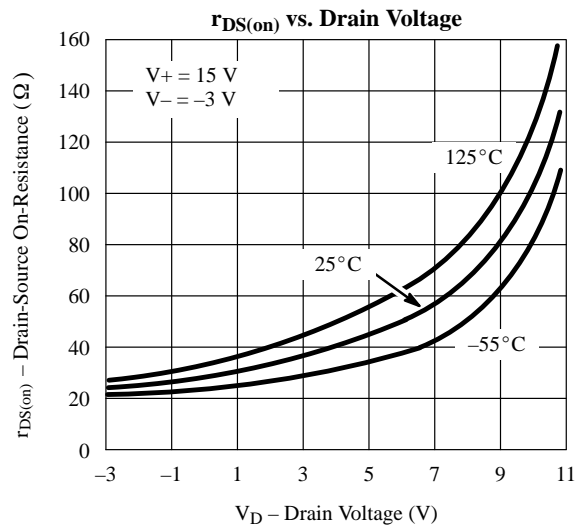
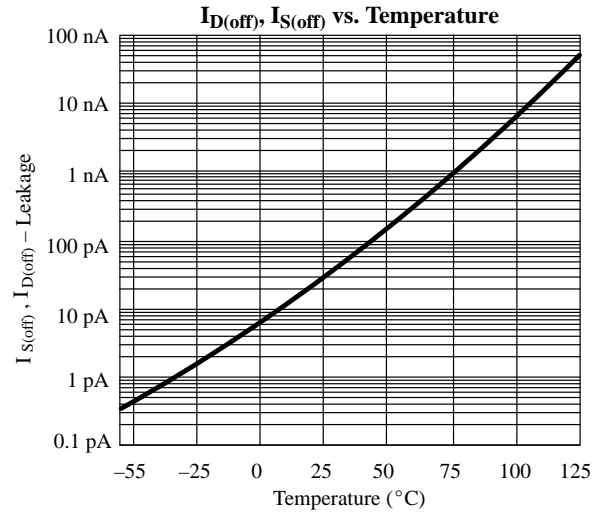
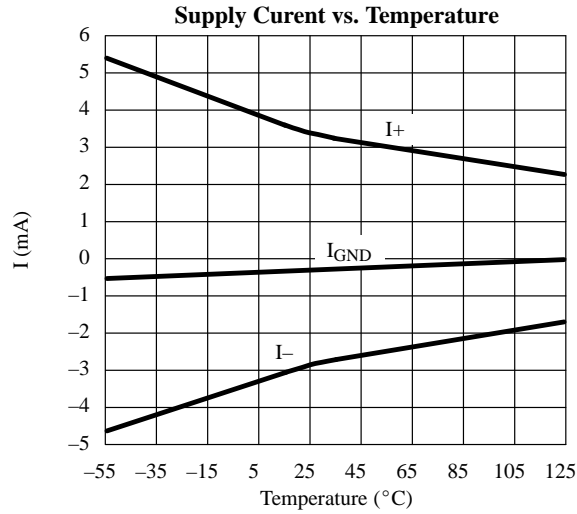

Typical Characteristics (Cont'd)

Off Isolation vs. Frequency and Load Resistance (DG540)

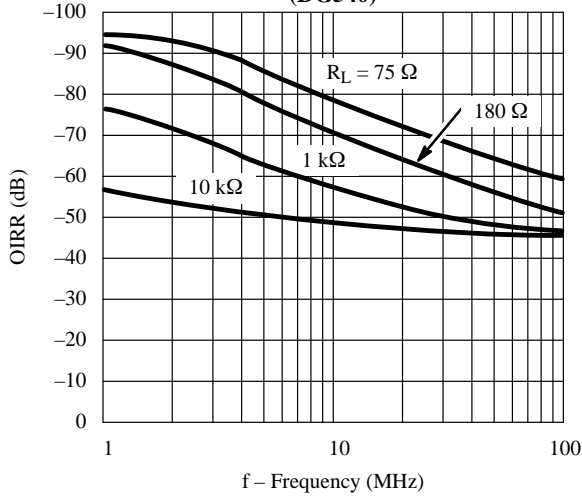

All Hostile Crosstalk

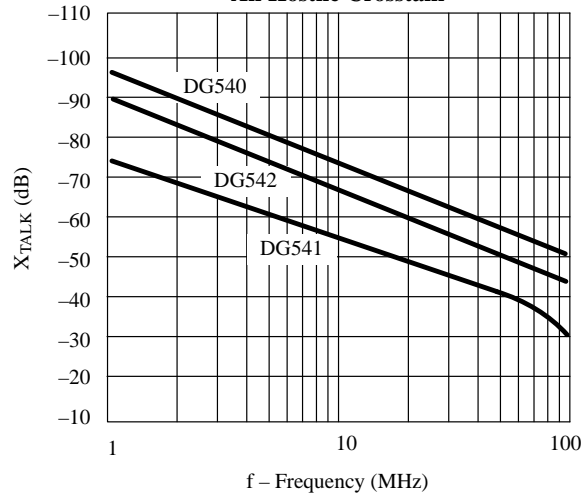

Charge Injection vs. V_S

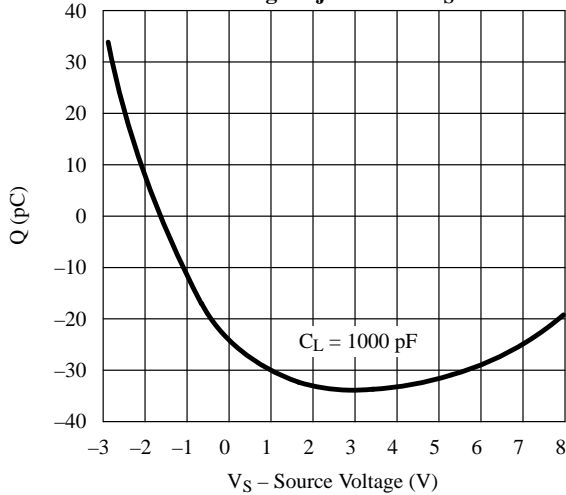

Switching Times vs. Temperature (DG540/541)

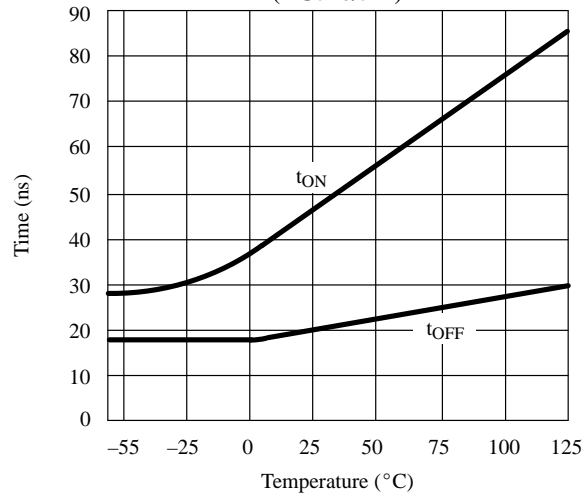

Switching and Break-Before-Make Time vs. Temperature (DG542)

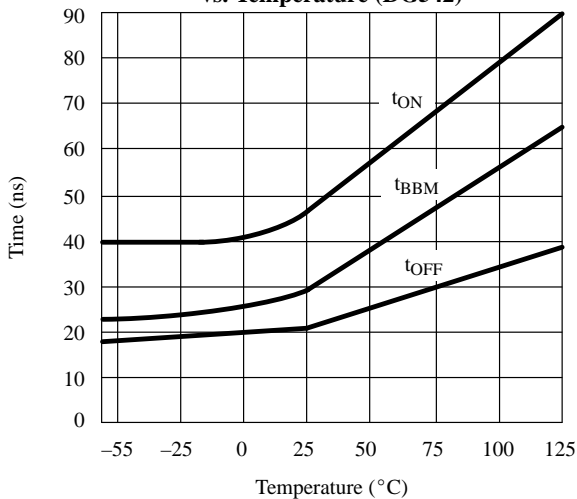

Operating Supply Voltage Range

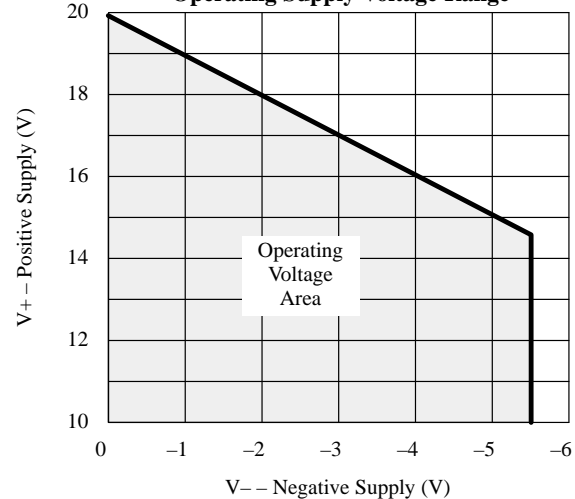

Test Circuits

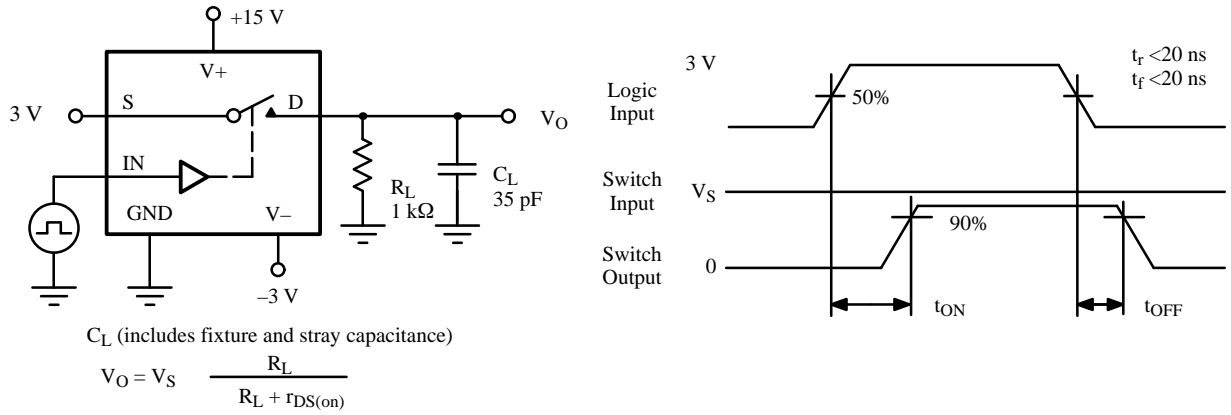

Figure 2. Switching Time

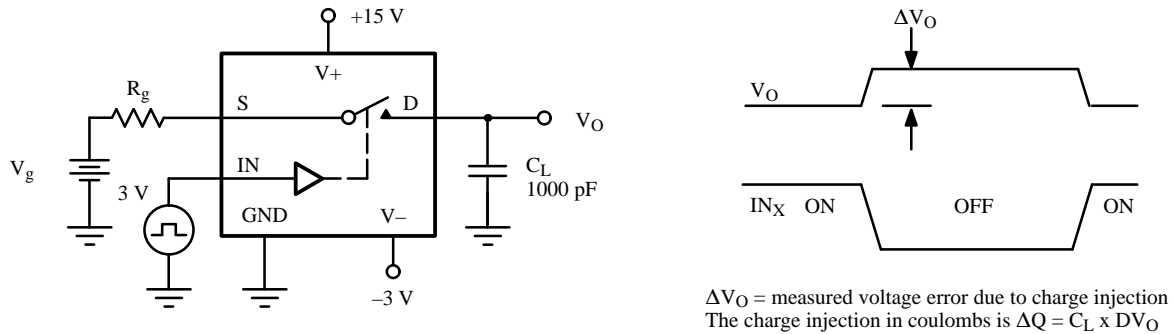

Figure 3. Charge Injection

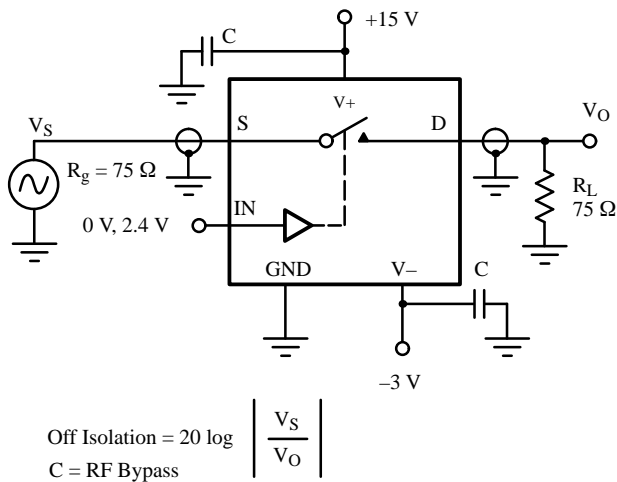

Figure 4. Off Isolation

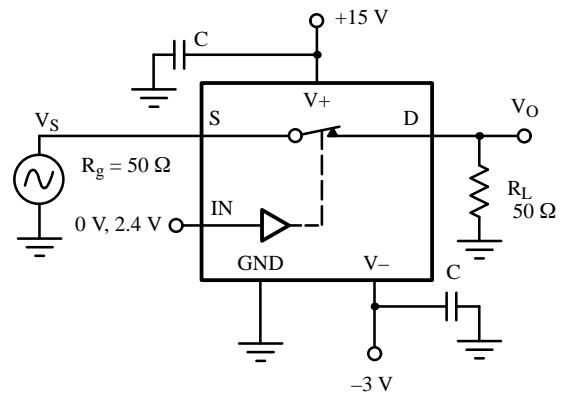

Figure 5. Bandwidth

Test Circuits (Cont'd)

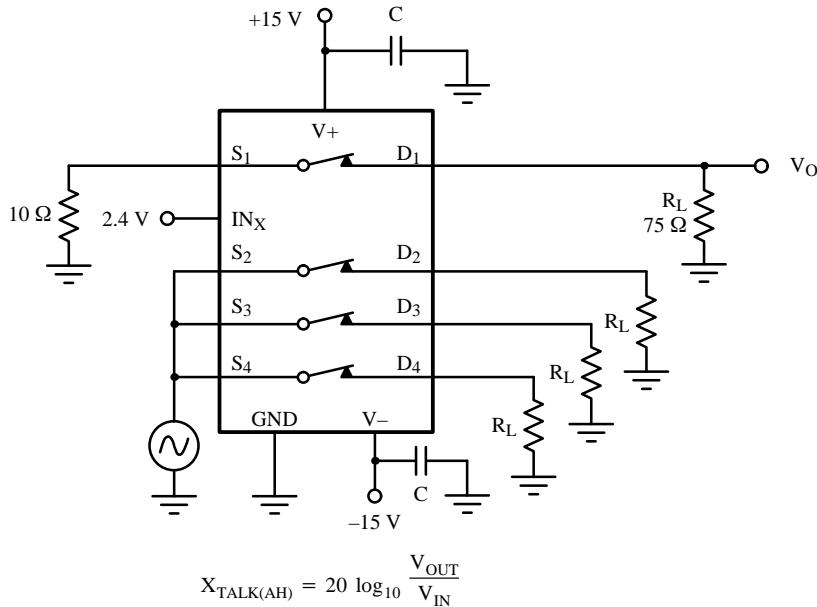

Figure 6. All Hostile Crosstalk

Applications

Device Description

The DG540/541/542 family of wideband switches offers true bidirectional switching of high frequency analog or digital signals with minimum signal crosstalk, low insertion loss, and negligible non-linearity distortion and group delay.

Built on the Siliconix D/CMOS process, these “T” switches provide excellent off-isolation with a bandwidth of around 500 MHz (350 MHz for DG541). Silicon-gate D/CMOS processing also yields fast switching speeds.

An on-chip regulator circuit maintains TTL input compatibility over the whole operating supply voltage range, easing control logic interfacing.

Circuit layout is facilitated by the interchangeability of source and drain terminals.

Frequency Response

A single switch on-channel exhibits both resistance [$r_{\text{DS(on)}}$] and capacitance [$C_{\text{S(on)}}$]. This RC combination has

an attenuation effect on the analog signal – which is frequency dependent (like an RC low-pass filter). The –3-dB bandwidth of the DG540 is typically 500 MHz (into 50 Ω). This measured figure of 500 MHz illustrates that the switch channel can not be represented by a two stage RC combination. The on capacitance of the channel is distributed along the on-resistance, and hence becomes a more complex multi stage network of R’s and C’s making up the total $r_{\text{DS(on)}}$ and $C_{\text{S(on)}}$. See Application Note AN502 for more details.

Off-Isolation and Crosstalk

Off-isolation and crosstalk are affected by the load resistance and parasitic inter-electrode capacitances. Higher off-isolation is achieved with lower values of R_L . However, low values of R_L increase insertion loss requiring gain adjustments down the line. Stray capacitances, even a fraction of 1 pF, can cause a large crosstalk increase. Good layout and ground shielding techniques can considerably improve your ac circuit performance.

Applications (Cont'd)

Power Supplies

A useful feature of the DG54X family is its power supply flexibility. It can be operated from a single positive supply (V+) if required (V- connected to ground).

Note that the analog signal must not exceed V- by more than -0.3 V to prevent forward biasing the substrate p-n junction. The use of a V- supply has a number of advantages:

1. It allows flexibility in analog signal handling, i.e., with V- = -5 V and V+ = 12 V; up to ±5-V ac signals can be controlled.
2. The value of on capacitance [$C_{S(on)}$] may be reduced. A property known as 'the body-effect' on the DMOS switch devices causes various parametric effects to occur. One of these effects is the reduction in $C_{S(on)}$ for an increasing V body-source. Note, however, that to increase V- normally requires V+ to be reduced (since V+ to V- = 21 V max.). Reduction in V+ causes an increase in $r_{DS(on)}$, hence a compromise has to be achieved. It is also useful to note that optimum video linearity performance (e.g., differential phase and gain) occurs when V- is around -3 V.
3. V- eliminates the need to bias the analog signal using potential dividers and large coupling capacitors.

$C_1 = 10 \mu\text{F}$ Tantalum
 $C_2 = 0.1 \mu\text{F}$ Ceramic

Decoupling

It is an established RF design practice to incorporate sufficient bypass capacitors in the circuit to decouple the power supplies to all active devices in the circuit. The dynamic performance of the DG54X is adversely affected by poor decoupling of power supply pins. Also, of even more significance, since the substrate of the device is connected to the negative supply, adequate decoupling of this pin is essential.

Rules:

1. Decoupling capacitors should be incorporated on all power supply pins (V+, V-). (See Figure 7.)
2. They should be mounted as close as possible to the device pins.

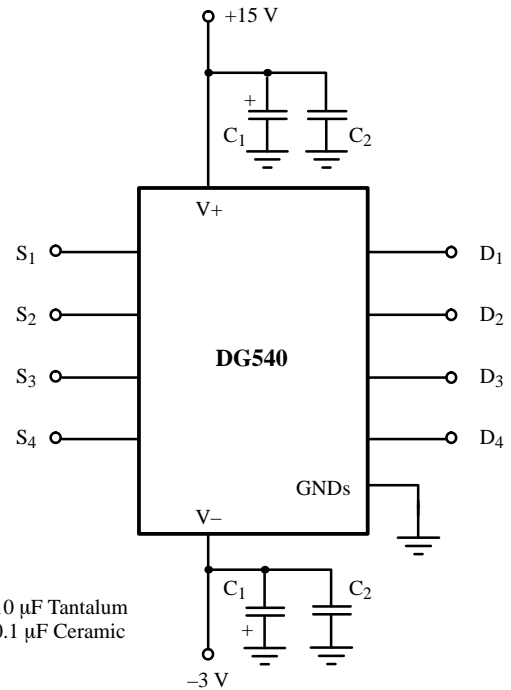

Figure 7. Supply Decoupling

Board Layout

PCB layout rules for good high frequency performance must be observed to achieve the performance boasted by the DG540. Some tips for minimizing stray effects are:

1. Use extensive ground planes on double sided PCB, separating adjacent signal paths. Multilayer PCB is even better.
2. Keep signal paths as short as practically possible, with all channel paths of near equal length.
3. Careful arrangement of ground connections is also very important. Star connected system grounds eliminate signal current flowing through ground path parasitic resistance from coupling between channels.

Applications (Cont'd)

Figure 8 shows a 4-channel video multiplexer using a DG540.

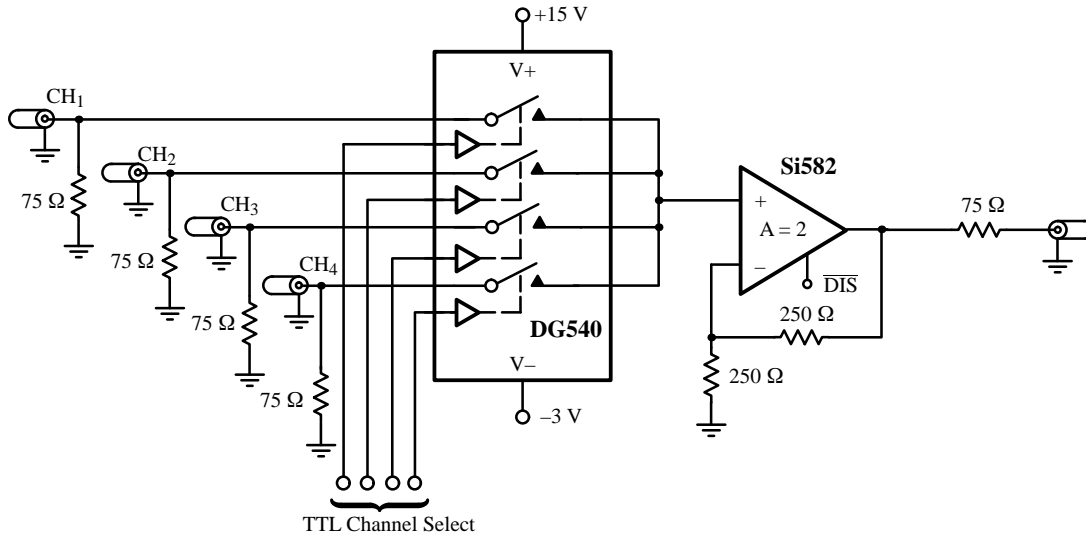

Figure 8. 4 by 1 Video Multiplexing Using the DG540

Figure 9 shows an RGB selector switch using two DG542s.

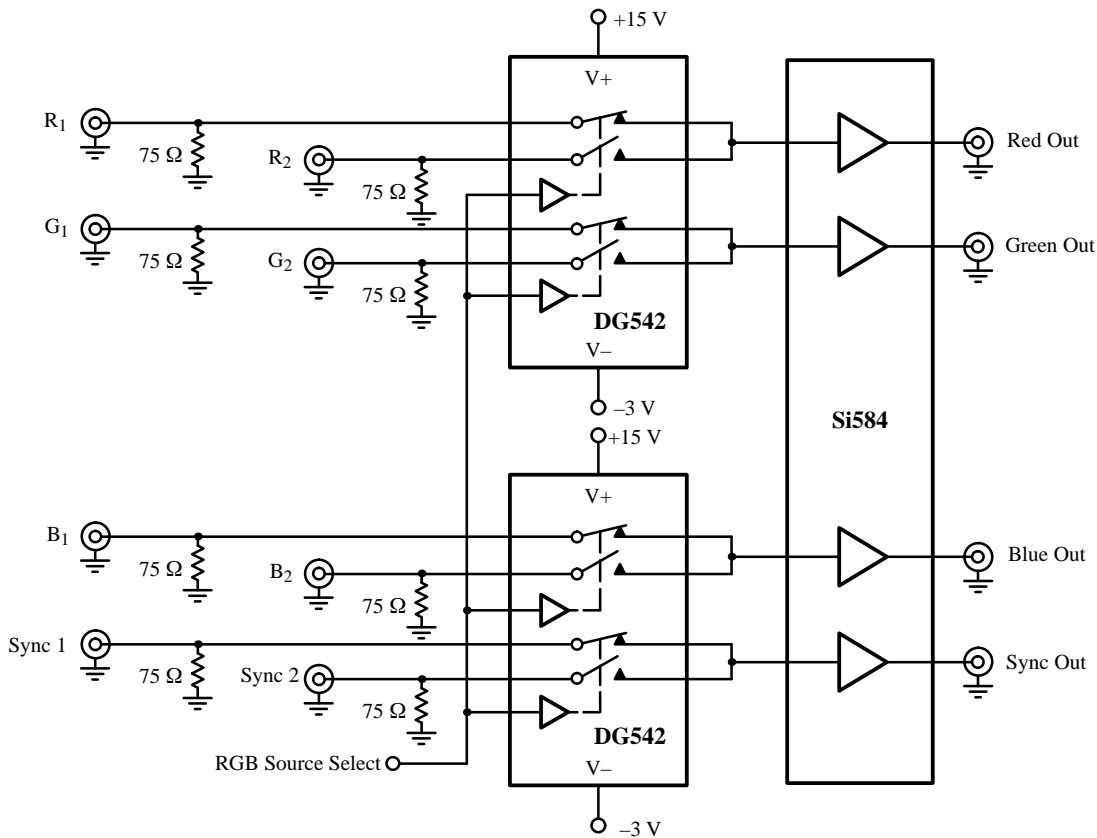

Figure 9. RGB Selector Using Two DG542s