

SK 74 DGL 063

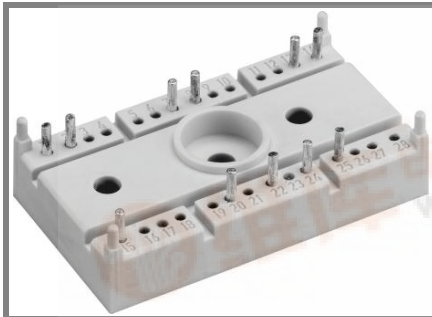

SEMITOP® 3

3-phase bridge rectifier + brake chopper

SK 74 DGL 063

Target Data

Features

- Compact design
- One screw mounting
- Heat transfer and isolation through direct copper bonded aluminum oxide ceramic (DCB)
- Ultrafast NPT technology IGBT
- CAL Technology FW

Typical Applications

- Rectifier

Absolute Maximum Ratings		$T_s = 25^\circ\text{C}$, unless otherwise specified	
Symbol	Conditions	Values	Units
IGBT - Chopper			
V_{CES}		600	V
I_C	$T_s = 25 (80)^\circ\text{C}$	45 (32)	A
I_{CM}	$T_s = 25 (80)^\circ\text{C}$, $t_p \leq 1 \text{ ms}$	90 (64)	A
V_{GES}		± 20	V
T_j		-40 ... +150	$^\circ\text{C}$
Diode - Chopper			
I_F	$T_s = 25 (80)^\circ\text{C}$	36 (24)	A
$I_{FM} = -I_{CM}$	$T_s = 25 (70)^\circ\text{C}$, $t_p \leq 1 \text{ ms}$	72 (48)	A
T_j		-40 ... +150	$^\circ\text{C}$
Rectifier			
V_{RRM}		800	V
I_{FAV} / I_{TAV}	$T_s = 80^\circ\text{C}$	29	A
I_{FSM} / I_{TSM}	$t_p = 10 \text{ ms}$, $\sin 180^\circ$, $T_j = 25^\circ\text{C}$	370	A
I_t^2	$t_p = 10 \text{ ms}$, $\sin 180^\circ$, $T_j = 25^\circ\text{C}$	685	A^2s
T_j		-40 ... +150	$^\circ\text{C}$
T_{sol}	Terminals, 10s	260	$^\circ\text{C}$
T_{stg}		-40 ... +125	$^\circ\text{C}$
V_{isol}	AC, 1 min. / 1s	2500 / 3000	V

Characteristics		$T_s = 25^\circ\text{C}$, unless otherwise specified			
Symbol	Conditions	min.	typ.	max.	Units
IGBT - Chopper					
V_{CEsat}	$I_C = 30 \text{ A}$, $T_j = 25 (125)^\circ\text{C}$		1,8 (2)	2,1 (2,3)	V
$V_{GE(th)}$	$V_{GE} = V_{CE}$, $I_C = 0,5 \text{ mA}$	3	4	5	V
$V_{CE(TO)}$	$T_j = 25^\circ\text{C} (125)^\circ\text{C}$		0,85 (0,9)		V
r_T	$T_j = ^\circ\text{C} ()^\circ\text{C}$				$\text{m}\Omega$
C_{ies}	$V_{CE} = 25 \text{ V}$, $V_{GE} = 0 \text{ V}$, $f = 1 \text{ MHz}$		2,6		nF
C_{oes}	$V_{CE} = V_{GE} = 0 \text{ V}$, $f = 1 \text{ MHz}$		-		nF
C_{res}	$V_{CE} = V_{GE} = 0 \text{ V}$, $f = 1 \text{ MHz}$		-		nF
$R_{th(j-s)}$	per IGBT			1	K/W
$t_{d(on)}$	under following conditions		45		ns
t_r	$V_{CC} = 300 \text{ V}$, $V_{GE} = \pm 15 \text{ V}$		40		ns
$t_{d(off)}$	$I_C = 30 \text{ A}$, $T_j = 125^\circ\text{C}$		250		ns
t_f	$R_{Gon} = R_{Goff} = 22 \Omega$		30		ns
E_{on}	inductive load		1,45		mJ
E_{off}			1,2		mJ
Diode - Chopper					
$V_F = V_{EC}$	$I_F = 25 \text{ A}$, $T_j = 25 (125)^\circ\text{C}$		1,45 (1,4)	1,7 (1,75)	V
$V_{(TO)}$	$T_j = ^\circ\text{C} (125)^\circ\text{C}$		(0,85)	(0,9)	V
r_T	$T_j = ^\circ\text{C} (125)^\circ\text{C}$		(22)	(16)	$\text{m}\Omega$
$R_{th(j-s)}$	per diode			1,7	K/W
I_{RRM}	under following conditions		16		A
Q_{rr}	$I_F = 25 \text{ A}$, $V_R = 300 \text{ V}$		2		μC
E_{rr}	$V_{GE} = 0 \text{ V}$, $T_j = 125^\circ\text{C}$		25		mJ
	$di_F/dt = 500 \text{ A}/\mu\text{s}$				
Diode rectifier					
V_F	$I_F = 25 \text{ A}$, $T_j = 25^\circ\text{C}$		1,25		V
$V_{(TO)}$	$T_j = 150^\circ\text{C}$		0,8		V
r_T	$T_j = 150^\circ\text{C}$		13		$\text{m}\Omega$
$R_{th(j-s)}$	per diode			1,7	K/W
Temperatur sensor					
R_{ts}	$\%$, $T_r = ()^\circ\text{C}$		()		Ω
Mechanical data					
w			30		g
M_s	Mounting torque			2,5	Nm

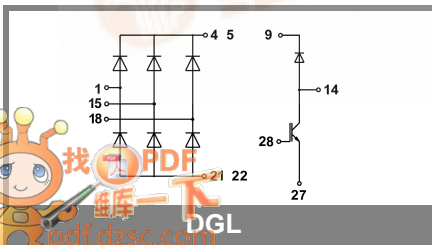

SK 74 DGL 063

Dimensions in mm

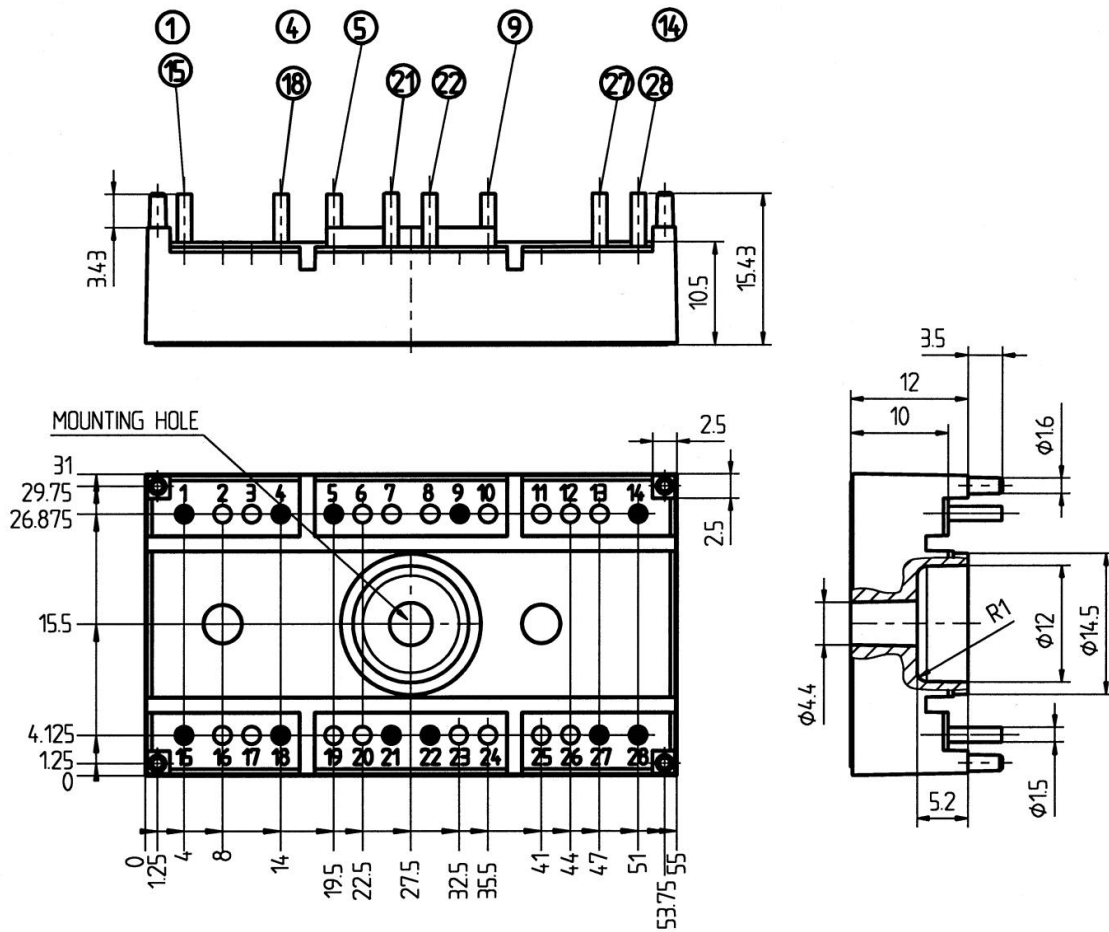

Case T 14 (Suggested hole diameter, in the PCB, for solder pins and plastic mounting pins: 2mm)

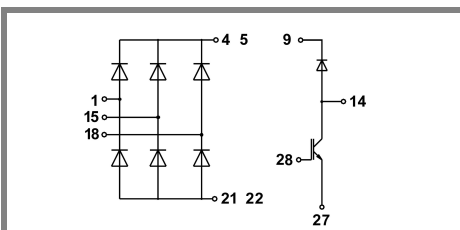

Case T 14

This is an electrostatic discharge sensitive device (ESDS), international standard IEC 60747-1, Chapter IX.

This technical information specifies semiconductor devices but promises no characteristics. No warranty or guarantee expressed or implied is made regarding delivery, performance or suitability.