

DGP30 SERIES SINGLE OUTPUT

DESCRIPTION

The single output DGP30 Series is designed to accept an extended 2:1 input voltage range for use in industrial and telecom applications. The output of the converter is electrically isolated, thereby allowing the output to be configured as a positive or negative output voltage. For additional system utility output Trim and Remote ON/OFF are featured. Overcurrent protection, overtemperature protection, and output overvoltage transient protection allow safe, reliable operation.

FEATURES

- Remote ON/OFF and TRIM
- Low OFF Current
- Overcurrent and Overtemperature Protection
- Efficiencies to 86%
- Transient Output Overvoltage Protection
- 1544V Isolation
- Five-Side Shielded Case
- Extended Range Input (2:1)

Selection Chart				
Model	Input Range VDC		Output VDC	Output mA
	Min	Max		
DGP30E48S5	36	72	5	5000
DGP30E48S12	36	72	12	2500
DGP30E48S15	36	72	15	2000

General Specifications (1)				
All Models				Units
ON/OFF Function (2)				
ON Logic Level or Pin Open	MIN	8.0	VDC	
OFF Logic Level	MAX	2.0	VDC	
Input Resistance	TYP	100	Kohms	
Converter Idle Current ON/OFF Pin Low	TYP	<1	mA	
Isolation (3)				
Isolation Voltage 10µA Leakage Input-Output	MIN	1544	VDC	
Input to Output Capacitance	TYP	300	pF	
Output Trim Function (4)				
Input Resistance	TYP	20	Kohms	
Programming Range	MIN	±10	%	
Environmental				
Case Operating Range, Tc No Derating	MIN	-40	°C	
	MAX	+90		
Storage Range	MIN	-55	°C	
	MAX	105		
Thermal Impedance (5)	TYP	10	°C/Watt	
Thermal Shutdown Case Temperature	TYP	100	°C	
General				
MTBF (Calculated)	TYP	800,000	HRS	
Unit Weight	TYP	1.9 / 54	oz / gm	
Chassis Mounting Kit	CM2A1			

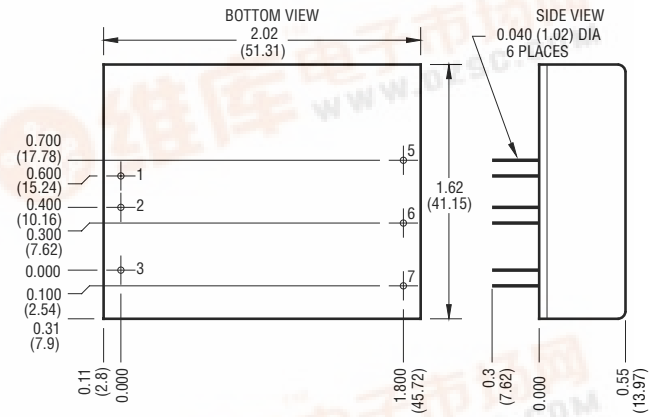

Mechanical tolerances unless otherwise noted:

X.XX dimensions: ±0.020 inches

X.XXX dimensions: ±0.005 inches

Pin	Function
1	+INPUT
2	-INPUT
3	ON/OFF
4	NO PIN
5	+OUT
6	-OUT
7	TRIM

NOTES

- (1) All parameters measured at Tc = 25°C, nominal input voltage and full rated load unless otherwise noted. Refer to the Technical Reference Section for the definition of terms, measurement circuits and other information.
- (2) ON/OFF pin is referenced to pin 2, -Input. See DGP30 Series Application Notes for the specific requirements of this feature.
- (3) The Case is electrically connected to Pin 1, +Input.
- (4) Full output trim range may not be available at minimum input voltage and full load. Full trim is guaranteed from minimum input voltage, plus 5%, and full load.
- (5) The case thermal impedance is specified as the case temperature rise over ambient per package watt dissipated.

DGP30 SERIES – SINGLE OUTPUT

Input Parameters (1)					
Model		DGP30E48S5	DGP30E48S12	DGP30E48S15	Units
Voltage Range	MIN	36.0			VDC
	TYP	48.0			
	MAX	72.0			
Input Current	Full Load	630	730	730	mA
	No Load	4	4	4	
Efficiency	TYP	84	86	86	%
Switching Frequency	TYP	200			kHz
Maximum Input Overvoltage, 100ms No Damage	MAX	85			VDC
Turn-on Time	TYP	15			ms

Output Parameters (1)					
Model		DGP30E48S5	DGP30E48S12	DGP30E48S15	Units
Output Voltage		5	12	15	VDC
Rated Load (2)	MIN	1250	625	500	mA
	MAX	5000	2500	2000	
Voltage Range 100% Load	MIN	4.95	11.90	14.90	VDC
	TYP	5.00	12.00	15.00	
	MAX	5.05	12.10	15.10	
Load Regulation Min-Max Full Load	TYP	0.5	0.2	0.2	%
	MAX	1.0	1.0	1.0	
Line Regulation Vin = Min-Max VDC	TYP	0.2			%
	MAX	1.0			
Short Term Stability (3)	TYP	<0.02			%
Long Term Stability	TYP	<0.05			%/kHrs
Input Ripple Rejection (4)	TYP	60			dB
Noise, 0-20MHz bw (5)	TYP	75	100	100	mV _{pp}
Temperature Coefficient	TYP	50			ppm/°C
	MAX	150			
Overvoltage Clamp	TYP	6.8	15	18	VDC
Short Circuit Protection to Common for all Outputs		Continuous Current Limiting and Overtemperature Shutdown			

NOTES

- (1) All parameters measured at Tc=25 °C case temperature, nominal input voltage and full rated load unless otherwise noted. Refer to the Technical Reference Section for definition of terms, measurement circuits and other information.
- (2) Minimum load required for rated regulation only. Module will not be damaged if run at less than minimum load.
- (3) Short term stability is specified after a 30 minute warm-up at full load, and with constant line, load and ambient conditions.
- (4) The input ripple rejection is specified for DC to 120Hz ripple with a modulation amplitude of 1% Vin.
- (5) Noise is measured per Technical Reference Section. Output noise is measured with a 1µF tantalum capacitor connected 1" from the output pins.

For the Most Up-To-Date Information

www.power-one.com

24 Hours/Day—7 Days/Week



NUCLEAR AND MEDICAL APPLICATIONS Power-One products are not authorized for use as critical components in life support systems, equipment used in hazardous environments, or nuclear control systems without the express written consent of the President of Power-One, Inc.

TECHNICAL REVISIONS The appearance of products, including safety agency certifications pictured on labels, may change depending on the date manufactured. Specifications are subject to change without notice.

DGP30 SERIES – SINGLE OUTPUT

DGP30 SERIES APPLICATION NOTES:

External Capacitance Requirements

No external capacitance is required for operation of the DGP30 Series. However, it is recommended that the DGP30 Series use a capacitor of sufficient ripple current capacity connected across the input pins if a capacitive input source is farther than 1" from the converter. To meet the reflected ripple requirements of the converter, an input impedance of less than 0.05 Ohms from DC to 200KHz is required. External output capacitance is not required for operation, however it is recommended that 1µF to 10µF of tantalum and 0.001 to 0.1µF ceramic capacitance be selected for reduced system noise. Additional output capacitance may be added for increased filtering, but should not exceed 400µF.

Negative Outputs

A negative output voltage may be obtained by connecting the +OUT to circuit ground and connecting -OUT as the negative output.

Remote ON/OFF Operation

The remote ON/OFF pin may be left floating if this function is not used. It is recommended to drive this pin with an open collector arrangement or a relay contact. When the ON/OFF pin is pulled low with respect to the -INPUT, the converter is placed in a low power drain state. Since the ON/OFF pin is driven by a 9 volt internal source via a 100KΩ resistor, the pin should not be driven by TTL logic. Attempts to drive this circuit with logic circuits may result in damage to user circuitry.

Output TRIM

The TRIM pin may be used to adjust the output ±5% from the nominal setting. This function allows adjustment for voltage drops in the system wiring, as well 5.2 volt outputs for ECL applications. Figure 1 shows the proper connections to use this function. A trimpot value of 10KΩ should be used for the 5 volt output. A trimpot value of 20KΩ should be used for 12 and 15 volt outputs. If the TRIM function is not required the pin may be left floating.

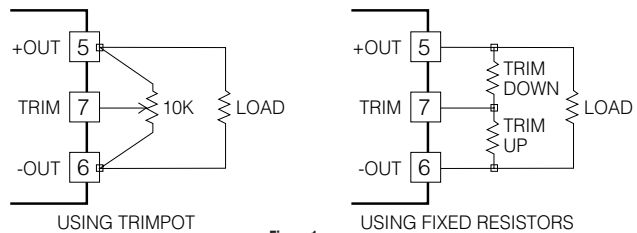
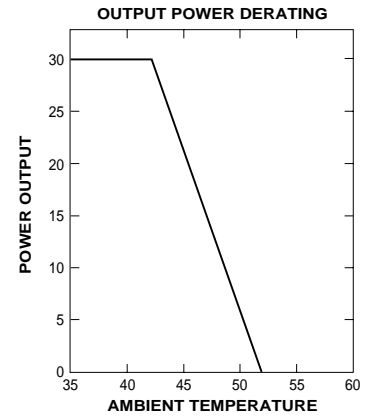
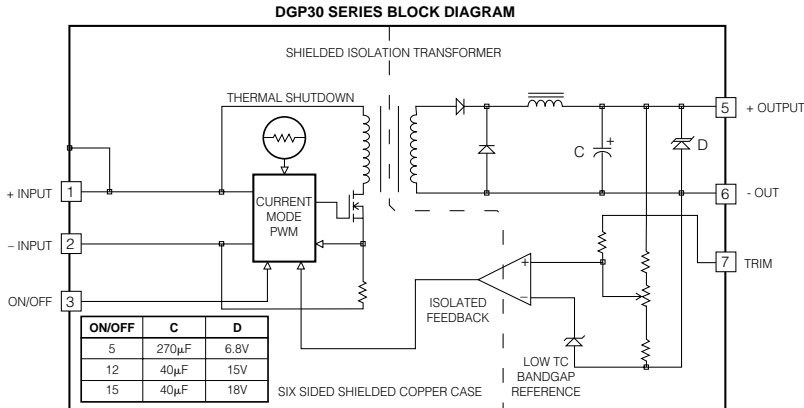

Figure 1.



DGP30 SERIES – SINGLE OUTPUT



Typical Performance: (Tc=25°C, Vin=Nom VDC, Rated Load)

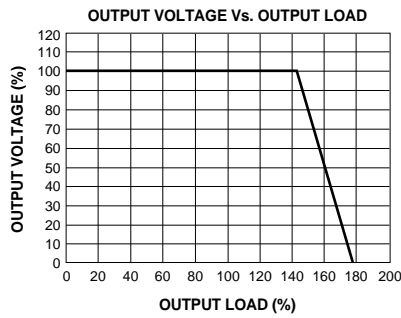
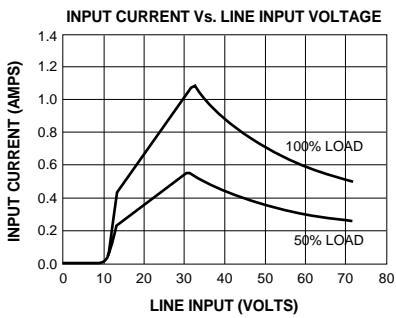
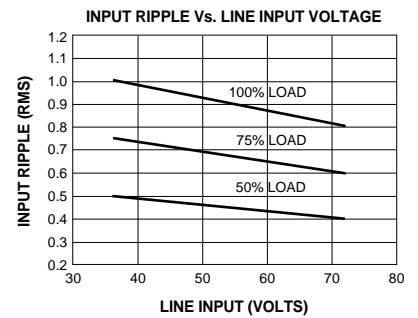
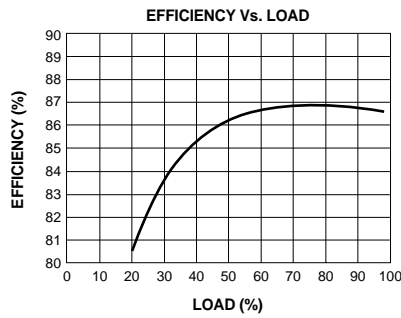
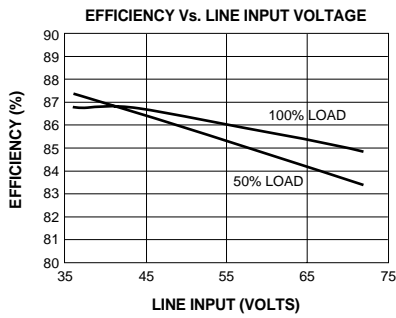

For the Most Up-To-Date Information

www.power-one.com

24 Hours/Day—7 Days/Week