

# DMD 5602

**10CH SELECTOR  
FOR CORDLESSPHONE**

The DMD5602 channel selector is a CMOS integrated circuit designed specifically to select 10 channels used in 46/49MHz cordless phones. This device has programmable counter, reference frequency generator, ROM for the transmit and receive loop, and phase detector

FEATURES

- 10channel selection with 4-Bit data input
- On-chip oscillator with external crystal (10.24MHz)
- Lock detect signal
- Standby Operation for power savings
- Operating Voltage range : 2.5V~5.5V
- Maximum operating frequency : 60MHz, Vin=200mV<sub>p-p</sub>

MAXIMUM RATINGS(Ta=25℃)

CHARACTERISTIC	SYMBOL	RATING	UNIT
Supply Voltage	V <sub>DD</sub>	-0.5~6.0	V
Input Voltage ( All Inputs)	V <sub>IN</sub>	~0.3~V <sub>DD</sub> +0.5	V
Output Current (LDN)	I <sub>out</sub>	0~3.0	mA
Power Dissipation (V <sub>DD</sub> =5V)	P <sub>D</sub>	27	mw
Operating Temperature	T <sub>our</sub>	-30~+75	℃
Storage Temperature	T <sub>stg</sub>	-65~+150	℃

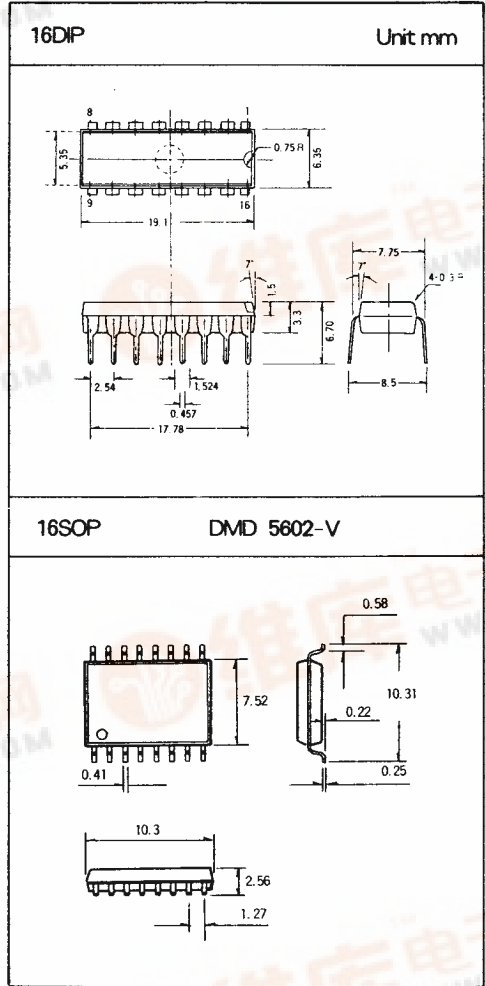

# DMD 5602

## □ BLOCK DIAGRAM

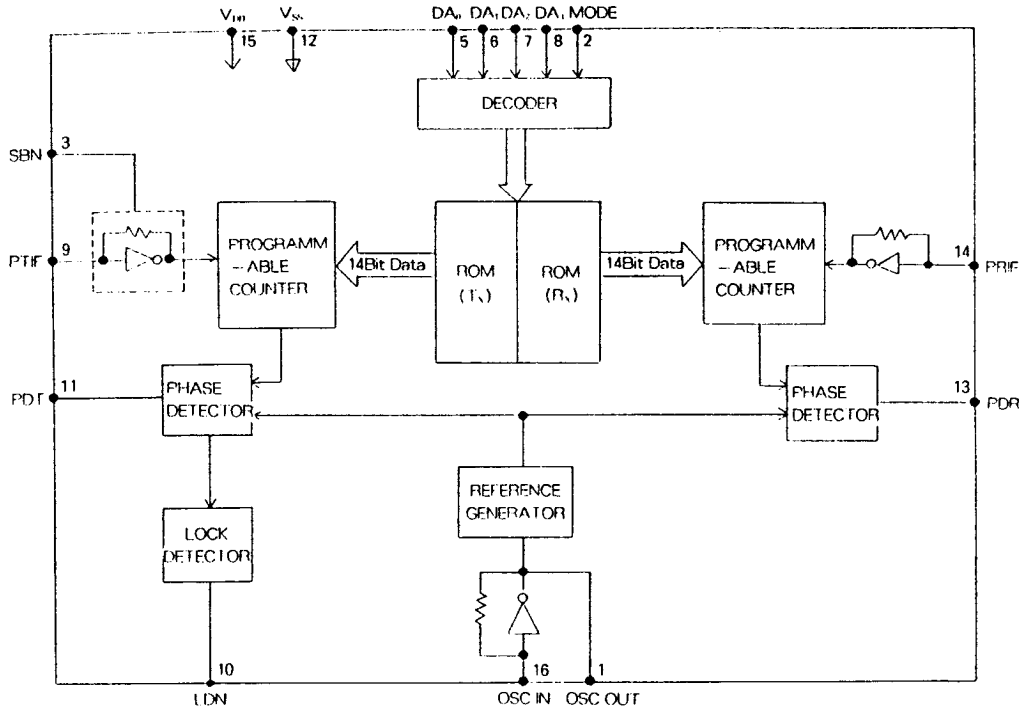

## □ PIN CONFIGURATION

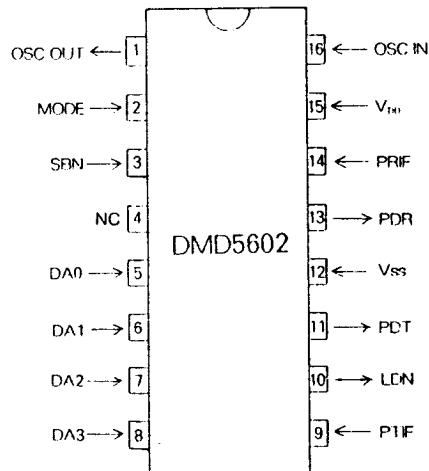

# DMD 5602

PIN DESCRIPTION

PIN		I/O	DESCRIPTION
NAME	NO		
OSC IN	16	I	These pins form a reference oscillator when connected to an external parallel resonant crystal (10.24MHz)
OSC OUT	1	O	
MODE	2	I	This pin is for selecting handset/base mode. When mode is high, the device is base mode. When mode is low, the device handset mode. This input is normally pull-downed.
SBN	3	I	This pin is used to save power consumption when not transmitting. When SBN is high, both the transmit and receive loops are in operation. When SBN is low, but the transmit loop is disabled. This input is normally pull-downed.
	4	O	No connection
DA0	5	I	These pins are used to select one of 10 channels. The frequency assignments are shown in Table 1 and 2. These pins are normally pull-downed.
DA1	6		
DA2	7		
DA3	8		
PTIF	9	I	This is input to programmable counter for transmit loop. This signal is typically derived from the loop VCO and AC coupled. For large signal, it needs DC coupling. The minimum input voltage is $200\text{mV}_{P-P}$ .
LDN	10	O	This pin is used to indicate an unlock condition. it is a p-channel open-drain output.
PDT	11	O	This is 3-state output of the transmit phase detector for use as loop error signals.
Vss	12	power	Ground for all internal circuits.
PDR	13	O	This is 3-state output of the receive phase detector for use as loop error signals.
PRIF	14	I	This is input to programmable counter for receive loop. This signal is typically derived from the loop VCO and AC coupled. For large signal, it needs DC coupling. The minimum input voltage is $200\text{mV}_{P-P}$ .
V <sub>DD</sub>	15	power	Positive supply voltage.

# DMD 5602

ELECTRICAL CHARACTERISTICS

CHARACTERISTIC	SYMBOL	TEST CONDITION		VDD (V)	GUARANTEED LIMIT		UNIT
					MIN.	MAX.	
Power Supply Range	$V_{DD}$	—		—	2.5	5.5	V
Output Voltage	$V_{OL}$	$I_{out}=0$ $V_{IN}=V_{DD}$ or 0	Low	2.5	—	0.05	V
				5.5	—	0.05	
	$V_{OH}$		High	2.5	2.45	—	
				5.5	5.45	—	
Input Voltage	$V_{IL}$	$I_{out}=0.5V$ or $V_{DD}-0.5V$	Low	2.5	—	0.75	V
				5.5	—	1.65	
	$V_{IH}$		High	2.5	1.75	—	
				5.5	3.85	—	
Output Current	$I_{OL}$	$V_{out}=2.2V$ $V_{out}=5.0V$	Source	2.5	-0.18	—	mA
				5.5	-0.55	—	
	$I_{OH}$		Sink	2.5	0.18	—	
				5.5	0.55	—	
Input Current	$I_{IL}$	$V_{IN}=0$	OSC <sub>IN</sub> PTIF PRIF	2.5	—	-30	$\mu A$
				5.5	—	-66	
			Data SBN Mode	2.5	—	-0.05	
				5.5	—	-0.11	
	$I_{IH}$	$V_{IN}=V_{DD}-0.5$	OSC <sub>IN</sub> PTIF PRIF	2.5	—	30	
				5.5	—	66	
			Data SBN Mode	2.5	—	50	
				5.5	—	121	
Standby Current	$I_{DD}$	SBN=V <sub>SS</sub> or open	2.5	—	1.4	mA	
			5.5	—	3.6		
Operating Current	$I_{DD}$	200mV <sub>p-p</sub> Input at PTIF, PRIF, SBN=V <sub>DD</sub>	2.5	—	2.8	mA	
			5.5	—	6.2		
Input Frequency	$F_{IN1}$	Input=200mV <sub>p-p</sub>	PRIF	3.0 ~5.0	—	60	MHZ
	$F_{IN2}$		PTIF		—	60	
	$F_{OSC}$		osc in		—	12	

# DMD 5602

BASESET FREQUENCIES (Mode=High)

CH	CHANNEL DATA				RECEIVE			TRANSMIT		
	DA3	DA2	DA1	DA0	F <sub>RX</sub>	F <sub>IN1</sub>	N*	F <sub>TX</sub>	F <sub>IN2</sub>	N*
1	0	0	0	1	49.670	38.975	7795	46.610	46.610	9322
2	0	0	1	0	49.845	39.150	7830	46.630	46.630	9326
3	0	0	1	1	49.860	39.165	7833	46.670	46.670	9334
4	0	1	0	0	49.770	39.075	7815	46.710	46.710	9342
5	0	1	0	1	49.875	39.180	7836	46.730	46.730	9346
6	0	1	1	0	49.830	39.135	7827	46.770	46.770	9354
7	0	1	1	1	49.890	39.195	7839	46.830	46.830	9366
8	1	0	0	0	49.930	39.235	7847	46.870	46.870	9374
9	1	0	0	1	49.990	39.295	7859	46.930	46.930	9386
10	1	0	1	0	49.970	39.275	7855	46.970	46.970	9394

Notes : 1.  $N^* = F_{IN} / F_{REF}$

where  $\left\{ \begin{array}{l} F_{IN} \text{ is the VCO frequency} \\ F_{REF} \text{ is the reference frequency (5KHz)} \end{array} \right.$

2. Other input combinations will be defaulted to channel 10

# DMD 5602

HANDSET FREQUENCIES (Mode=Low)

CH	CHANNEL DATA				RECEIVE			TRANSMIT		
	DA3	DA2	DA1	DA0	F <sub>RX</sub>	F <sub>IN1</sub>	N*	F <sub>TX</sub>	F <sub>IN2</sub>	N*
1	0	0	0	1	46.610	35.915	7183	49.670	49.670	9934
2	0	0	1	0	46.630	35.935	7187	49.845	49.845	9969
3	0	0	1	1	46.670	35.975	7195	49.860	49.860	9972
4	0	1	0	0	46.710	36.015	7203	49.770	49.770	9954
5	0	1	0	1	46.730	36.035	7207	49.875	49.875	9975
6	0	1	1	0	46.770	36.075	7215	49.830	49.830	9966
7	0	1	1	1	46.830	36.135	7227	49.890	49.890	9978
8	1	0	0	0	46.870	36.175	7235	49.930	49.930	9986
9	1	0	0	1	46.930	36.235	7247	49.990	49.990	9998
10	1	0	1	0	46.970	36.275	7255	49.970	49.970	9994

Notes : 1.  $N^* = F_{IN} / F_{REF}$

where  $\left\{ \begin{array}{l} F_{IN} \text{ is the VCO frequency} \\ F_{REF} \text{ is the reference frequency (5KHz)} \end{array} \right.$

2. Other input combinations will be defaulted to channel 10

# DMD 5602

## TEST AND APPLICATION CIRCUIT

