

DN8899UAS

Hall IC for alternative magnetic field (SOH-4D type)

■ Overview

The DN8899UAS is a Hall IC in which a Hall element, an amplifier circuit, Schmidt circuit, stabilized power supply and temperature compensation circuit are integrated onto a single chip using IC technology. It amplifies Hall element output in the amplifier and converts it into a digital signal through the Schmidt circuit so as to drive the TTL or MOS IC directly.

The characteristics are guaranteed at a normal temperature (25°C) and a high temperature (135°C).

■ Features

- The characteristics are tested and guaranteed at a normal temperature (25°C) and a high temperature (135°C) for all devices.
- High sensitivity and low drift
- Stable temperature characteristics due to the built-in temperature compensation circuit
- Wide operating supply voltage range ($V_{CC} = 4.5 \text{ V to } 16 \text{ V}$)
- Operating in alternative magnetic field
- Direct drivability of TTL and MOS ICs with output
- Open collector output
- The hysteresis width of the zero-cross type includes "0" tesla point.
- Operation magnetic flux density does not depend on the supply voltage due to the built-in stabilization power supply.
- Surface mount package

■ Applications

- Speed sensor, position sensor, rotation sensor, key board switch and micro switch etc.

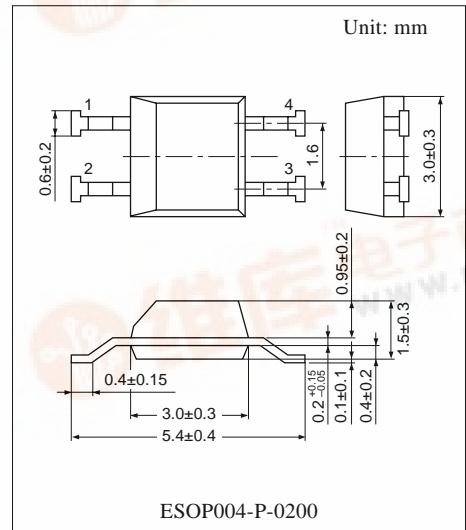

■ Block Diagram

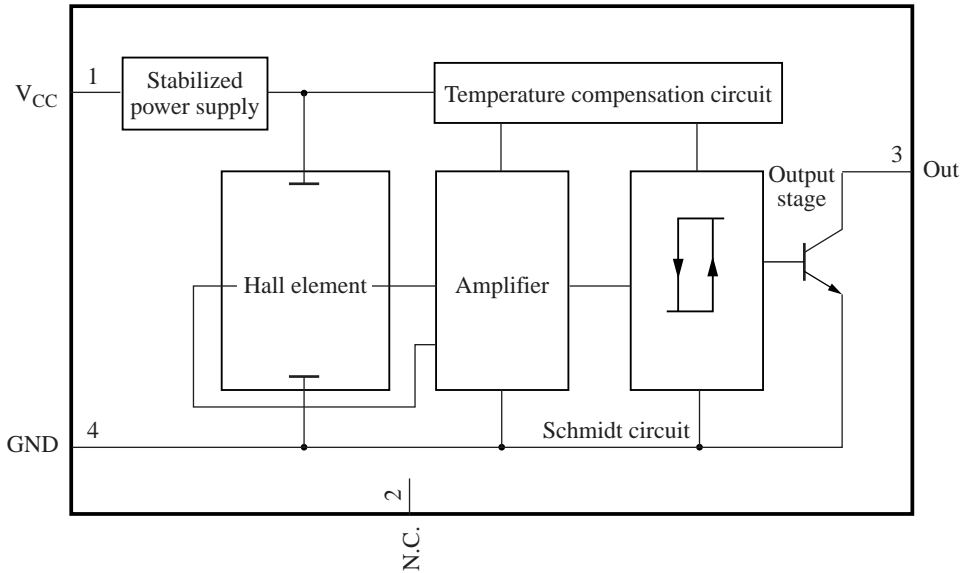

■ Pin Descriptions

| Pin No. | Description |
|---------|--------------------|
| 1 | Supply voltage pin |
| 2 | N.C. |
| 3 | Output pin |
| 4 | Ground pin |

■ Absolute Maximum Ratings

| Parameter | Symbol | Rating | Unit |
|-------------------------------|-----------|--------------|------|
| Supply voltage | V_{CC} | - 0.3 to +18 | V |
| Supply current | I_{CC} | 8 | mA |
| Power dissipation * | P_D | 37.5 | mW |
| Operating ambient temperature | T_{opr} | -40 to +135 | °C |
| Storage temperature | T_{stg} | -55 to +150 | °C |

Note) 1. Except for the operating ambient temperature and storage temperature, all ratings are for $T_a = 25^\circ\text{C}$.

2. The reverse insertion of this IC will cause its breakdown.

3. It will operate normally in several tens of ms after power on.

4. Use it within 100 mT of magnetic flux density, because if 100 mT or more is applied, the output of Hall IC is likely to be inverted.

5. Since this IC requires a special assembly, its anti-moisture characteristic is poor compared with other ordinary ICs.

If high reliability is required, you should dry PCB well after mounting and mold them with resin over the PCB.

6. *: Shows the allowable power consumption at $T_a = 135^\circ\text{C}$.

If the operation condition exceeds 60 mW, take measure in mounting and etc.

■ Recommended Operating Range

| Parameter | Symbol | Range | Unit |
|----------------|----------|-----------|------|
| Supply voltage | V_{CC} | 4.5 to 16 | V |

■ Electrical Characteristics

1. Electrical Characteristics at $T_a = 25^\circ\text{C}$

| Parameter | Symbol | Conditions | Min | Typ | Max | Unit |
|-----------------------------------|-----------|--|-----|-----|------|---------------|
| Operating magnetic flux density 1 | BH-L1 | $V_{CC} = 12\text{ V}$ | 0.1 | 6 | 12 | mT |
| Operating magnetic flux density 2 | BL-H1 | $V_{CC} = 12\text{ V}$ | -12 | -6 | -0.1 | mT |
| Hysteresis width | BW | $V_{CC} = 12\text{ V}$ | 7 | 12 | — | mT |
| Output voltage 1 | V_{OL1} | $V_{CC} = 4.5\text{ V}$, $I_O = 15\text{ mA}$ $B = 12\text{ mT}$ | — | — | 0.4 | V |
| Output voltage 2 | V_{OL2} | $V_{CC} = 16\text{ V}$, $I_O = 15\text{ mA}$ $B = 12\text{ mT}$ | — | — | 0.4 | V |
| Output current 1 | I_{OH1} | $V_{CC} = 4.5\text{ V}$, $V_O = 16\text{ V}$ $B = -12\text{ mT}$ | — | — | 10 | μA |
| Output current 2 | I_{OH2} | $V_{CC} = 16\text{ V}$, $V_O = 16\text{ V}$ $B = -12\text{ mT}$ | — | — | 10 | μA |
| Supply current 1 | I_{CC1} | $V_{CC} = 4.5\text{ V}$, $B = 12\text{ mT}$ | — | — | 6.5 | mA |
| Supply current 2 | I_{CC2} | $V_{CC} = 16\text{ V}$, $B = 12\text{ mT}$ | — | — | 7.0 | mA |

2. Electrical Characteristics at $T_a = 135^\circ\text{C} \pm 10^\circ\text{C}$

| Parameter | Symbol | Conditions | Min | Typ | Max | Unit |
|-----------------------------------|-----------|--|-----|-----|-----|---------------|
| Operating magnetic flux density 3 | BH-L2 | $V_{CC} = 12\text{ V}$ | — | — | 15 | mT |
| Operating magnetic flux density 4 | BL-H2 | $V_{CC} = 12\text{ V}$ | -15 | — | — | mT |
| Output voltage 3 | V_{OL3} | $V_{CC} = 4.5\text{ V}$, $I_O = 15\text{ mA}$ $B = 15\text{ mT}$ | — | — | 0.4 | V |
| Output voltage 4 | V_{OL4} | $V_{CC} = 16\text{ V}$, $I_O = 15\text{ mA}$ $B = 15\text{ mT}$ | — | — | 0.4 | V |
| Output current 3 | I_{OH3} | $V_{CC} = 4.5\text{ V}$, $V_O = 16\text{ V}$ $B = -15\text{ mT}$ | — | — | 10 | μA |
| Output current 4 | I_{OH4} | $V_{CC} = 16\text{ V}$, $V_O = 16\text{ V}$ $B = -15\text{ mT}$ | — | — | 10 | μA |
| Supply current 3 | I_{CC3} | $V_{CC} = 4.5\text{ V}$, $B = 15\text{ mT}$ | — | — | 6.5 | mA |
| Supply current 4 | I_{CC4} | $V_{CC} = 16\text{ V}$, $B = 15\text{ mT}$ | — | — | 7.0 | mA |

Note) 1. Symbol BH-L stands for the operating magnetic flux density where its output level varies from high to low.

2. Symbol BL-H stands for the operating magnetic flux density where its output level varies from low to high.

3. The variation of operating magnetic flux density does not depend on supply voltage due to its built-in stabilized power source. (V_{CC} should be confined to the range of 4.5 V to 16 V.)

■ Electrical Characteristics (continued)

3. Design reference data at $T_a = 25^\circ\text{C}$

Note) The characteristics listed below are not guaranteed values for design.

| Parameter | Symbol | Conditions | Min | Typ | Max | Unit |
|--|---------------------|---|-----|------|-----|------|
| Operating magnetic flux density supply voltage dependency 1 * ¹ | $\Delta\text{BH-L}$ | Difference of operating magnetic flux density (BH-L) at $V_{\text{CC}} = 4.5\text{ V}, 16\text{ V}$ | — | 0 | — | mT |
| Operating magnetic flux density supply voltage dependency 2 * ¹ | $\Delta\text{BL-H}$ | Difference of operating magnetic flux density (BL-H) at $V_{\text{CC}} = 4.5\text{ V}, 16\text{ V}$ | — | 0.6 | — | mT |
| Hysteresis width supply voltage dependency * ¹ | ΔBW | Difference of hysteresis width (BW) at $V_{\text{CC}} = 4.5\text{ V}, 16\text{ V}$ | — | -0.6 | — | mT |
| Operating magnetic flux density time lapse variation quantity * ² | ΔB | — | — | 3 | 5 | mT |

Note) *1: A test circuit shall be identical with "■ Electrical Characteristics".

| | | |
|---------------------------------|-----------|---------------------------|
| *2: At $T_a = 25^\circ\text{C}$ | BH-L max. | $12 + 5 = 17\text{ mT}$ |
| | BL-H min. | $-12 - 5 = -17\text{ mT}$ |
| At $T_a = 135^\circ\text{C}$ | BH-L max. | $15 + 5 = 20\text{ mT}$ |
| | BL-H min. | $-15 - 5 = -20\text{ mT}$ |

Therefore, the magnetic flux density to be applied to Hall IC must be $\pm 20\text{ mT}$ or more at $T_a = 135^\circ\text{C}$.

Be cautious on use of a permanent magnet as it has its own temperature characteristic and time lapse variation.

■ Caution on use of Hall ICs

As the Hall IC is often used to detect movement, the position of a Hall IC may be changed, and there is the risk of a change in detection level, if exposed to shock or vibration over a long period of time. Secure the IC by applying adhesive to the package or placing in a dedicated case.

1. On mounting of the surface mount type (ESO004-P-0200 package)

Set pin 2 to open or connect to GND. It will be damaged if it is connected to V_{CC} . When mounted on the printed circuit board, the Hall IC may be highly stressed by the warp that may occur from the soldering. This may also cause a change in the operating magnetic flux density and a deterioration of its resistance to moisture.

Be cautious to keep the device from being stressed thermally or mechanically up to the 2 mm distance from the package.



2. On using flux in soldering

Choose a flux which does not include ingredients from halogen group, such as chlorine, fluorine, etc. The ingredients of halogen group may enter where the lead frame and package resin joint, causing corrosion and the disconnection of the aluminum wiring on the surface of an IC chip.

3. On fixing a Hall IC with the holder

When a Hall IC is mounted on the printed circuit board with a holder and the coefficient of expansion of the holder is large, the lead wire of the Hall IC will be stretched and it may give a stress to the Hall IC.

If the lead wire is stressed intensely due to the distortion of holder or board, the adhesives between the package and the lead wire may be weakened and cause a minute gap resulting in the deterioration of its resistance to moisture.

Sensitivity may also be changed by this stress.

4. Power supply line/power transmission line

If a power supply line/power transmission line becomes longer, noise and/or oscillation may be found on the line. In this case, set the capacitor of 0.1 μF to 10 μF near a Hall IC to prevent it.

If a voltage of 18 V or more is thought to be applied to the power supply line (flyback voltage from coil or the ignition pulse, etc.), avoid it with external components (capacitor, resistor, Zener diode, diode, surge absorbing elements, etc.).

5. V_{CC} and GND

Do not reverse V_{CC} and GND. If the V_{CC} and GND pins are reversely connected, this IC will be destroyed. If the IC GND-pin voltage is set higher than other pin voltage, the IC configuration will become same as a forward biased diode. Therefore, it will turn on at the diode forward voltage (approximately 0.7 V), and a large current will flow through the IC, ending up in its destruction. (This is common to Monolithic IC.)

6. Cautions on power ON of Hall IC

When a Hall IC is turned ON, the position of the magnet or looseness may change the output of a Hall IC, and a pulse may be generated. Therefore, care should be given whenever the output state of a Hall IC is critical when the supply power is ON.

7. When magnetic force of magnet is too strong

Output may be inverted when applying a magnetic flux density of 100mT or more. Accordingly, magnetic flux density should be used within the range of 100 mT.

■ Technical Data

- Position of a Hall element (unit in mm)

A Hall element is placed on the shaded part in the figure.

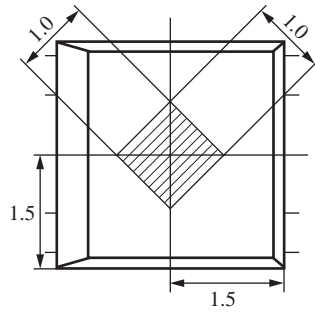

- Magneto-electro conversion characteristics

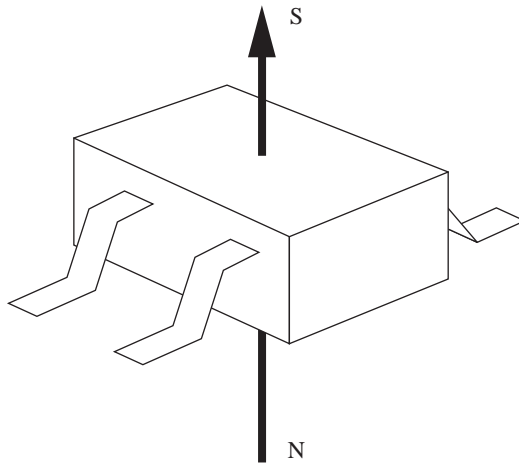

Direction of applied magnetic field

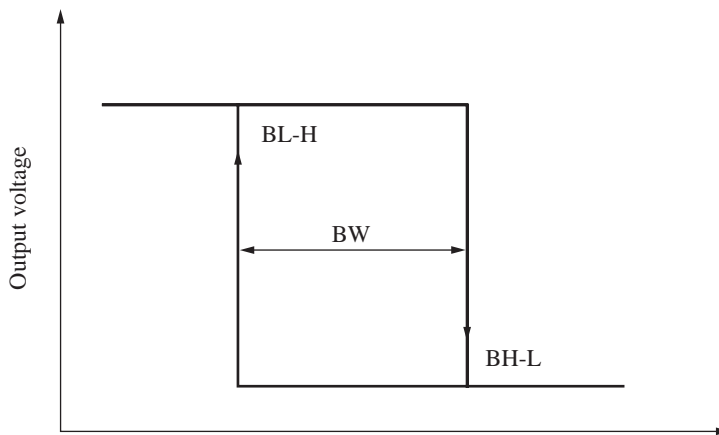

Applied magnetic flux density B