



M/A-COM



## Low Cost SMT Dual Band Diplexer 824 – 960 / 1850 – 1990 MHz (AMPS/PCS) 880 – 960 / 1700 – 1900 MHz (GSM/DCS)

### Features

- Small Size and Low Profile
- Industry Standard SOIC-8 SMT Plastic Package
- Superior Repeatability
- Passbands 824 - 960 MHz and 1850 - 1990 MHz
- Passbands 880 - 960 MHz and 1700 - 1900 MHz
- Typical Passband Insertion Loss: 0.5 dB
- 2 Watt Power Handling
- Low Cost

### Description

M/A-COM's DP52-0002 is an IC-based monolithic diplexer in a low cost SOIC-8 SMT plastic package. This diplexer is ideally suited for applications where small size, low insertion loss, superior repeatability and low cost are required. Typical applications include AMPS/PCS and GSM/DCS dual mode portable devices.

The DP52-0002 is fabricated using a passive-integrated circuit process. The process features full-chip passivation for increased performance and reliability.

### SO-8

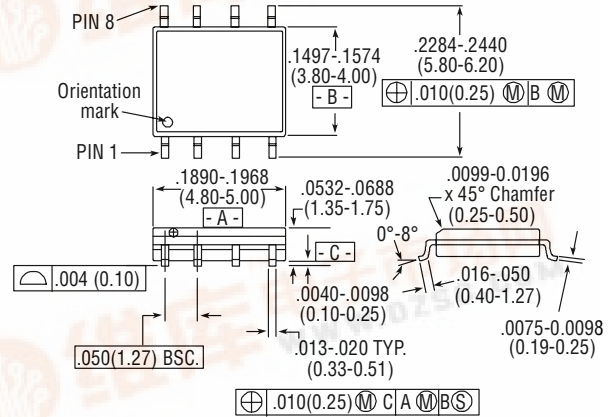

8- Lead SOP outline dimensions

Narrow body .150

(All dimensions per JEDEC No. MS-012-AA, Issue C)

Dimensions in ( ) are in mm.

Unless Otherwise Noted: .xxx = ± 0.010 (.xx = ± 0.25)  
.xx = ± 0.02 (x = ± 0.5)

### Ordering Information

Part Number	Package
DP52-0002	SOIC-8-Lead Plastic Package
DP52-0002-TR	Forward Tape and Reel <sup>1</sup>

1. If specific reel size is required, consult factory for part number assignment.

### 824 - 960 / 1850 - 1990 MHz Typical Electrical Specifications<sup>1</sup>, T<sub>A</sub> = +25°C

Parameters	Units	Min.	Typ.	Max.
Passband Insertion Loss	dB	—	0.5	0.8
Stopband Isolation	dB	12	18	—
Passband VSWR	—	—	1.4:1	1.7:1

1. All specifications apply with a 50-ohm source and load impedance.

### 880 - 960 / 1700 - 1900 MHz Typical Electrical Specifications<sup>1</sup>, T<sub>A</sub> = +25°C

Parameters	Units	Min.	Typ.	Max.
Passband Insertion Loss	dB	—	0.5	0.9
Stopband Isolation	dB	12	18	—
Passband VSWR	—	—	1.5:1	1.8:1

1. All specifications apply with a 50-ohm source and load impedance.



**Absolute Maximum Ratings<sup>1</sup>**

Parameter	Absolute Maximum
Input Power	2W CW
Operating Temperature	-40°C to +85°C
Storage Temperature	-65°C to 150°C

1. Exceeding these limits may cause permanent damage.

**Functional Diagram**

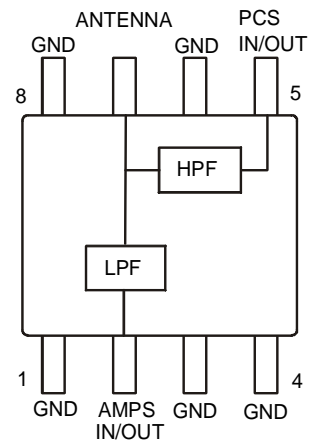

All unused pins must be RF and DC grounded.  
Pins 1 and 4 are thermal ground contacts.

**Recommended PCB Configuration**

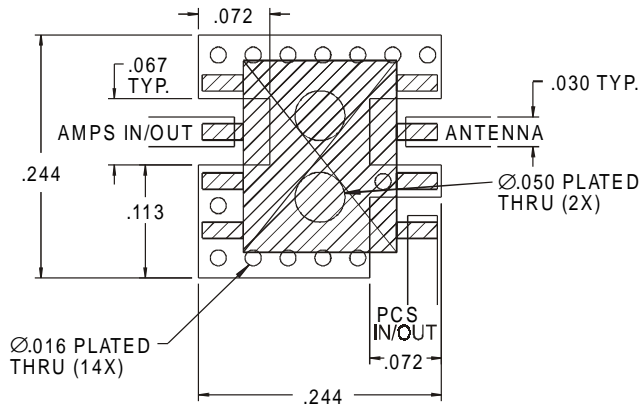

CIRCUIT MATERIAL: FR-4, .016 THICK.

**Typical Performance @ +25°C**

**Insertion Loss vs. Frequency**

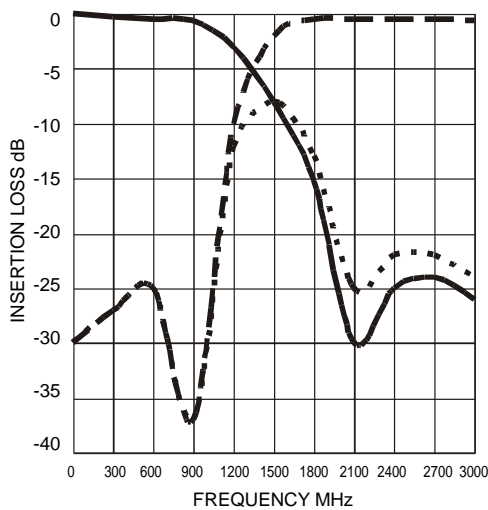

— Antenna / AMPS, GSM  
 - - - Antenna / PCS, DCS  
 . . . . AMPS / PCS GSM/DCS

**VSWR vs. Frequency**

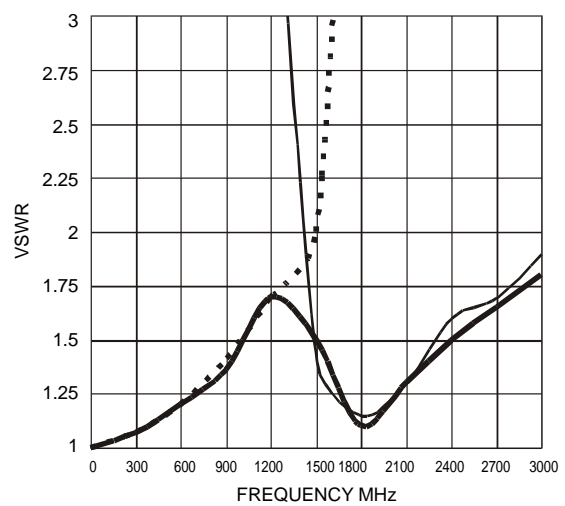

— Antenna  
 . . . . AMPS, GSM  
 - - - PCS, DCS