

SBD Type : 21DQ03L

OUTLINE DRAWING

FEATURES

- * Miniature Size
- * Extremely Low Forward Voltage Drop
- * Low Power Loss, High Efficiency
- * High Surge Capability
- * 30volts trough 100volts Types Available
- * 52mm Inside Tape Spacing Package Available

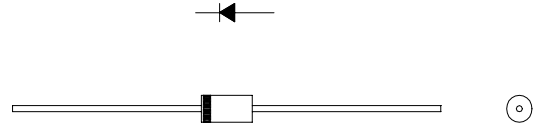

Maximum Ratings

Approx Net Weight:0.38g

Rating		Symbol	21DQ03L			Unit
Repetitive Peak Reverse Voltage		V_{RRM}	30			V
Average Rectified Output Current	Without Fin or P.C.Board	I_o	1.42	$T_a=25^{\circ}C$	Half Sine Wave Resistive Load	A
	P.C.Board Mounted *		1.7	$T_a=30^{\circ}C$		
RMS Forward Current		$I_{F(RMS)}$	2.67			A
Surge Forward Current		I_{FSM}	50	Half Sine Wave,1cycle,Non-repetitive		A
Operating JunctionTemperature Range		T_{jw}	- 40 to + 150			$^{\circ}C$
Storage Temperature Range		T_{stg}	- 40 to + 150			$^{\circ}C$

Electrical • Thermal Characteristics

Characteristics	Symbol	Conditions	Min	Typ	Max	Unit
Peak Reverse Current	I_{RM}	$T_j= 25^{\circ}C, V_{RM}= V_{RRM}$	-	-	2	mA
Peak Forward Voltage	V_{FM}	$T_j= 25^{\circ}C, I_{FM}= 1.7 A$	-	-	0.45	V
Thermal Resistance(Junction to Ambient)	$R_{th(j-a)}$	Without Fin or P.C.Board	-	-	105	$^{\circ}C/W$
		P.C.Board mounted *			80	

* :Print Lands = 5x5 mm,Both Sides

21DQ03L OUTLINE DRAWING (Dimensions in mm)

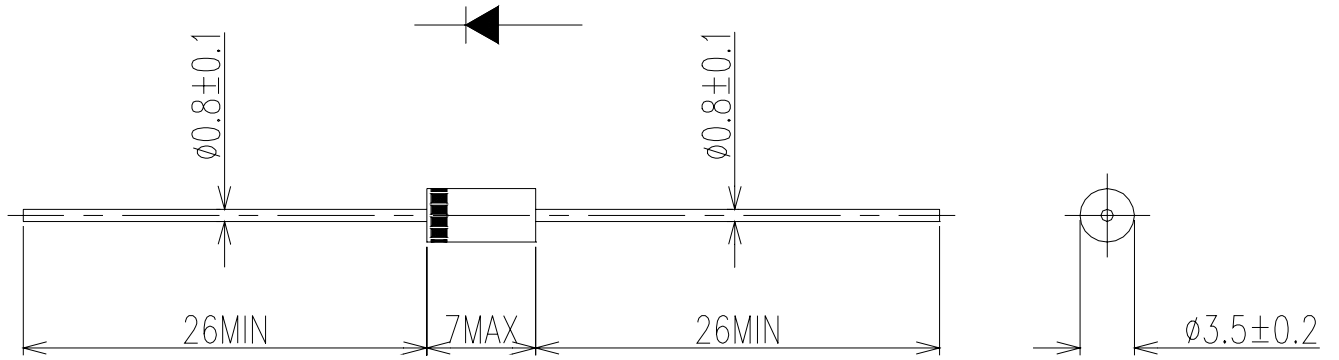

FORWARD CURRENT VS. VOLTAGE

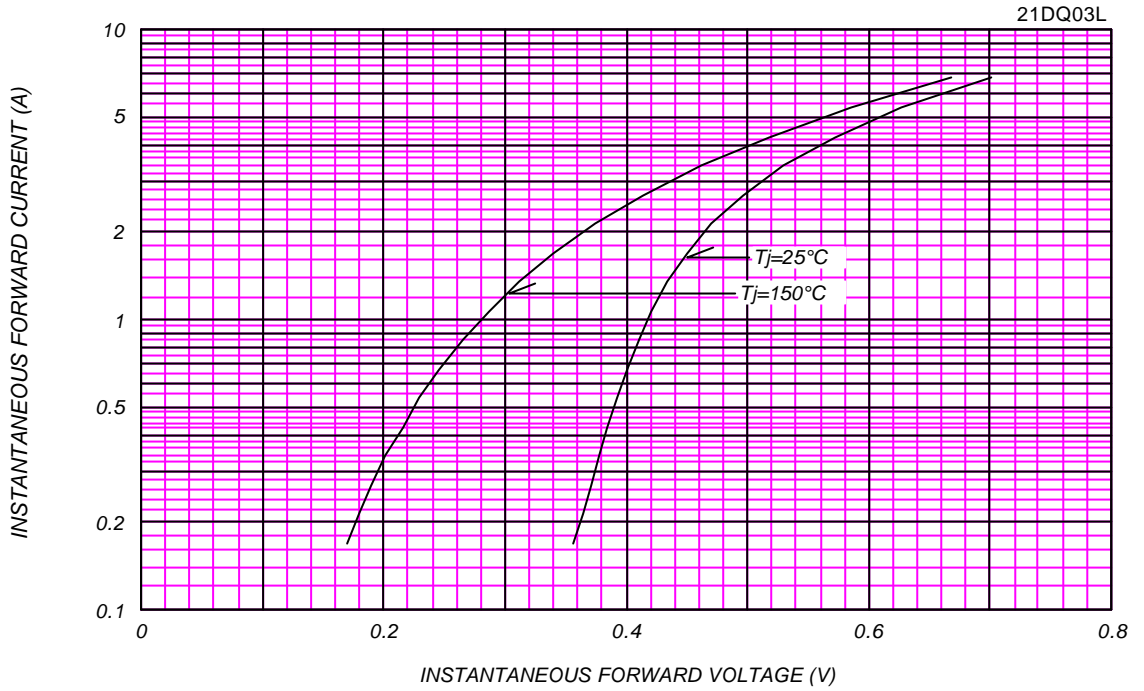

AVERAGE FORWARD POWER DISSIPATION

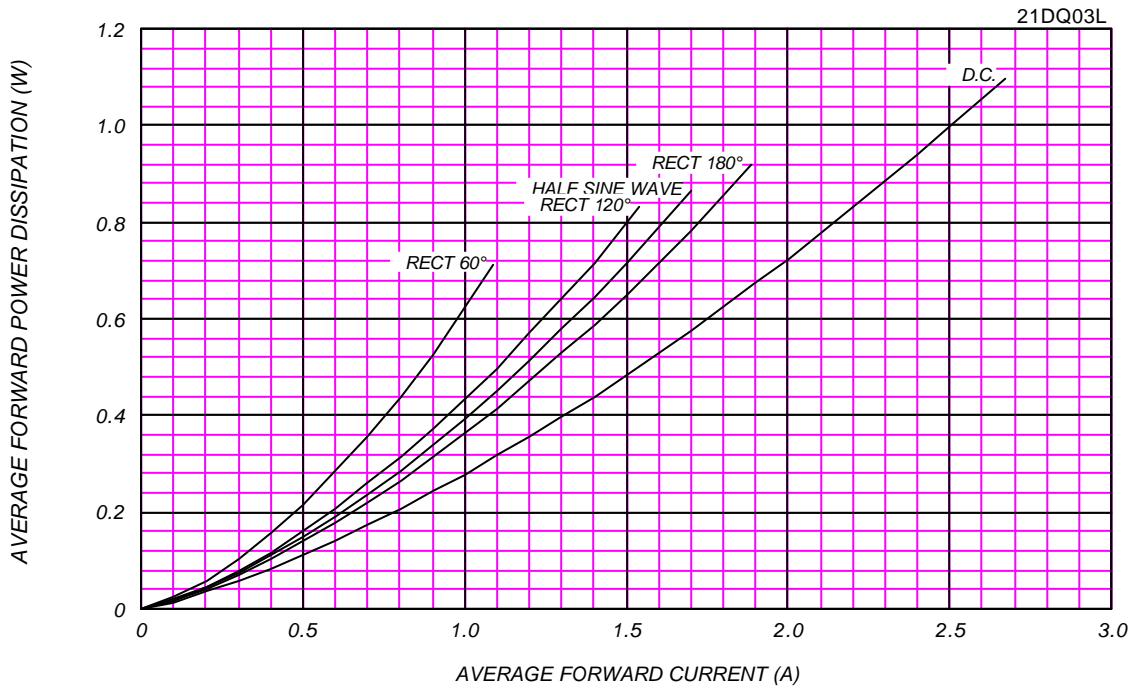

PEAK REVERSE CURRENT VS. PEAK REVERSE VOLTAGE

T_j = 150 °C

21DQ03L

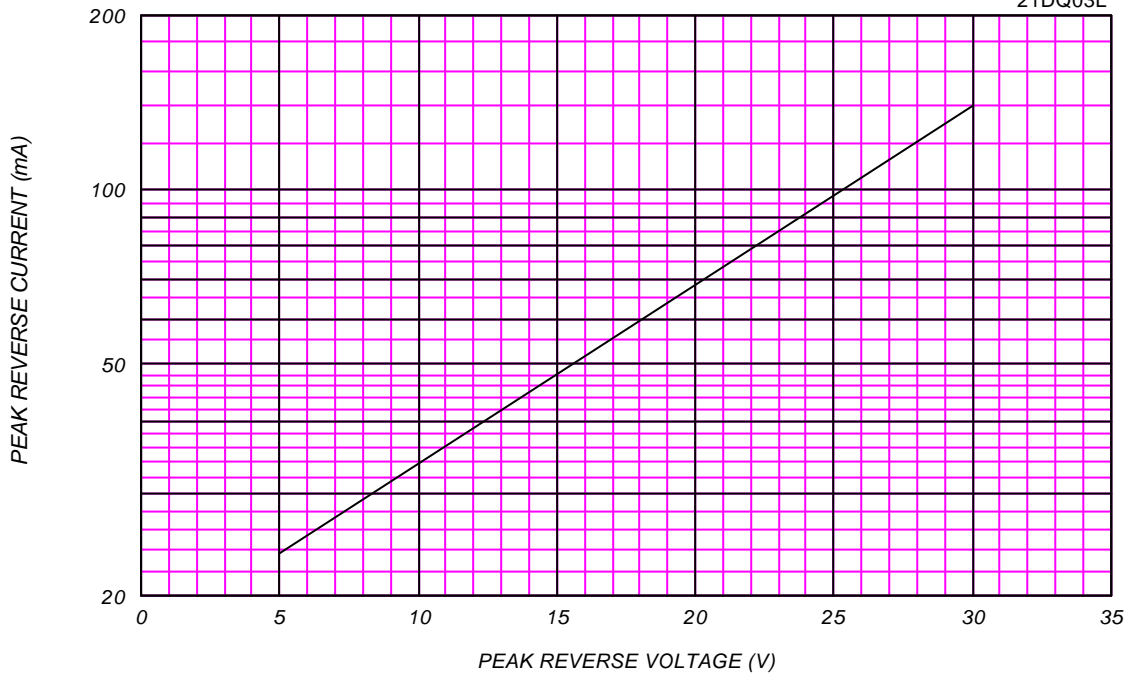

AVERAGE REVERSE POWER DISSIPATION

21DQ03L

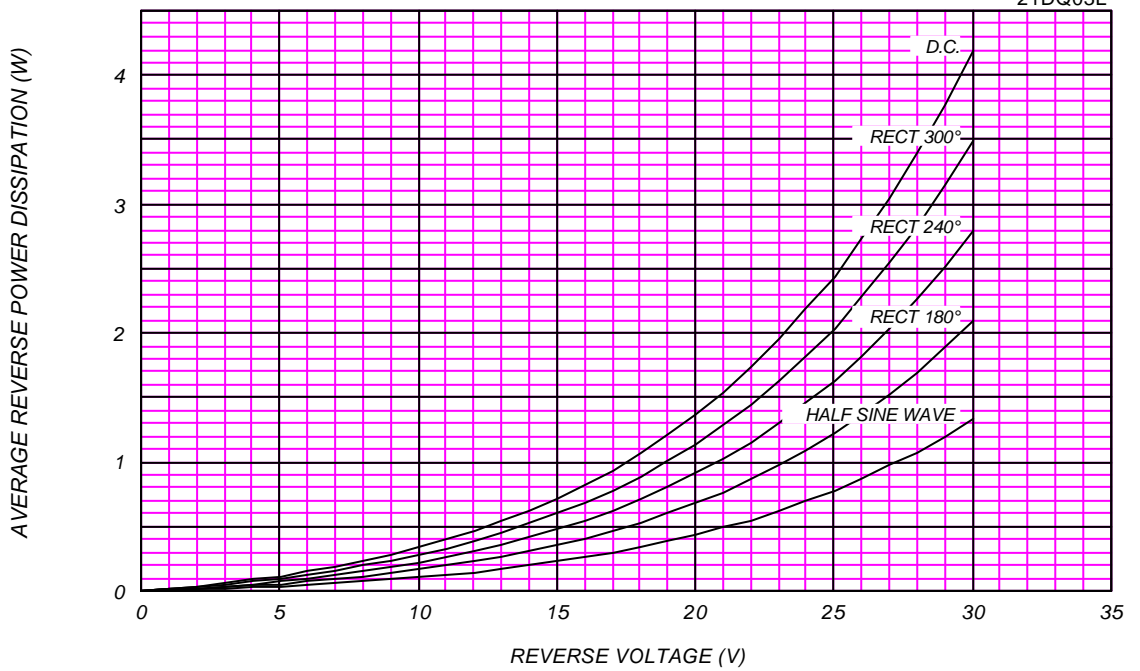

AVERAGE FORWARD CURRENT VS. AMBIENT TEMPERATURE

Without Fin or P.C. Board

21DQ03L

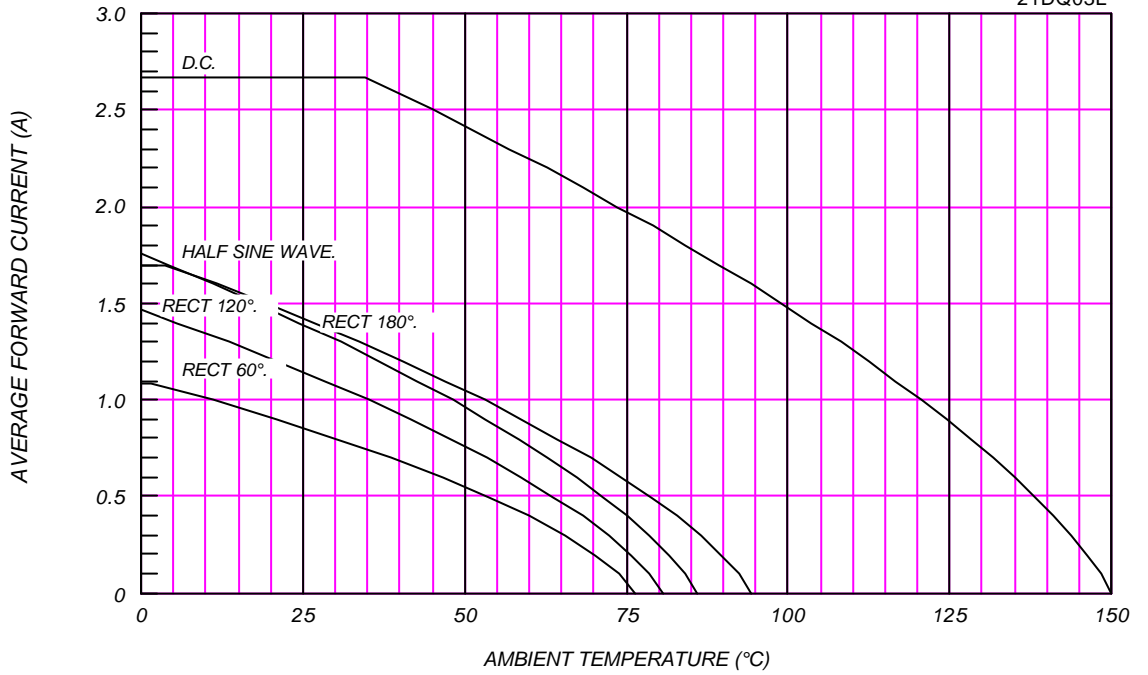

AVERAGE FORWARD CURRENT VS. AMBIENT TEMPERATURE

P.C. Board mounted (L=8mm, Print Land = 10x10mm, Both Sides)

21DQ03L

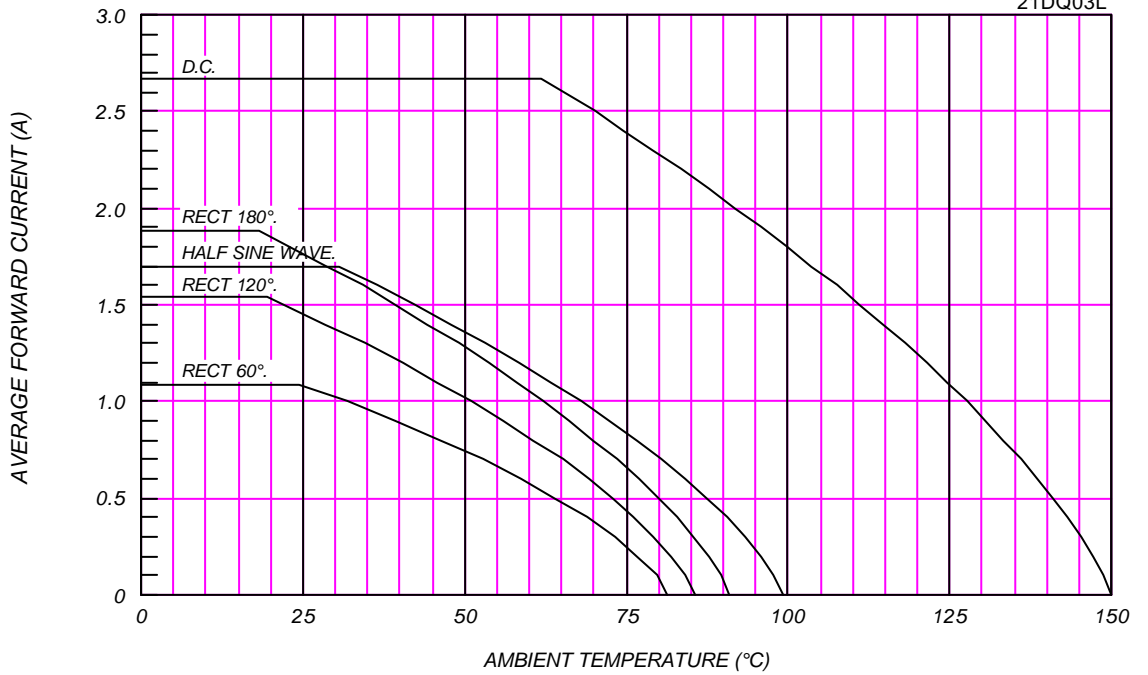

SURGE CURRENT RATINGS

f=50Hz,Half Sine Wave,Non-Repetitive,No Load

21DQ03L

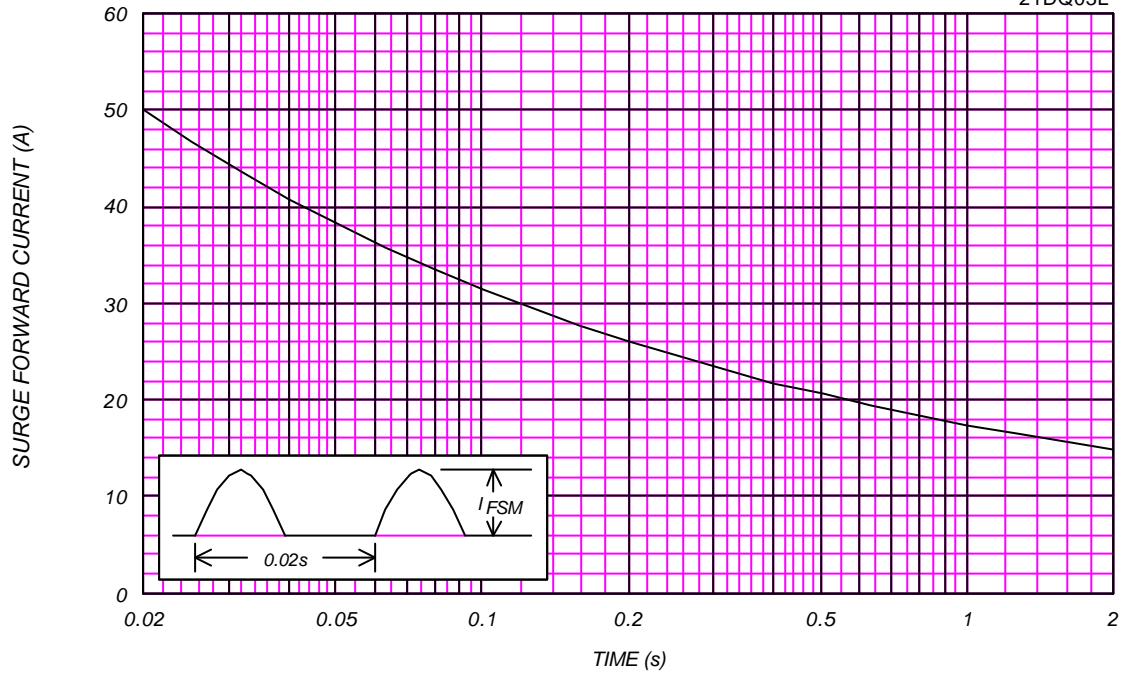

JUNCTION CAPACITANCE VS. REVERSE VOLTAGE

$T_j=25^{\circ}\text{C}$, $V_m=20\text{mV}_{\text{RMS}}$, $f=100\text{kHz}$, Typical Value

21DQ03L

