



# DS2188 T1/CEPT Jitter Attenuator

www.dalsemi.com

## FEATURES

- Attenuates clock and data jitter present in T1 or CEPT lines
- Meets the jitter attenuation templates outlined in TR62411, TR-TSY-000170, G.735, and G.742
- Only one external component required; either a 6.176 MHz (T1) or 8.192 MHz (CEPT) crystal
- Selectable buffer size of 128 or 32 bits
- Jitter attenuation is easily disabled
- Single +5V supply; low-power CMOS technology
- Available in 16-pin DIP and 16-pin SOIC (DS2188S)
- Companion to the DS2186 Transmit Line and DS2187 Receive Line Interface

## PIN ASSIGNMENT

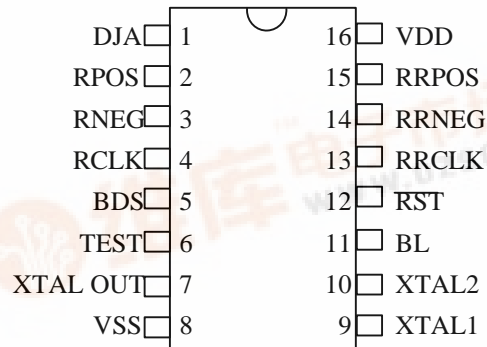

16-Pin DIP/SOIC

## DESCRIPTION

The DS2188 T1/CEPT Jitter Attenuator Chip contains a 128 X 2-bit buffer which, in conjunction with an external 4X crystal, is used to attenuate the incoming jitter present in clock and data. The device meets all of the latest applicable specifications including those outlined in TR 62411 (Accunet\* T1.5 Service Description and Interface Specifications, December 1990), TR-TSY-000170 (Digital Cross-Connect System Requirements and Objectives, November 1985), and the CCITT Recommendations G.735 and G.742. The DS2188 is compatible with the DS2180A T1/ISDN Primary Rate Transceiver and DS2181A CEPT Transceiver and is the companion to the DS2187 T1/CEPT Receive Line Interface and DS2186 T1/CEPT Transmit Line Interface. It can also be used in conjunction with the DS2190 T1 Network Interface Unit.

## OVERVIEW

The RCLK input is fed to a 128 x 2-bit FIFO where it drives the write pointer for the positive (RPOS) and negative (RNEG) data. The read pointer of the FIFO and RRCLK is generated by dividing the frequency of the crystal connected to XTAL1 and XTAL2 by four. The frequency of the crystal is adjusted by a DPLL to the long-term average frequency of RCLK. As long as the jitter present at RCLK is less than 120 unit intervals peak-to-peak (UIpp), then the FIFO buffer will be able to absorb the incoming jitter and it will be attenuated in accordance with TR 62411 (December 1990). In this situation, the BL (Buffer Limit) pin will remain low. Figures 1 and 2 illustrate the DS2188 Jitter Attenuator performance.

If the incoming jitter has excursions greater than 120 UIpp, then the crystal is adjusted to track the short-term frequency variations of the incoming signal so that there is no loss of data. This adjustment is accomplished by dividing the 4X crystal by either 3 ½ or 4 ½ instead of 4. When the incoming jitter is greater than 120 UIpp, the BL pin will transition high. When the incoming jitter returns to less than 120 UIpp, the BL pin will return low.

The jitter attenuator in the DS2188 can be disabled by tying the DJA pin high. When the jitter attenuator is disabled, the FIFO is bypassed and jitter received at RCLK, RPOS and RNEG is passed through the DS2188 to RRCLK, RRPOS, and RRNEG. In this situation, the BL pin has no significance and XTAL OUT will not be coherent with RRCLK.

How to use the DS2188 with Dallas Semiconductor's other T1 and CEPT line interface parts is illustrated in Figures 3 through 5. Figure 3 illustrates how to use the DS2188 in the receive path along with a DS2187 Receive Line Interface. Figure 4 illustrates how to use the DS2188 in the transmit path with the DS2186 Transmit Line Interface. Also, see DS2188 Application Note, "Operation at Speeds Greater than E1" for additional information.

## **BUFFER DEPTH SELECT**

The buffer size on the DS2188 can be configured to either 128 or 32 bits via the BDS pin. If BDS is tied low, then the buffer depth will be 128 bits and hence can handle input jitter up to 120 UIpp without losing its full attenuation capabilities as is described above in the Over-view. If BDS is tied high, then the buffer depth is shortened to 32 bits. In this configuration, the DS2188 can handle input jitter up to 28 UIpp without losing its full jitter attenuation capabilities. The user may wish to limit the buffer size to 32 bits in applications where through-put delay is critical or into existing applications that already have 32 bits of buffer space.

## **RESET**

The buffer on the DS2188 is automatically centered on power-up. The user can recenter the 128-bit (or 32-bit) buffer on demand via the  $\overline{\text{RST}}$  pin. The  $\overline{\text{RST}}$  pin on the DS2188 is negative-edge triggered. When this pin transitions from high-to-low, the buffer is recentered. The  $\overline{\text{RST}}$  pin can be held either high or low during operation of the DS2188; only a negative going signal will initiate a recentering. In most cases, a reset of the DS2188 will corrupt data that is currently passing through the buffer.

**DS2188 TI JITTER ATTENUATION PERFORMANCE Figure 1**

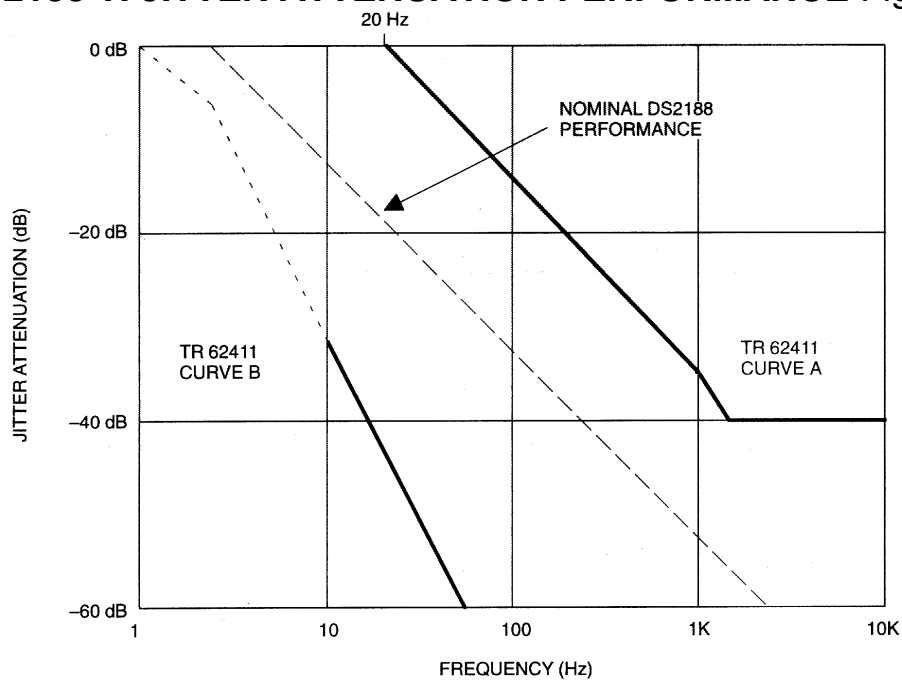

**DS2188 CEPT JITTER ATTENUATION PERFORMANCE Figure 2**

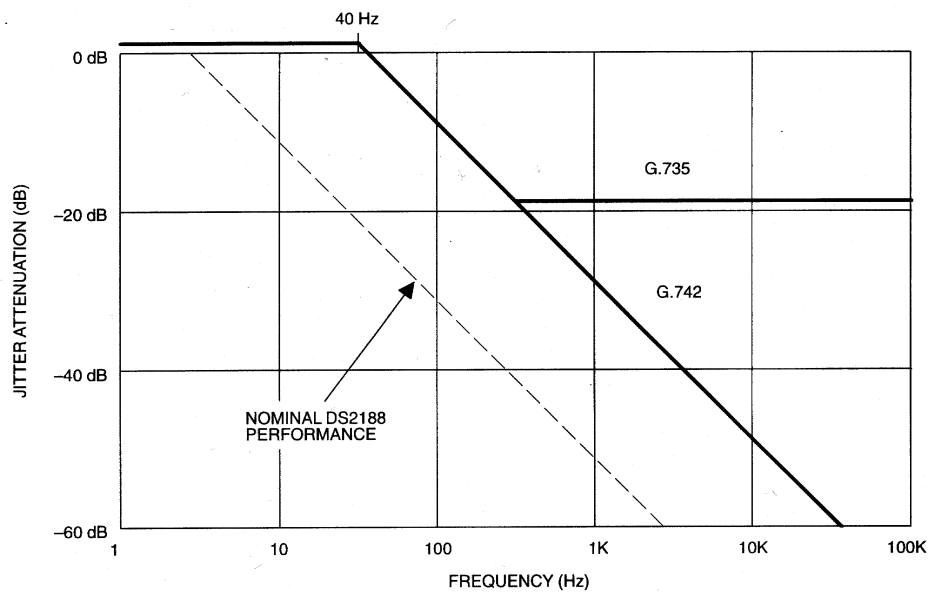

### DS2188 IN THE RECEIVE PATH Figure 3

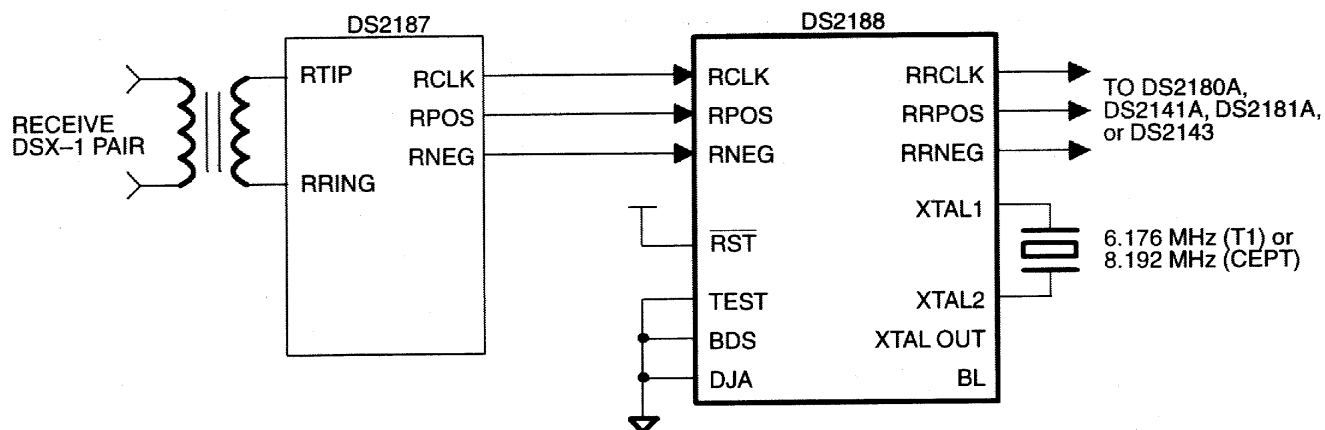

### DS2188 IN THE TRANSMIT PATH Figure 4

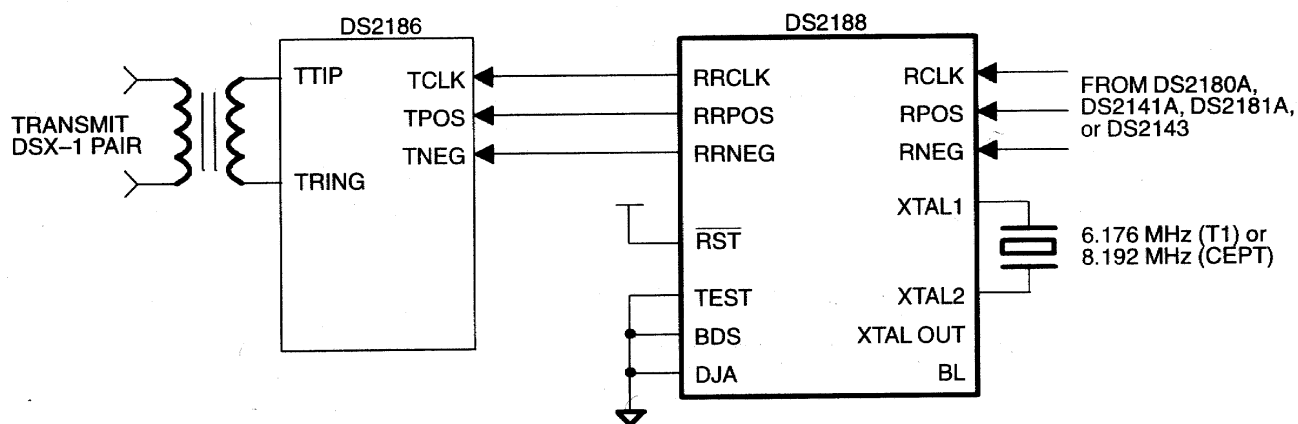

**PIN DESCRIPTION Table 1**

PIN	SYMBOL	TYPE	DESCRIPTION
1	DJA	I	<b>Disable Jitter Attenuation.</b> When high, jittered data and clock at RPOS, RNEG, and RCLK are passed directly to RRPOS, RRNEG, and RRCLK.
2	RPOS	I	<b>Receive Positive Data Input.</b> Jittered data input. Sampled on the falling edge of RCLK.
3	RNEG	I	<b>Receive Negative Data Input.</b> Jittered data input. Sampled on the falling edge of RCLK.
4	RCLK	I	<b>Receive Clock Input.</b> Jittered input 1.544 MHz or 2.048 MHz clock.
5	BDS	I	<b>Buffer Depth Select.</b> 0 = 128 bits 1 = 32 bits
6	TEST	I	<b>Test Input.</b> In normal applications, this pin should be tied low. When tied high, used to verify free running frequency of XTAL.
7	XTAL OUT	O	<b>Crystal Frequency Output.</b> Buffered output of the 4X crystal connected to XTAL1 and XTAL2.
8	V <sub>SS</sub>	-	<b>Ground.</b> 0.0 volts.
9	XTAL1	I	<b>Crystal Connections.</b> In T1 environments, connect a 6.176 MHz crystal to these pins. In CEPT environments, connect a 8.192 MHz crystal to these pins.
10	XTAL2	O	
11	BL	O	<b>Buffer Limit.</b> Transitions high when the buffer fills or empties to within either 4 bits (BDS=0) or 2 bits (BDS=1) of its capacity. Indicates that the jitter at RCLK is greater than 120 UIpp (BDS=0) or 28 UIpp (BDS=1).
12	$\overline{\text{RST}}$	I	<b>Reset.</b> Negative-edge triggered; a high-low transition will recenter the buffer. Activation of this pin may corrupt data through the DS2188.
13	RRCLK	O	<b>Receive Reference Clock.</b> Dejittered 1.544 MHz or 2.048 MHz clock.
14	RRNEG	O	<b>Receive Reference Negative Data Output.</b> Dejittered data output. Updated on the rising edge of RRCLK.
15	RRPOS	O	<b>Receive Reference Positive Data Output.</b> Dejittered data output. Updated on the rising edge of RRCLK.
16	V <sub>DD</sub>	-	<b>Positive Supply.</b> 5.0 volts.

## CRYSTAL REQUIREMENTS

The DS2188 must have a crystal connected to the XTAL1 and XTAL2 pins. For T1 environments, the frequency of this crystal should be 6.176 MHz. For CEPT environments, the frequency of this crystal should be 8.192 MHz. Table 2 lists some suggested crystal manufacturers that are recommended for use with the DS2188. Also, see DS2188 Application Note, “Operation at Speeds Greater than E1” for additional information.

### CRYSTAL MANUFACTURERS Table 2

MANUFACTURER	PART #	FREQUENCY
JAN Crystal	6323-00, JC6A14	6.176 MHz
	6323-00, JC8A14	8.192 MHz
M-TRON	4575-002	6.176 MHz
	4575-001	8.192 MHz

### CRYSTAL SELECTION GUIDELINES FOR THE DS2188

PARAMETER	SPECIFICATION
Parallel resonant frequency	6.176 MHz (T1) or 8.192 MHz (CEPT)
Mode	Fundamental
Load capacitance	14 to 20 pF (16 pF preferred)
Tolerance	±50 ppm over 0 to 70°C
Pullability	CL = 10 pF, delta_f = +175 to +250 ppm CL = 45 pF, delta_f = -175 to -250 ppm
Effective series resistance	40 ohms maximum for 6.176 MHz 30 ohms maximum for 8.192 MHz
Crystal cut	AT

**ABSOLUTE MAXIMUM RATINGS\***

Voltage on Any Pin Relative to Ground	-0.1V to +7.0V
Operating Temperature	0° to 70°C
Storage Temperature	-55°C to +125°C
Soldering Temperature	260°C for 10 seconds

\* This is a stress rating only and functional operation of the device at these or any other conditions above those indicated in the operation sections of this specification is not implied. Exposure to absolute maximum rating conditions for extended periods of time may affect reliability.

**RECOMMENDED DC OPERATING CONDITIONS** (0°C to 70°C)

PARAMETER	SYMBOL	MIN	TYP	MAX	UNITS	NOTES
Input Logic 1	V <sub>IH</sub>	2.0		V <sub>CC</sub> +0.3	V	1
Input Logic 0	V <sub>IL</sub>	-0.3		+0.8	V	1
Supply	V <sub>DD</sub>	4.50		5.50	V	

**NOTE:**

1. Does not apply to XTAL1.

**CAPACITANCE** (t<sub>A</sub>=25°C)

PARAMETER	SYMBOL	MIN	TYP	MAX	UNITS	NOTES
Input Capacitance	C <sub>IN</sub>		5		pF	
Output	C <sub>OUT</sub>		10		pF	

**DC ELECTRICAL CHARACTERISTICS** (0°C to 70°C; V<sub>DD</sub> = 5.0V ± 10%)

PARAMETER	SYMBOL	MIN	TYP	MAX	UNITS	NOTES
Supply Current	I <sub>DD</sub>		7	12	mA	1
Input Leakage	I <sub>L</sub>	-1.0		+1.0	μA	2, 3
Output Current (2.4V)	I <sub>OH</sub>	-1.0			mA	3
Output Current (0.4V)	I <sub>OL</sub>	+4.0			mA	3

**NOTES:**

1. RCLK = 1.544 MHz; V<sub>DD</sub> = 5.50; outputs open.
2. V<sub>SS</sub> < V<sub>IN</sub> < V<sub>DD</sub>; XTAL1 = XTAL2 = V<sub>DD</sub>.
3. Does not apply to XTAL1 or XTAL2.

**AC ELECTRICAL CHARACTERISTICS** (0°C to 70°C;  $V_{DD} = 5.0V \pm 10\%$ )

PARAMETER	SYMBOL	MIN	TYP	MAX	UNITS	NOTES
RCLK Period		-200		+200	ppm	1
RCLK Pulse Width		100			ns	
RCLK Rise and Fall Times				50	ns	
RPOS, RNEG Setup to RCLK		50			ns	
RPOS, RNEG Hold for RCLK		50			ns	
Propagation delay from RRCLK to RPOS, RRNEG Valid				50	ns	
Propagation delay from XTAL OUT to RRCLK				50	ns	2
$\overline{\text{RST}}$ Pulse Width		1			$\mu\text{A}$	

**NOTES:**

1. The average period of RCLK must be within  $\pm 200$  ppm of the fundamental frequency of the crystal divided by four.
2. Only valid when the incoming jitter is less than 120 Ulpp (BDS=0) or 28 Ulpp (BDS=1).



## AC TIMING DIAGRAM Figure 5

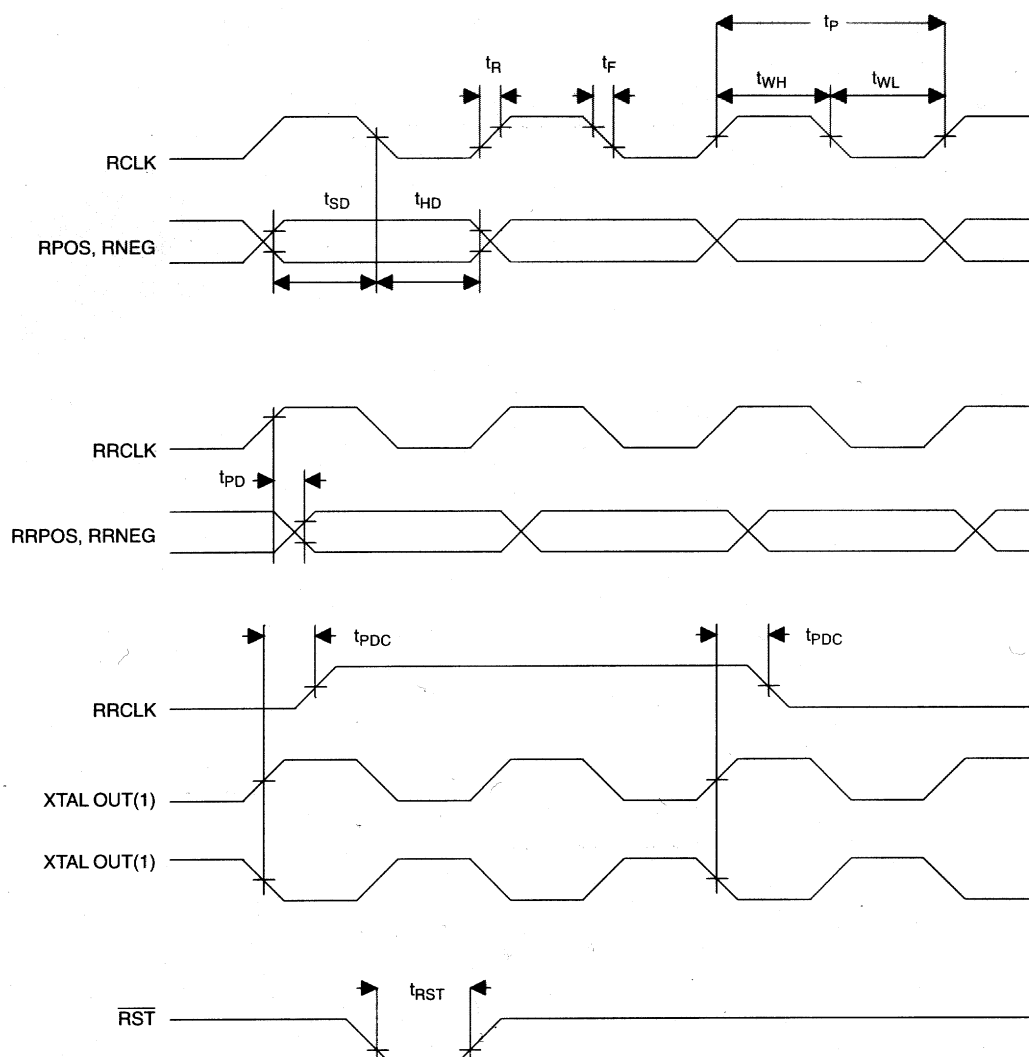

### NOTE:

1. The phase relationship between XTAL OUT and RRCLK can be of either form.

## DS1288 T1/CEPT JITTER ATTENUATOR 16-PIN DIP

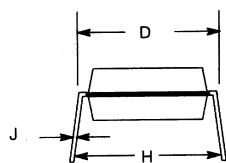
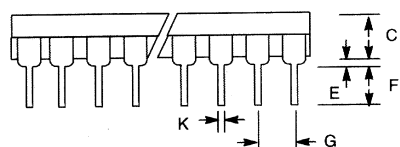
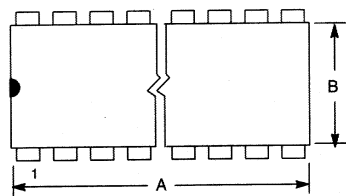

PKG	16-PIN	
DIM	MIN	MAX
A IN	0.740	0.780
MM	18.80	19.81
B IN	0.240	0.260
MM	6.10	6.60
C IN	0.120	0.140
MM	3.05	3.56
D IN	0.300	0.325
MM	7.62	8.26
E IN	0.015	0.040
MM	0.38	1.02
F IN	0.120	0.140
MM	3.04	1.02
G IN	0.090	0.110
MM	2.29	2.79
H IN	0.320	0.370
MM	8.13	9.40
J IN	0.008	0.012
MM	0.20	0.30
K IN	0.015	0.021
MM	0.38	0.53

## DS1288S T1/CEPT JITTER ATTENUATOR 16-PIN SOIC

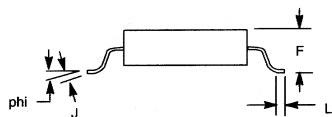
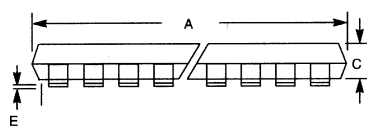
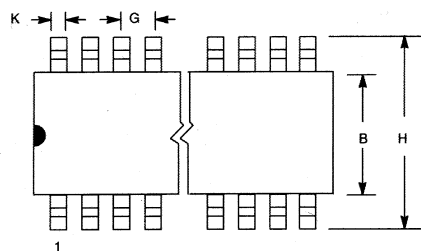

PKG	16-PIN	
DIM	MIN	MAX
AIN	0.402	0.412
MM	10.21	10.46
B IN	0.290	0.300
MM	7.37	7.65
C IN	0.089	0.095
MM	2.26	2.41
E IN	0.004	0.012
MM	0.102	0.30
F IN	0.094	0.105
MM	2.38	2.68
G IN	0.050 BSC	
MM	1.27 BSC	
H IN	0.398	0.416
MM	10.11	10.57
J IN	0.009	0.013
MM	0.229	0.33
K IN	0.013	0.019
MM	0.33	0.48
L IN	0.016	0.40
MM	0.40	1.02
phi	0°	8°