

February 1986

DS1628/DS3628 Octal TRI-STATE® MOS Drivers

General Description

The DS1628/DS3628 are octal Schottky memory drivers with TRI-STATE outputs designed to drive high capacitive loads associated with MOS memory systems. The drivers' output (V_{OH}) is specified at 3.4V to provide additional noise immunity required by MOS inputs. A PNP input structure is employed to minimize input currents. The circuit employs Schottky-clamped transistors for high speed. A NOR gate of two inputs, DIS1 and DIS2, controls the TRI-STATE mode.

Features

- High speed capabilities
 - Typical 5 ns driving 50 pF & 8 ns driving 500 pF
- TRI-STATE outputs
- High V_{OH} (3.4V min)
- High density
 - Eight drivers and two disable controls for TRI-STATE in a 20-pin package
- PNP inputs reduce DC loading on bus lines
- Glitch-free power up/down

Schematic and Connection Diagrams

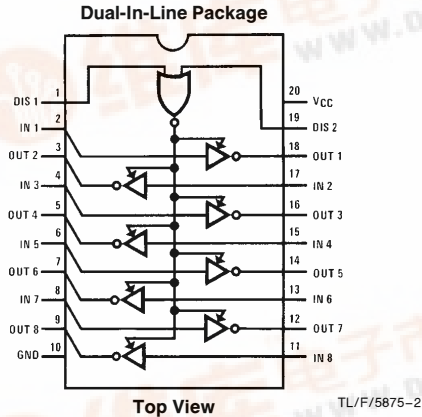
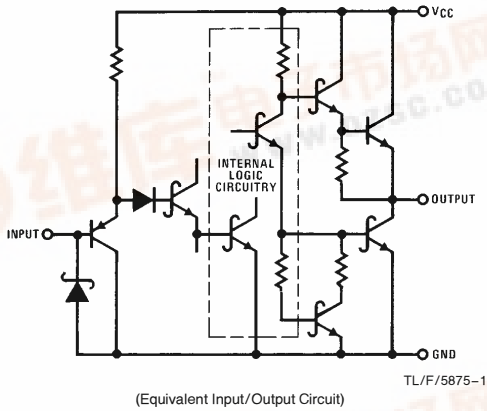

Order Number
DS1628J, DS3628J, DS3628N
See NS Package Number J20A or N20A

Truth Table

Disable Input		Input	Output
DIS 1	DIS 2		
H	H	X	Z
H	X	X	Z
X	H	X	Z
L	L	H	L
L	L	L	H

H = high level
L = low level
X = don't care
Z = high impedance (off)

Typical Application

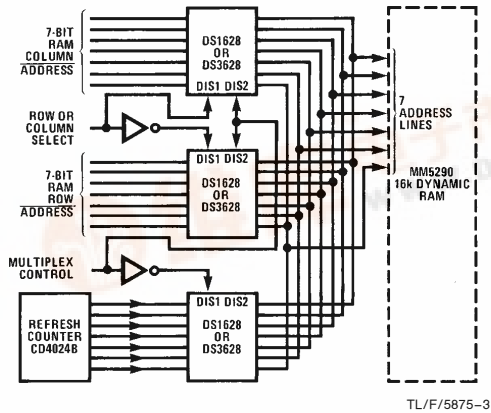

TRI-STATE® is a registered trademark of National Semiconductor Corp.

DS1628/DS3628 Octal TRI-STATE MOS Drivers



Absolute Maximum Ratings (Note 1)

If Military/Aerospace specified devices are required, please contact the National Semiconductor Sales Office/Distributors for availability and specifications.

Supply Voltage	7.0V
Logical "1" Input Voltage	7.0V
Logical "0" Input Voltage	-1.5V
Storage Temperature Range	-65°C to +150°C
Maximum Power Dissipation* at 25°C	
Cavity Package	1667 mW
Molded Package	1832 mW
Lead Temperature (Soldering, 10 seconds)	300°C

*Derate cavity package 11.1 mW/°C above 25°C; derate molded package 14.7 mW/°C above 25°C.

Operating Conditions

	Min	Max	Units
Supply voltage (V_{CC})	4.5	5.5	V
Temperature (T_A)			
DS1628	-55	+125	°C
DS3628	0	+70	°C

Electrical Characteristics (Notes 2, 3)

Symbol	Parameter	Conditions	Min	Typ	Max	Units	
$V_{IN(1)}$	Logical "1" Input Voltage		2.0			V	
$V_{IN(0)}$	Logical "0" Input Voltage				0.8	V	
$I_{IN(1)}$	Logical "1" Input Current	$V_{CC} = 5.5V$ $V_{IN} = 5.5V$		0.1	40	μA	
$I_{IN(0)}$	Logical "0" Input Current	$V_{CC} = 5.5V$ $V_{IN} = 5.5V$		-180	-400	μA	
V_{CLAMP}	Input Clamp Voltage	$V_{CC} = 4.5V$ $I_{IN} = -18 \mu A$		-0.7	-1.2	V	
V_{OH}	Logical "1" Output Voltage (No Load)	$V_{CC} = 4.5V$, $I_{OH} = -10 \mu A$	DS1628	3.4	4.3		V
			DS3628	3.5	4.3		V
V_{OL}	Logical "0" Output Voltage (No Load)	$V_{CC} = 4.5V$, $I_{OL} = 10 \mu A$	DS1628		0.25	0.4	V
			DS3628		0.25	0.35	V
V_{OH}	Logical "1" Output Voltage (With Load)	$V_{CC} = 4.5V$, $I_{OH} = -1.0 \text{ mA}$	DS1628	2.5	3.9		V
			DS3628	2.7	3.9		V
V_{OL}	Logical "0" Output Voltage (With Load)	$V_{CC} = 4.5V$, $I_{OL} = 20 \text{ mA}$	DS1628/DS3628		0.35	0.5	V
I_{ID}	Logical "1" Drive Current	$V_{CC} = 4.5V$, $V_{OUT} = 0V$, (Note 6)		-150		mA	
I_{OD}	Logical "0" Drive Current	$V_{CC} = 4.5V$, $V_{OUT} = 4.5V$, (Note 6)		150		mA	
Hi-Z	TRI-STATE Output Current	$V_{OUT} = 0.4V$ to $2.4V$, DIS1 or DIS2 = 2.0V	-40	0.1	40	μA	
I_{CC}	Power Supply Current	$V_{CC} = 5.5V$ One DIS Input = 3.0V All Other Inputs = X, Outputs at Hi-Z		90	120	mA	
				70	100	mA	
				25	50	mA	

Switching Characteristics ($V_{CC} = 5V$, $T_A = 25^\circ C$) (Note 6)

Symbol	Parameter	Conditions	Min	Typ	Max	Units
t_{S-}	Storage Delay Negative Edge	(Figure 1) $C_L = 50 \text{ pF}$		4.0	5.0	ns
		$C_L = 500 \text{ pF}$		6.5	8.0	
t_{S+}	Storage Delay Positive Edge	(Figure 1) $C_L = 50 \text{ pF}$		4.2	5.0	ns
		$C_L = 500 \text{ pF}$		6.5	8.0	
t_F	Fall Time	(Figure 1) $C_L = 50 \text{ pF}$		4.2	6.0	ns
		$C_L = 500 \text{ pF}$		19	22	
t_R	Rise Time	(Figure 1) $C_L = 50 \text{ pF}$		5.2	7.0	ns
		$C_L = 500 \text{ pF}$		20	24	
t_{ZL}	Delay from Disable Input to Logical "0" Level (from High Impedance State)	$C_L = 50 \text{ pF}$ $R_L = 2 \text{ k}\Omega$ to V_{CC} (Figure 2)		19	25	ns
t_{ZH}	Delay from Disable Input to Logical "1" Level (from High Impedance State)	$C_L = 50 \text{ pF}$ $R_L = 2 \text{ k}\Omega$ to GND (Figure 2)		13	20	ns

Switching Characteristics (Continued) ($V_{CC} = 5V$, $T_A = 25^\circ C$) (Note 6)

Symbol	Parameter	Conditions	Min	Typ	Max	Units
t_{LZ}	Delay from Disable Input to High Impedance State (from Logical "0" Level)	$C_L = 50\text{ pF}$ $R_L = 400\Omega$ to V_{CC} (Figure 3)		18	25	ns
t_{HZ}	Delay from Disable Input to High Impedance State (from Logical "1" Level)	$C_L = 50\text{ pF}$ $R_L = 400\Omega$ to GND (Figure 3)		8.5	15	ns

AC Test Circuits and Switching Time Waveforms

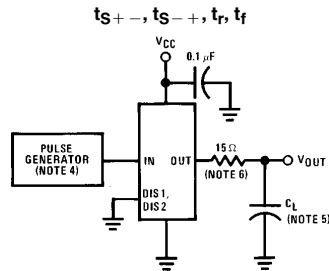

TL/F/5875-4

FIGURE 1

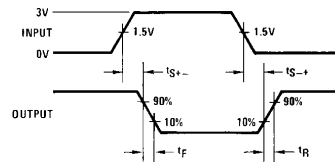

TL/F/5875-5

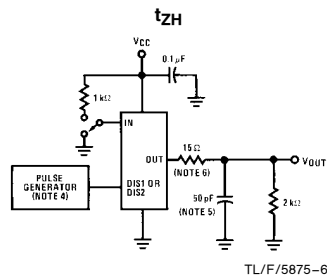

TL/F/5875-6

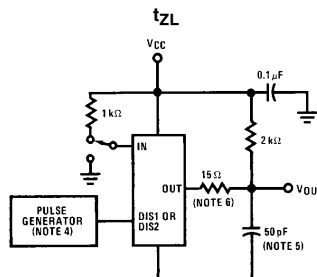

TL/F/5875-7

FIGURE 2

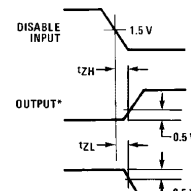

TL/F/5875-8

*ANY ONE OF EIGHT OUTPUTS

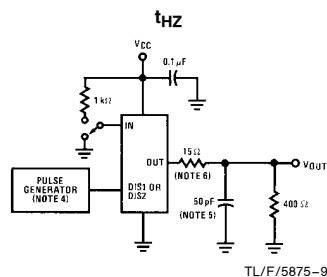

TL/F/5875-9

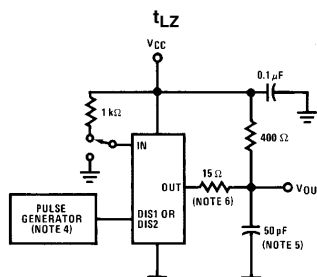

TL/F/5875-10

FIGURE 3

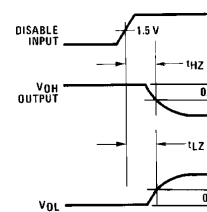

TL/F/5875-11

Note 1: "Absolute Maximum Ratings" are those values beyond which the safety of the device cannot be guaranteed. Except for "Operating Temperature Range" they are not meant to imply that the devices should be operated at these limits. The table of "Electrical Characteristics" provides conditions for actual device operation.

Note 2: Unless otherwise specified, min/max limits apply across the $-55^\circ C$ to $+125^\circ C$ temperature range for the DS1628 and across the $0^\circ C$ to $+70^\circ C$ range for the DS3628. All typical values are for $T_A = 25^\circ C$ and $V_{CC} = 5V$.

Note 3: All currents into device pins shown as positive; all currents out of device pins shown as negative; all voltages references to ground unless otherwise noted. All values shown as max or min on absolute value basis.

Note 4: The pulse generator has the following characteristics: $Z_{OUT} = 50\Omega$ and $PRR \leq 1\text{ MHz}$. Rise and fall times between 10% and 90% points $\leq 5\text{ ns}$.

Note 5: C_L includes probe and jig capacitance.

Note 6: When measuring output drive current and switching response for the DS1628 and DS3628 a 15Ω resistor should be placed in series with each output.

Physical Dimensions inches (millimeters)

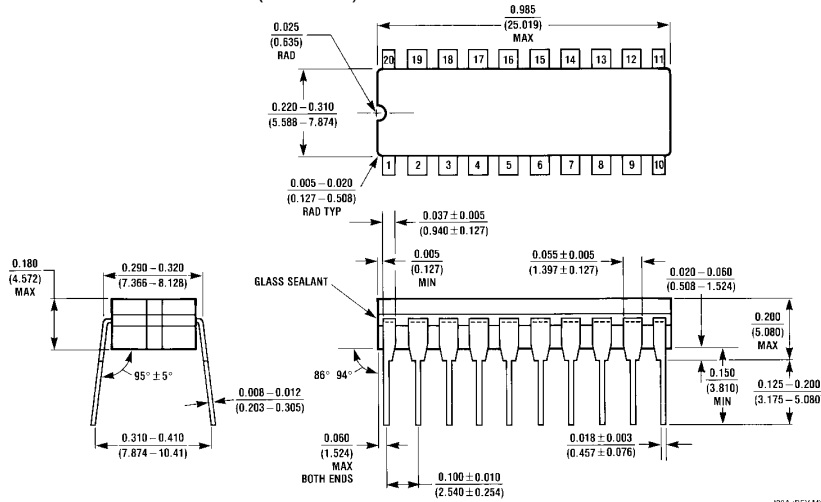

Ceramic Dual-In-Line Package (J)
Order Number DS1628J or DS3628J
NS Package Number J20A

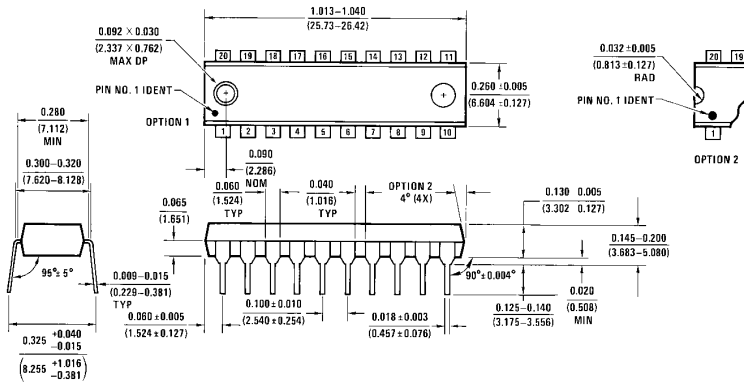

Molded Dual-In-Line Package (N)
Order Number DS3628N
NS Package Number N20A

LIFE SUPPORT POLICY

NATIONAL'S PRODUCTS ARE NOT AUTHORIZED FOR USE AS CRITICAL COMPONENTS IN LIFE SUPPORT DEVICES OR SYSTEMS WITHOUT THE EXPRESS WRITTEN APPROVAL OF THE PRESIDENT OF NATIONAL SEMICONDUCTOR CORPORATION. As used herein:

1. Life support devices or systems are devices or systems which, (a) are intended for surgical implant into the body, or (b) support or sustain life, and whose failure to perform, when properly used in accordance with instructions for use provided in the labeling, can be reasonably expected to result in a significant injury to the user.
2. A critical component is any component of a life support device or system whose failure to perform can be reasonably expected to cause the failure of the life support device or system, or to affect its safety or effectiveness.

National Semiconductor Corporation
 1111 West Bardin Road
 Arlington, TX 76017
 Tel: 1(800) 272-9959
 Fax: 1(800) 737-7018

National Semiconductor Europe
 Fax: (+49) 0-180-530 85 86
 Email: cnjwge@tevm2.nsc.com
 Deutsch Tel: (+49) 0-180-530 85 85
 English Tel: (+49) 0-180-532 78 32
 Français Tel: (+49) 0-180-532 93 58
 Italiano Tel: (+49) 0-180-534 16 80

National Semiconductor Hong Kong Ltd.
 13th Floor, Straight Block,
 Ocean Centre, 5 Canton Rd.
 Tsimshatsui, Kowloon
 Hong Kong
 Tel: (852) 2737-1600
 Fax: (852) 2736-9960

National Semiconductor Japan Ltd.
 Tel: 81-043-299-2309
 Fax: 81-043-299-2408