



Low Cost Two-Way SMT Power Divider 824-960 MHz



Features

- Small Size and Low Profile
- Industry Standard SOIC-8 SMT Plastic Package
- Excellent Amplitude and Phase Balance
- Superior Repeatability
- Typical Insertion Loss 0.5 dB
- Typical Isolation 23 dB
- 1 Watt Power Handling

Description

M/A-COM's DS52-0001 is an IC-based monolithic power divider in a low cost SOIC-8 plastic package. This 2-way power divider is ideally suited for applications where small size, low insertion loss, superior phase/amplitude tracking and low cost are required. Typical applications include base station switching networks and other communication applications where size and PCB real estate are a premium. Available in tape and reel.

The DS52-0001 is fabricated using a passive-integrated circuit process. The process features full-chip passivation for increased performance and reliability.

SOIC-8

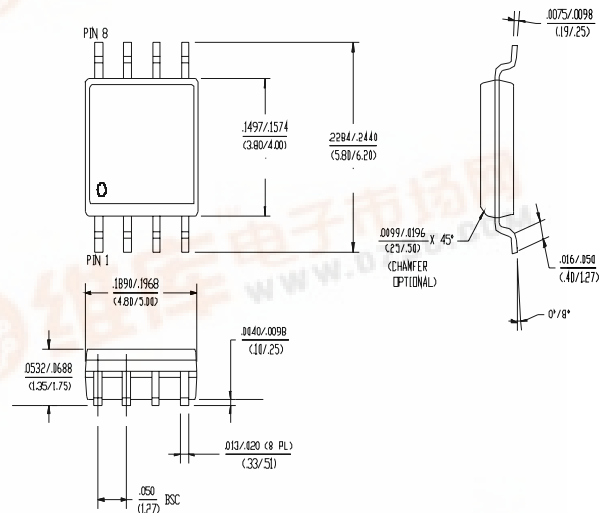

Ordering Information

Part Number	Package
DS52-0001	SOIC-8 Lead Plastic Package
DS52-0001-TR	Forward Tape and Reel ¹
DS52-0001-RTR	Reverse Tape and Reel ¹

1. If specific reel size is required, consult factory for part number assignment.

Typical Electrical Specifications¹, T_A = +25°C

Parameter	Units	Min	Typ	Max
Insertion Loss Above 3.0dB	dB	—	0.5	0.6
Isolation	dB	15	23	—
VSWR	—	—	1.2:1	1.4:1
Amplitude Balance	dB	—	0.05	0.15
Phase Balance	°	—	0.5	1.5

1. All specifications apply with a 50-Ohm source and load impedance.



Absolute Maximum Ratings¹

Parameter	Absolute Maximum
Input Power ²	1 W CW
Operating Temperature	-40°C to +85°C
Storage Temperature	-65°C to +150°C

1. Exceeding these limits may cause permanent damage.
2. With Internal load dissipation of 0.125 W maximum.

Recommended PCB Configuration

(Dimensions in Inches)

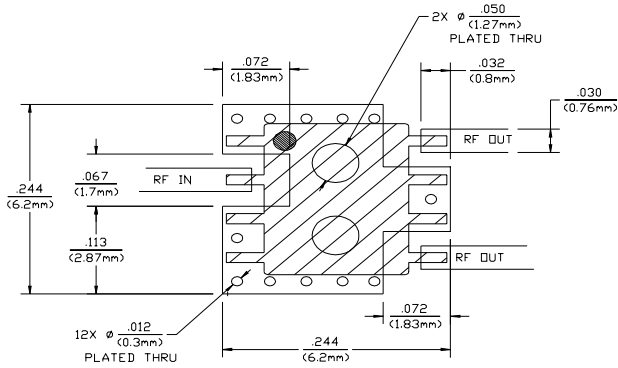

DS52-0001 PCB LAYOUT (SDIC-8 CASE)
SCALE: 1X
CIRCUIT MATERIAL: FR-4, .016 THICK
ALL RF PORTS ARE 50 OHMS

Functional Diagram³

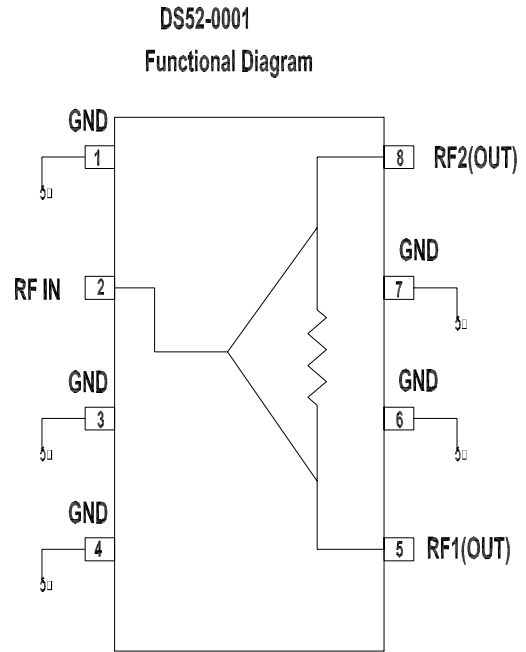

Pins 1, 3, 4, 6 and 7 must be DC and RF grounded

Typical Performance @ +25°C

