

Absolute Maximum Ratings¹

Parameter	Absolute Maximum
Input Power ²	1W CW
Operating Temperature	-40°C to +85°C
Storage Temperature	-65°C to 150°C

1. Exceeding these limits may cause permanent damage.
2. With internal load dissipation of 0.125 W maximum.

Recommended PCB Configuration

(Dimensions in Inches)
mm

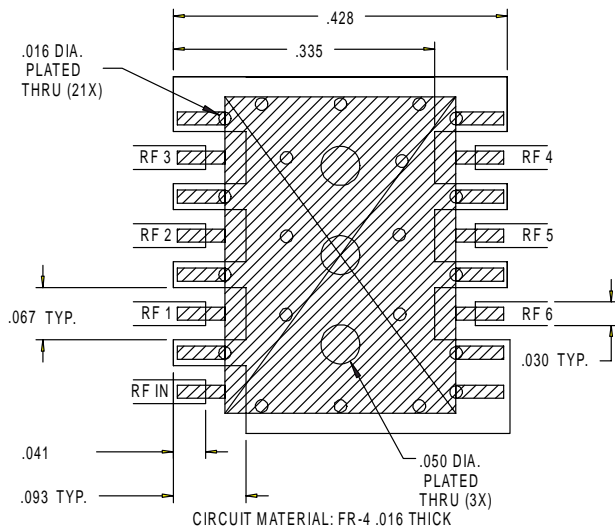

Functional Diagram³

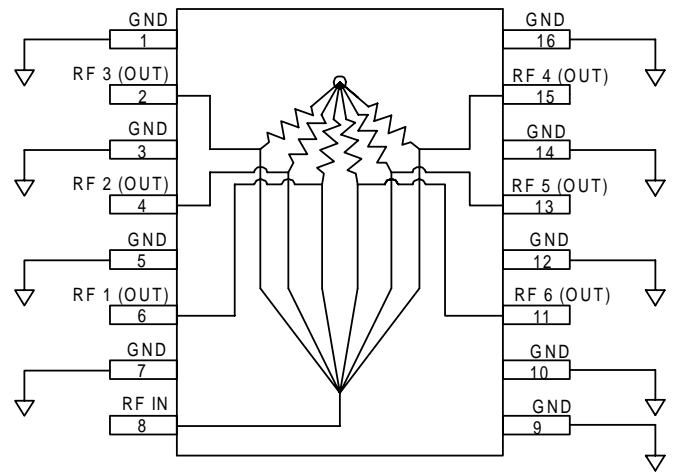

3. Pins 1, 3, 5, 7, 9, 10, 12, 14 and 16 must be DC and RF grounded.

Typical Performance @ +25°C

