



May 1999

DS75160A/DS75161A IEEE-488 GPIB Transceivers

General Description

This family of high-speed-Schottky 8-channel bi-directional transceivers is designed to interface TTL/MOS logic to the IEEE Standard 488-1978 General Purpose Interface Bus (GPIB). PNP inputs are used at all driver inputs for minimum loading, and hysteresis is provided at all receiver inputs for added noise margin. The IEEE-488 required bus termination is provided internally with an active turn-off feature which disconnects the termination from the bus when V_{CC} is removed. The General Purpose Interface Bus is comprised of 16 signal lines — 8 for data and 8 for interface management. The data lines are always implemented with DS75160A, and the management lines are either implemented with DS75161A in a single-controller system.

Features

- 8-channel bi-directional non-inverting transceivers
- Bi-directional control implemented with TRI-STATE® output design
- Meets IEEE Standard 488-1978
- High-speed Schottky design
- Low power consumption
- High impedance PNP inputs (drivers)
- 500 mV (typ) input hysteresis (receivers)
- On-chip bus terminators
- No bus loading when V_{CC} is removed
- Pin selectable open collector mode on DS75160A driver outputs
- Accommodates multi-controller systems

Connection Diagrams

Dual-In-Line Package

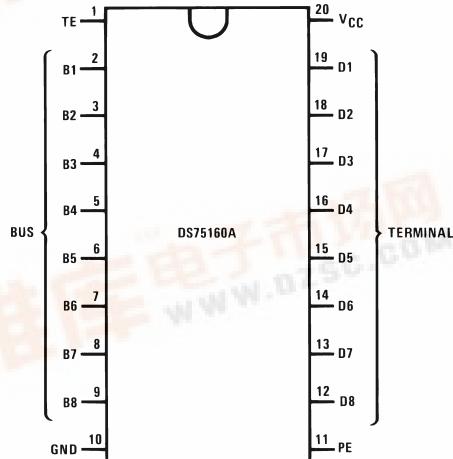

DS005804-1

Top View
Order Number DS75160AN or DS75160AWM
See NS Package Number M20B or N20A

Dual-In-Line Package

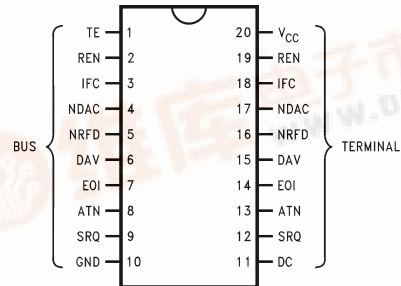

DS005804-16

Order Number DS75161AN or DS75161AWM
See NS Package Number M20B or N20B



Absolute Maximum Ratings (Note 2)

If Military/Aerospace specified devices are required, please contact the National Semiconductor Sales Office/Distributors for availability and specifications.

Supply Voltage, V_{CC}	7.0V
Input Voltage	5.5V
Storage Temperature Range	-65°C to +150°C
Lead Temperature (Soldering, 4 sec.)	260°C
Maximum Power Dissipation (Note 1) at 25°C	

Molded Package

1897 mW

	Min	Max	Units
V_{CC} , Supply Voltage	4.75	5.25	V
T_A , Ambient Temperature	0	70	°C
I_{OL} , Output Low Current			
Bus		48	mA
Terminal		16	mA

Note 1: Derate molded package 15.2 mW/°C above 25°C.

Electrical Characteristics (Notes 3, 4)

Symbol	Parameter	Conditions	Min	Typ	Max	Units	
V_{IH}	High-Level Input Voltage		2			V	
V_{IL}	Low-Level Input Voltage				0.8	V	
V_{IK}	Input Clamp Voltage	$I_I = -18$ mA		-0.8	-1.5	V	
V_{HYS}	Input Hysteresis	Bus	400	500		mV	
V_{OH}	High-Level Output Voltage	Terminal $I_{OH} = -800$ μ A	2.7	3.5		V	
	Bus (Note 4)	$I_{OH} = -5.2$ mA	2.5	3.4			
V_{OL}	Low-Level Output Voltage	Terminal $I_{OL} = 16$ mA		0.3	0.5	V	
	Bus	$I_{OH} = 48$ mA		0.4	0.5		
I_{IH}	High-Level Input Current	Terminal and TE, PE, DC, SC Inputs	$V_I = 5.5$ V	0.2	100	μ A	
I_{IL}	Low-Level Input Current		$V_I = 2.7$ V	0.1	20		
I_{IL}	Low-Level Input Current		$V_I = 0.5$ V	-10	-100	μ A	
V_{BIAS}	Terminator Bias Voltage at Bus Port	Driver Disabled	$I_{I(bus)} = 0$ (No Load)	2.5	3.0	3.7	V
I_{LOAD}	Terminator Bus Loading Current	Bus	Driver Disabled	$V_{I(bus)} = -1.5$ V to 0.4V	-1.3		
			Driver Disabled	$V_{I(bus)} = 0.4$ V to 2.5V	0		-3.2
			Driver Disabled	$V_{I(bus)} = 2.5$ V to 3.7V			2.5
			Driver Disabled	$V_{I(bus)} = 3.7$ V to 5V			-3.2
			Driver Disabled	$V_{I(bus)} = 5$ V to 5.5V	0.7		2.5
			$V_{CC} = 0$ V, $V_{I(bus)} = 0$ V to 2.5V			40	μ A
I_{OS}	Short-Circuit Output Current	Terminal	$V_I = 2$ V, $V_O = 0$ V (Note 5)	-15	-35	-75	mA
		Bus (Note 6)		-35	-75	-150	
I_{CC}	Supply Current	DS75160A	Transmit, TE = 2V, PE = 2V, $V_I = 0.8$ V		85	125	mA
			Receive, TE = 0.8V, PE = 2V, $V_I = 0.8$ V		70	100	
		DS75161A	TE = 0.8V, DC = 0.8V, $V_I = 0.8$ V		84	125	
C_{IN}	Bus-Port Capacitance	Bus	$V_{CC} = 5$ V or 0V, $V_I = 0$ V to 2V, $f = 1$ MHz		20	30	pF

Note 2: "Absolute Maximum Ratings" are those values beyond which the safety of the device cannot be guaranteed. They are not meant to imply that the device should be operated at these limits. The table of "Electrical Characteristics" provides conditions for actual device operation.

Note 3: Unless otherwise specified, min/max limits apply across the 0°C to +70°C temperature range and the 4.75V to 5.25V power supply range. All typical values are for $T_A = 25$ °C and $V_{CC} = 5.0$ V.

Note 4: All currents into device pins are shown as positive; all currents out of device pins are shown as negative; all voltages are referenced to ground, unless otherwise specified. All values shown as max or min are so classified on absolute value basis.

Note 5: Only one output at a time should be shorted.

Note 6: This characteristic does not apply to outputs on DS75161A that are open collector.

Switching Characteristics (Note 7)

$V_{CC} = 5.0V \pm 5\%$, $T_A = 0^\circ C$ to $70^\circ C$

Symbol	Parameter	From	To	Conditions	DS75160A			DS75161A			DS75162A			Units		
					Min	Typ	Max	Min	Typ	Max	Min	Typ	Max			
t_{PLH}	Propagation Delay Time, Low to High Level Output	Terminal	Bus	$V_L = 2.3V$ $R_L = 38.3\Omega$		10	20		10	20		10	20	ns		
t_{PHL}	Propagation Delay Time, High to Low Level Output					$C_L = 30\text{ pF}$ <i>Figure 1</i>		14	20		14	20		14	20	ns
t_{PLH}	Propagation Delay Time, Low to High Level Output	Bus	Terminal	$V_L = 5.0V$ $R_L = 240\Omega$		14	20		14	20		14	20	ns		
t_{PHL}	Propagation Delay Time, High to Low Level Output					$C_L = 30\text{ pF}$ <i>Figure 2</i>		10	20		10	20		10	20	ns
t_{PZH}	Output Enable Time to High Level	TE, DC, or SC (Note 8) (Note 9)	Bus	$V_I = 3.0V$ $V_L = 0V$ $R_L = 480\Omega$ $C_L = 15\text{ pF}$ <i>Figure 1</i>		19	32		23	40		23	40	ns		
t_{PHZ}	Output Disable Time From High Level							15	22		15	25		15	25	ns
t_{PZL}	Output Enable Time to Low Level					$V_I = 0V$ $V_L = 2.3V$ $R_L = 38.3\Omega$ $C_L = 15\text{ pF}$ <i>Figure 1</i>		24	35		28	48		28	48	ns
t_{PLZ}	Output Disable Time From Low Level							17	25		17	27		17	27	ns
t_{PZH}	Output Enable Time to High Level	TE, DC, or SC (Note 8) (Note 9)	Terminal	$V_I = 3.0V$ $V_L = 0V$ $R_L = 3\text{ k}\Omega$ $C_L = 15\text{ pF}$ <i>Figure 1</i>		17	33		18	40		18	40	ns		
t_{PHZ}	Output Disable Time From High Level							15	25		22	33		22	33	ns
t_{PZL}	Output Enable Time to Low Level					$V_I = 0V$ $V_L = 5V$ $R_L = 280\Omega$ $C_L = 15\text{ pF}$ <i>Figure 1</i>		25	39		28	52		28	52	ns
t_{PLZ}	Output Disable Time From Low Level							15	27		20	35		20	35	ns
t_{PZH}	Output Pull-Up Enable Time (DS75160A Only)	PE (Note 8)	Bus	$V_I = 3V$ $V_L = 0V$		10	17		NA			NA		ns		
t_{PHZ}	Output Pull-Up Disable Time (DS75160A Only)					$R_L = 480\Omega$ $C_L = 15\text{ pF}$ <i>Figure 1</i>		10	15		NA			NA		ns

Note 7: Typical values are for $V_{CC} = 5.0V$ and $T_A = 25^\circ C$ and are meant for reference only.

Note 8: Refer to Functional Truth Tables for control input definition.

Note 9: Test configuration should be connected to only one transceiver at a time due to the high current stress caused by the V_I voltage source when the output connected to that input becomes active.

Switching Load Configurations

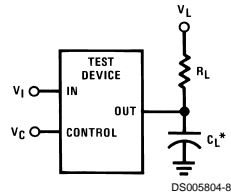

V_C logic high = 3.0V
 V_C logic low = 0V
 * C_L includes jig and probe capacitance

FIGURE 1.

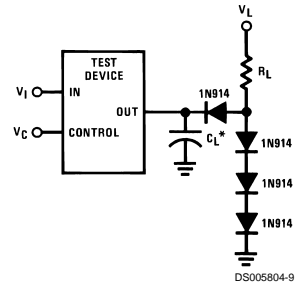

V_C logic high = 3.0V
 V_C logic low = 0V
 * C_L includes jig and probe capacitance

FIGURE 2.

Connection Diagrams

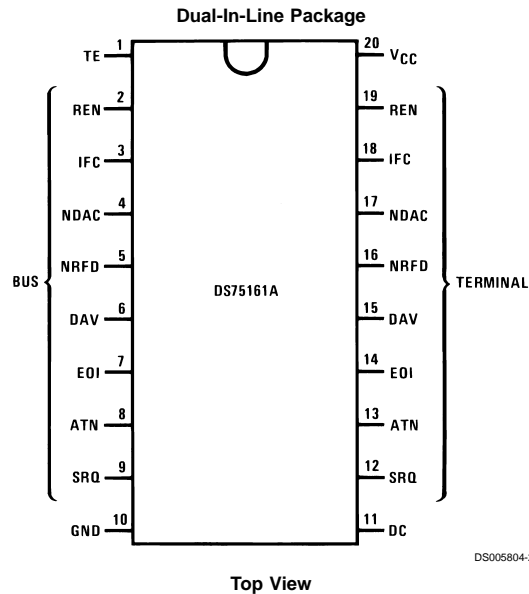

DS005804-2

Functional Description

DS75160A

This device is an 8-channel bi-directional transceiver with one common direction control input, denoted TE. When used to implement the IEEE-488 bus, this device is connected to the eight data bus lines, designated DIO_1 – DIO_8 . The port connections to the bus lines have internal terminators, in accordance with the IEEE-488 Standard, that are deactivated when the device is powered down. This feature guarantees no bus loading when $V_{CC} = 0V$. The bus port outputs also have a control mode that either enables or disables the active upper stage of the totem-pole configuration. When this control input, denoted PE, is in the high state, the bus outputs operate in the high-speed totem-pole mode. When PE is in the low state, the bus outputs operate as open collector outputs which are necessary for parallel polling.

DS75161A

This device is also an 8-channel bi-directional transceiver which is specifically configured to implement the eight management signal lines of the IEEE-488 bus. This device, paired with the DS75160A, forms the complete 16-line interface between the IEEE-488 bus and a single controller instrumentation system. In compliance with the system organization of the management signal lines, the SRQ, NDAC, and NRFD bus port outputs are open collector. In contrast to the DS75160A, these open collector outputs are a fixed configuration. The direction control is divided into three groups. The DAV, NDAC, and NRFD transceiver directions are controlled by the TE input. The ATN, SRQ, REN, and IFC transceiver directions are controlled by the DC input. The EOI transceiver direction is a function of both the TE and DC inputs, as well as the logic level present on the ATN channel. The port connections to the bus lines have internal terminators identical to the DS75160A.

Functional Description (Continued)

Table of Signal Line Abbreviations

Signal Line Classification	Mnemonic	Definition	Device
Control Signals	DC	Direction Control	DS75161A
	PE	Pull-Up Enable	DS75160A
	TE	Talk Enable	All
Data I/O Ports	SC	System Controller	
	B1–B8	Bus Side of Device	DS75160A
D1–D8	Terminal Side of Device		
Management Signals	ATN	Attention	DS75161A
	DAV	Data Valid	
	EOI	End or Identify	
	IFC	Interface Clear	
	NDAC	Not Data Accepted	
	NRFD	Not Ready for Data	
	REN	Remote Enable	
SRQ	Service Request		

Logic Diagrams

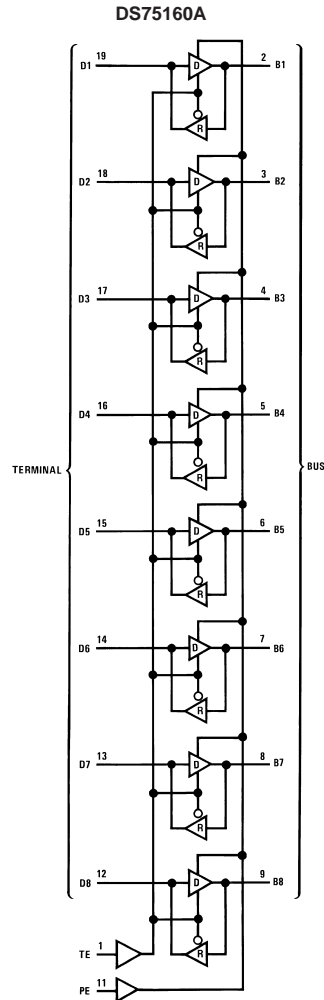

Note 1:  Denotes driver

Note 2:  Denotes receiver

Note 3: Driver and receiver outputs are totem-pole configurations

Note 4: The driver outputs of DS75160A can have their active pull-ups disabled by switching the PE input (pin 11) to the logic low state. This mode configures the outputs as open collector.

DS005804-4

Logic Diagrams (Continued)

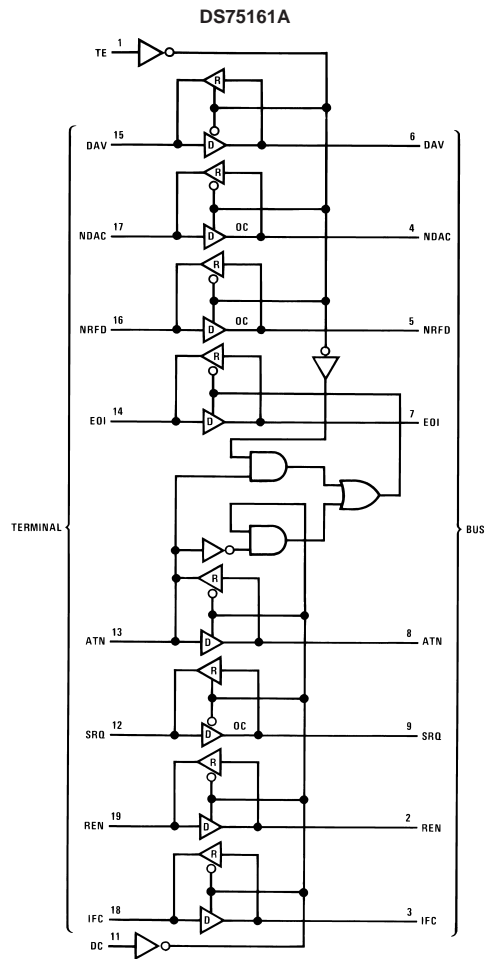

Note 1:  Denotes driver

Note 2:  Denotes receiver

Note 3: Symbol "OC" specifies open collector output

Note 4: Driver and receiver outputs that are not specified "OC" are totem-pole configurations

DS005804-7

Switching Waveforms

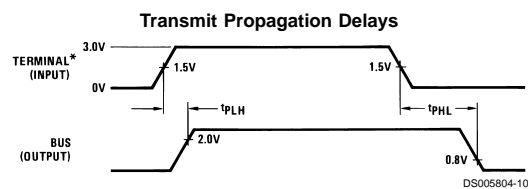

Switching Waveforms (Continued)

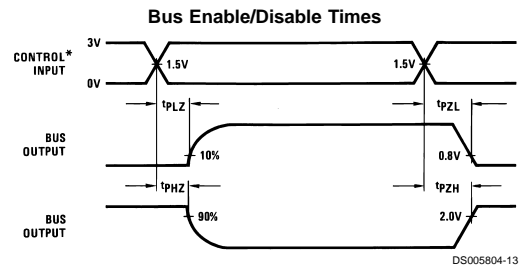
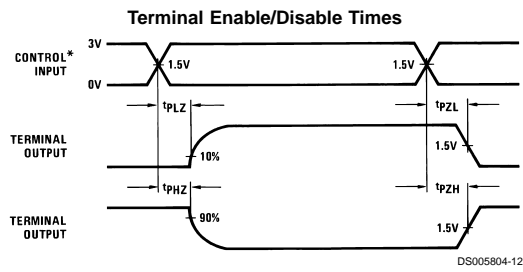
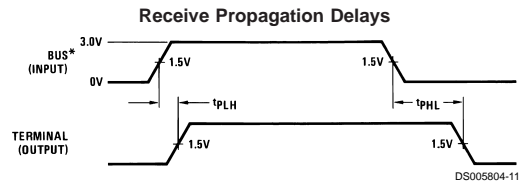

*Input signal: $f = 1.0 \text{ MHz}$, 50% duty cycle, $t_r = t_f \leq 5 \text{ ns}$

Performance Characteristics

Bus Port Load Characteristics

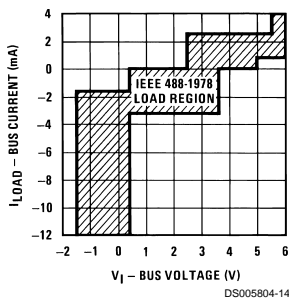

Refer to Electrical Characteristics table

Functional Truth Tables

DS75160A

Control Input Level		Data Transceivers	
TE	PE	Direction	Bus Port Configuration
H	H	T	Totem-Pole Output
H	L	T	Open Collector Output
L	X	R	Input

DS75161A

Control Input Level			Transceiver Signal Direction							
TE	DC	ATN*	EOI	REN	IFC	SRQ	NRFD	NDAC	DAV	
H	H	R		R	R	T	R	R	T	
H	L	T		T	T	R	R	R	T	
L	H	R		R	R	T	T	T	R	
L	L	T		T	T	R	T	T	R	
H	X	H		T						
L	X	H		R						
X	H	L		R						
X	L	L		T						

H = High level input

L = Low level input

X = Don't care

T = Transmit, i.e., signal outputted to bus

R = Receive, i.e., signal outputted to terminal

*The ATN signal level is sensed for internal multiplex control of EOI transmission direction logic.

Physical Dimensions inches (millimeters) unless otherwise noted

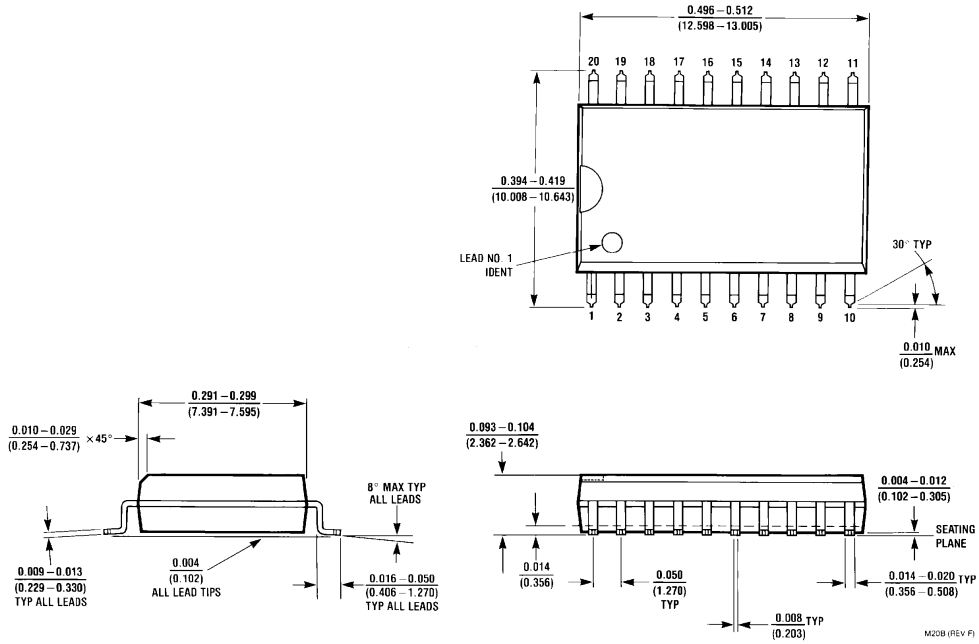

Order Number DS75160AWM
NS Package Number M20B

M20B (REV F)

Physical Dimensions inches (millimeters) unless otherwise noted (Continued)

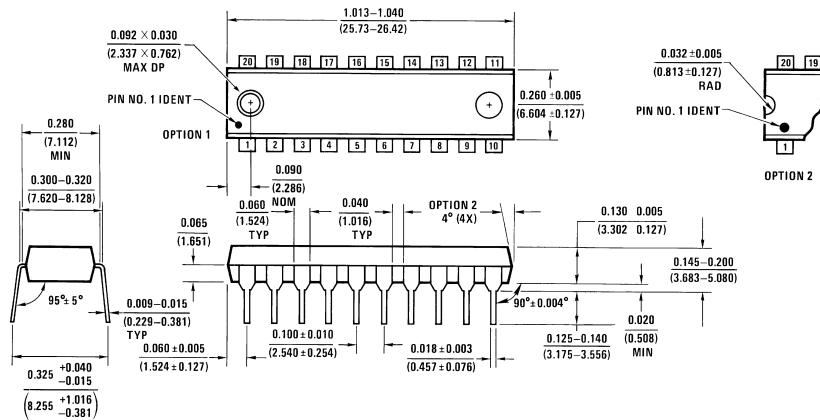

Molded Dual-In-Line Package (N)
Order Number DS75160AN or DS75161AN
NS Package Number N20A

LIFE SUPPORT POLICY

NATIONAL'S PRODUCTS ARE NOT AUTHORIZED FOR USE AS CRITICAL COMPONENTS IN LIFE SUPPORT DEVICES OR SYSTEMS WITHOUT THE EXPRESS WRITTEN APPROVAL OF THE PRESIDENT AND GENERAL COUNSEL OF NATIONAL SEMICONDUCTOR CORPORATION. As used herein:

1. Life support devices or systems are devices or systems which, (a) are intended for surgical implant into the body, or (b) support or sustain life, and whose failure to perform when properly used in accordance with instructions for use provided in the labeling, can be reasonably expected to result in a significant injury to the user.
2. A critical component is any component of a life support device or system whose failure to perform can be reasonably expected to cause the failure of the life support device or system, or to affect its safety or effectiveness.

 **National Semiconductor Corporation**
 Americas
 Tel: 1-800-272-9959
 Fax: 1-800-737-7018
 Email: support@nsc.com

National Semiconductor Europe
 Fax: +49 (0) 1 80-530 85 86
 Email: europe.support@nsc.com
 Deutsch Tel: +49 (0) 1 80-530 85 85
 English Tel: +49 (0) 1 80-532 78 32
 Français Tel: +49 (0) 1 80-532 93 58
 Italiano Tel: +49 (0) 1 80-534 16 80

National Semiconductor Asia Pacific Customer Response Group
 Tel: 65-2544466
 Fax: 65-2504466
 Email: sea.support@nsc.com

National Semiconductor Japan Ltd.
 Tel: 81-3-5639-7560
 Fax: 81-3-5639-7507

www.national.com