



February 1996

## DS7837/DS8837 Hex Unified Bus Receiver

### General Description

The DS7837/DS8837 are high speed receivers designed for use in bus organized data transmission systems interconnected by terminated 120Ω impedance lines. The external termination is intended to be 180Ω resistor from the bus to the +5V logic supply together with a 390Ω resistor from the bus to ground. The receiver design employs a built-in input hysteresis providing substantial noise immunity. Low input current allows up to 27 driver/receiver pairs to utilize a common bus. Disable inputs provide time discrimination. Disable inputs and receiver outputs are TTL compatible. Performance is optimized for systems with bus rise and fall times  $\leq 1.0 \mu\text{s/V}$ .

### Features

- Low receiver input current for normal  $V_{CC}$  or  $V_{CC} = 0V$  (15  $\mu\text{A}$  typ)
- Six separate receivers per package
- Built-in receiver input hysteresis (1V typ)
- High receiver noise immunity (2V typ)
- Temperature insensitive receiver input thresholds track bus logic levels
- TTL compatible disable and output
- Molded or cavity dual-in-line or flat package
- High speed

### Typical Application

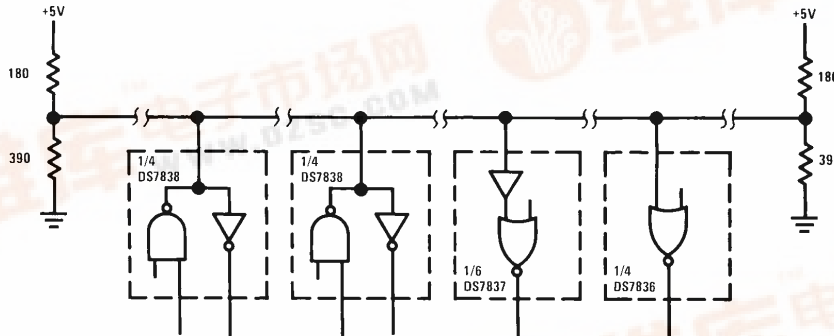

TL/F/5811-1

### Connection Diagram

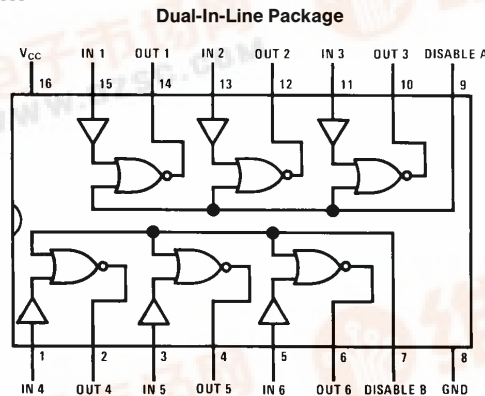

TL/F/5811-2

Top View

Order Number DS7837J, DS8837M or DS8837N  
See NS Package Number J16A, M16A or N16A

DS7837/DS8837 Hex Unified Bus Receiver



## Absolute Maximum Ratings (Note 1)

If Military/Aerospace specified devices are required, please contact the National Semiconductor Sales Office/Distributors for availability and specifications.

Supply Voltage	7V
Input Voltage	5.5V
Operating Temperature Range	
DS7837	-55°C to +125°C
DS8837	0°C to +70°C
Storage Temperature Range	-65°C to +150°C
Maximum Power Dissipation* at 25°C	
Cavity Package	1433 mW
Molded DIP Package	1362 mW
SO Package	1002 mW
Lead Temperature (Soldering, 4 seconds)	260°C

\*Derate cavity package 9.6 mW/°C above 25°C; derate molded DIP package 10.9 mW/°C above 25°C; derate SO package 8.01 mW/°C above 25°C.

## Operating Conditions

	Min	Max	Units
Supply Voltage, (V <sub>CC</sub> )			
DS7837	4.5	5.5	V
DS8837	4.75	5.25	V
Temperature (T <sub>A</sub> )			
DS7837	-55	+125	°C
DS8837	0	+70	°C

## Electrical Characteristics

The following apply for V<sub>MIN</sub> ≤ V<sub>CC</sub> ≤ V<sub>MAX</sub>, T<sub>MIN</sub> ≤ T<sub>A</sub> ≤ T<sub>MAX</sub>, unless otherwise specified (Notes 2 and 3)

Symbol	Parameter	Conditions	Min	Typ	Max	Units	
V <sub>TH</sub>	High Level Receiver Threshold	V <sub>CC</sub> = Max	DS7837	1.65	2.25	2.65	V
			DS8837	1.80	2.25	2.50	V
V <sub>TL</sub>	Low Level Receiver Threshold	V <sub>CC</sub> = Min	DS7837	0.97	1.30	1.63	V
			DS8837	1.05	1.30	1.55	V
I <sub>IH</sub>	Maximum Receiver Input Current	V <sub>IN</sub> = 4V	V <sub>CC</sub> = V <sub>MAX</sub>		15.0	50.0	μA
			V <sub>CC</sub> = 0V		1.0	50.0	μA
I <sub>IL</sub>	Logical "0" Receiver Input Current	V <sub>IN</sub> = 0.4V, V <sub>CC</sub> = V <sub>MAX</sub>		1.0	50.0	μA	
V <sub>IH</sub>	Logical "1" Input Voltage	Disable	2.0			V	
V <sub>IL</sub>	Logical "0" Input Voltage	Disable			0.8	V	
I <sub>IH</sub>	Logical "1" Input Current	Disable Input	V <sub>IND</sub> = 2.4V			80.0	μA
			V <sub>IND</sub> = 5.5V			2.0	mA
I <sub>IL</sub>	Logical "0" Input Current	V <sub>IN</sub> = 4V, V <sub>IND</sub> = 0.4V, Disable Input			-3.2	mA	
V <sub>OH</sub>	Logical "1" Output Voltage	V <sub>IN</sub> = 0.5V, V <sub>IND</sub> = 0.8V, I <sub>OH</sub> = -400 μA	2.4			V	
V <sub>OL</sub>	Logical "0" Output Voltage	V <sub>IN</sub> = 4V, V <sub>IND</sub> = 0.8V, I <sub>OH</sub> = 16 mA		0.25	0.4	V	
I <sub>OS</sub>	Output Short Circuit Current	V <sub>IN</sub> = 0.5V, V <sub>IND</sub> = 0V, V <sub>OS</sub> = 0V, V <sub>CC</sub> = V <sub>MAX</sub> , (Note 4)	-18.0		-55.0	mA	
I <sub>CC</sub>	Power Supply Current	V <sub>IN</sub> = 4V, V <sub>IND</sub> = 0V, (Per Package)		45.0	60.0	mA	
V <sub>CL</sub>	Input Clamp Diode	V <sub>IN</sub> = -12 mA, V <sub>IND</sub> = -12 mA, T <sub>A</sub> = 25°C		-1.0	-1.5	V	

## Switching Characteristics $T_A = 25^\circ\text{C}$ , nominal power supplies unless otherwise noted

Symbol	Parameter	Conditions	Min	Typ	Max	Units	
$t_{pd}$	Propagation Delays	$V_{IND} = 0\text{V}$ , Receiver	Input to Logical "1" Output, (Note 5)		20	30	ns
			Input to Logical "0" Output, (Note 6)		18	30	ns
		Input = 0V, Disable, (Note 7)	Input to Logical "1" Output		9	15	ns
			Input to Logical "0" Output		4	10	ns

**Note 1:** "Absolute Maximum Ratings" are those values beyond which the safety of the device cannot be guaranteed. Except for "Operating Temperature Range" they are not meant to imply that the devices should be operated at these limits. The table of "Electrical Characteristics" provides conditions for actual device operation.

**Note 2:** Unless otherwise specified min/max limits apply across the  $-55^\circ\text{C}$  to  $+125^\circ\text{C}$  temperature range for the DS7837 and across the  $0^\circ\text{C}$  to  $+70^\circ\text{C}$  range for the DS8837. All typical values are for  $T_A = 25^\circ\text{C}$  and  $V_{CC} = 5\text{V}$ .

**Note 3:** All currents into device pins shown as positive, out of device pins as negative, all voltages referenced to ground unless otherwise noted. All values shown as max or min on absolute value basis.

**Note 4:** Only one output at a time should be shorted.

**Note 5:** Fan-out of 10 load,  $C_{LOAD} = 15\text{ pF}$  total. Measured from  $V_{IN} = 1.3\text{V}$  to  $V_{OUT} = 1.5\text{V}$ ,  $V_{IN} = 0\text{V}$  to  $3\text{V}$  pulse.

**Note 6:** Fan-out of 10 load,  $C_{LOAD} = 15\text{ pF}$  total. Measured from  $V_{IN} = 2.3\text{V}$  to  $V_{OUT} = 1.5\text{V}$ ,  $V_{IN} = 0\text{V}$  to  $3\text{V}$  pulse.

**Note 7:** Fan-out of 10 load,  $C_{LOAD} = 15\text{ pF}$  total. Measured from  $V_{IN} = 1.5\text{V}$  to  $V_{OUT} = 1.5\text{V}$ ,  $V_{IN} = 0\text{V}$  to  $3\text{V}$  pulse.

## Physical Dimensions inches (millimeters)

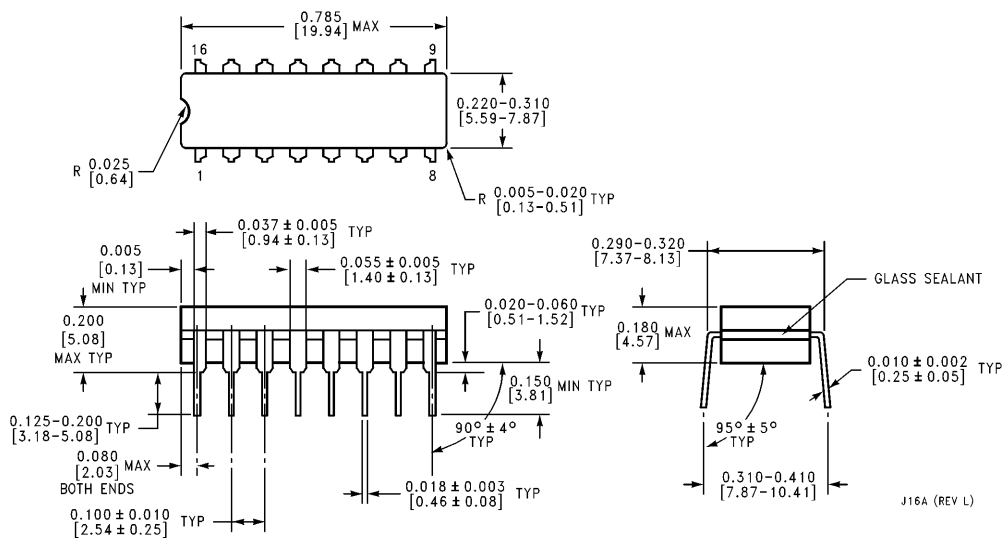

**Ceramic Dual-In-Line Package (J)**  
**Order Number DS7837J**  
**NS Package Number J16A**

**Physical Dimensions** inches (millimeters) (Continued)

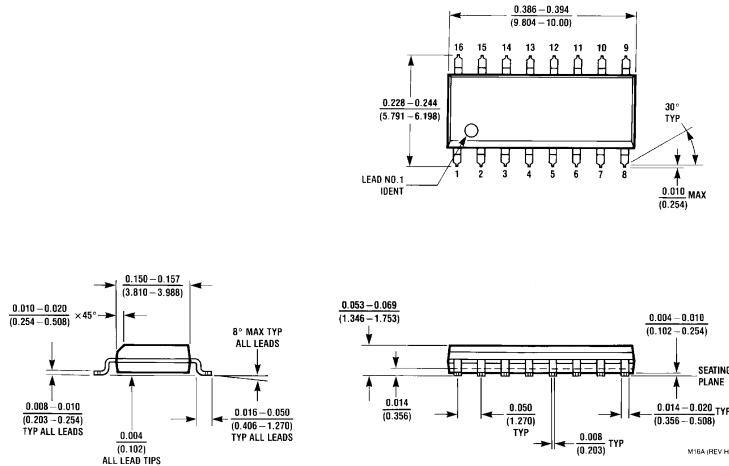

**SO Package (M)**  
**Order Number DS8837M**  
**NS Package Number M16A**

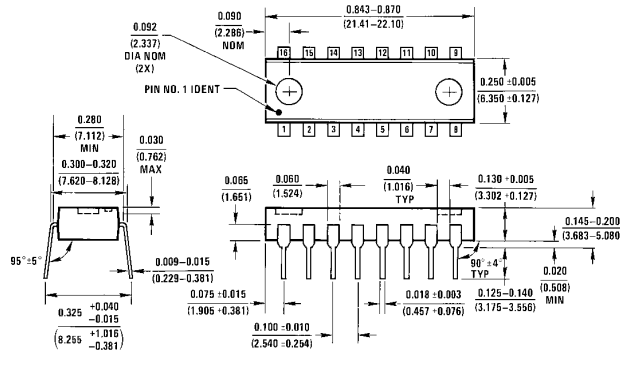

**Molded Dual-In-Line Package (N)**  
**Order Number DS8837N**  
**NS Package Number N16A**

**LIFE SUPPORT POLICY**

NATIONAL'S PRODUCTS ARE NOT AUTHORIZED FOR USE AS CRITICAL COMPONENTS IN LIFE SUPPORT DEVICES OR SYSTEMS WITHOUT THE EXPRESS WRITTEN APPROVAL OF THE PRESIDENT OF NATIONAL SEMICONDUCTOR CORPORATION. As used herein:

1. Life support devices or systems are devices or systems which, (a) are intended for surgical implant into the body, or (b) support or sustain life, and whose failure to perform, when properly used in accordance with instructions for use provided in the labeling, can be reasonably expected to result in a significant injury to the user.
2. A critical component is any component of a life support device or system whose failure to perform can be reasonably expected to cause the failure of the life support device or system, or to affect its safety or effectiveness.

**National Semiconductor Corporation**  
 1111 West Bardin Road  
 Arlington, TX 76017  
 Tel: 1(800) 272-9959  
 Fax: 1(800) 737-7018

**National Semiconductor Europe**  
 Fax: +49 (0) 180-530 85 86  
 Email: europe.support@nsc.com  
 Deutsch Tel: +49 (0) 180-530 85 85  
 English Tel: +49 (0) 180-532 78 32  
 Français Tel: +49 (0) 180-532 93 58  
 Italiano Tel: +49 (0) 180-534 16 80

**National Semiconductor Hong Kong Ltd.**  
 13th Floor, Straight Block,  
 Ocean Centre, 5 Canton Rd.  
 Tsimshatsui, Kowloon  
 Hong Kong  
 Tel: (852) 2737-1600  
 Fax: (852) 2736-9960

**National Semiconductor Japan Ltd.**  
 Tel: 81-043-299-2308  
 Fax: 81-043-299-2408

<http://www.national.com>