

Digital transistors (built-in resistors)

DTA114EE / DTA114EUA / DTA114EKA / DTA114ESA

●Features

- 1) Built-in bias resistors enable the configuration of an inverter circuit without connecting external input resistors (see equivalent circuit).
- 2) The bias resistors consist of thin-film resistors with complete isolation to allow positive biasing of the input. They also have the advantage of almost completely eliminating parasitic effects.
- 3) Only the on/off conditions need to be set for operation, making device design easy.

●Structure

PNP digital transistor
(Built-in resistor type)

●Equivalent circuit

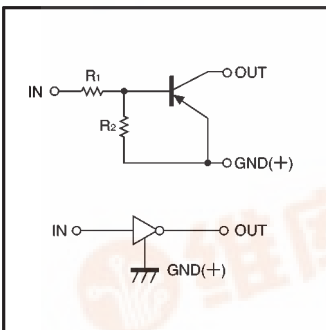

●External dimensions (Units: mm)

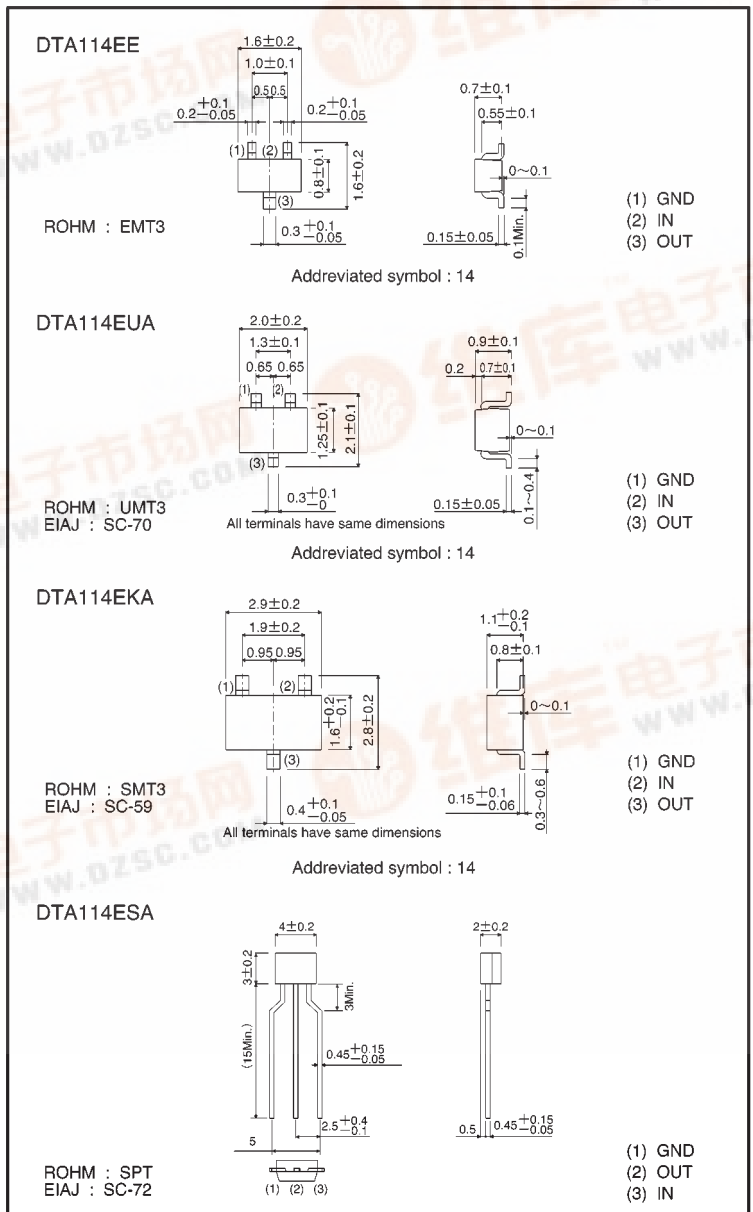

Transistors

DTA114EE/DTA114EUA/DTA114EKA/DTA114ESA

● Absolute maximum ratings (Ta = 25°C)

Parameter	Symbol	Limits(DTA114E□)				Unit
		E	UA	KA	SA	
Supply voltage	V _{CC}	-50				V
Input voltage	V _{IN}	-40~+10				V
Output current	I _o	-50				mA
	I _{c(Max.)}	-100				
Power dissipation	P _d	150	200	300	mW	
Junction temperature	T _j	150				°C
Storage temperature	T _{stg}	-55~+150				°C

● Electrical characteristics (Ta = 25°C)

Parameter	Symbol	Min.	Typ.	Max.	Unit	Conditions
Input voltage	V _{I(off)}	—	—	-0.5	V	V _{CC} =-5V, I _o =-100 μA
	V _{I(on)}	-3	—	—		V _o =-0.3V, I _o =-10mA
Output voltage	V _{O(on)}	—	—	-0.3	V	I _o /I _i =-10mA/-0.5mA
Input current	I _i	—	—	-0.88	mA	V _I =-5V
Output current	I _{O(off)}	—	—	-0.5	μA	V _{CC} =-50V, V _I =0V
DC current gain	G _i	30	—	—	—	V _o =-5V, I _o =-5mA
Input resistance	R ₁	7	10	13	kΩ	—
Resistance ratio	R ₂ /R ₁	0.8	1	1.2	—	—
Transition frequency	f _r	—	250	—	MHz	V _{CE} =-10V, I _E =5mA, f=100MHz *

* Transition frequency of the device

● Packaging specifications

Part No.	Package	EMT3	UMT3	SMT3	SST3	SPT
	Package type	Taping	Taping	Taping	Taping	Taping
	Code	TL	T106	T146	T116	TP
	Basic ordering unit (pieces)	3000	3000	3000	3000	5000
DTA114EE	○	—	—	—	—	—
DTA114EUA	—	○	—	—	—	—
DTA114EKA	—	—	○	—	—	—
DTA114ECA	—	—	—	○	—	—
DTA114ESA	—	—	—	—	—	○

● Electrical characteristic curves

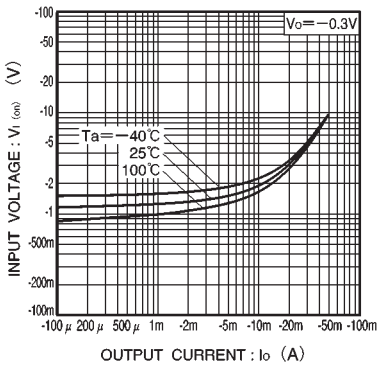

Fig.1 Input voltage vs. output current (ON characteristics)

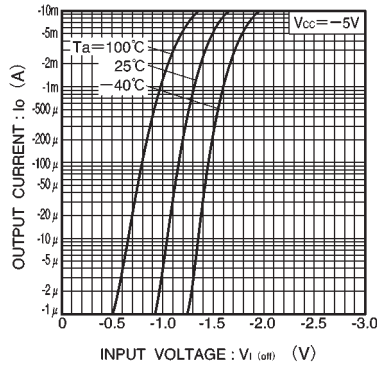

Fig.2 Output current vs. input voltage (OFF characteristics)

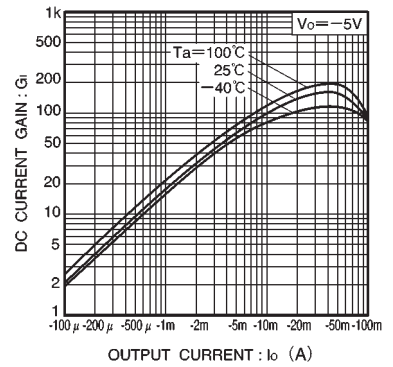

Fig.3 DC current gain vs. output current

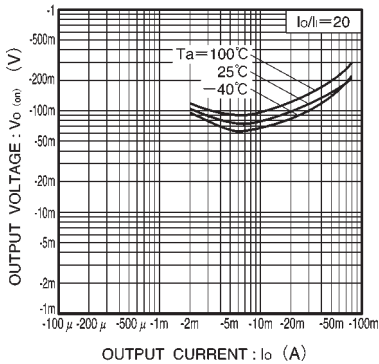

Fig.4 Output voltage vs. output current