

DTDG14GP

Transistors

Digital transistor (built in resistor and zener diode) Driver (60V, 1A)

DTDG14GP

●Features

- 1) High  $h_{FE}$ .  
(typ.  $h_{FE}=750$   $V_{CE}/I_C=2V/0.5A$ )
- 2) Low saturation voltage,  
 $V_{CE(sat)}=0.4V$   
( $I_C/I_B=500mA/5mA$ )
- 3) Built-in zener diode to protect the transistor against reverse voltages when connected to allow load.

●Structure

NPN digital transistor  
(with single built resistor and zener diode)

●External dimensions (Units : mm)

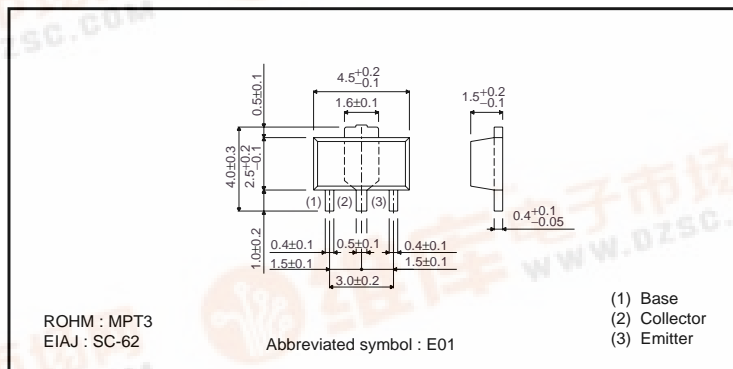

●Absolute maximum ratings ( $T_a = 25^{\circ}C$ )

Parameter	Symbol	Limits	Unit
Collector-base voltage	$V_{CBO}$	60±10	V
Collector-emitter voltage	$V_{CEO}$	60±10	V
Emitter-base voltage	$V_{EBO}$	5	V
Collector current	$I_C$	1	A
	$I_{CP}$	2	A(Pulse) *1
Collector power dissipation	$P_C$	0.5	W *2
		2	
Junction temperature	$T_j$	150	$^{\circ}C$
Storage temperature	$T_{stg}$	-55~+150	$^{\circ}C$

\*1  $P_w \leq 10ms$ , Duty cycle  $\leq 1/2$

\*2 When mounted on a 40×40×0.7 mm ceramic board.

●Equivalent circuit

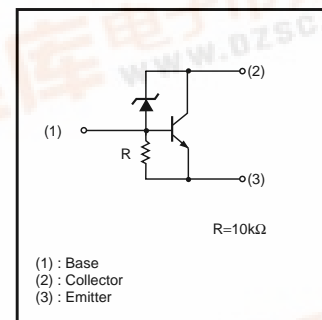

Transistors

●Electrical characteristics (Ta = 25°C)

Parameter	Symbol	Min.	Typ.	Max.	Unit	Conditions
Collector-base breakdown voltage	BV <sub>CB0</sub>	50	–	70	V	I <sub>C</sub> =50μA
Collector-emitter breakdown voltage	BV <sub>CEO</sub>	50	–	70	V	I <sub>C</sub> =1mA
Emitter-base breakdown voltage	BV <sub>EBO</sub>	5	–	–	V	I <sub>E</sub> =720μA
Collector cutoff current	I <sub>CBO</sub>	–	–	0.5	μA	V <sub>CB</sub> =40V
Emitter cutoff current	I <sub>EBO</sub>	300	–	580	μA	V <sub>EB</sub> =4V
Collector-emitter saturation voltage	V <sub>CE(sat)</sub>	–	–	0.4	V	I <sub>C</sub> /I <sub>B</sub> =500mA/5mA
DC current transfer ratio	h <sub>FE</sub>	300	–	–	–	V <sub>CE</sub> =2V, I <sub>C</sub> =500mA
Emitter-base resistance	R	7	10	13	kΩ	–
Transition frequency	f <sub>r</sub>	–	80	–	MHz	V <sub>CE</sub> =5V, I <sub>E</sub> =–0.1A, f=30MHz *

\*Transition frequency of the device

●Packaging specifications

Part No.	Package	MPT3
	Packaging type	Taping
	Code	T100
	Basic ordering unit (pieces)	1000
DTDG14GP		○

●Electrical characteristic curves

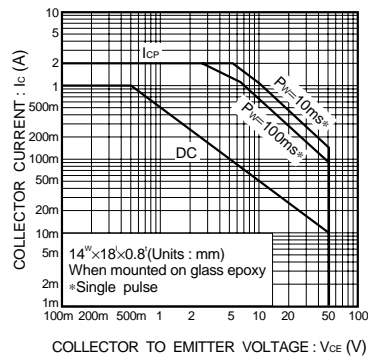

Fig.1 Safe operating area

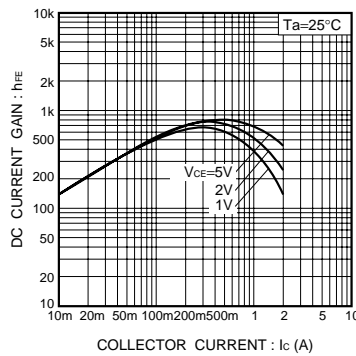

Fig.2 DC current gain vs. collector current

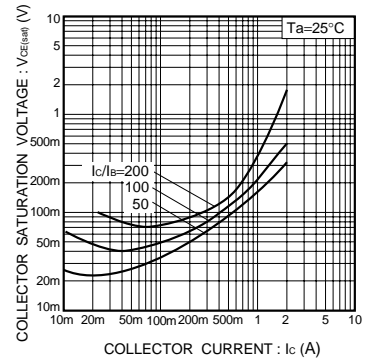

Fig.3 Collector-emitter saturation voltage vs. collector current