

SANYO	No.2303A	DTM10-N Silicon Planar Type 10A Bidirectional Thyristor
--------------	----------	---

Features

- Insulation type
- Peak OFF-state voltage : 200 to 600V
- RMS ON-state current : 10A
- TO-220 package

Absolute Maximum Ratings at Ta = 25°C

		DTM10C-N	DTM10E-N	DTM10G-N	unit
Repetitive Peak OFF-State Voltage	V_{DRM}	200	400	600	V
RMS ON-State Current	I_T (RMS)	→		10	A
Surge ON-State Current	I_{TSM}	→		100	A
Amperes Squared-Seconds	$\int i^2 T \cdot dt$	→		32	A ² s
Peak Gate Power Dissipation	P_{GM}	→		5	W
Average Gate Power Dissipation	$P_{G(AV)}$	→		0.5	W
Peak Gate Current	I_{GM}	→		±2	A
Peak Gate Voltage	V_{GM}	→		±10	V
Junction Temperature	T_j	→		125	°C
Storage Temperature	T_{stg}	→		-40 to +125	°C
Weight		→		1.8	g

Electrical Characteristics at Ta = 25°C

		$T_j = 125^\circ\text{C}, V_D = V_{DRM}$	min	typ	max	unit
Repetitive Peak OFF-State Current	I_{DRM}				2	mA
Peak ON-State Voltage	V_{TM}	$I_{TM} = 17\text{A}$			1.5	V
Critical Rate of Rise of OFF-State Voltage	$(dv/dt)_c$	$T_j = 125^\circ\text{C}, V_D = 200\text{V (C)}, 400\text{V (E to G)}$	10			V/ μs
Holding Current	I_H	$R_L = 100\Omega$			50	mA

Continued on next page.

※ : The gate trigger mode is shown below.

Trigger mode	T2	T1	G
I	+	-	+
II	+	-	-
III	-	+	+
IV	-	+	-

Package Dimensions 1144 (unit: mm)

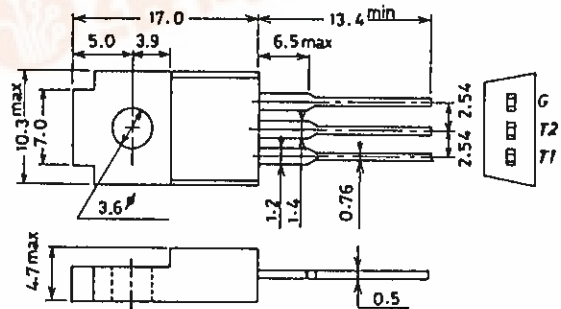

DTM10-N

Continued from preceding page.

			min	typ	max	unit
Gate Trigger Current (I)	I_{GT}	$V_D = 12V, R_L = 20\Omega$			30	mA
"	(II) I_{GT}	$V_D = 12V, R_L = 20\Omega$			30	mA
"	(III) I_{GT}	$V_D = 12V, R_L = 20\Omega$			50	mA
"	(IV) I_{GT}	$V_D = 12V, R_L = 20\Omega$			30	mA
Gate Trigger Voltage (I)	V_{GT}	$V_D = 12V, R_L = 20\Omega$			2	V
"	(II) V_{GT}	$V_D = 12V, R_L = 20\Omega$			2	V
"	(III) V_{GT}	$V_D = 12V, R_L = 20\Omega$			2	V
"	(IV) V_{GT}	$V_D = 12V, R_L = 20\Omega$			2	V
Gate Nontrigger Voltage	V_{GD}	$T_c = 125^\circ C, V_D = V_{DRM}$	0.2			V
Thermal Resistance	$R_{th(j-c)}$	Between junction and case, AC			3.0	$^\circ C/W$

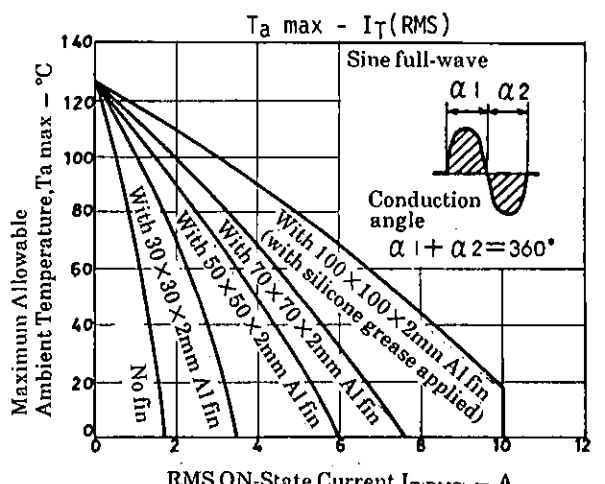
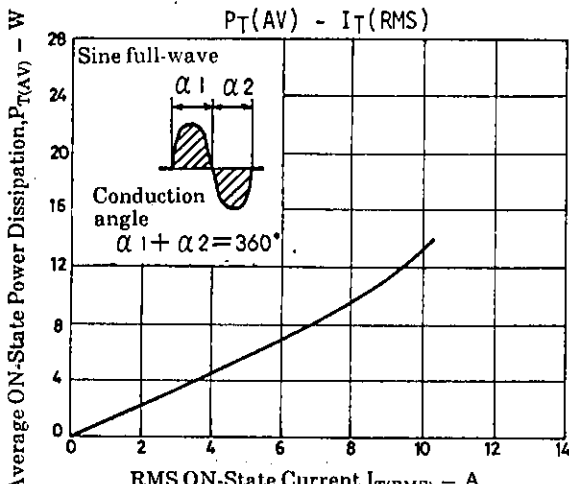
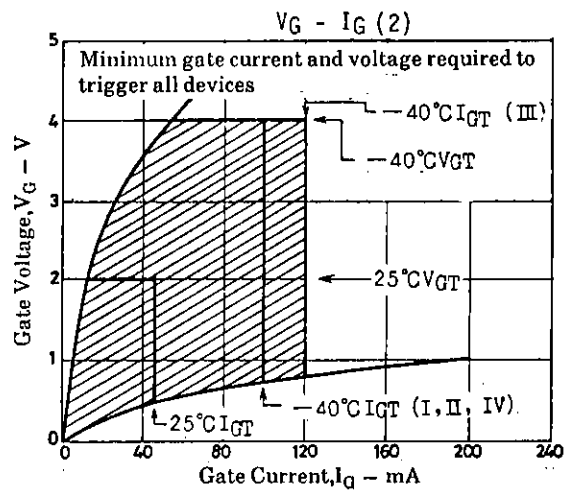
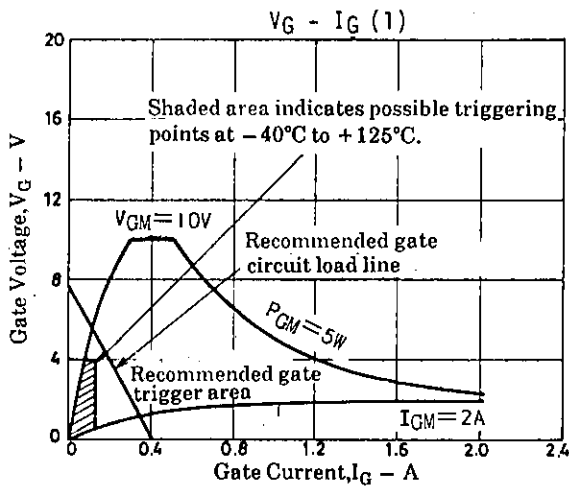
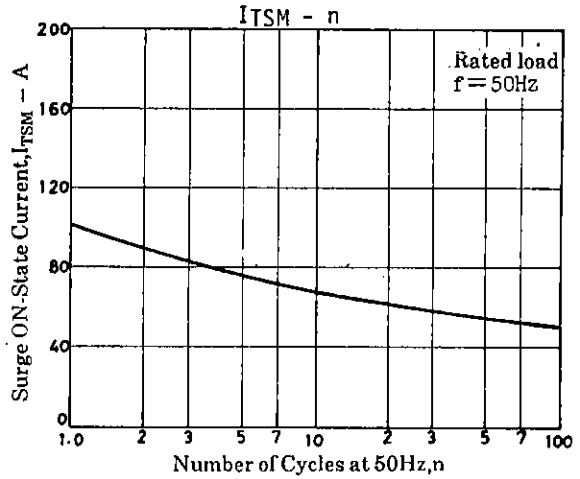
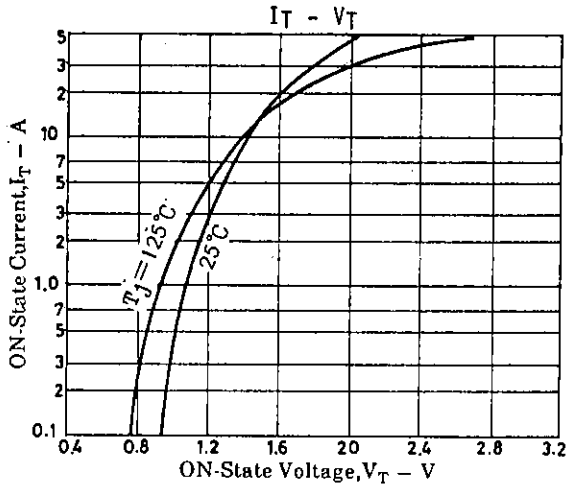

DTM10-N

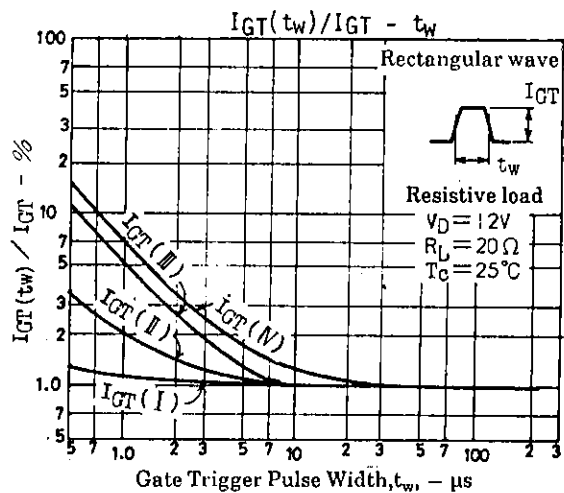
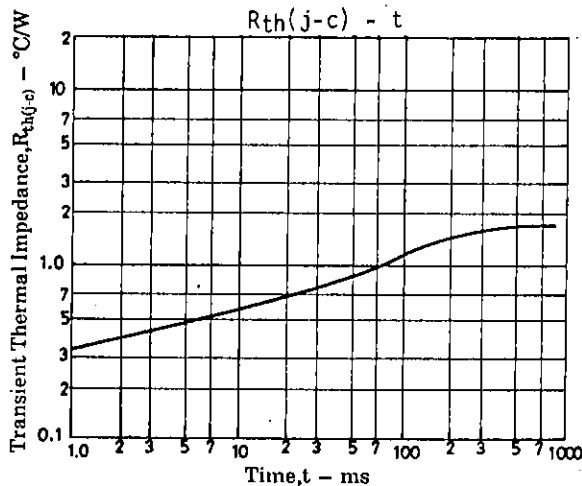
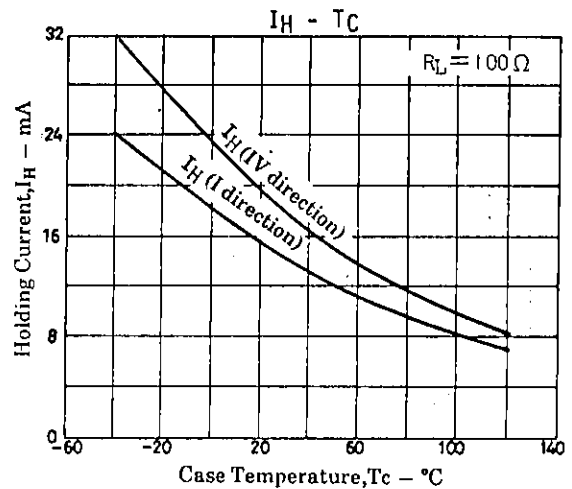
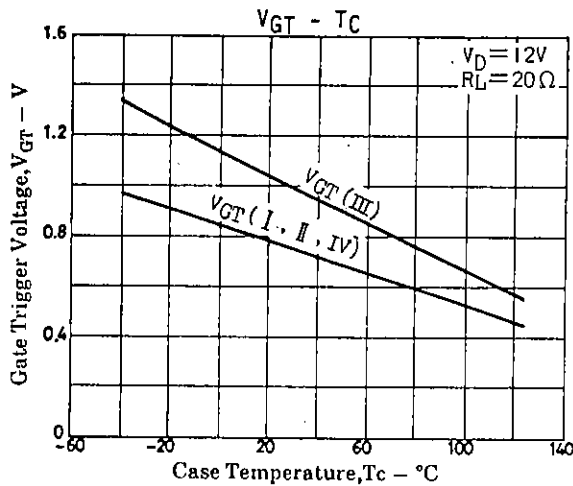
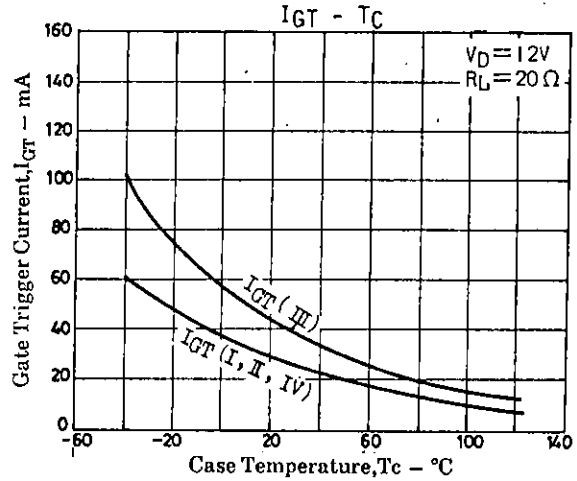
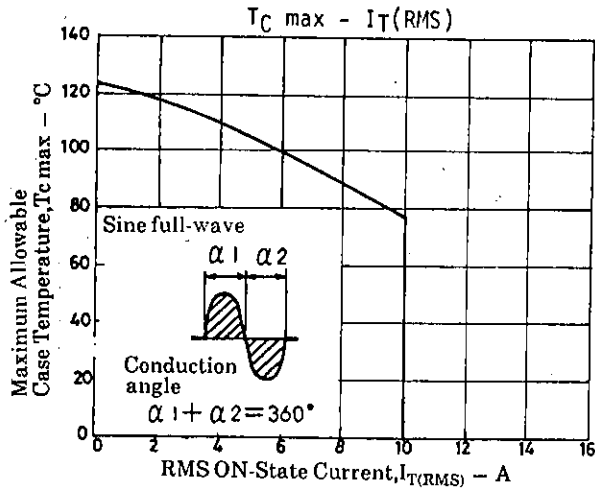

■ No products described or contained herein are intended for use in surgical implants, life-support systems, aerospace equipment, nuclear power control systems, vehicles, disaster/crime-prevention equipment and the like, the failure of which may directly or indirectly cause injury, death or property loss.

■ Anyone purchasing any products described or contained herein for an above-mentioned use shall:

- ① Accept full responsibility and indemnify and defend SANYO ELECTRIC CO., LTD., its affiliates, subsidiaries and distributors and all their officers and employees, jointly and severally, against any and all claims and litigation and all damages, cost and expenses associated with such use.
- ② Not impose any responsibility for any fault or negligence which may be cited in any such claim or litigation on SANYO ELECTRIC CO., LTD., its affiliates, subsidiaries and distributors or any of their officers and employees jointly or severally.

■ Information (including circuit diagrams and circuit parameters) herein is for example only; it is not guaranteed for volume production. SANYO believes information herein is accurate and reliable, but no guarantees are made or implied regarding its use or any infringements of intellectual property rights or other rights of third parties.