



DVMA28 Series

HIGH RELIABILITY HYBRID EMI FILTERS

DESCRIPTION

The DVMA series of hybrid EMI filters is operable over the full military (-55 °C to +125 °C) temperature range with no power derating. The DVMA EMI filter is designed to filter conducted emissions of two DVSA or one DVHF series DC-DC converters.

These filters are designed and manufactured in a facility qualified to ISO9001 and certified to MIL-PRF-38534 and MIL-STD-883.

FEATURES

- High Reliability
- Wide Input Voltage Range: 0 to 50 Volts per MIL-STD-704
- Up to 1.0 Amp Maximum Current
- 40 dB Minimum Attenuation at 500 kHz
- Industry Standard Pinout
- High Input Transient Voltage: 80 Volts for 1 sec per MIL-STD-704A
- Precision Projection Welded Hermetic Package
- Custom Versions Available
- Additional Environmental Screening Available
- Meets MIL-STD-461C and MIL-STD-461D EMC Requirements
- Protects Against Conducted Susceptibility Specified in MIL-STD-461C, CS01 and CS02
- MIL-PRF-38534 Element Evaluated Components



Figure 1 – DVMA28 EMI Filter
(Not To Scale)

SPECIFICATIONS ($T_{CASE} = -55^{\circ}\text{C}$ to $+125^{\circ}\text{C}$, $V_{IN} = +28\text{V} \pm 5\%$, Full Load, Unless Otherwise Specified)

ABSOLUTE MAXIMUM RATINGS			
Input Voltage (Continuous)	50 V _{DC}	Storage Temperature	-65°C to +150°C
Input Voltage (Transient, 1 second)	80 Volts	Lead Solder Temperature (10 seconds)	300°C
Output Current	1.0 Amp	Weight (Maximum)	15 Grams
Power Dissipation (Full Load, $T_{CASE} = +125^{\circ}\text{C}$)	0.16 Watts		

Parameter	Conditions	DVMA28			Units
		Min	Typ	Max	
STATIC					
INPUT Voltage ²	Continuous	0	28	50	V
	Transient, 1 sec	-	-	80	V
Current ^{1,3}	Continuous	0	-	1.0	A
OUTPUT Voltage	Continuous	$V_{OUT} = V_{IN} - (I_{IN} \times R_{DC})$			V
Current ³	Continuous	0	-	1.0	A
DC RESISTANCE	Continuous	-	-	160	mΩ
POWER DISSIPATION ²	Continuous	-	-	0.16	W
NOISE REJECTION	f = 500 kHz	40	-	-	dB
CAPACITANCE	Pin to Case	13	-	27	nF
ISOLATION	Any Pin to Case, 500 V _{DC}	100	-	-	MΩ
MTBF (MIL-HDBK-217F)	AIF @ $T_c = 55^{\circ}\text{C}$	-	3.15	-	MHrs

- Notes:
1. Derate linearly to 0 at 135°C.
 2. Verified by qualification testing.
 3. Rated current applies at any voltage.

BLOCK DIAGRAM

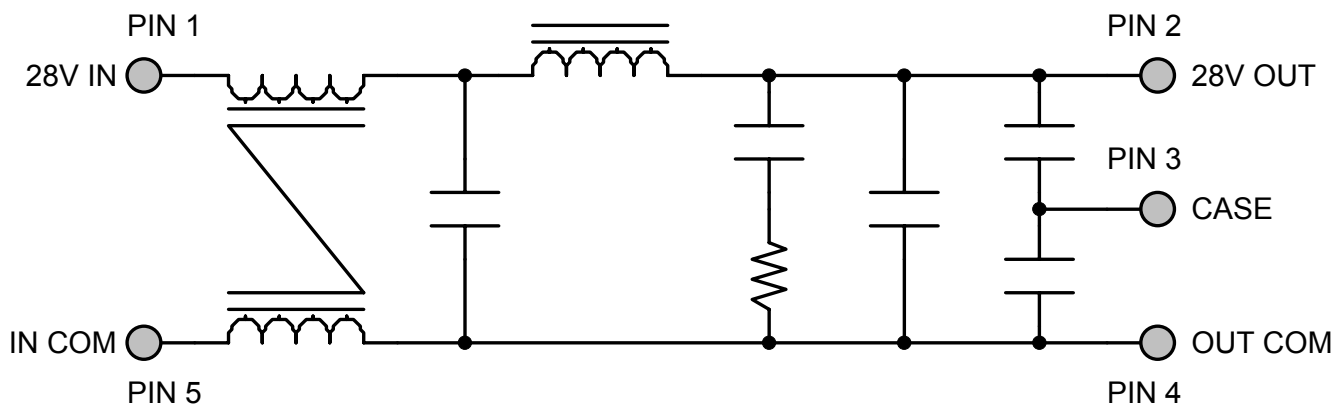

Figure 2

CONNECTION DIAGRAMS

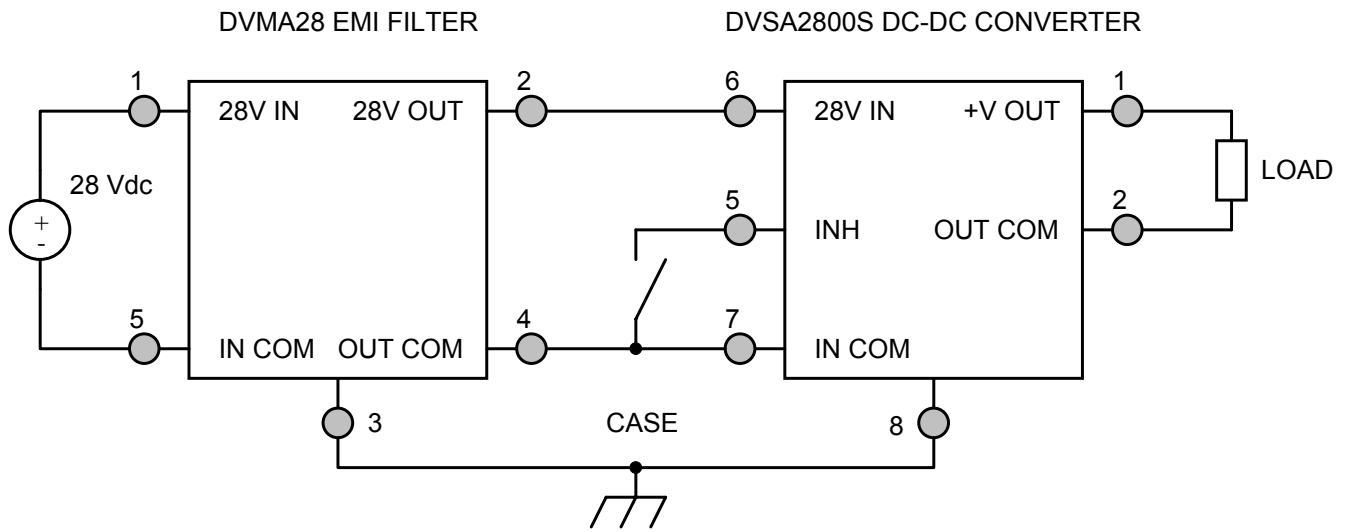

Figure 3 – DVMA28 EMI Filter Hookup with Single Converter

CONNECTION DIAGRAMS

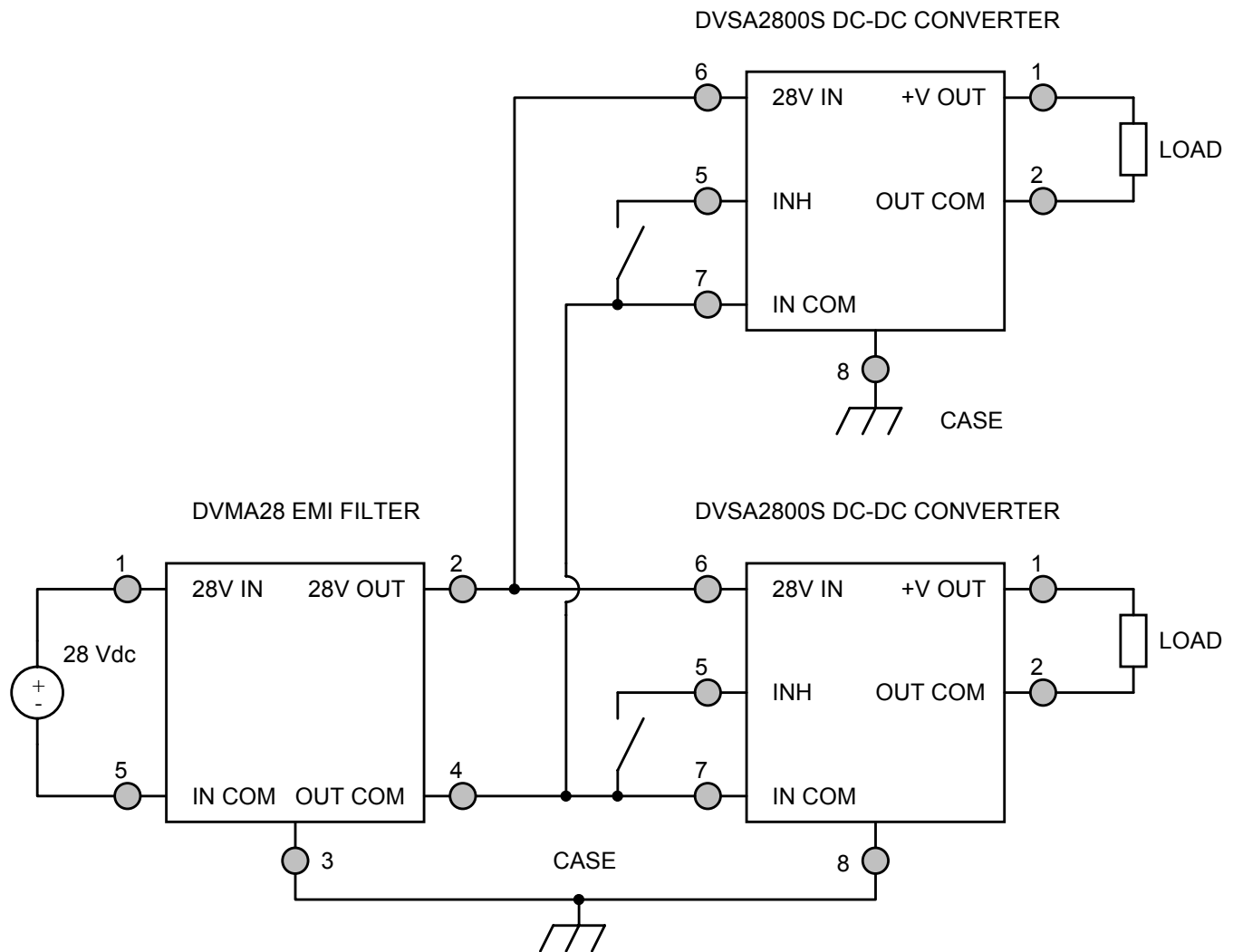

Figure 4 – DVMA28 EMI Filter Hookup with Two Converters

EMI MEASUREMENT METHODS CONNECTION DIAGRAMS

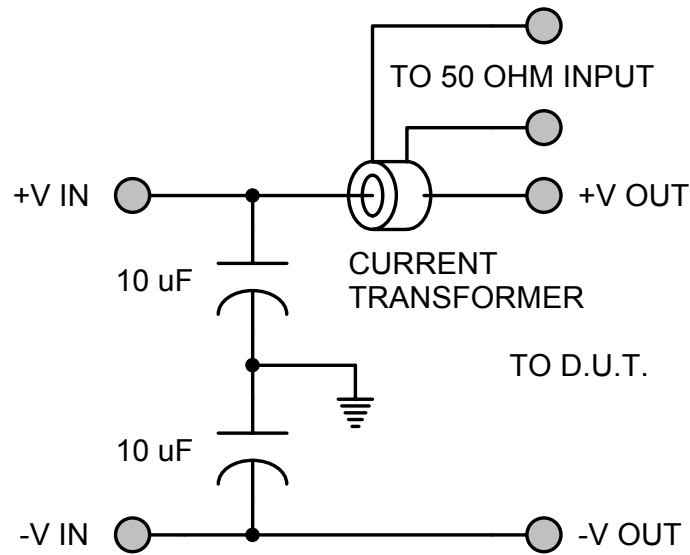

Figure 5 – MIL-STD-461C Measurement Method (Feedthrough Capacitor)

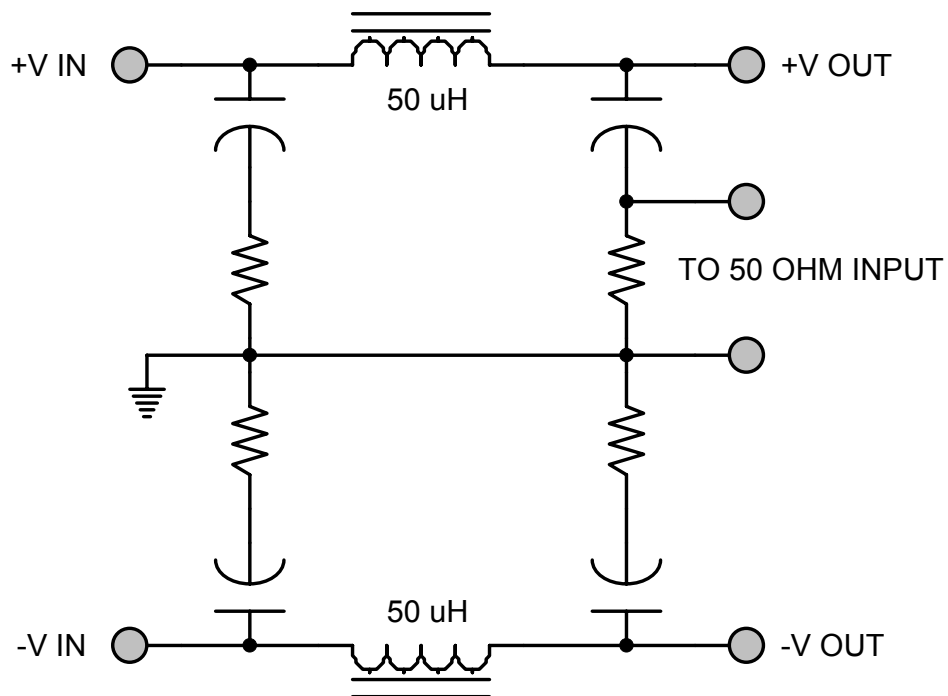

Figure 6 – MIL-STD-461D Measurement Method (LISN)

EMI PERFORMANCE CURVES

($T_{CASE} = 25^{\circ}C$, $V_{IN} = +28V \pm 5\%$, Full Load, Unless Otherwise Specified)

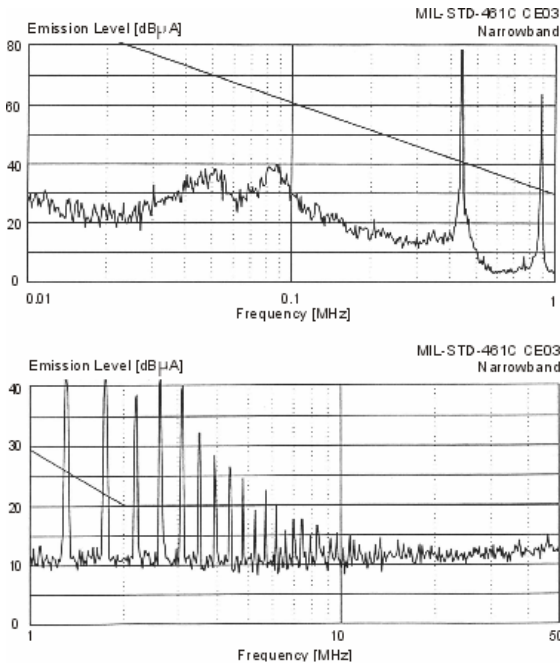

Figure 7 – MIL-STD-461C DVSA2800D Without EMI Filter

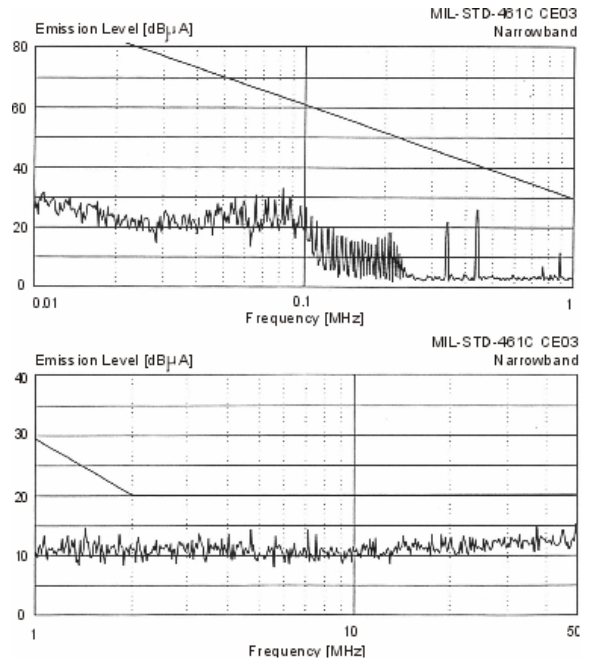

Figure 8 – MIL-STD-461C DVSA2800D With DVMA28 EMI Filter

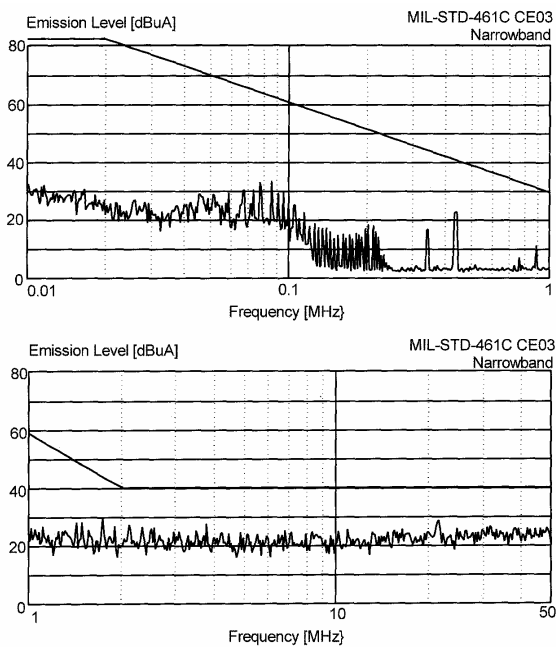

Figure 9 – MIL-STD-461C Two DVSA2800S's With DVMA28 EMI Filter

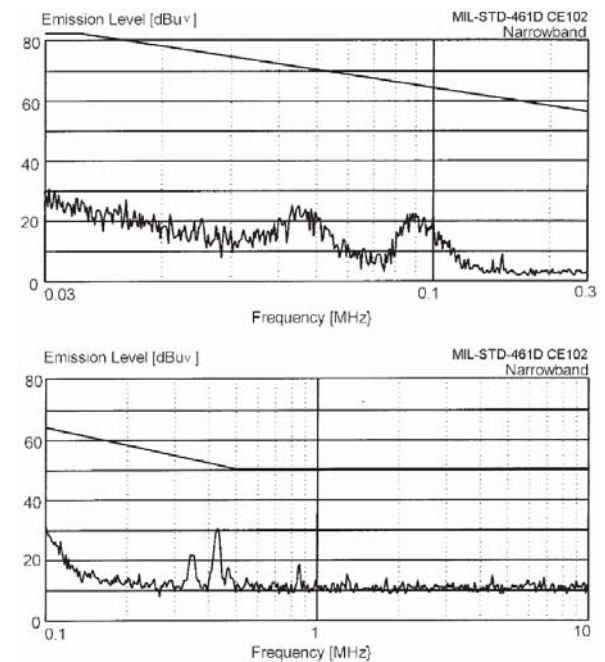
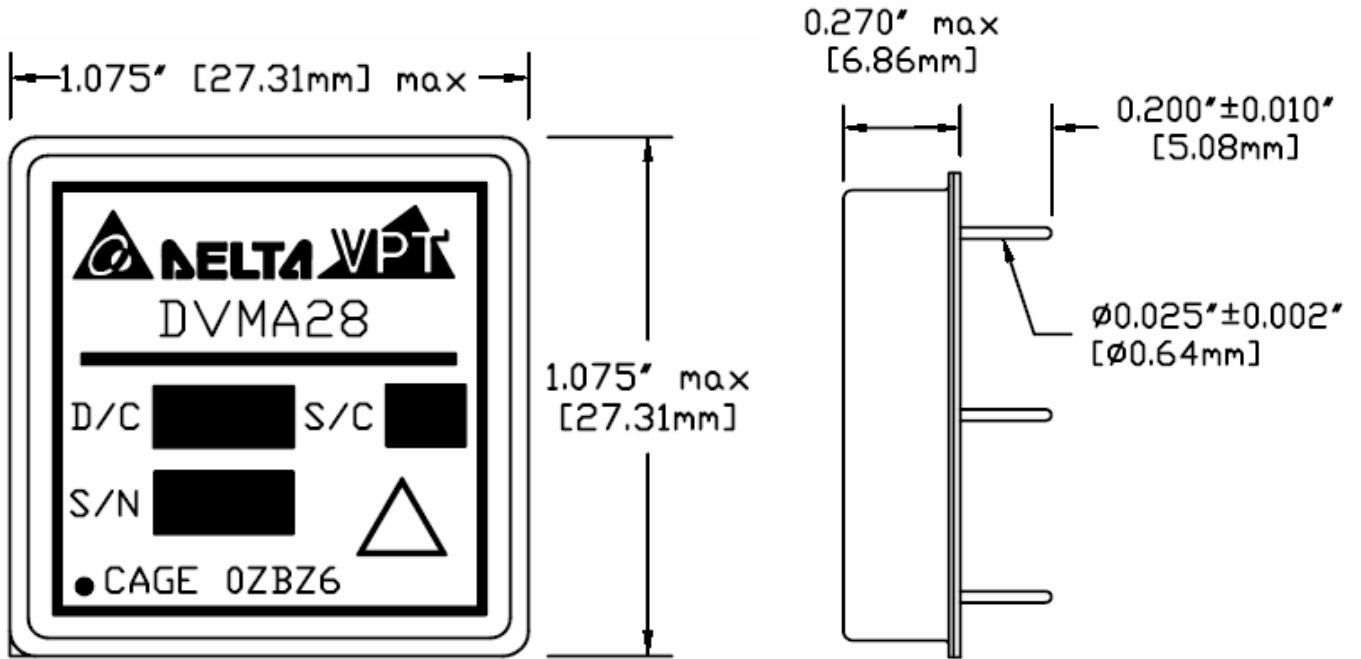

Figure 10 – MIL-STD-461D DVSA2800S With DVMA28 EMI Filter

PACKAGE SPECIFICATIONS



TOP VIEW

SIDE VIEW

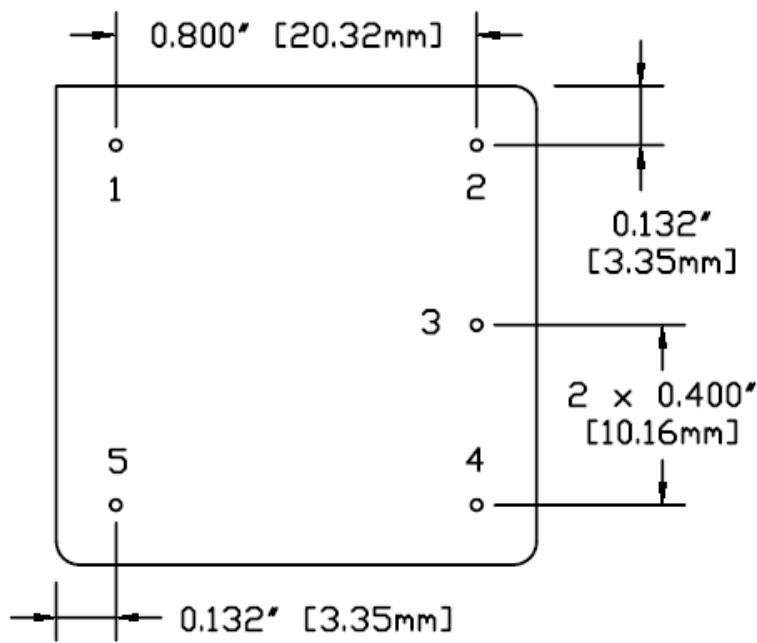

BOTTOM VIEW

PIN	FUNCTION
1	28V IN
2	28V OUT
3	CASE
4	OUT COM
5	IN COM

Figure 11 – Package and Pinout
(Dimensional Limits are $\pm 0.005"$ Unless Otherwise Stated)

PACKAGE PIN DESCRIPTION

Pin	Function	Description
1	28V IN	Positive Input Voltage Connection
2	28V OUT	Positive Output Voltage Connection
3	CASE	Case Connection
4	OUT COM	Output Common Connection
5	IN COM	Input Common Connection

ENVIRONMENTAL SCREENING (Per MIL-STD-883 as referenced to MIL-PRF-38534, Class H)

Screening	MIL-STD-883	Standard (No Suffix)	Extended /ES	HB /HB
Pre-Cap Inspection	Method 2017, 2032 Internal Procedure	•	•	•
Temperature Cycling	Method 1010, Condition C Method 1010, -55°C to 125°C		•	•
Constant Acceleration	Method 2001, 3000g Method 2001, 500g		•	•
Burn-In	Method 1015, 160 hours at +125°C 96 hours at +125°C 24 hours at +125°C	•	•	•
Hermeticity	Method 1014, Fine Leak, Condition A Method 1014, Gross Leak, Condition C Dip (1×10^{-3})	•	• •	• •
Final Electrical	MIL-PRF-38534, Group A ¹ 100% at 25°C	•	•	•
Final Inspection	Method 2009	•	•	•

Note: 1. 100% R&R testing at -55°C, +25°C, and +125°C with all test data included in product shipment.

ORDERING INFORMATION

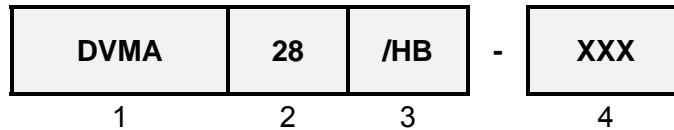

(1)

(2)

(3)

(4)

Product Series	Nominal Input Voltage		Screening Code		Additional Screening Code
DVMA	28	28 Volts	None /ES /HB	Standard Extended HB	Contact Sales

Please contact your sales representative or the VPT Inc. Sales Department for more information concerning additional environmental screening and testing, different input voltage, output voltage, power requirement, source inspection, and/or special element evaluation for space or other higher quality applications.

CONTACT INFORMATION

To request a quotation or place an order please contact your sales representative or the VPT Inc. Sales Department at:

Phone: (425) 487-4850
Fax: (425) 487-4802
E-mail: sales@vpt-inc.com