



DVMN28

HIGH RELIABILITY EMI FILTER AND INPUT ATTENUATOR

DESCRIPTION

The DVMN28 is a combined EMI filter and voltage spike protection module that is operable over a wide temperature range (-55 °C to +100 °C) with no power derating. The DVMN28 EMI filter works with VPT/Delta's DV200 series DC-DC converters to meet the surge requirements of MIL-STD-704A, B, C, and D with up to 250 watts of output power. These devices also reduce the reflected noise of the DC-DC converters to meet MIL-STD-461C CE03 and MIL-STD-461D CE102 limits. The DVMN28 filter also protects the DC-DC converters against the voltage spikes specified in MIL-STD-461C CS06 and conducted susceptibility in MIL-STD-461C CS01 and CS02.

These filters are designed and manufactured in a facility qualified to ISO9001 and certified to MIL-PRF-38534 and MIL-STD-883.

FEATURES

- High Reliability
- 250 Watt Output Power
- 50 dB Minimum Attenuation at 500 kHz
- Soft Start
- Under Voltage Lockout
- Clamps Output Voltage to 58 Volts Maximum
- Standard Quarter-Brick Size
- Custom Versions Available
- Additional Environmental Screening Available
- Meets MIL-STD-704A, B, C, and D Surge Limits
- Designed to meet MIL-STD-461C CE03 and MIL-STD-461D CE102 and DEF STAN 59-41 and 61-5 EMC Requirements
- Protects Against Conducted Susceptibility Specified in MIL-STD-461C, CS01 and CS02 and Against Voltage Spikes Specified in MIL-STD-461C CS06

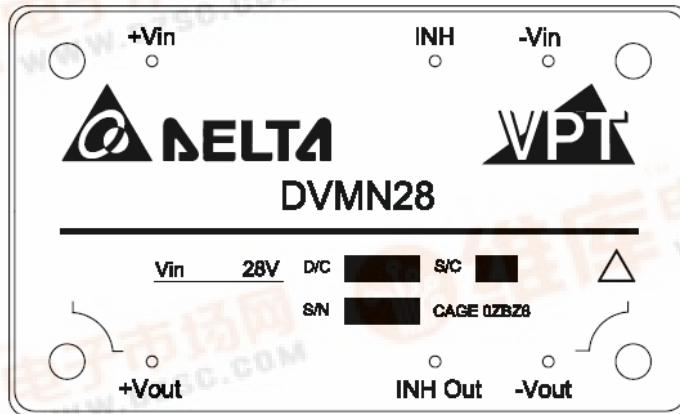

Figure 1 – DVMN28 EMI Filter
(Not To Scale)



SPECIFICATIONS ($T_{CASE} = -55^{\circ}\text{C}$ to $+100^{\circ}\text{C}$, $V_{IN} = +28\text{V} \pm 5\%$, Full Load, Unless Otherwise Specified)

ABSOLUTE MAXIMUM RATINGS			
Input Voltage (Continuous)	50 V_{DC}	Power Dissipation (Continuous)	12 Watts
Input Voltage (Transient, up to 10 μs)	600 Volts	Storage Temperature	-65 $^{\circ}\text{C}$ to +135 $^{\circ}\text{C}$
Output Current ¹	14 Amps	Lead Solder Temperature (10 seconds)	300 $^{\circ}\text{C}$
Weight (Maximum)	75 Grams		

Parameter	Conditions	DVMN28			Units	
		Min	Typ	Max		
STATIC						
INPUT Voltage ²	Continuous	With load	16	28	50	V
	Transient	5 ms, $R_S = 0.5 \Omega$	-40	-	70	V
	Transient ³	50 ms, $R_S = 0.5 \Omega$	-	-	110	V
	Transient	10 μs , $R_S = 50 \Omega$	-	-	600	V
Current	No Load		-	-	12	mA
	Inhibited		-	-	2.0	mA
OUTPUT Voltage	Continuous	$V_{OUT} = V_{IN} - (I_{IN} \times R_{DC})$			V	
Power ^{1,4}	Continuous			250	W	
Current ^{1,4}	Continuous			14	A	
INHIBIT PIN VOLTAGE ²	Open Circuit		-	14	16	V
	Inhibited		0	-	0.8	V
INHIBIT PIN CURRENT ²	Inhibit Pin Voltage = 0 to 0.8 V		-	-	-300	μA
UNDERVOLTAGE LOCKOUT			7	-	14	V
OUTPUT CLAMP VOLTAGE			51	-	55	V
DC RESISTANCE	Continuous				60	$\text{m}\Omega$
POWER DISSIPATION	Continuous		-	-	12	W
NOISE REJECTION	f = 500 kHz		50	60	-	dB
CAPACITANCE ²	Pin to Case		-	85	-	nF
ISOLATION	Any Pin to Case, 500 V_{DC}		100	-	-	$\text{M}\Omega$
MTBF (MIL-HDBK-217F)	GB @ $T_C = 55^{\circ}\text{C}$		-	2052	-	kHrs

- Notes:
1. Derate linearly to 0 at 110 $^{\circ}\text{C}$.
 2. Verified by qualification testing.
 3. Output inhibit used with load converters as in Figure 3.
 4. Maximum rating applies at any voltage.

BLOCK DIAGRAM

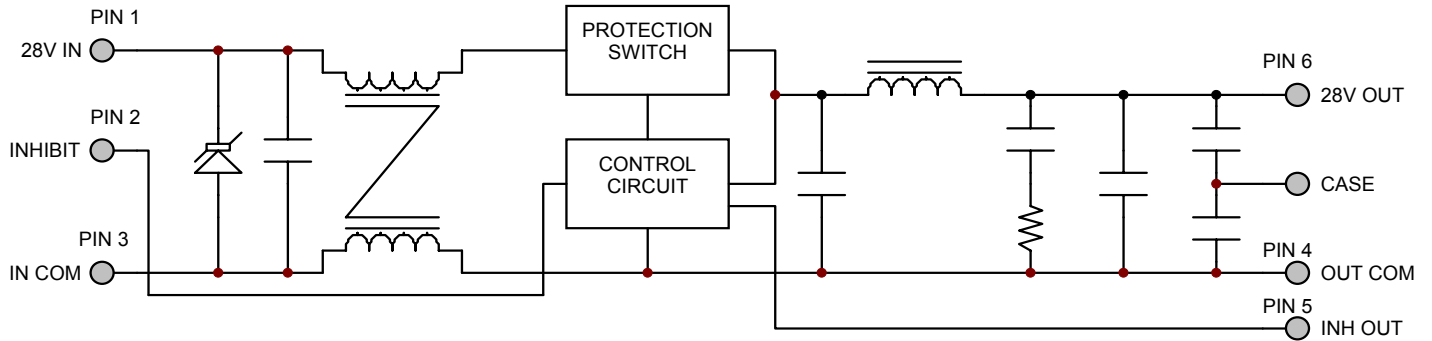

Figure 2

CONNECTION DIAGRAM

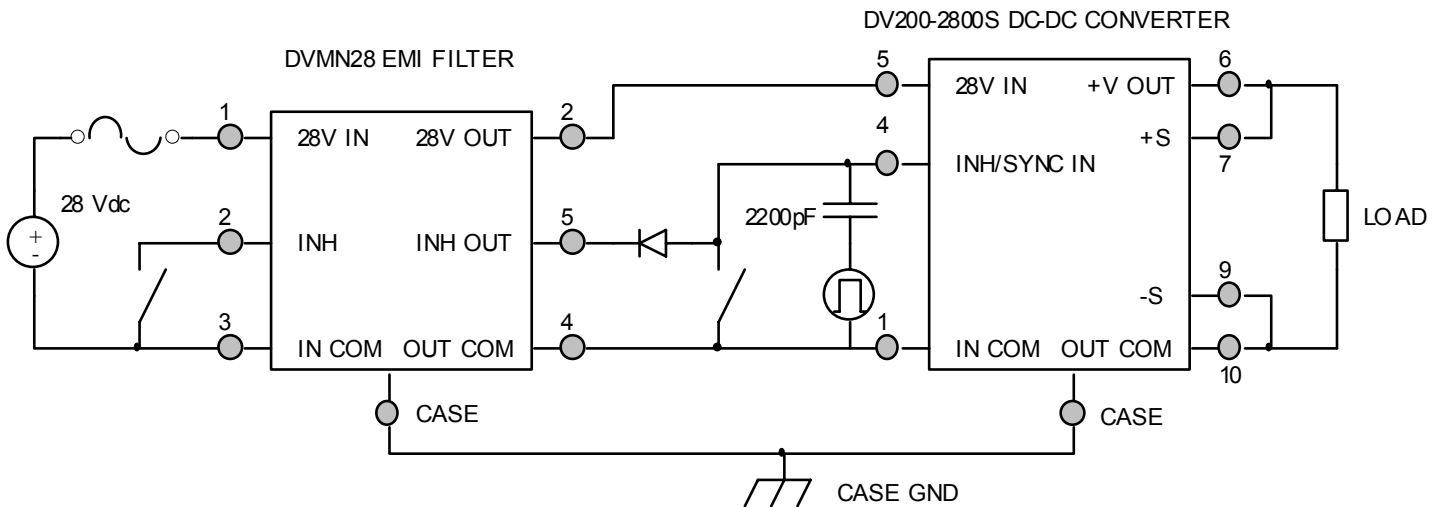

Figure 3 – DVMN28 EMI Filter Hookup with Single Converter
 (Diode on pin 5 of DVMN28 is needed when synchronization function of the converter is used.)

INHIBIT DRIVE CONNECTION DIAGRAM

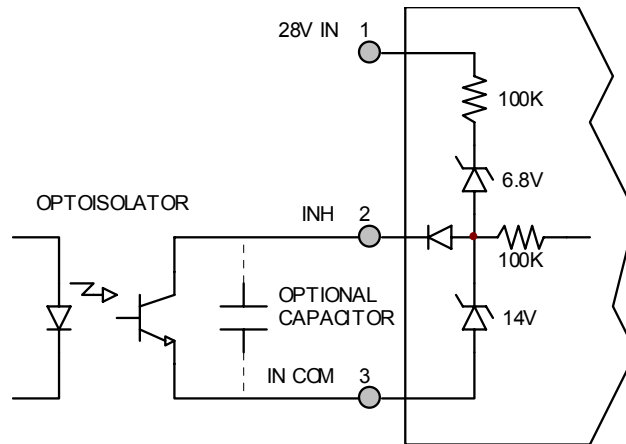

Figure 4 – Isolated Inhibit Drive
(Shown with optional capacitor for turn-on delay)

EMI MEASUREMENT METHODS CONNECTION DIAGRAMS

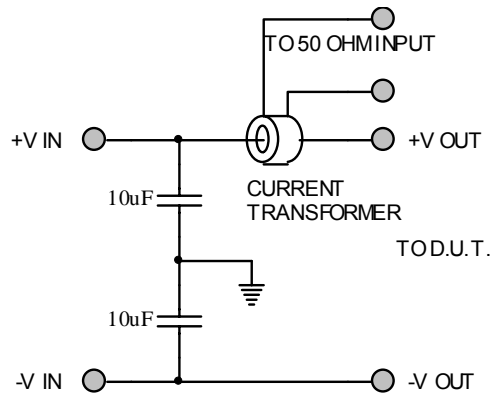

Figure 5 – MIL-STD-461C Measurement Method (Feedthrough Capacitor)

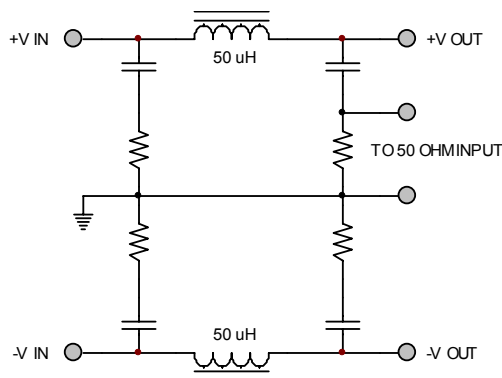

Figure 6 – MIL-STD-461D Measurement Method (LISN)

EMI PERFORMANCE CURVES

($T_{CASE} = 25^{\circ}C$, $V_{IN} = +28V \pm 5\%$, Full Load, Unless Otherwise Specified)

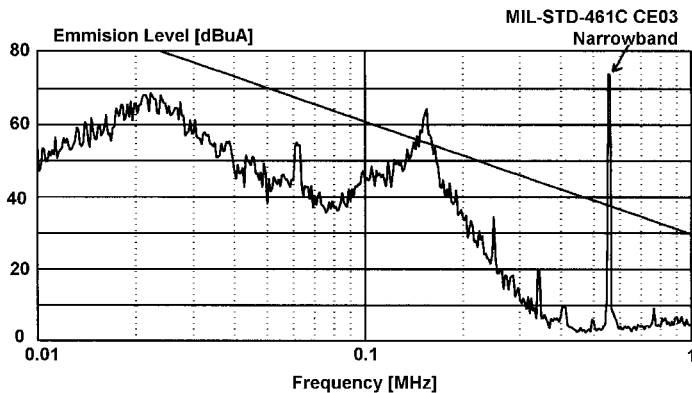

Figure 7 – MIL-STD-461C DV200-2815D Without EMI Filter

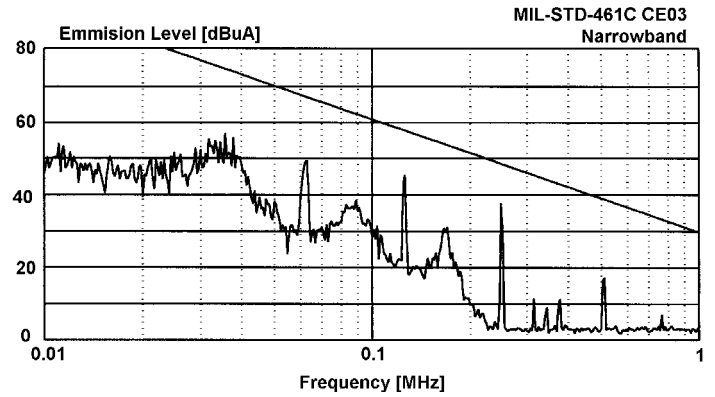

Figure 8 – MIL-STD-461C DV200-2805S With DVMN28 EMI Filter

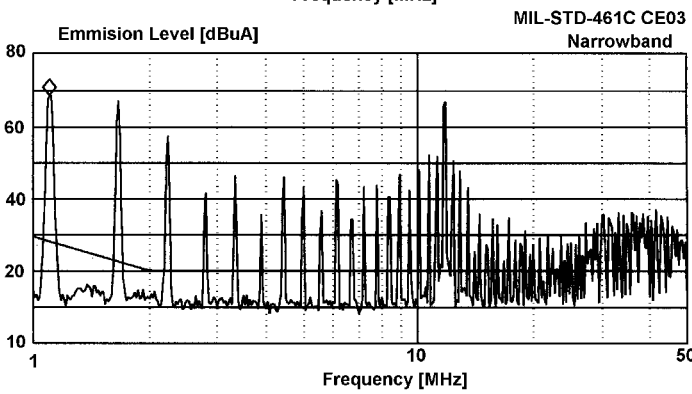
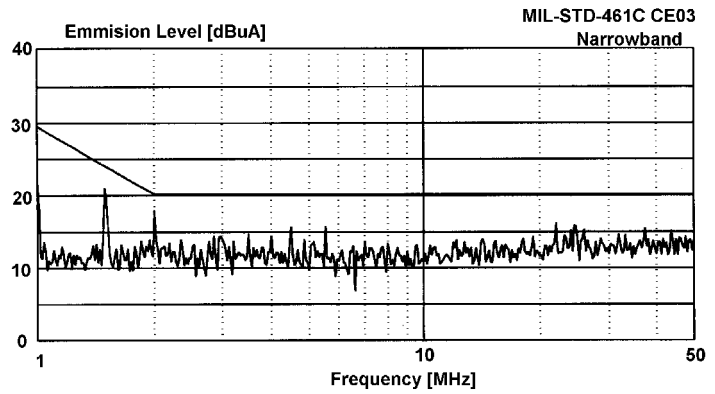
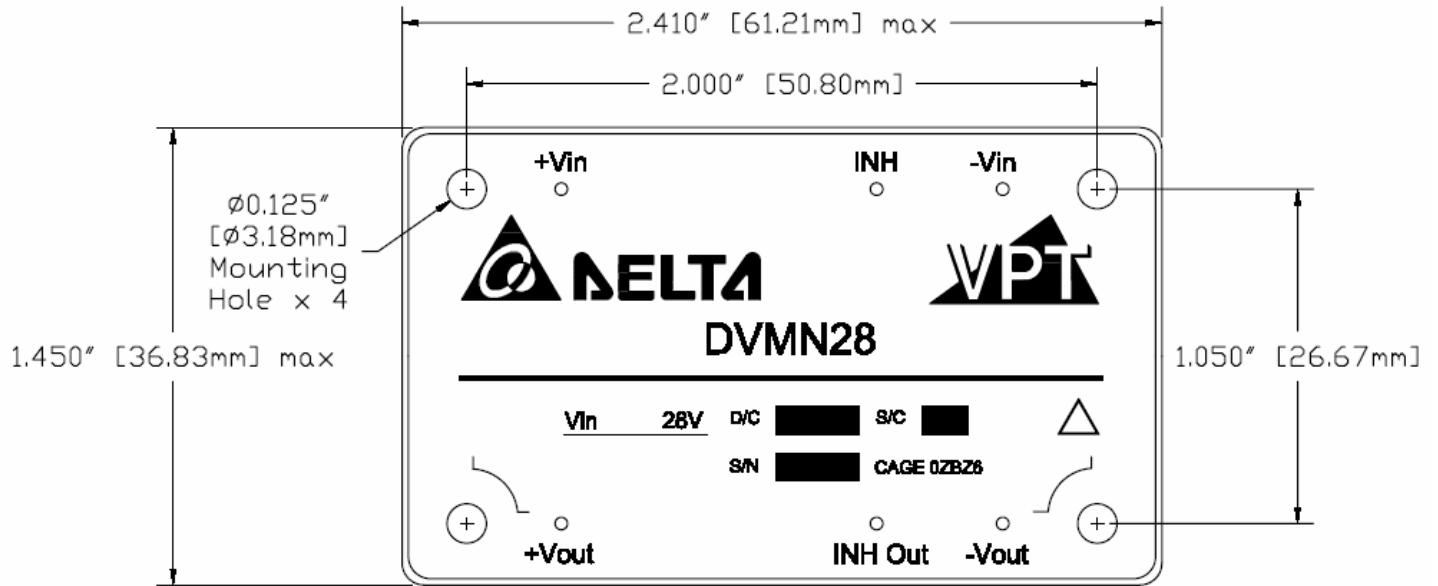

Figure 9 – MIL-STD-461D DV200-2805S With DVMN28 EMI Filter



PACKAGE SPECIFICATIONS



TOP VIEW

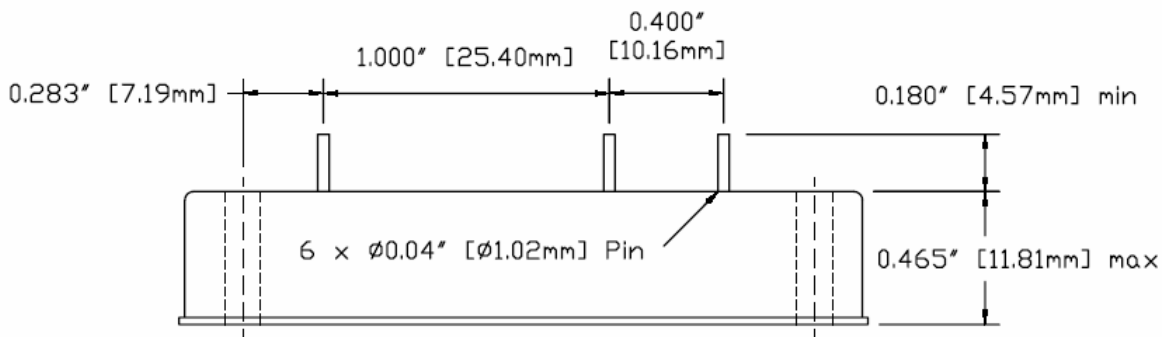

PIN	FUNCTION
1	+Vin
2	INH
3	-Vin
4	-Vout
5	INH OUT
6	+V OUT

SIDE VIEW

Figure 10 - Package and Pinout
 (Dimensional Limits are $\pm 0.005"$ Unless Otherwise Stated)

PACKAGE PIN DESCRIPTION

Pin	Function	Description
1	+Vin	28V Input: Positive Input Voltage Connection
2	INH	Logic Low = Disabled Output.
3	-Vin	Input Common Connection
4	-Vout	Output Common Connection
5	INH OUT	Output Inhibit. Open Collector Output. Connects to Load Converter INH Input.
6	+Vout	28V Output: Positive Output Voltage Connection

ENVIRONMENTAL SCREENING

Screening	MIL-STD-883	Standard (No Suffix)	Military /ML
Pre-Cap Inspection	IPC-A-610 Class II	•	•
Temperature Cycling	-55°C, 100°C, 10 cycles		•
Burn-In	96 hours at +100°C 12 hours at +100°C	•	•
Final Electrical	100% at -55°C, 25°C, 100°C ¹ 100% at 25°C	•	•
Final Inspection	Method 2009	•	•

Note: 1. 100% R&R testing at -55°C, +25°C, and +100°C with all test data included in product shipment.

ORDERING INFORMATION

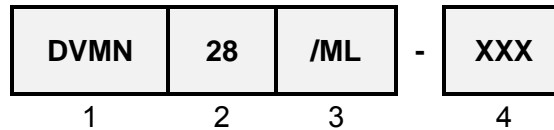

(1)	(2)		(3)		(4)
Product Series	Nominal Input Voltage		Screening Code		Additional Screening Code
DVMN	28	28 Volts	None /ML	Standard Military	Contact Sales

Please contact your sales representative or the VPT Inc. Sales Department for more information concerning additional environmental screening and testing, different input voltage, power requirement, source inspection, and/or special element evaluation for space or other higher quality applications.

CONTACT INFORMATION

To request a quotation or place an order, please contact your sales representative or the VPT Inc. Sales Department at:

Phone: (425) 353-3010
Fax: (425) 353-4030
E-mail: sales@vpt-inc.com

All information contained in this datasheet is believed to be accurate, however, no responsibility is assumed for possible errors or omissions. The products or specifications contained herein are subject to change without notice.