



T-1^{3/4} (5 mm), T-1 (3 mm), High Performance AlInGaP LED Lamps

Technical Data

SunPower Series
HLMA-CX00 Series
HLMA-DX00 Series
HLMA-KX00 Series
HLMT-CX00 Series
HLMT-DX00 Series

Features

- Outstanding LED Material Efficiency
- High Light Output over a Wide Range of Currents
- Low Electrical Power Dissipation
- CMOS/MOS Compatible
- Colors: 590/592 nm Amber, 615/617 nm and 622 nm Reddish-Orange
- Variety of Packages Available

Applications

- Outdoor Message Boards
- Safety Lighting Equipment
- Signaling Applications
- Emitter for Emitter/Detector Applications
- Changeable Message Signs
- Portable Equipment
- Medical Equipment
- Automotive Lighting
- Alternative to Incandescent Lamps

Description

These untinted, non-diffused, solid state lamps utilize the latest absorbing/transparent substrate aluminum indium gallium phosphide (AS/TS AlInGaP) LED technology. These materials have a very high luminous efficiency, capable of producing high light output over a wide range of drive currents. In addition, these LED lamps are at wavelengths ranging from amber to reddish orange and at viewing angles ranging from 7 to 45 degrees.

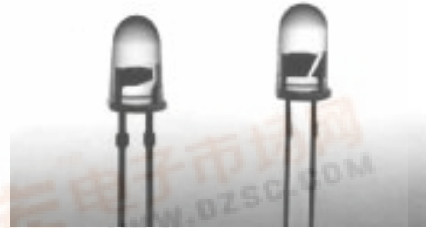

Package Dimensions

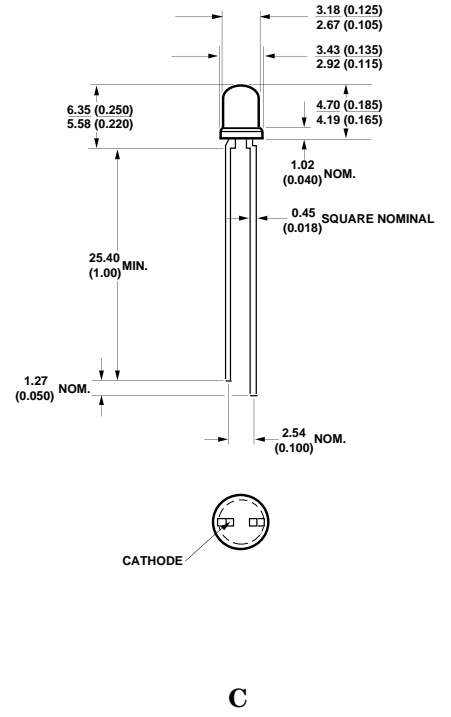
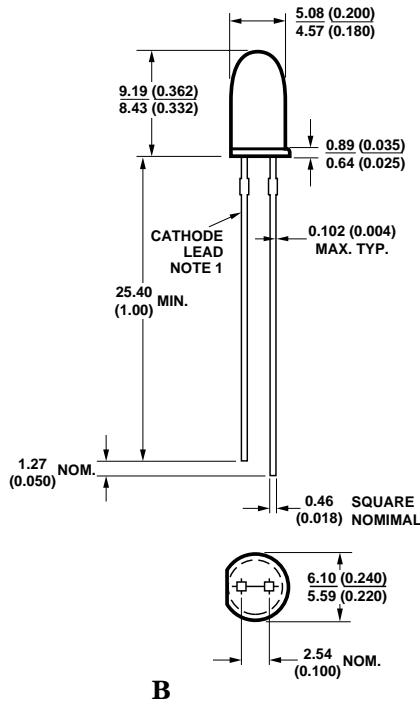
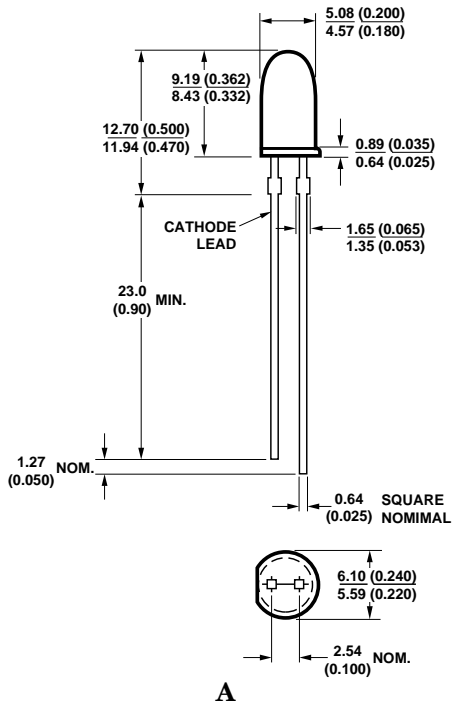

- NOTES:
 1. ALL DIMENSIONS ARE IN MILLIMETERS (INCHES).
 2. THE LEADS ARE MILD STEEL, SOLDER DIPPED.
 3. AN EPOXY MENISCUS MAY EXTEND ABOUT 1 MM (0.040") DOWN THE LEADS, UNLESS OTHERWISE NOTED.

Absolute Maximum Ratings at $T_A = 25^\circ\text{C}$

(T-1^{3/4} Package)

DC Forward Current ^[1,4,5]	50 mA
Peak Forward Current ^[2]	200 mA
Time Average Input Power ^[2]	103 mW
Transient Forward Current ^[3] (10 μs Pulse)	500 mA
Reverse Voltage ($I_R = 100 \mu\text{A}$)	5 V
Operating Temperature Range	-40 to 100°C
Storage Temperature	-40 to 120°C
Junction Temperature	130°C
Soldering Temperature	260°C for 5 seconds
	[1.59 mm (0.06 in.) below seating plane]

Notes:

1. Derate linearly as shown in Figure 4.
2. Any pulsed operation cannot exceed the Absolute Max Peak Forward Current or the Max Allowable Time Average Power as specified in Figure 5.
3. The transient peak current is the maximum nonrecurring peak current the device can withstand without damaging the LED die and wire bonds.
4. Drive Currents between 10 and 30 mA are recommended for best long term performance.
5. Operation at currents below 10 mA is not recommended, please contact your Hewlett-Packard sales representative.

Absolute Maximum Ratings at $T_A = 25^\circ\text{C}$ (T-1 Package)

DC Forward Current ^[1,4,5]	50 mA
Peak Forward Current ^[2]	200 mA
Time Average Input Power ^[2]	103 mW
Transient Forward Current ^[3] (10 μs Pulse)	500 mA
Reverse Voltage ($I_R = 100 \mu\text{A}$)	5 V
Operating Temperature Range	-40 to 100°C
Storage Temperature	-40 to 100°C
Junction Temperature	110°C
Solder Temperature	260°C for 5 seconds
	[1.59 mm (0.06 in.) below seating plane]

Notes:

1. Derate linearly as shown in Figure 4.
2. Any pulsed operation cannot exceed the Absolute Max Peak Forward Current or the Max Allowable Time Average Power as specified in Figure 5.
3. The transient peak current is the maximum nonrecurring peak current the device can withstand without damaging the LED die and wire bonds.
4. Drive Currents between 10 mA and 30 mA are recommended for best long term performance.
5. Operation at currents below 10 mA is not recommended, please contact your Hewlett-Packard sales representative.

Optical Characteristics at $T_A = 25^\circ\text{C}$

TS-AlInGaP T-1^{3/4}

Part Number HLMT-	Luminous Intensity I_V (mcd) @ 20 mA ^[1]		Peak Wavelength λ_{peak} (nm) Typ.	Color, Dominant Wavelength λ_d ^[2] (nm) Typ.	Viewing Angle $2\theta_{1/2}$ Degrees ^[3] Typ.	Luminous Efficacy η_V (lm/w)	Package Drawing
	Min.	Typ.					
CL00 ^[1]	2600	8300	594	592	8	480	A
CH00 ^[1]	2900	9000	623	617	8	263	
DL00 ^[4]	450	1500	594	592	24	480	B
DH00 ^[4]	500	1800	623	617	24	263	

Notes:

1. The luminous intensity, I_V , is measured at the peak of the spatial radiation pattern which may not be aligned with the mechanical axis of the lamp package.
2. The dominant wavelength, λ_d , is derived from the CIE Chromaticity Diagram and represents the color of the device.
3. $\theta_{1/2}$ is the off-axis angle where the luminous intensity is 1/2 the peak intensity.
4. The luminous intensity, I_V , is measured at the mechanical axis of the lamp package. The actual peak of the spatial radiation pattern may not be aligned with this axis.

AS-AlInGaP T-1^{3/4}

Part Number HLMA-	Luminous Intensity I_V (mcd) @ 20 mA ^[1]		Peak Wavelength λ_{peak} (nm) Typ.	Color, Dominant Wavelength λ_d ^[2] (nm) Typ.	Viewing Angle $2\theta_{1/2}$ Degrees ^[3] Typ.	Luminous Efficacy η_V (lm/w)	Package Drawing
	Min.	Typ.					
CL00 ^[1]	1000	3500	592	590	7	480	A
CH00 ^[1]	1000	3500	621	615	7	263	
DL00 ^[4]	300	800	592	590	24	480	B
DH00 ^[4]	290	600	621	615	24	263	
DG00 ^[4]	290	500	630	622	24	197	

Notes:

1. The luminous intensity, I_V , is measured at the peak of the spatial radiation pattern which may not be aligned with the mechanical axis of the lamp package.
2. The dominant wavelength, λ_d , is derived from the CIE Chromaticity Diagram and represents the color of the device.
3. $\theta_{1/2}$ is the off-axis angle where the luminous intensity is 1/2 the peak intensity.
4. The luminous intensity, I_V , is measured at the mechanical axis of the lamp package. The actual peak of the spatial radiation pattern may not be aligned with this axis.

AS-AlInGaP T-1

Part Number HLMA-	Luminous Intensity I_V (mcd) @ 20 mA ^[1]		Peak Wavelength λ_{peak} (nm) Typ.	Color, Dominant Wavelength λ_d ^[2] (nm) Typ.	Viewing Angle $2\theta_{1/2}$ Degrees ^[3] Typ.	Luminous Efficacy η_V (lm/w)	Package Drawing
	Min.	Typ.					
KL00	35	200	592	590	45	480	C
KH00	35	200	621	615	45	263	

Notes:

1. The luminous intensity, I_V , is measured at the mechanical axis of the lamp package. The actual peak of the spatial radiation pattern may not be aligned with this axis.
2. The dominant wavelength, λ_d , is derived from the CIE Chromaticity Diagram and represents the color of the device.
3. $\theta_{1/2}$ is the off-axis angle where the luminous intensity is 1/2 the peak intensity.

Electrical Characteristics at $T_A = 25^\circ\text{C}$

TS-AlInGaP T-1^{3/4}

Part Number HLMT-	Forward Voltage V_F (Volts) @ $I_F = 20\text{ mA}$		Reverse Breakdown V_R (Volts) @ $I_R = 100\ \mu\text{A}$		Capacitance C (pF) $V_F = 0,$ $f = 1\text{ MHz}$ Typ.	Thermal Resistance $R_{\theta_{J-PIN}}$ ($^\circ\text{C/W}$)	Speed of Response τ_s (ns) Time Constant e^{-t/τ_s} Typ.
	Typ.	Max.	Min.	Typ.			
CL00	2.0	2.4	5	25	70	210	13
CH00	2.0	2.4	5	25	70	210	13
DL00	2.0	2.4	5	25	70	260	13
DH00	2.0	2.4	5	25	70	260	13

AS-AlInGaP T-1^{3/4}

Part Number HLMA-	Forward Voltage V_F (Volts) @ $I_F = 20\text{ mA}$		Reverse Breakdown V_R (Volts) @ $I_R = 100\ \mu\text{A}$		Capacitance C (pF) $V_F = 0,$ $f = 1\text{ MHz}$ Typ.	Thermal Resistance $R_{\theta_{J-PIN}}$ ($^\circ\text{C/W}$)	Speed of Response τ_s (ns) Time Constant e^{-t/τ_s} Typ.
	Typ.	Max.	Min.	Typ.			
CL00	1.9	2.4	5	25	40	210	13
CH00	1.9	2.4	5	25	40	210	13
DL00	1.9	2.4	5	25	40	260	13
DH00	1.9	2.4	5	25	40	260	13
DG00	1.9	2.4	5	25	40	260	13

AS-AlInGaP T-1

Part Number HLMA-	Forward Voltage V_F (Volts) @ $I_F = 20\text{ mA}$		Reverse Breakdown V_R (Volts) @ $I_R = 100\ \mu\text{A}$		Capacitance C (pF) $V_F = 0,$ $f = 1\text{ MHz}$ Typ.	Thermal Resistance $R_{\theta_{J-PIN}}$ ($^\circ\text{C/W}$)	Speed of Response τ_s (ns) Time Constant e^{-t/τ_s} Typ.
	Typ.	Max.	Min.	Typ.			
KL00	1.9	2.4	5	25	40	290	13
KH00	1.9	2.4	5	25	40	290	13

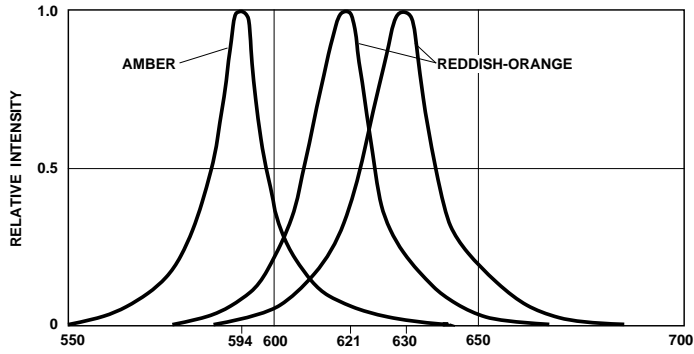

Figure 1. Relative Intensity vs. Wavelength.

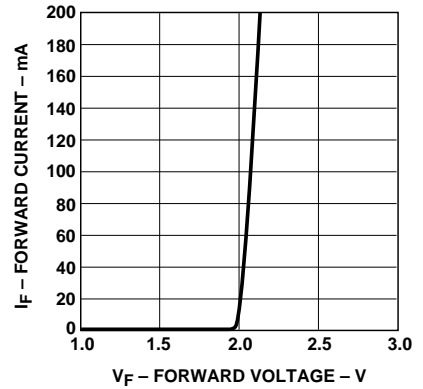

Figure 2a. Forward Current vs. Forward Voltage, AS-AlInGaP.

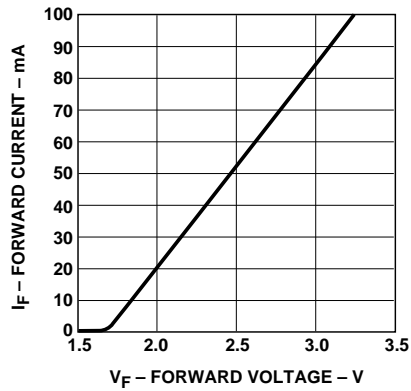

Figure 2b. Forward Current vs. Forward Voltage, TS-AlInGaP.

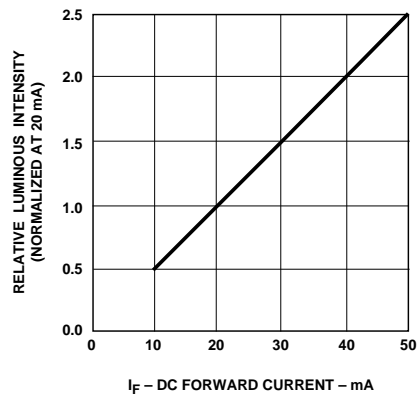

Figure 3. Relative Luminous Intensity vs. Forward Current. Derating Based on T_{jMAX} .

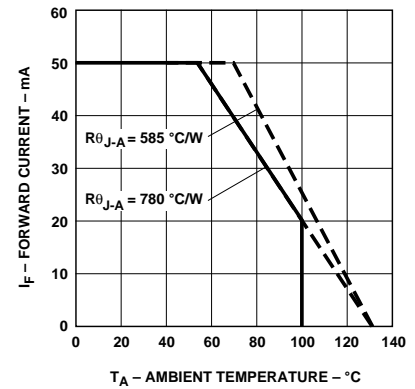

Figure 4a. Maximum DC Current vs. Ambient Temperature for AS T-1^{3/4} Lamps. Derating Based on $T_{jMAX} = 130^{\circ}C$.

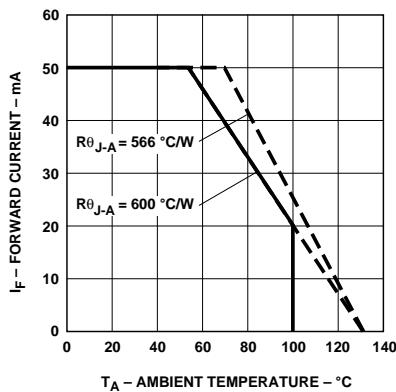

Figure 4b. Maximum DC Current vs. Ambient Temperature for TS T-1^{3/4} Lamps. Derating Based on $T_{jMAX} = 130^{\circ}C$.

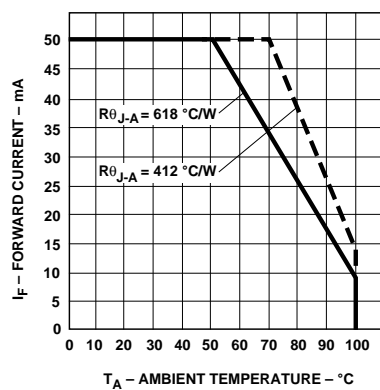

Figure 4c. Maximum Forward Current vs. Ambient Temperature for T-1 Lamps. Derating Based on $T_{jMax} = 110^{\circ}C$.

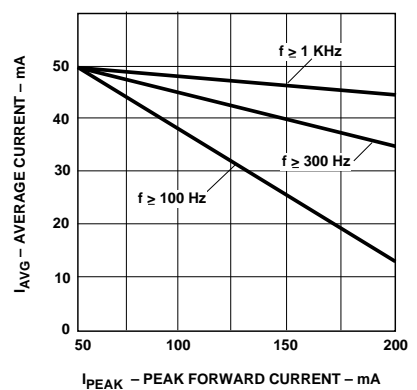

Figure 5. Maximum Average Current vs. Peak Forward Current.

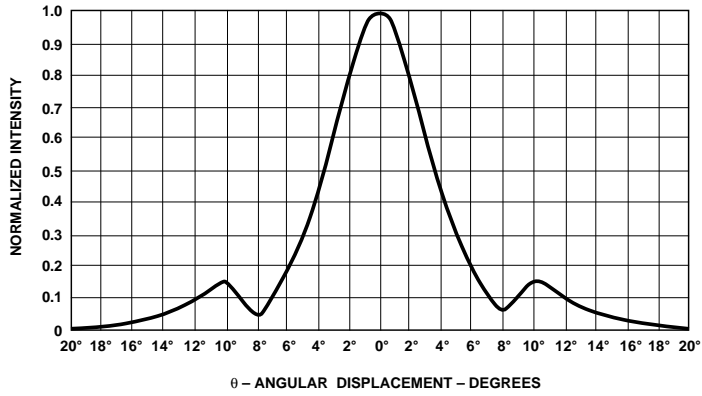

Figure 6. Normalized Luminous Intensity vs. Angular Displacement, HLMT-CH00/CL00.

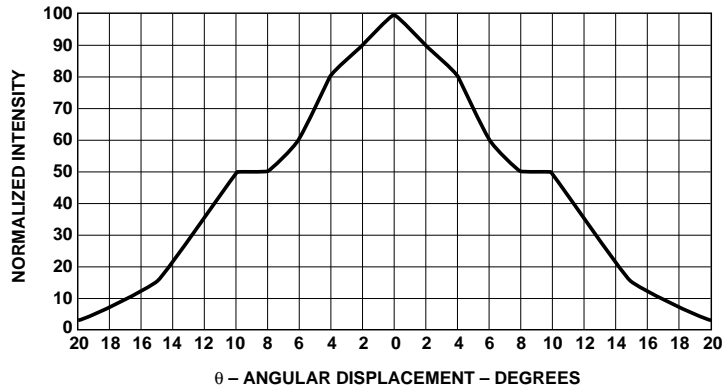

Figure 7. Normalized Luminous Intensity vs. Angular Displacement, HLMA-DG00/-DH00/-DL00.

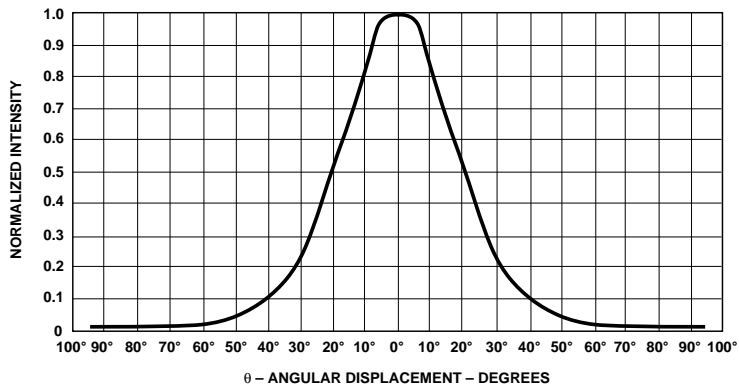

Figure 8. Normalized Luminous Intensity vs. Angular Displacement, HLMA-KH00/-KL00.