



# Si4376DY

## Vishay Siliconix

### Dual N-Channel 30-V (D-S) MOSFET with Schottky Diode

PRODUCT SUMMARY			
	V <sub>DS</sub> (V)	r <sub>DS(on)</sub> (Ω)	I <sub>D</sub> (A)
Channel-1	30	0.020 @ V <sub>GS</sub> = 10 V	7.5
		0.0275 @ V <sub>GS</sub> = 4.5 V	6.5
Channel-2		0.019 @ V <sub>GS</sub> = 10 V	7.5
		0.023 @ V <sub>GS</sub> = 4.5 V	6.5

SCHOTTKY PRODUCT SUMMARY		
V <sub>DS</sub> (V)	V <sub>SD</sub> (V) Diode Forward Voltage	I <sub>F</sub> (A)
30	0.50 V @ 1.0 A	2.0

#### FEATURES

- LITTLE FOOT® Plus Schottky
- Si4830DY Pin Compatible
- PWM Optimized
- 100% R<sub>G</sub> Tested

#### APPLICATIONS

- Asymmetrical Buck-Boost DC/DC Converter

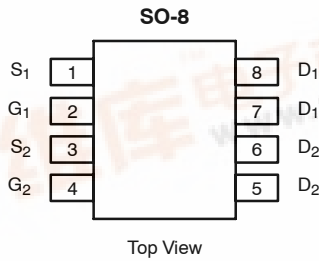

Ordering Information: Si4376DY  
Si4376DY-T1 (with Tape and Reel)

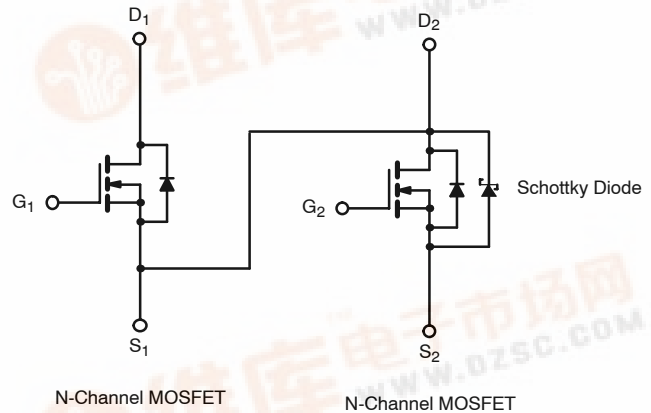

ABSOLUTE MAXIMUM RATINGS (T <sub>A</sub> = 25 °C UNLESS OTHERWISE NOTED)						
Parameter	Symbol	10 secs		Steady State		Unit
		Channel-1	Channel-2	Channel-1	Channel-2	
Drain-Source Voltage	V <sub>DS</sub>	30				V
Gate-Source Voltage	V <sub>GS</sub>	±20	±12	±20	±12	
Continuous Drain Current (T <sub>J</sub> = 150 °C) <sup>a</sup>	I <sub>D</sub>	T <sub>A</sub> = 25 °C		5.7		A
		T <sub>A</sub> = 70 °C		4.6		
Pulsed Drain Current	I <sub>DM</sub>	30				
Continuous Source Current (Diode Conduction) <sup>a</sup>	I <sub>S</sub>	1.7		0.9		
Maximum Power Dissipation <sup>a</sup>	P <sub>D</sub>	T <sub>A</sub> = 25 °C		1.1		W
		T <sub>A</sub> = 70 °C		0.7		
Operating Junction and Storage Temperature Range	T <sub>J</sub> , T <sub>stg</sub>	-55 to 150				°C

THERMAL RESISTANCE RATINGS							
Parameter	Symbol	MOSFET		Schottky		Unit	
		Typ	Max	Typ	Max		
Maximum Junction-to-Ambient <sup>a</sup>	R <sub>thJA</sub>	t ≤ 10 sec	52	62.5	53	62.5	°C/W
		Steady-State	93	110	93	110	
Maximum Junction-to-Foot (Drain)	R <sub>thJF</sub>	Steady-State	35	40	35	40	

Notes:  
a. Surface Mounted on 1" x 1" FR4 Board.



<b>MOSFET SPECIFICATIONS (T<sub>J</sub> = 25 °C UNLESS OTHERWISE NOTED).</b>								
Parameter	Symbol	Test Condition	Min	Typ <sup>a</sup>	Max	Unit		
<b>Static</b>								
Gate Threshold Voltage	V <sub>GS(th)</sub>	V <sub>DS</sub> = V <sub>GS</sub> , I <sub>D</sub> = 250 μA	Ch-1	1.0		3.0	V	
			Ch-2	0.8		2.0		
Gate-Body Leakage	I <sub>GSS</sub>	V <sub>DS</sub> = 0 V, V <sub>GS</sub> = ±20 V	Ch-1			±100	nA	
		V <sub>DS</sub> = 0 V, V <sub>GS</sub> = ±12 V	Ch-2			±100		
Zero Gate Voltage Drain Current	I <sub>DSS</sub>	V <sub>DS</sub> = 24 V, V <sub>GS</sub> = 0 V	Ch-1			1	μA	
			Ch-2			100		
		V <sub>DS</sub> = 24 V, V <sub>GS</sub> = 0 V, T <sub>J</sub> = 85 °C	Ch-1			15		
			Ch-2			2000		
On-State Drain Current <sup>b</sup>	I <sub>D(on)</sub>	V <sub>DS</sub> = 5 V, V <sub>GS</sub> = 10 V	Ch-1	20			A	
			Ch-2	20				
Drain-Source On-State Resistance <sup>b</sup>	r <sub>DS(on)</sub>	V <sub>GS</sub> = 10 V, I <sub>D</sub> = 7.5 A	Ch-1		0.016	0.020	Ω	
			Ch-2		0.015	0.019		
		V <sub>GS</sub> = 4.5 V, I <sub>D</sub> = 6.5 A	Ch-1		0.022	0.0275		
			Ch-2		0.018	0.023		
Forward Transconductance <sup>b</sup>	g <sub>fs</sub>	V <sub>DS</sub> = 15 V, I <sub>D</sub> = 7.5 A	Ch-1		30		S	
			Ch-2		30			
Diode Forward Voltage <sup>b</sup>	V <sub>SD</sub>	I <sub>S</sub> = 1 A, V <sub>GS</sub> = 0 V	Ch-1		0.75	1.2	V	
			Ch-2		0.47	0.5		
<b>Dynamic<sup>a</sup></b>								
Total Gate Charge	Q <sub>g</sub>	V <sub>DS</sub> = 15 V, V <sub>GS</sub> = 4.5 V, I <sub>D</sub> = 7.5 A	Ch-1		9	14	nC	
			Ch-2		12.5	20		
Gate-Source Charge	Q <sub>gs</sub>		Ch-1		3.8			
			Ch-2		4.0			
Gate-Drain Charge	Q <sub>gd</sub>		Ch-1		3.1			
			Ch-2		3.2			
Gate Resistance	R <sub>g</sub>		Ch-1	0.5	1.3	2.0	Ω	
			Ch-2	0.5	1.3	1.8		
Turn-On Delay Time	t <sub>d(on)</sub>		V <sub>DD</sub> = 15 V, R <sub>L</sub> = 15 Ω I <sub>D</sub> ≅ 1 A, V <sub>GEN</sub> = 10 V, R <sub>G</sub> = 6 Ω	Ch-1		12	18	ns
				Ch-2		12	20	
Rise Time	t <sub>r</sub>	Ch-1			11	17		
		Ch-2			11	17		
Turn-Off Delay Time	t <sub>d(off)</sub>	Ch-1			27	40		
		Ch-2			40	66		
Fall Time	t <sub>f</sub>	Ch-1			9	14		
		Ch-2			10	15		
Source-Drain Reverse Recovery Time	t <sub>rr</sub>	I <sub>F</sub> = 1.7 A, di/dt = 100 A/μs		Ch-1		35	55	
				Ch-2		28	45	

- Notes  
a. Guaranteed by design, not subject to production testing.  
b. Pulse test; pulse width ≤ 300 μs, duty cycle ≤ 2%.

<b>SCHOTTKY SPECIFICATIONS (T<sub>J</sub> = 25 °C UNLESS OTHERWISE NOTED)</b>							
Parameter	Symbol	Test Condition	Min	Typ	Max	Unit	
Forward Voltage Drop	V <sub>F</sub>	I <sub>F</sub> = 1.0 A		0.47	0.50	V	
		I <sub>F</sub> = 1.0 A, T <sub>J</sub> = 125 °C		0.36	0.42		
Maximum Reverse Leakage Current	I <sub>rm</sub>	V <sub>r</sub> = 30 V		0.004	0.100	mA	
		V <sub>r</sub> = 30 V, T <sub>J</sub> = 100 °C		0.7	10		
Junction Capacitance	C <sub>T</sub>	V <sub>r</sub> = -30 V, T <sub>J</sub> = 125 °C		3.0	20	pF	
		V <sub>r</sub> = 10 V		50			



**TYPICAL CHARACTERISTICS (25°C UNLESS NOTED)**

**MOSFET CHANNEL-1**

**Output Characteristics**

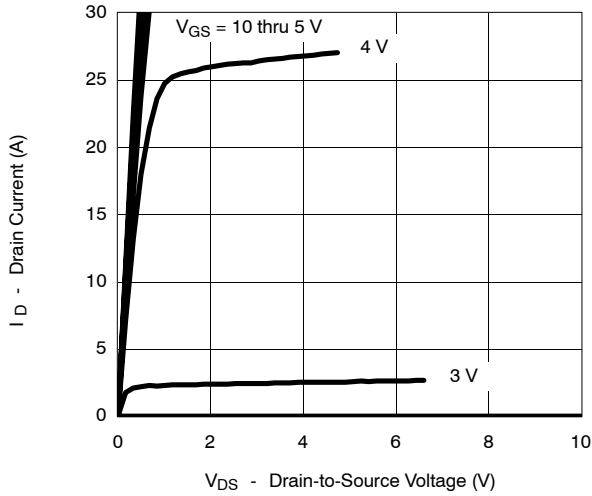

**Transfer Characteristics**

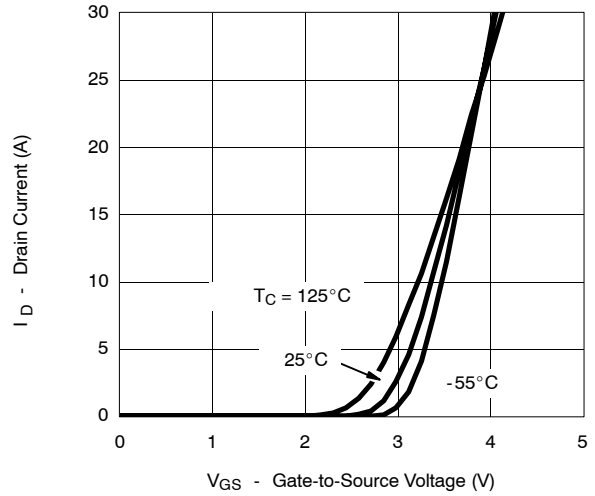

**On-Resistance vs. Drain Current**

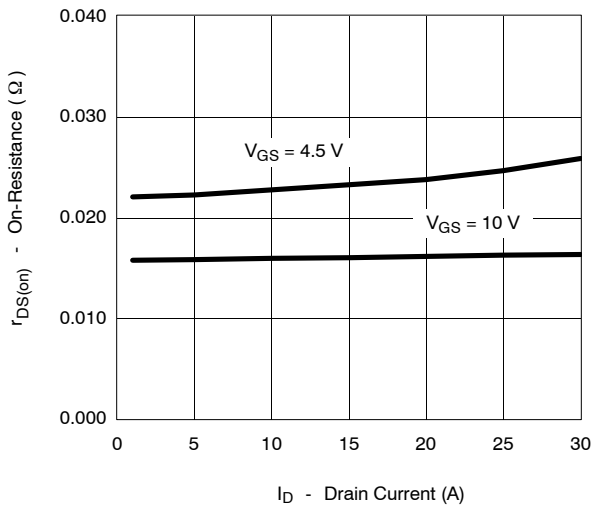

**Capacitance**

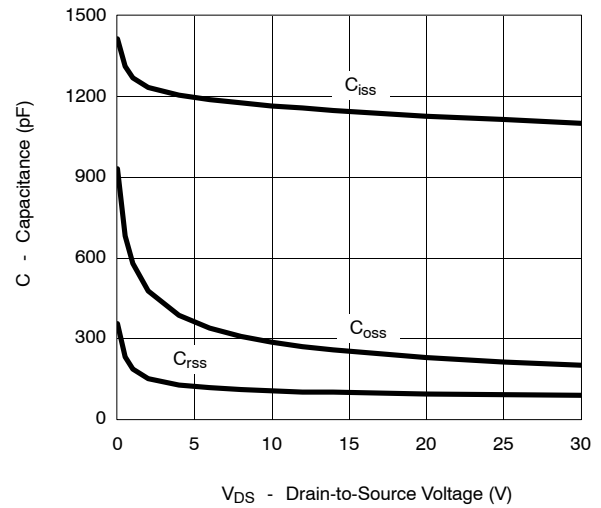

**Gate Charge**

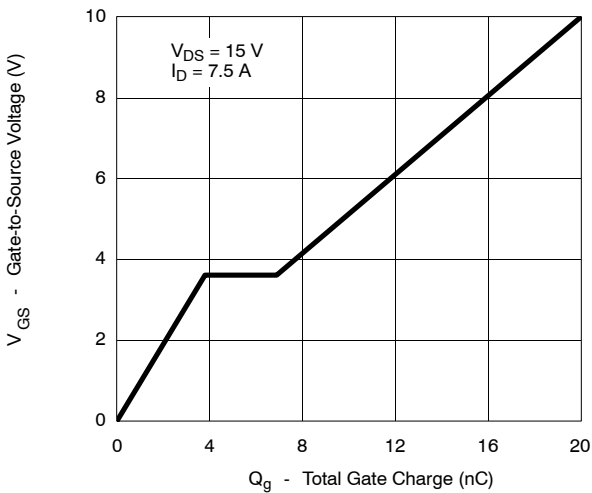

**On-Resistance vs. Junction Temperature**

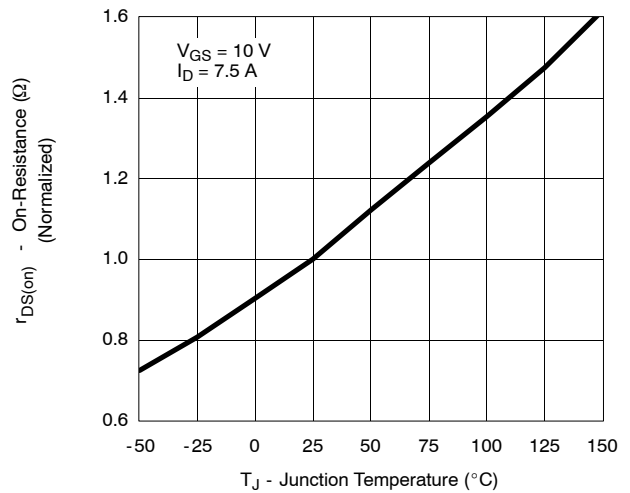

**TYPICAL CHARACTERISTICS (25 °C UNLESS NOTED)**

**MOSFET CHANNEL-1**

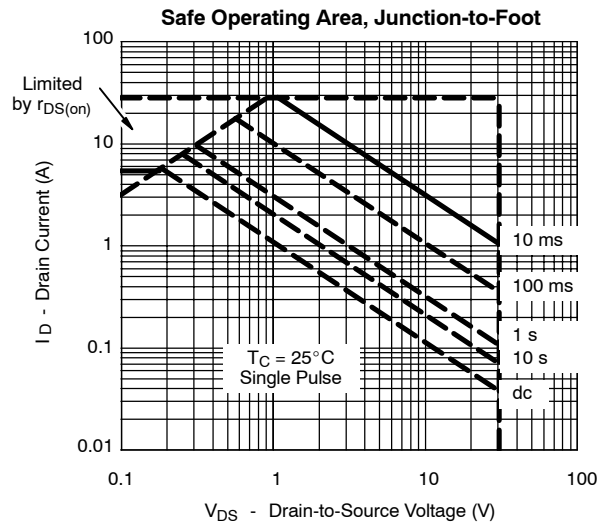
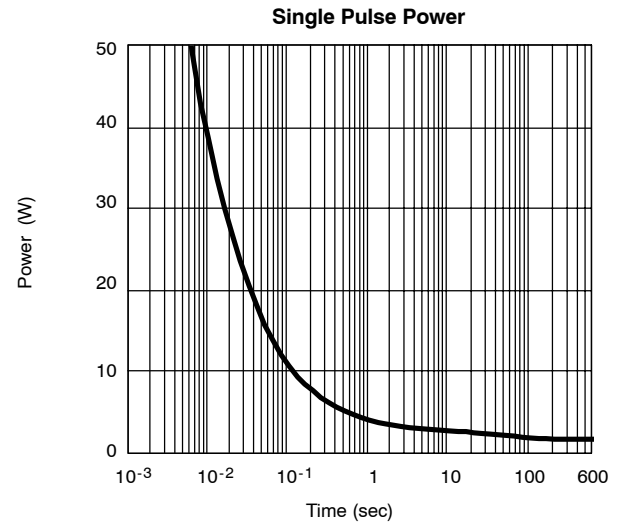
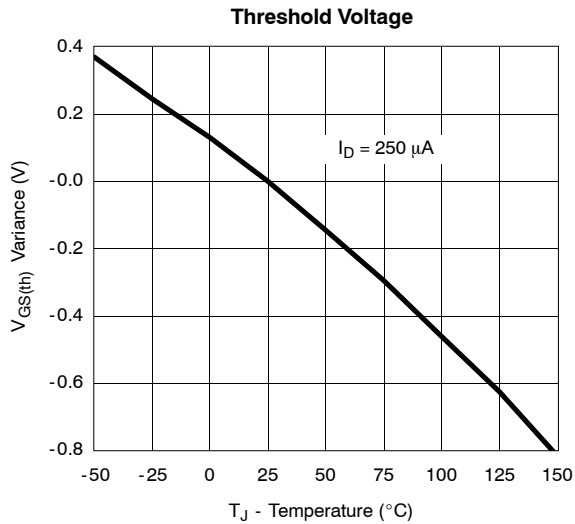
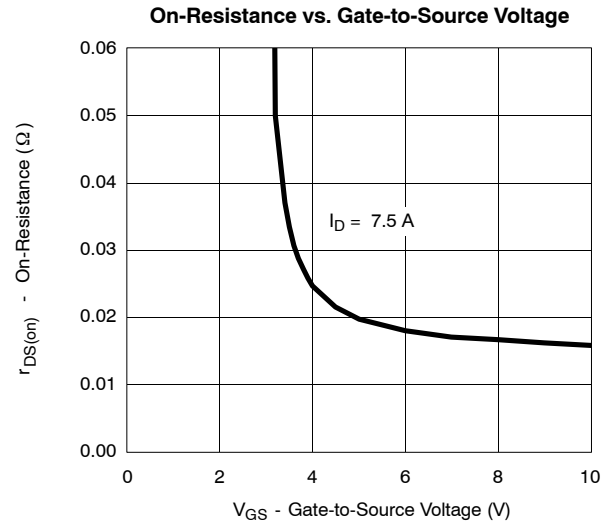
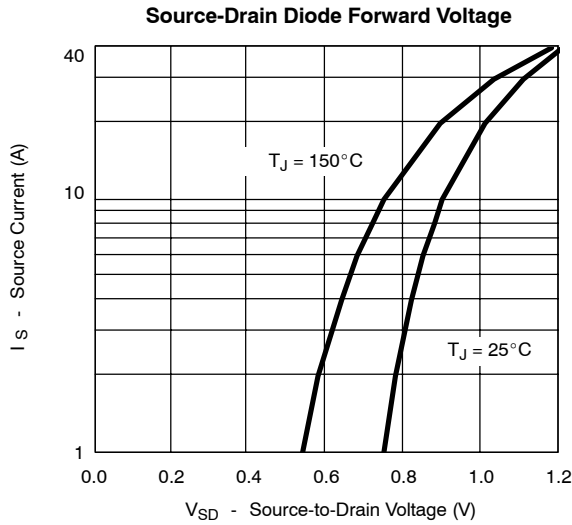



**TYPICAL CHARACTERISTICS (25°C UNLESS NOTED)**

**MOSFET CHANNEL 1**

**Normalized Thermal Transient Impedance, Junction-to-Ambient**

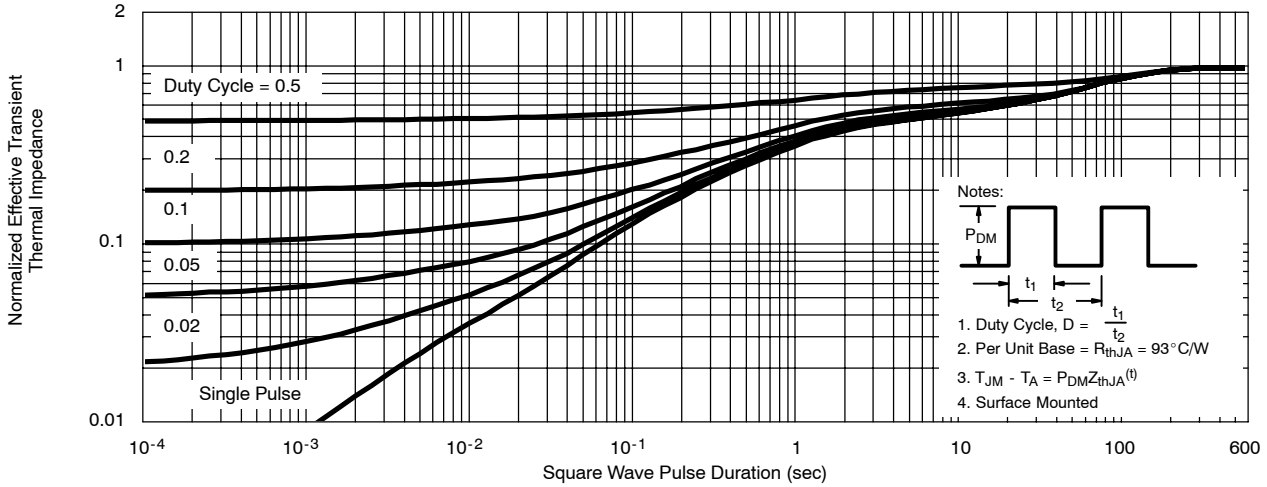

**Normalized Thermal Transient Impedance, Junction-to-Foot**

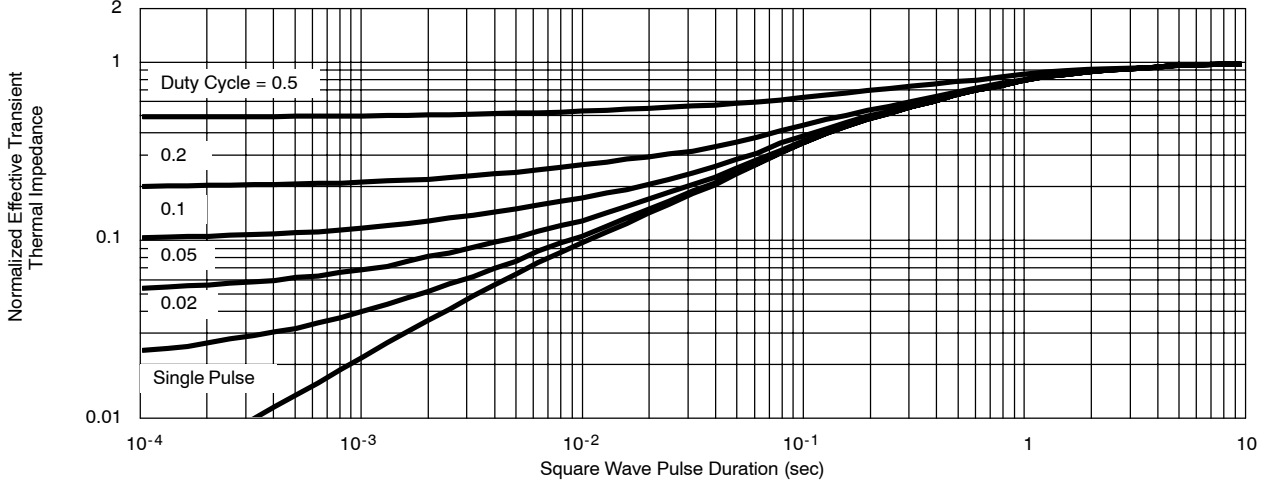

**TYPICAL CHARACTERISTICS (25°C UNLESS NOTED)**

**MOSFET CHANNEL-2**

**Output Characteristics**

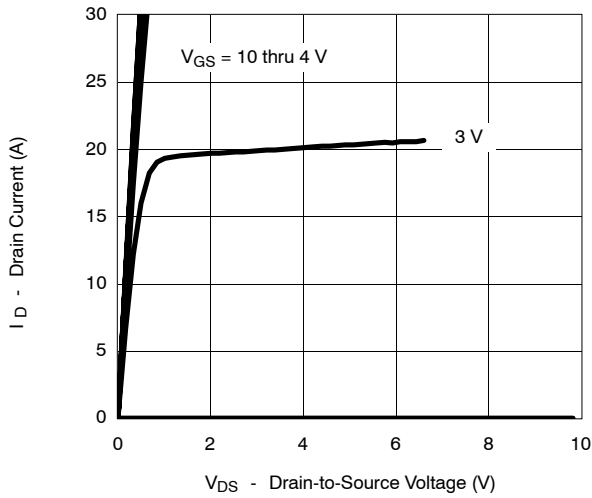

**Transfer Characteristics**

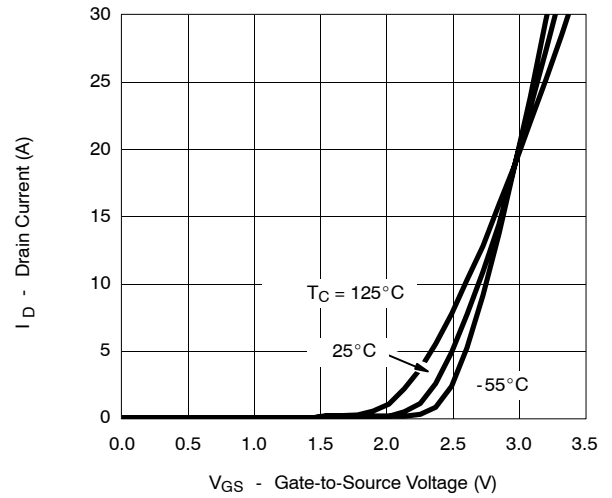

**On-Resistance vs. Drain Current**

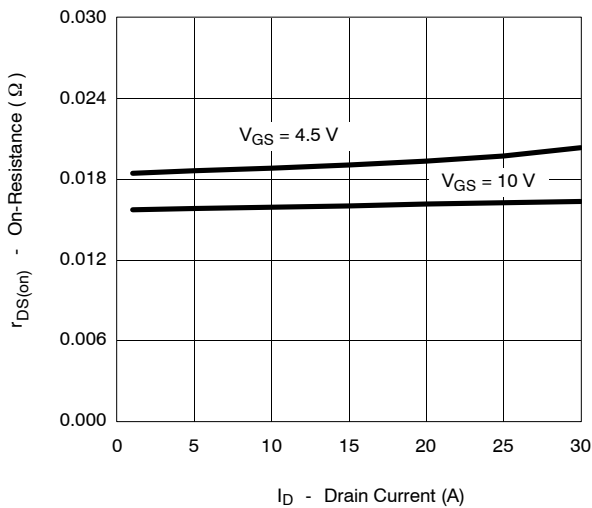

**Capacitance**

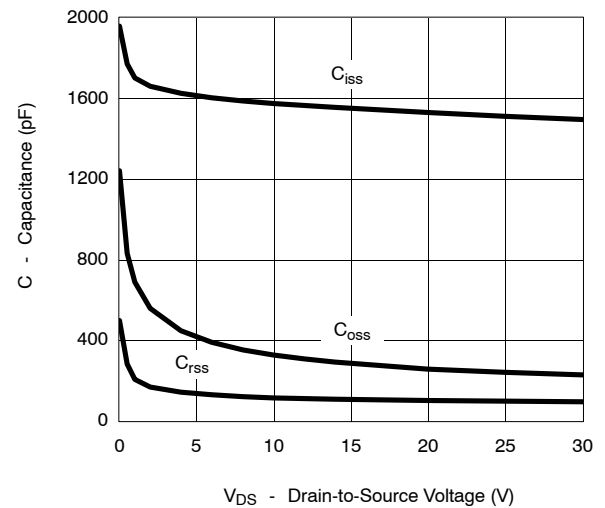

**Gate Charge**

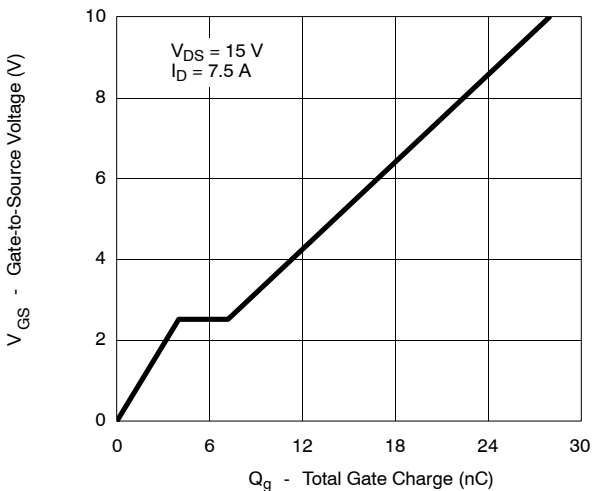

**On-Resistance vs. Junction Temperature**

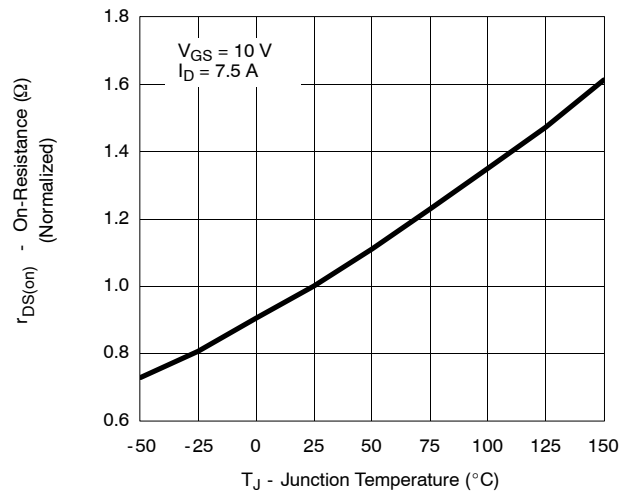



**TYPICAL CHARACTERISTICS (25°C UNLESS NOTED)**

**MOSFET CHANNEL-2**

**Source-Drain Diode Forward Voltage**

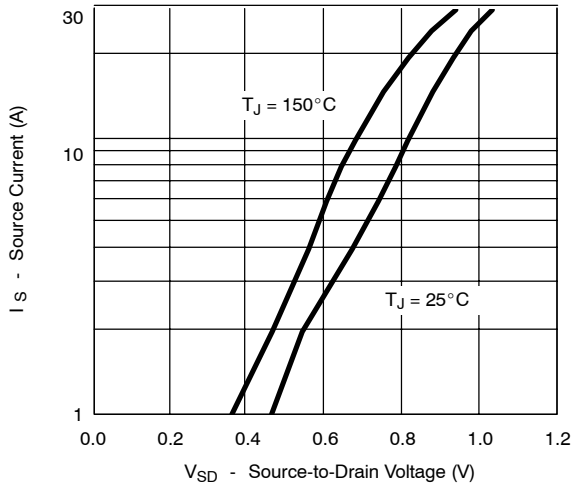

**On-Resistance vs. Gate-to-Source Voltage**

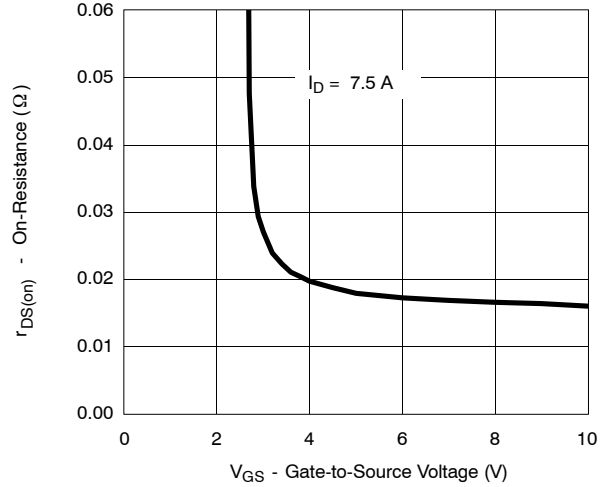

**Threshold Voltage**

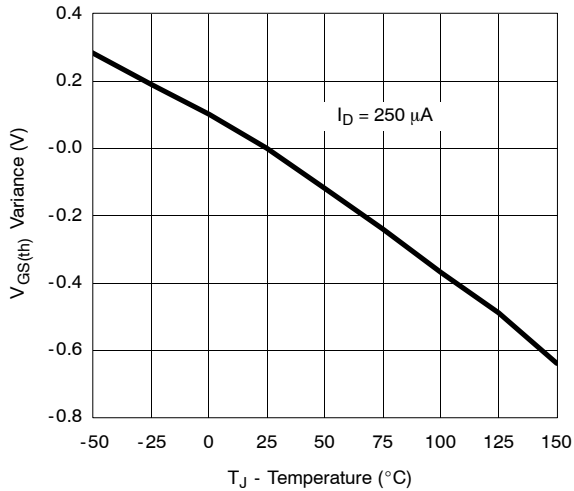

**Single Pulse Power**

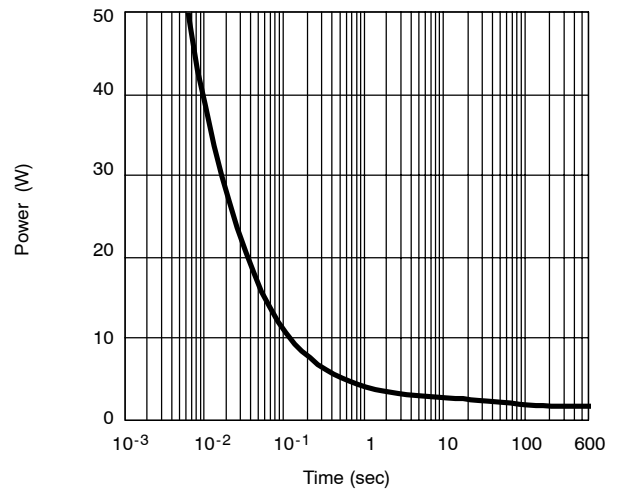

**Safe Operating Area, Junction-to-Foot**

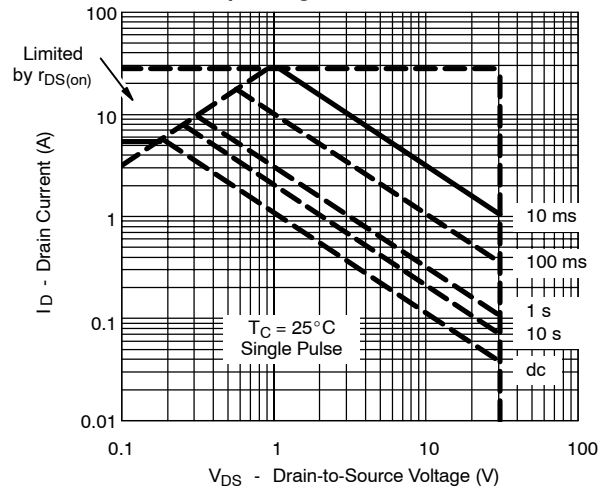

**TYPICAL CHARACTERISTICS (25°C UNLESS NOTED)**

**MOSFET CHANNEL-2**

**Normalized Thermal Transient Impedance, Junction-to-Ambient**

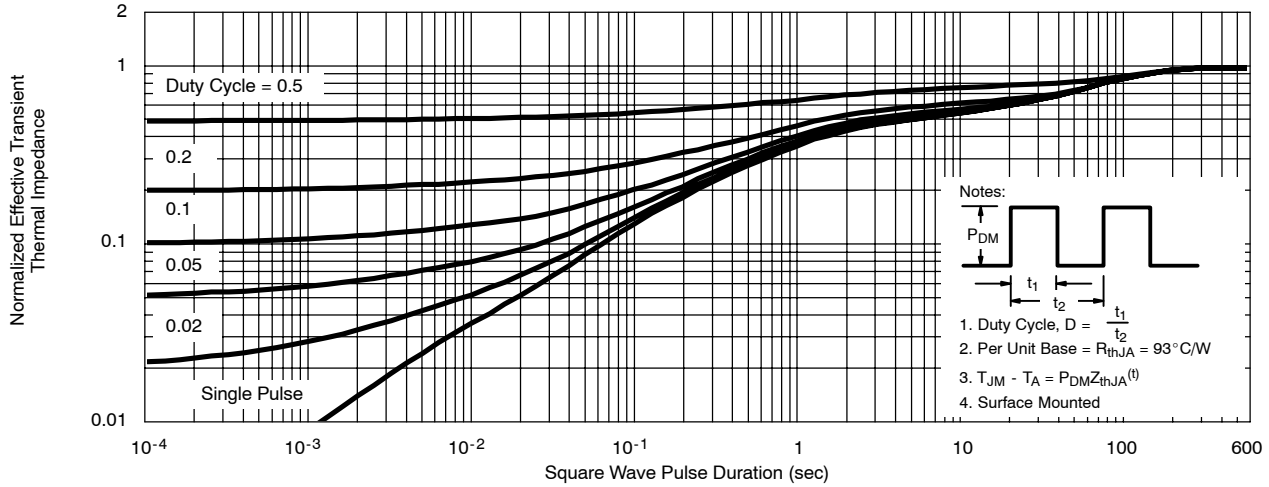

**Normalized Thermal Transient Impedance, Junction-to-Foot**

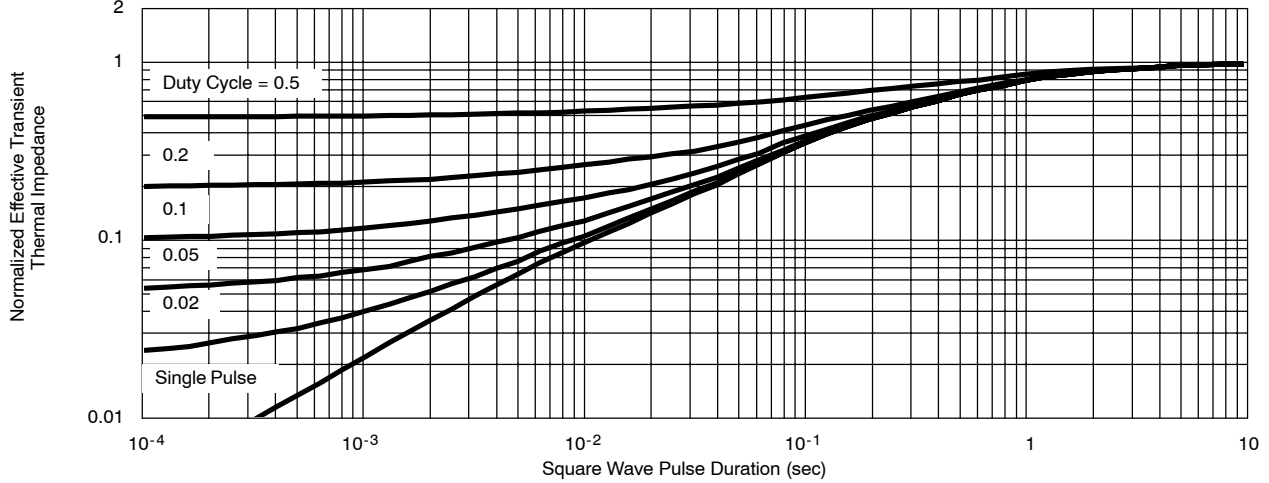





**TYPICAL CHARACTERISTICS (25°C UNLESS NOTED)**

**SCHOTTKY**

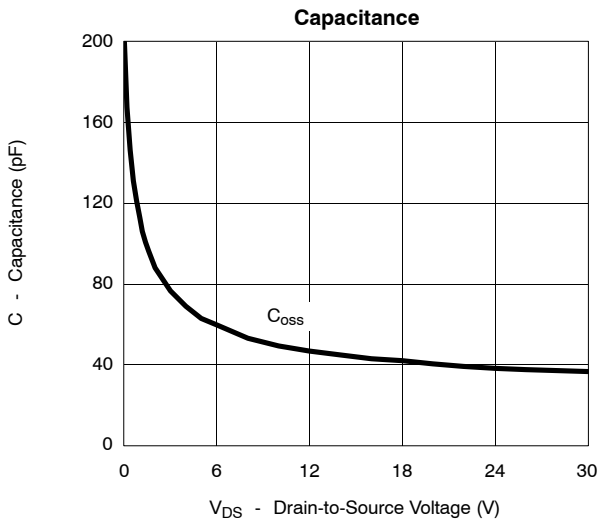
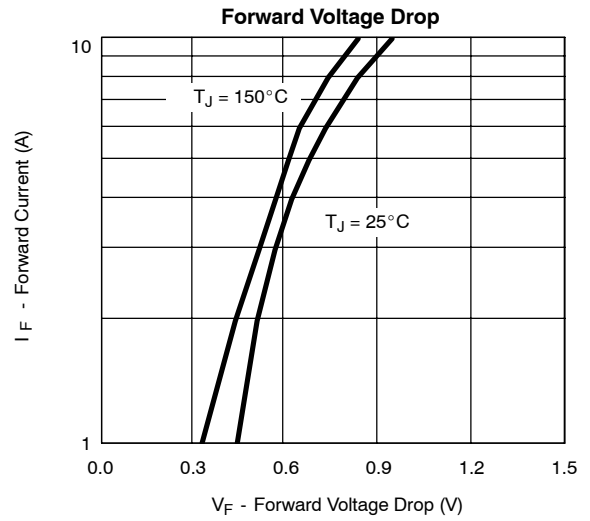
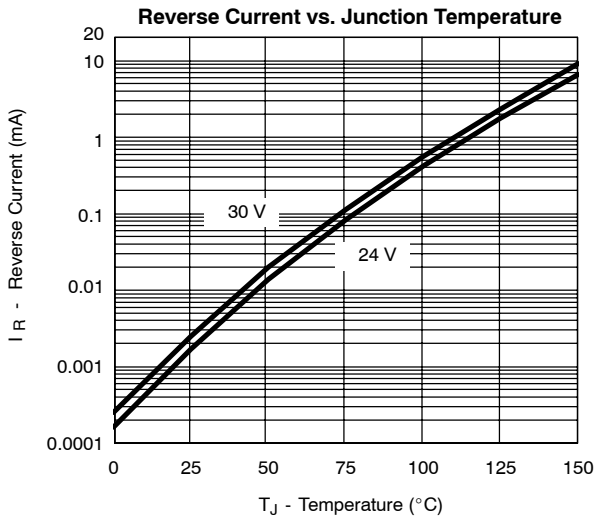



### Notice

Specifications of the products displayed herein are subject to change without notice. Vishay Intertechnology, Inc., or anyone on its behalf, assumes no responsibility or liability for any errors or inaccuracies.

Information contained herein is intended to provide a product description only. No license, express or implied, by estoppel or otherwise, to any intellectual property rights is granted by this document. Except as provided in Vishay's terms and conditions of sale for such products, Vishay assumes no liability whatsoever, and disclaims any express or implied warranty, relating to sale and/or use of Vishay products including liability or warranties relating to fitness for a particular purpose, merchantability, or infringement of any patent, copyright, or other intellectual property right.

The products shown herein are not designed for use in medical, life-saving, or life-sustaining applications. Customers using or selling these products for use in such applications do so at their own risk and agree to fully indemnify Vishay for any damages resulting from such improper use or sale.