

128-Bit IDIC[®] for Radio Frequency Identification

Description

The e5530 is part of a closed coupled identification system. It receives power from an RF transmitter which is coupled inductively to the IDIC[®]. The frequency is typically 100 to 450 kHz. Receiving RF, the IDIC[®] responds with a data stream by damping the incoming RF

via an internal load. This damping-in-turn can be detected by the interrogator. The identifying data are stored in a 128 bit PROM on the e5530, realized as an array of laser-programmable fuses. The logic block diagram for the e5530 is shown in figure 2. The data are output bit-serially as a code of length 128, 96, 64 or 32 bits. The chips are factory-programmed with a unique code.

Features

- Low power, low voltage CMOS
- Rectifier, voltage limiter, clock extraction on-chip (no battery)
- Small size
- Factory laser programmable ROM
- Operating temperature range -40 to +125°C
- Radio Frequency (RF): 100 to 450 kHz
- Transmission options
Code length: 128, 96, 64, 32 bits

Bitrate [bit/s]: RF/8, RF/16, RF/32, RF/40, RF/50, RF/64, RF/80, RF/100, RF/128, RF/256

Modulation: FSK, PSK, BIPH, Manchester BIPH-FSK

Application

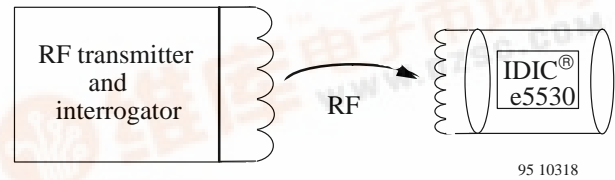

Figure 1. Application

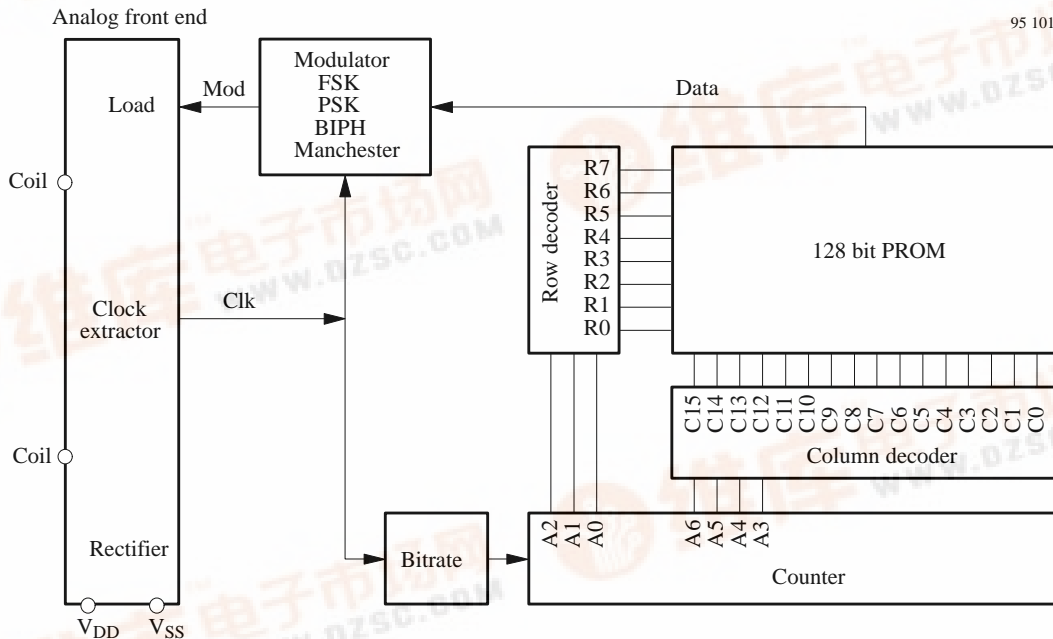

Figure 2. Block diagram

IDIC[®] stands for **ID**entification **I**ntegrated **C**ircuit and is a trademark of TEMIC.



Ordering Information

Extended Type Number	Package	Checksum	Header	IP Code	SPQ (Minimum Volume)	Minimum Order Volume
e5530H-232-DOW e5530H-232-DIT e5530H-232-S8	DOW DIT SO8	no checksum	E6	fixed and unique code	10 kpcs 10 kpcs 1120	10 kpcs 10 kpcs 1120
e5530H-zzz-DOW * e5530H-zzz-DIT * e5530H-zzz-S8 *	DOW DIT SO8	defined by customer				> 600 kpcs p.a. > 600 kpcs p.a. > 400 kpcs p.a.

- * 1) Definition of customized part number basing on orders for first year volume (300 kpcs)
 2) Definition of header, ID code, checksum etc. according to customers data base
 3) 8.000 US\$ initial cost for metal mask
 4) Lead time 5 month
 5) Low volume customized application can be covered by TK5550F-PP programming.
 With identical features of TK5530H-zzz-pPP possible

Chip Dimensions

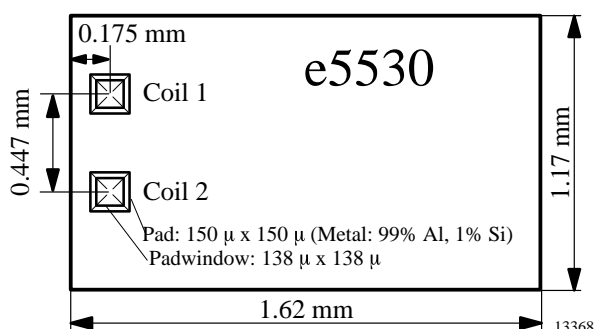
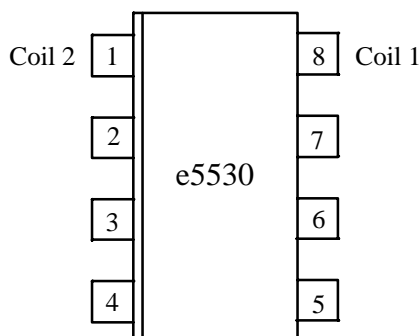

Figure 3. Chip size

Pads

Name	Pad Window	Function
Coil1	138 × 138 μm ²	1st coil pad
Coil2	138 × 138 μm ²	2nd coil pad



Note: Pins 2 to 7 have to be open. They are not specified for applications

Figure 4. Pinning SO8

Functional Description

Read Operation

Once the IC detects the incoming RF, the IC repetively reads out the code data as long as the RF signal is applied. The transition from the last bit to bit 1 of the next sequence occurs without interruption. Data is transmitted by alternating damping of the incoming RF via a load. Different kinds of modulation and bitrates are optionally available.

Rectifier

For internal power supply, an on-chip bridge rectifier is used which consists of two diodes and two n-channel transistors. A Zener diode, which protects the circuit against overvoltage on the coil inputs, and a smoothing capacitor for the internal supply are also provided.

Damping Load

Incoming RF will be damped by the power consumption of the IC itself and by an internal load, which is controlled by the modulator. The loads are p-channel transistors connected between V_{DD} and the coil inputs. The layout includes metal mask options for the load circuit: single-side, double-side and alternate-side modulation.

Modulator

One of four methods of modulation can be selected by fuses. The timing diagram is shown in figure 5.

FSK

Logical "1" and "0" are distinguished via different frequencies of damping. The frequency for "1" is the RF divided by 10, a "0" divides by 8.

PSK

A logical “1” causes (at the end of the bit period) a 180° phase shift on the carrier frequency, while a logical “0” causes no phase shift. The carrier frequency is $RF/2$.

BIPH

Logical “1” produces a signal which is the same as the bit-clock and a logical “0” produces a signal of twice the bitclock period.

Manchester

A logical “1” causes a positive edge in the middle of a bit period, while a logical “0” causes negative edge.

A combination of BIPH- and FSK-modulation is also optionally available. The available combinations between the modulation types and the bitrates are shown in table “Transmission Options”.

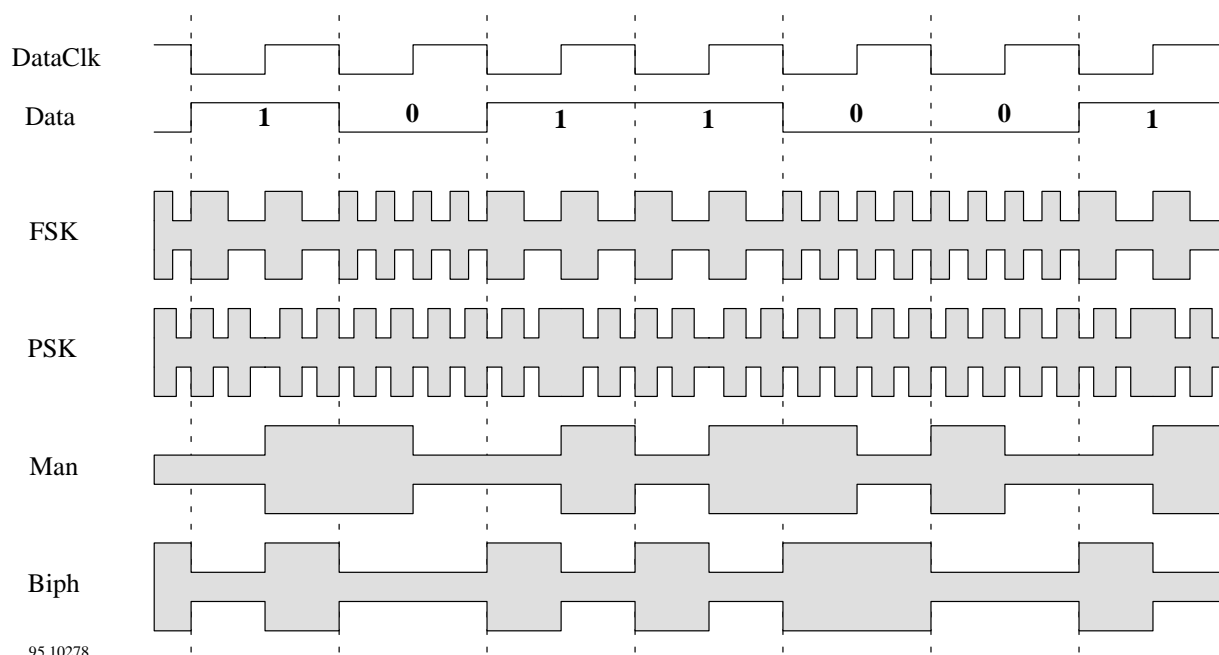

Figure 5. Timing diagram for modulation options

Absolute Maximum Ratings

Parameters	Symbol	Value	Unit
Maximum current into Coil1 and Coil2	I_{coil}	10	mA
Maximum power dissipation (dice)	P_{tot}	100	mW*
Maximum ambient air temperature with voltage applied	T_{amb}	-40 to +125	°C
Storage temperature	T_{stg}	-65 to +150	°C

* Free-air condition. Time of application: 1 s
Stresses above those listed under ‘Absolute Maximum Ratings’ may cause permanent damage to the device.
Functional operation of the device at these conditions is not implied.

Operating Characteristics

$T_{amb} = 25^{\circ}\text{C}$, reference terminal is V_{DD} , operating voltage $V_{DD} - V_{SS} = 3\text{ V}$ dc, unless otherwise specified

Parameters	Test Conditions / Pins	Symbol	Min.	Typ. *	Max.	Unit
Operating voltage	Condition for logic test	V_{SS}	-1.5		-5.0	V
Operating temperature		T_{amb}	-40		125	$^{\circ}\text{C}$
Input frequency (RF)		f_{CLK}	100		450	kHz
Operating current	$f_{CLK} = 125\text{ kHz}$, $V_{SS} = -2\text{ V}$	I_{CC}		3		μA
Clamp voltage	$I = 4\text{ mA}$	V_{CL}	6.7		10	V

* Typical parameters represent the statistical mean values

Transmission Options

Modulation	Carrier Frequency (CF)	Bitrate [bit/s]
FSK	RF/8, RF/10	RF/32, RF/40, RF/50, RF/64, RF/80, RF/100, RF/128
PSK	RF/2	CF/4, 8, 16, 32
BIPH		RF/8, RF/16, RF/32, RF/64, RF/100, RF/128
Manchester		RF/8, RF/16, RF/32, RF/64, RF/100, RF/128

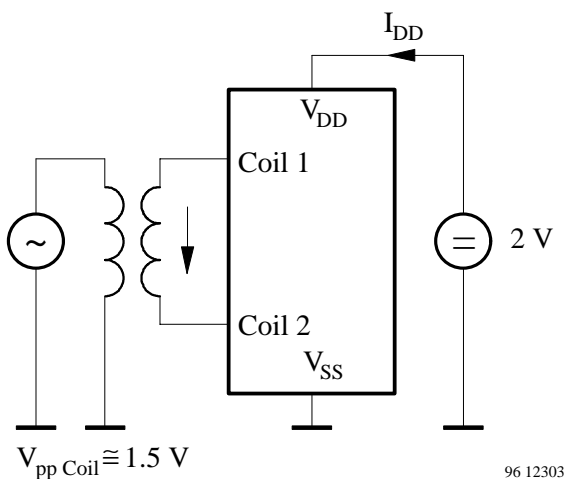

Figure 6. Measurement setup for I_{DD}

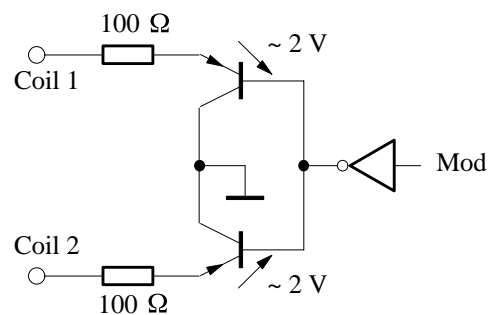
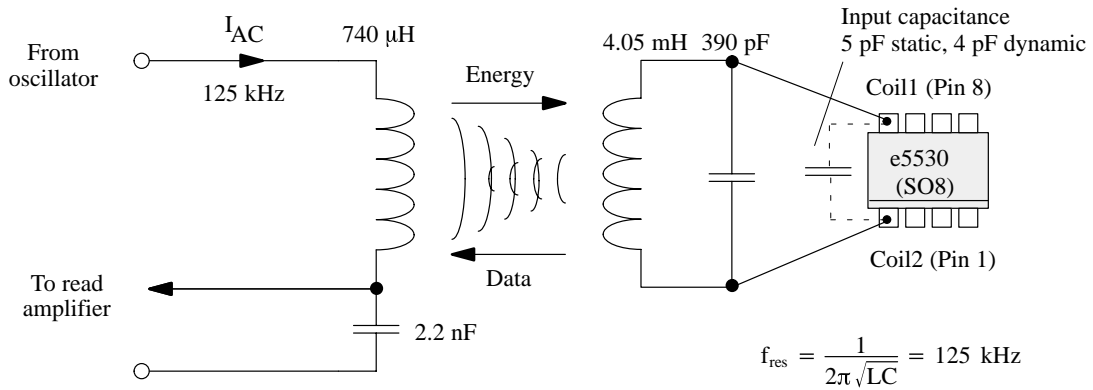

Figure 7. Simplified damping circuit

96 12304

Application Example



13369

Figure 8. Typical application circuit

Package Information

Package SO8

Dimensions in mm

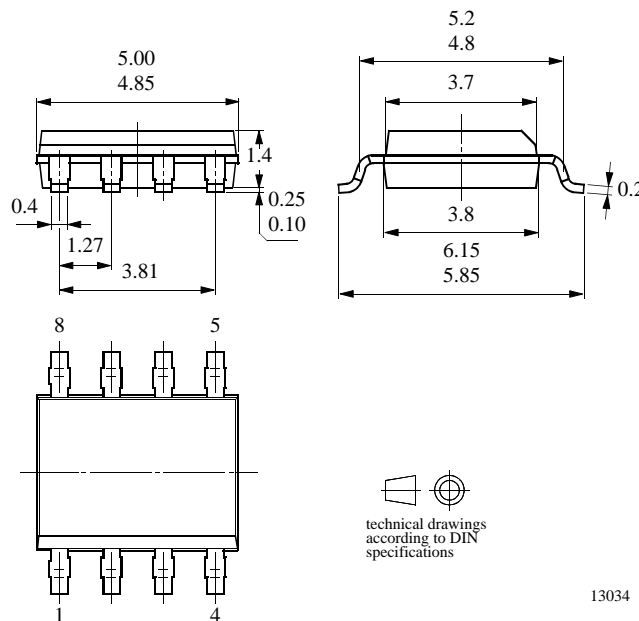

13034

We reserve the right to make changes to improve technical design and may do so without further notice.

Parameters can vary in different applications. All operating parameters must be validated for each customer application by the customer. Should the buyer use TEMIC products for any unintended or unauthorized application, the buyer shall indemnify TEMIC against all claims, costs, damages, and expenses, arising out of, directly or indirectly, any claim of personal damage, injury or death associated with such unintended or unauthorized use.

TEMIC Semiconductor GmbH, P.O.B. 3535, D-74025 Heilbronn, Germany
Telephone: 49 (0)7131 67 2594, Fax number: 49 (0)7131 67 2423