

DATA SHEET

NE56604-42

System reset with built-in Watchdog timer

Product data
Supersedes data of 2001 Aug 22

2003 Oct 15



System reset with built-in Watchdog timer

NE56604-42

GENERAL DESCRIPTION

The NE56604-42 is designed to generate a reset signal at a threshold voltage of 4.2 V for a variety of microprocessor and logic systems. Accurate reset signals are generated during momentary power interruptions, or whenever power supply voltages sag to intolerable levels. The NE56604-42 has a built-in Watchdog Timer to monitor the microprocessor and ensure it is operating properly. Any abnormal system operations due to microprocessor malfunctions are terminated by a system reset generated by the Watchdog. The NE56604-42 has a Watchdog monitoring time of 100 ms (typical).

The NE56604-42 is offered in the SO8 surface mount package (SOP005).

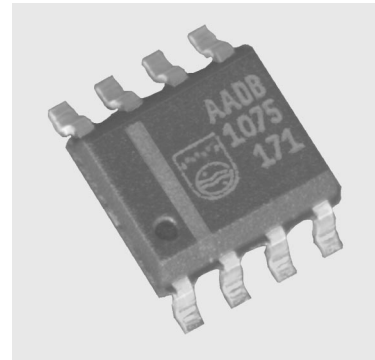

FEATURES

- Both positive and negative logic reset output signals are available
- Accurate threshold detection
- Internal power-on reset delay
- Internal Watchdog timer programmable with external resistor
- Watchdog monitoring time of 100 ms (typical)
- Reset assertion with V_{CC} down to 0.8 V_{DC} (typical)
- Few external components required.

APPLICATIONS

- Microcomputer systems
- Logic systems.

SIMPLIFIED SYSTEM DIAGRAM

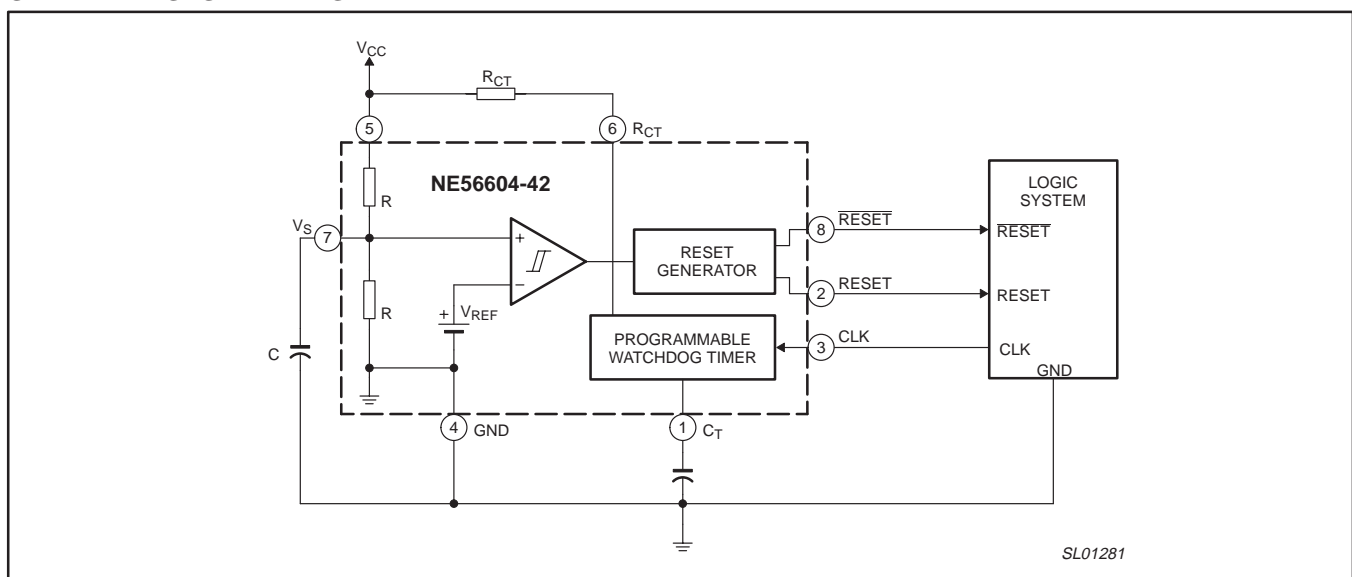

Figure 1. Simplified system diagram.

System reset with built-in Watchdog timer

NE56604-42

ORDERING INFORMATION

TYPE NUMBER	PACKAGE			TEMPERATURE RANGE
	NAME	DESCRIPTION	VERSION	
NE56604-42D	SO8	plastic small outline package; 8 leads; body width 3.9 mm	SOP005	-20 to +70 °C

Part number marking

The package is marked with a four letter code in the first line to the right of the logo. The first three letters designate the product. The fourth letter, represented by 'x', is a date tracking code. The remaining two or three lines of characters are internal manufacturing codes.

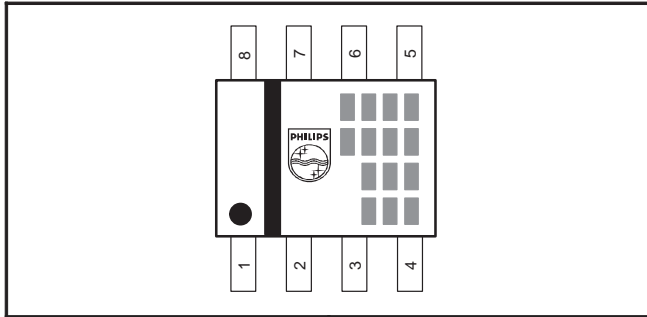

Part number	Marking
NE56604-42	A A D x

PIN CONFIGURATION

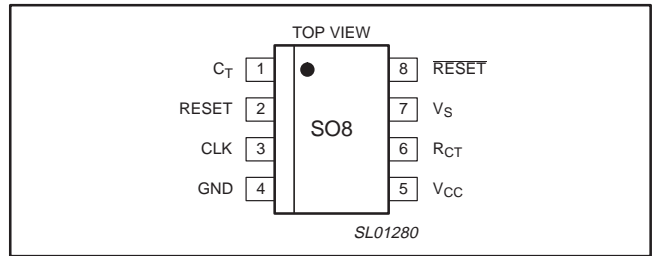

Figure 2. Pin configuration.

PIN DESCRIPTION

PIN	SYMBOL	DESCRIPTION
1	C_T	t_{WDM} , t_{WDR} , t_{PR} adjustment pin. t_{WDM} , t_{WDR} , t_{PR} times are dependent on the value of external C_T capacitor used. See Figure 20 (Timing Diagram) for definition of t_{WDM} , t_{WDR} , t_{PR} times.
2	RESET	Reset HIGH output pin.
3	CLK	Clock input pin from logic system for Watchdog timer.
4	GND	Circuit ground.
5	V_{CC}	Power supply pin for circuit.
6	R_{CT}	Watchdog timer control and program pin. Serves to ENABLE the Watchdog function when connected to pull-up resistor (R_{CT}) to V_{CC} , and DISABLE the Watchdog when connected to ground. Used in conjunction with C_T pin to program t_{WDM} time.
7	V_S	Detection threshold adjustment pin. The detection threshold can be increased by connecting this pin to V_{CC} with a pull-up resistor. The detection threshold can be decreased by connecting this pin to ground with a pull-down resistor.
8	\overline{RESET}	Reset LOW output pin.

System reset with built-in Watchdog timer

NE56604-42

MAXIMUM RATINGS

SYMBOL	PARAMETER	MIN.	MAX.	UNIT
V _{CC}	Power supply voltage	-0.3	10	V
V _{VS}	V _S pin voltage	-0.3	10	V
V _{CLK}	CLK pin voltage	-0.3	10	V
V _{OH}	RESET and RESET pin voltage	-0.3	10	V
T _{oper}	Operating temperature	-20	70	°C
T _{stg}	Storage temperature	-40	125	°C
P	Power dissipation	-	250	mW

DC ELECTRICAL CHARACTERISTICS

Characteristics measured with V_{CC} = 5.0 V, and T_{amb} = 25 °C, unless otherwise specified.
See Figure 26 (Test circuit 1) for test configuration used for DC parameters.

SYMBOL	PARAMETER	CONDITIONS	MIN.	TYP.	MAX.	UNIT
I _{CC}	Supply current during Watchdog timer operation		-	0.7	1.0	mA
V _{SL}	Reset detection threshold	V _S = open; V _{CC} = falling	4.05	4.20	4.35	V
V _{SH}		V _S = open; V _{CC} = rising	4.15	4.30	4.45	V
ΔV _S /ΔT _{amb}	Temperature coefficient of reset threshold	-20 °C ≤ T _{amb} ≤ 70 °C	-	±0.01	-	%/°C
V _{hys}	Threshold hysteresis	V _{hys} = V _{SH} (rising V _{CC}) - V _{SL} (falling V _{CC})	50	100	150	mV
V _{TH}	CLK input threshold		0.8	1.2	2.0	V
I _{IH}	CLK input current, HIGH-level	V _{CLK} = 5.0 V	-	0	1.0	μA
I _{IL}	CLK input current, LOW-level	V _{CLK} = 0 V	-20	-10	-3.0	μA
V _{OH1}	Output voltage, HIGH-level	I _{RESET} = -5.0 μA; V _S = open	4.5	4.8	-	V
V _{OH2}		I _{RESET} current = -5.0 mA; V _S = 0 V	4.5	4.8	-	V
V _{OL1}	Output voltage, LOW-level	I _{RESET} = 3.0 mA; V _S = 0 V	-	0.2	0.4	V
V _{OL2}		I _{RESET} = 10 mA; V _S = 0 V	-	0.3	0.5	V
V _{OL3}		I _{RESET} = 0.5 mA; V _S = open	-	0.2	0.4	V
V _{OL4}		I _{RESET} = 1.0 mA; V _S = open	-	0.3	0.5	V
I _{OL1}	Output sink current	V _{RESET} = 1.0 V; V _S = 0 V	10	16	-	mA
I _{OL2}		V _{RESET} = 1.0 V; V _S = open	1.0	2.0	-	mA
I _{CT1}	C _T charge current (Note 1)	V _{CT} = 1.0 V; R _{CT} = open during Watchdog operation	-0.8	-1.2	-2.4	μA
I _{CT2}		V _{CT} = 1.0 V; during power-on reset operation	-0.8	-1.2	-2.4	μA
V _{CCL1}	Supply voltage to assert reset operation	V _{RESET} = 0.4 V; I _{RESET} = 0.2 mA	-	0.8	1.0	V
V _{CCL2}		V _{RESET} = V _{CC} - 0.1 V; 1 MΩ resistor (pin 2 to GND)	-	0.8	1.0	V

NOTE:

- I_{CT} source current is determined by the value of the R_{CT} pull-up resistor to V_{CC}.

System reset with built-in Watchdog timer

NE56604-42

AC ELECTRICAL CHARACTERISTICSCharacteristics measured with $V_{CC} = 5.0\text{ V}$, and $T_{amb} = 25\text{ }^{\circ}\text{C}$, unless otherwise specified.

See Figure 27 (Test circuit 2) for test configuration used for AC parameters.

SYMBOL	PARAMETER	CONDITIONS	MIN.	TYP.	MAX.	UNIT
t_{P1}	Minimum power supply pulse width for detection	$4.0\text{ V} \leq \text{negative-going } V_{CC} \text{ pulse} \leq 5.0\text{ V}$	8.0	–	–	μs
t_{CLKW}	Clock input pulse width		3.0	–	–	μs
t_{CLK}	Clock input cycle		20	–	–	μs
t_{WDM}	Watchdog monitoring time (Notes 1, 6)	$C_T = 0.1\text{ }\mu\text{F}$; $R_{CT} = \text{open}$	50	100	150	ms
t_{WDR}	Watchdog reset time (Notes 2, 6)	$C_T = 0.1\text{ }\mu\text{F}$	1.0	2.0	3.0	ms
t_{PR}	Power-on reset delay time (Notes 3, 6)	$V_{CC} = \text{rising from } 0\text{ V}$; $C_T = 0.1\text{ }\mu\text{F}$	50	100	150	ms
t_{PD1}	Reset propagation delay time (Note 4)	RESET: $R_{L1} = 2.2\text{ k}\Omega$; $C_{L1} = 100\text{ pF}$	–	2.0	10	μs
t_{PD2}		RESET: $R_{L2} = 10\text{ k}\Omega$; $C_{L2} = 20\text{ pF}$	–	3.0	10	μs
t_{R1}	Reset rise time (Note 5)	RESET: $R_{L1} = 2.2\text{ k}\Omega$; $C_{L1} = 100\text{ pF}$	–	1.0	1.5	μs
t_{R2}		RESET: $R_{L2} = 10\text{ k}\Omega$; $C_{L2} = 20\text{ pF}$	–	1.0	1.5	μs
t_{F1}	Reset fall time (Note 5)	RESET: $R_{L1} = 2.2\text{ k}\Omega$; $C_{L1} = 100\text{ pF}$	–	0.1	0.5	μs
t_{F2}		RESET: $R_{L2} = 10\text{ k}\Omega$; $C_{L2} = 20\text{ pF}$	–	0.5	1.0	μs

NOTES:

- 'Watchdog monitoring time' is the duration from the last pulse (negative-going edge) of the timer clear clock pulse until reset output pulse occurs (see Figure 20). A reset signal is output if a clock pulse is not input during this time. Watchdog monitoring time can be modified by changing the value of the R_{CT} pull-up resistor. Monitoring time adjustments are shown in Figure 25.
- 'Watchdog reset time' is the reset pulse width (see Figure 20).
- 'Power-on reset delay time' is the duration measured from the time V_{CC} exceeds the upper detection threshold (V_{SH}) and power-on reset release is experienced (RESET output HIGH; RESET output LOW).
- 'Reset response time' is the duration from when the supply voltage sags below the lower detection threshold (V_{SL}) and reset occurs (RESET output LOW, RESET output HIGH).
- Reset rise and fall times are measured at 10% and 90% output levels.
- Watchdog monitoring time (t_{WDM}), Watchdog reset time (t_{WDR}), and power-on reset delay time (t_{PR}) during power-on can be modified by varying the C_T capacitance. The times can be approximated by applying the following formula. The recommended range for C_T is $0.001\text{ }\mu\text{F}$ to $10\text{ }\mu\text{F}$.

Formula 1. Calculation for approximate t_{PR} , t_{WDM} , and t_{WDR} values:

$$\begin{aligned} t_{PR} (\text{ms}) &\approx 1000 \times C_T (\mu\text{F}) \\ t_{WDM} (\text{ms}) &\approx 1000 \times C_T (\mu\text{F}) \\ t_{WDR} (\text{ms}) &\approx 20 \times C_T (\mu\text{F}) \end{aligned}$$

Example: When $C_T = 0.1\text{ }\mu\text{F}$ and $R_{CT} = \text{open}$:

$$\begin{aligned} t_{PR} &\approx 100\text{ ms} \\ t_{WDM} &\approx 100\text{ ms} \\ t_{WDR} &\approx 2.0\text{ ms} \end{aligned}$$

System reset with built-in Watchdog timer

NE56604-42

TYPICAL PERFORMANCE CURVES

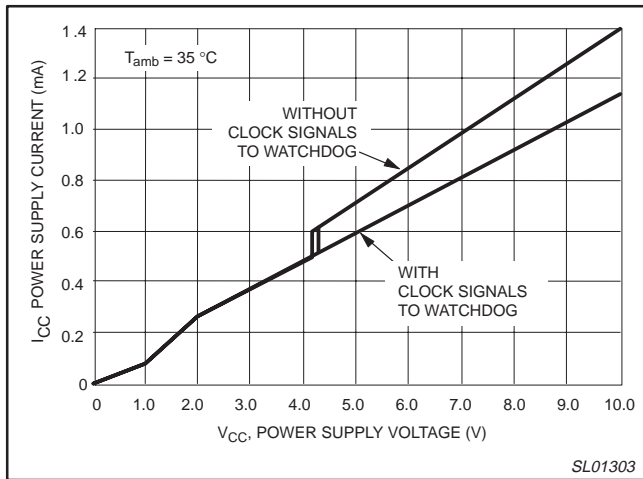

Figure 3. Power supply current vs. voltage.

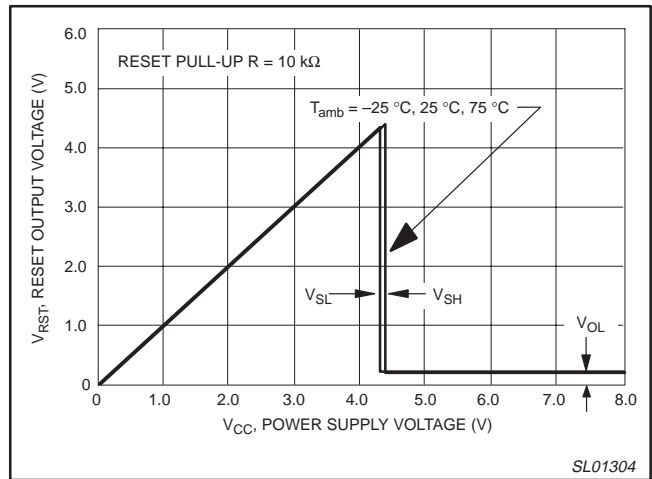

Figure 4. RESET output voltage vs. supply voltage.

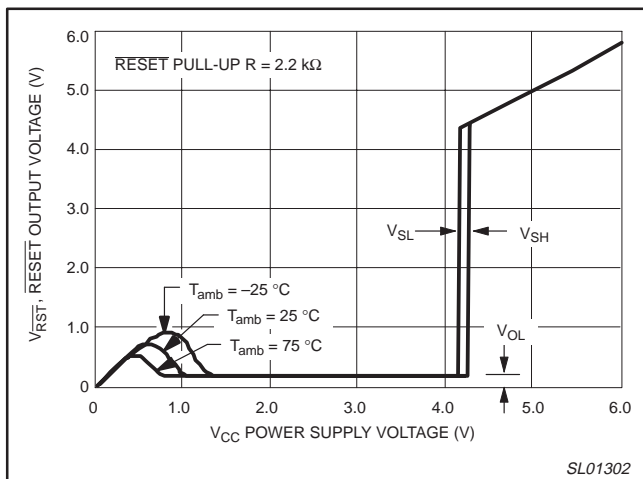

Figure 5. RESET output voltage vs. supply voltage.

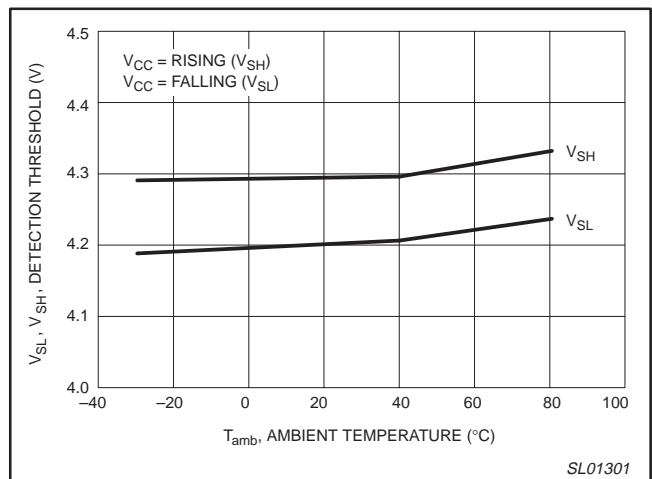

Figure 6. Detection threshold vs. temperature.

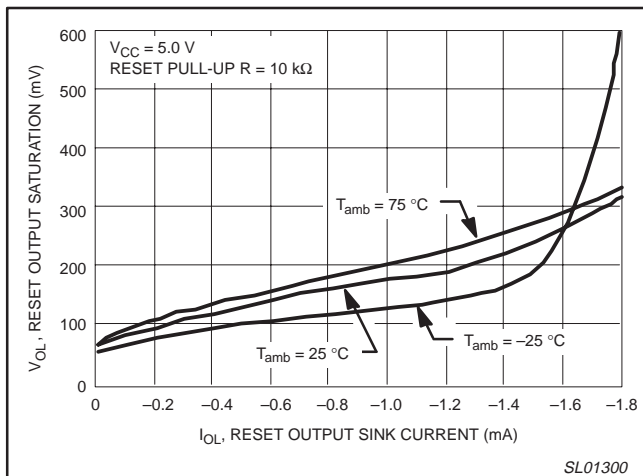

Figure 7. RESET saturation vs. sink current.

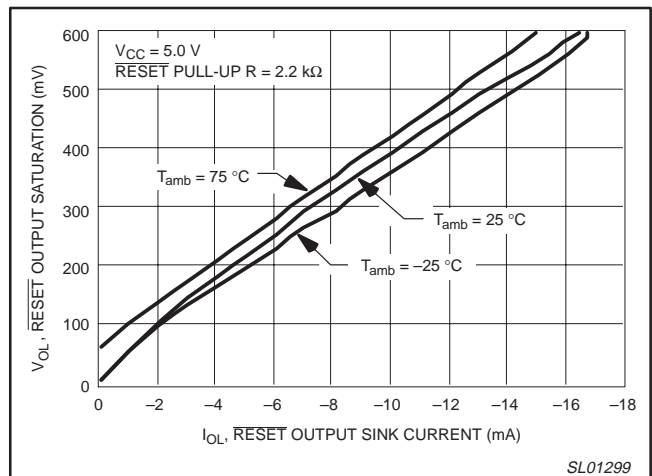

Figure 8. RESET saturation vs. sink current.

System reset with built-in Watchdog timer

NE56604-42

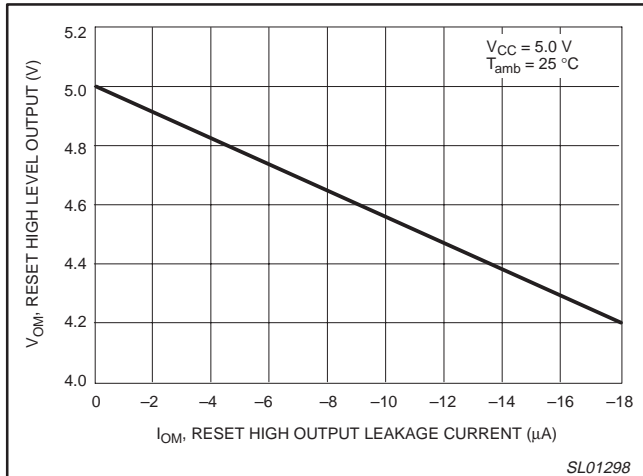

Figure 9. RESET HIGH-level voltage vs. current.

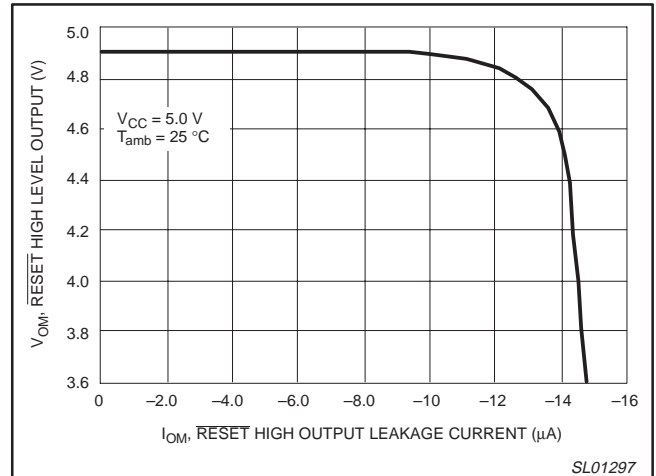

Figure 10. RESET HIGH-level voltage vs. current.

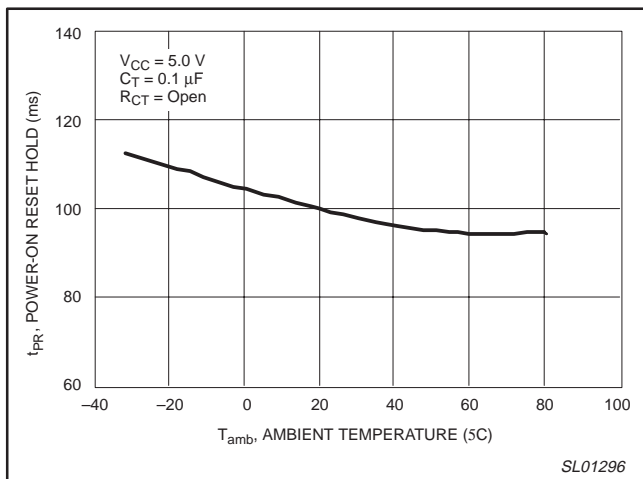

Figure 11. Power-on reset hold time vs. temperature.

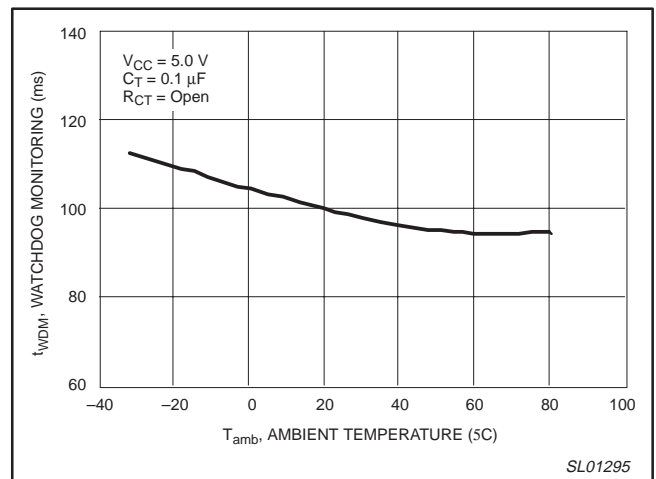

Figure 12. Watchdog monitoring time vs. temperature.

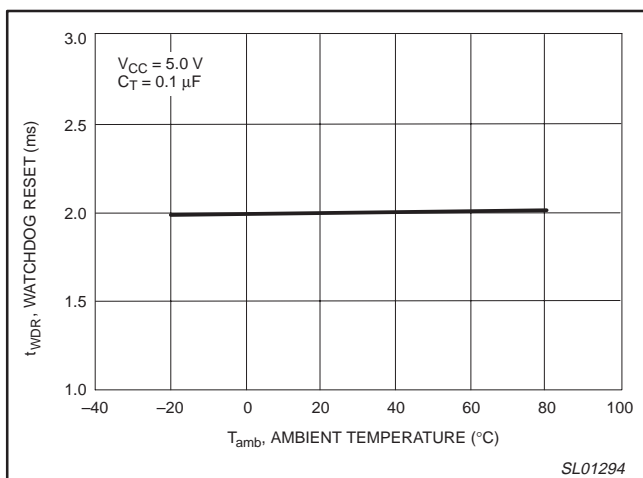

Figure 13. Watchdog reset time vs. temperature.

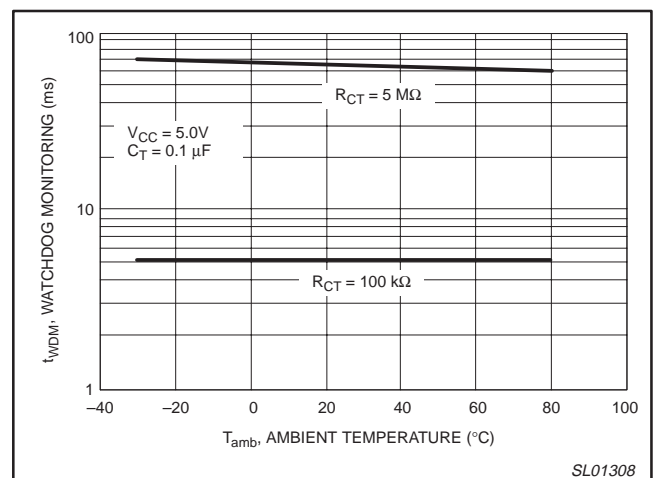

Figure 14. Watchdog monitoring time vs. temperature.

System reset with built-in Watchdog timer

NE56604-42

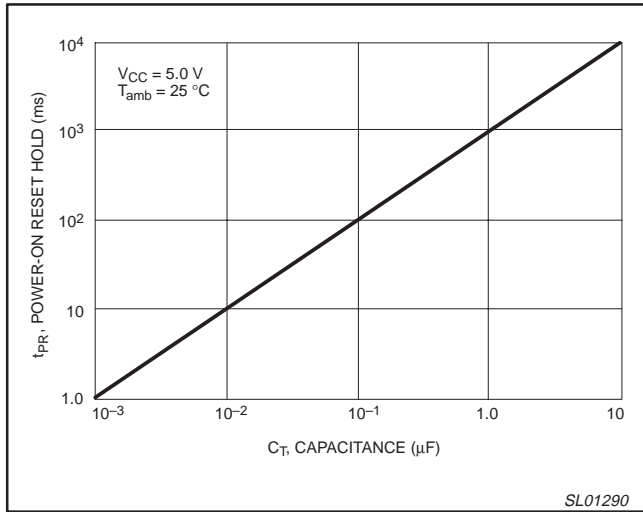

Figure 15. Power-on reset hold time vs. C_T .

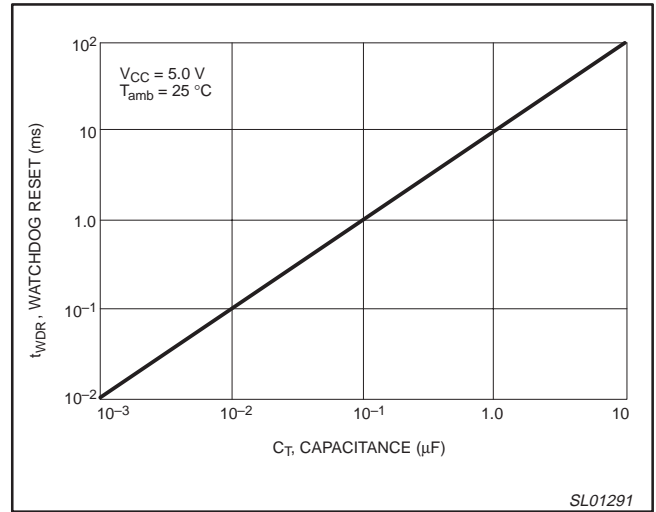

Figure 16. Watchdog reset time vs. C_T .

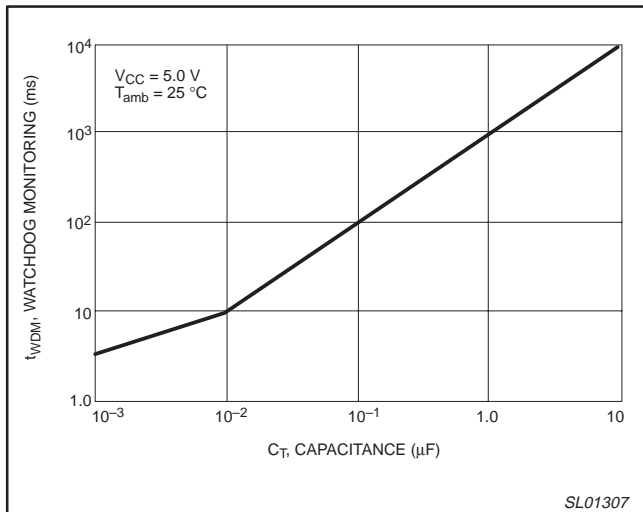

Figure 17. Watchdog reset time vs. C_T .

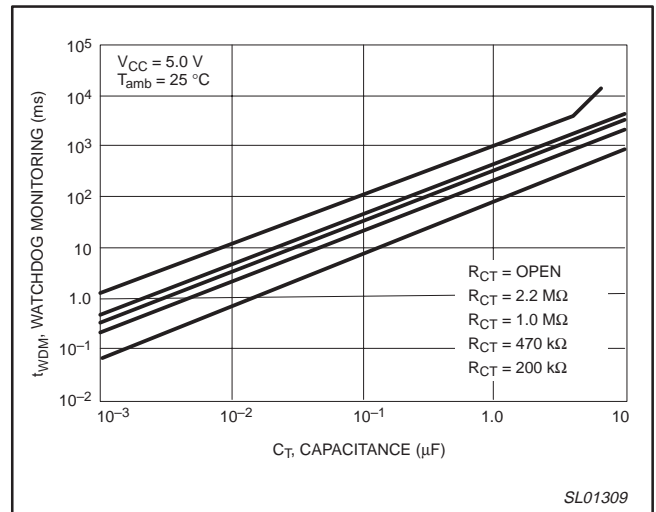

Figure 18. Watchdog monitoring time vs. C_T .

System reset with built-in Watchdog timer

NE56604-42

TECHNICAL DESCRIPTION

General discussion

The NE56604-42 combines a Watchdog timer and an undervoltage reset function in a single SO8 surface mount package. This provides a space-saving solution for maintaining proper operation of typical 5.0 volt microprocessor-based logic systems. Either function, or both, can force the microprocessor into a reset.

While the Watchdog monitors the microprocessor operation, the undervoltage reset monitors the supply voltage to the microprocessor. If the microprocessor clock signal ceases or becomes erratic, the NE56604-42 outputs a reset signal to the microprocessor. If the microprocessor supply voltage sags to 4.2 volts or less, the NE56604-42 outputs a reset signal for the duration of the supply voltage deficiency. The undervoltage reset signal allows the microprocessor to shut down in an orderly manner to avoid system corruption. In addition to a single reset output, the NE56604-42 has complementary $\overline{\text{RESET}}$ and RESET outputs for system use. The undervoltage detection threshold incorporates hysteresis to prevent generating erratic resets.

The Watchdog timer requires a pulse input. Normally this signal comes from the system microprocessor's clock. For operation, an external resistor (R_{CT}) must be connected from Pin 6 to V_{CC} and an external capacitor (C_T) from Pin 1 to ground. Normally a 0.1 μF capacitor is used for C_T . The external R_{CT} resistor and C_T capacitor establish the required minimum frequency of Watchdog input signal for the device to **not** output a reset signal. The R_{CT} resistor establishes, in part, the rate of charge of the C_T capacitor. In the absence of a Watchdog input pulse, the C_T capacitor charges to the 0.2 volt threshold of the internal comparator, causing a reset signal to be output. If microprocessor clock signals are received within the required interval, no Watchdog reset signal will be output. The Watchdog function can be disabled by grounding Pin 6 without affecting the undervoltage detection function.

Although the temperature coefficient of detection threshold is specified over a temperature of $-20\text{ }^\circ\text{C}$ to $+70\text{ }^\circ\text{C}$, the device will support operation in excess of this temperature range. See the supporting curves for performance over the full temperature range of $-40\text{ }^\circ\text{C}$ to $+85\text{ }^\circ\text{C}$. Some degradation in performance will be experienced at the temperature extremes and the system designer should take this into account.

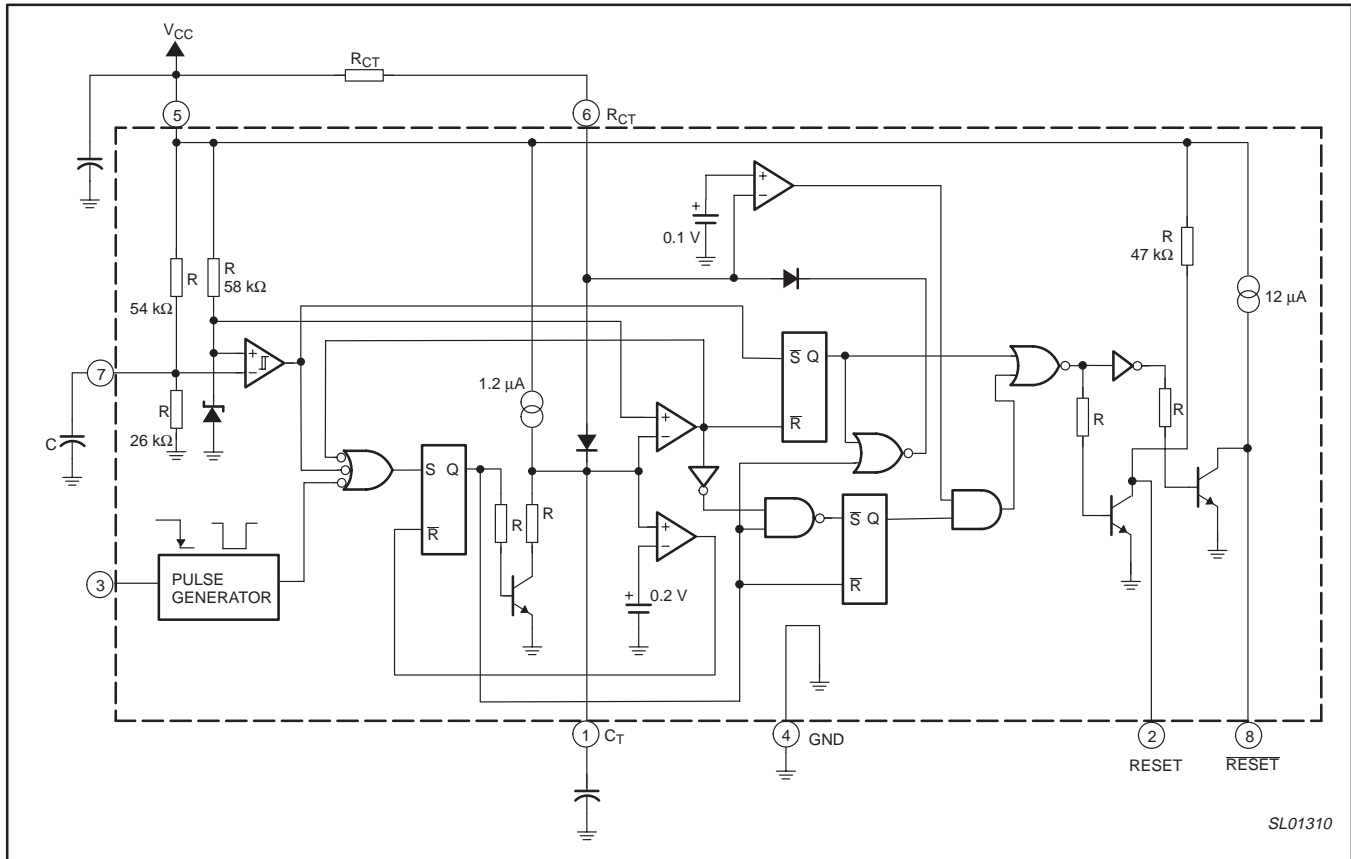

Figure 19. Functional diagram.

SL01310

System reset with built-in Watchdog timer

NE56604-42

Timing diagram

The timing diagram shown in Figure 20 depicts the operation of the device. Letters indicate events on the TIME axis.

A: At start-up 'A', the V_{CC} and RESET voltages begin to rise. Also the $\overline{\text{RESET}}$ voltage initially rises, but then abruptly returns to a LOW state. This is due to V_{CC} reaching the level ($\overline{\text{RESET}} 0.8 \text{ V}$) that activates the internal bias circuitry, asserting RESET.

B: Just before 'B', the C_T voltage starts to ramp up. This is caused by, and coincident to, V_{CC} reaching the threshold level of V_{SH} . At this level the device is in full operation. The RESET output continues to rise as V_{CC} rises above V_{SH} . This is normal.

C: At 'C', V_{CC} is above the undervoltage detect threshold, and C_T has ramped up to its upper detect level. At this point, the device removes the hold on the resets. $\overline{\text{RESET}}$ goes HIGH while RESET goes LOW. Also, an internal ramp discharge transistor activates, discharging C_T .

In a microprocessor-based system these events remove the reset from the microprocessor, allowing it to function normally. The system must send clock signals to the Watchdog Timer often enough to prevent C_T from ramping up to the C_T threshold, to prevent reset signals from being generated. Each clock signal discharges C_T .

C–D: Midway between 'C' and 'D', the CLK signals cease allowing the C_T voltage to ramp up to its RESET threshold at 'D'. At this time, reset signals are generated ($\overline{\text{RESET}}$ goes LOW; RESET goes HIGH). The device attempts to come out of reset as the C_T voltage is discharged and finally does come out of reset when CLK signals are re-established after two attempts of C_T .

E–F: Immediately before 'E', falling V_{CC} causes the $\overline{\text{RESET}}$ signal to sag. CLK signals are still being received, C_T is within normal operating range, and reset signals are not output. V_{CC} continues to sag until the V_{SL} undervoltage threshold is reached. At that time, reset signals are generated ($\overline{\text{RESET}}$ goes LOW; RESET goes HIGH).

At 'E', V_{CC} starts to rise, and the RESET voltage rises with V_{CC} . However, C_T voltage does not start to ramp up until 'F', when V_{CC} reaches the V_{SH} upper threshold.

G: The reset outputs are released at 'G' when C_T reaches the upper threshold level again. After 'G', normal CLK signals are received, but at a lower frequency than those following event 'C'. The frequency is above the minimum frequency required to keep the device from outputting reset signals.

G–H: At 'H', V_{CC} is normal, CLK signals are being received, and no reset signals are output. At event 'H', the V_{CC} starts falling, causing RESET to also fall.

J: At event 'J', V_{CC} sags to the point where the V_{SL} undervoltage threshold point is reached, and at that level reset signals are output ($\overline{\text{RESET}}$ to a LOW state, and RESET to a HIGH state). As the V_{CC} voltage falls lower, the RESET voltage falls lower.

K: At event 'K', the V_{CC} voltage has deteriorated to a level where normal internal circuit bias is no longer able to maintain a $\overline{\text{RESET}}$, and as a result may exhibit a slight rise to something less than 0.8 V . As V_{CC} decays even further, RESET also decreases to zero.

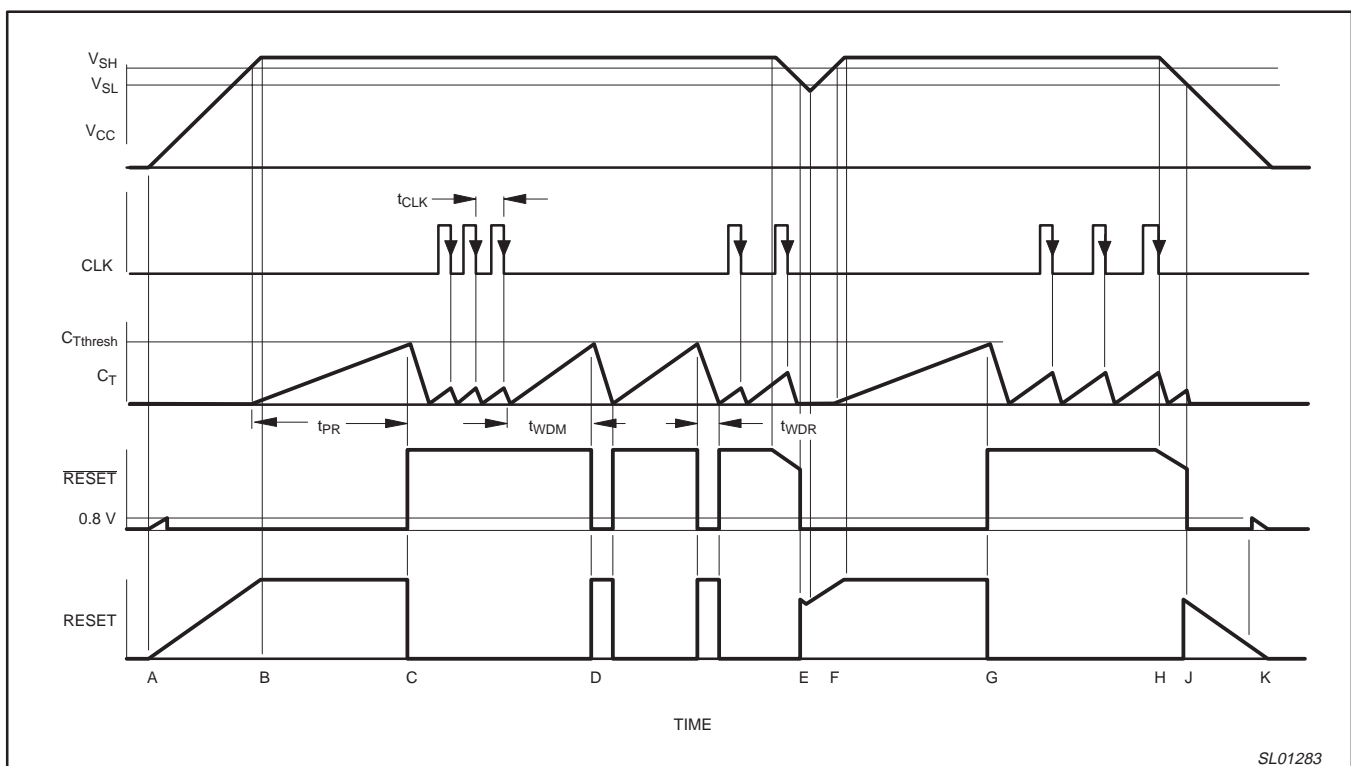

Figure 20. Timing diagram.

SL01283

System reset with built-in Watchdog timer

NE56604-42

Application information

The Watchdog timer's external component values are critical to its performance.

The detection threshold voltage can be adjusted by externally influencing the internal divider reference voltage. Figures 21 and 23 show a method to lower and raise the threshold voltage. Figures 22 and 24 show the influence of the pull-down and pull-up resistors on the threshold voltage. The use of a capacitor (1000 pF or larger) from Pin 7 to ground is recommended to filter out noise from being imposed on the threshold voltages.

The Reset Detection Threshold can be decreased by connecting an external resistor R_1 from Pin 7 to V_{CC} , as shown in Figure 21. See Figure 22 to determine the approximate value of R_1 to use.

The Reset Detection Threshold can be increased by connecting an external resistor R_2 from Pin 7 to ground, as shown in Figure 23. See Figure 24 to determine the approximate value of R_2 to use.

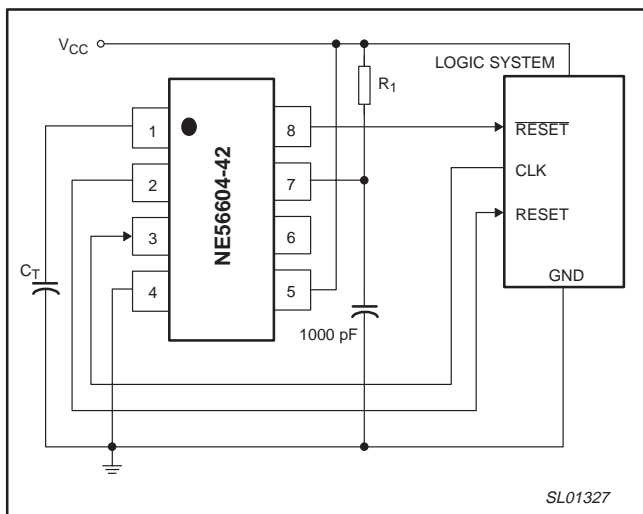

Figure 21. Circuit to lower detection threshold.

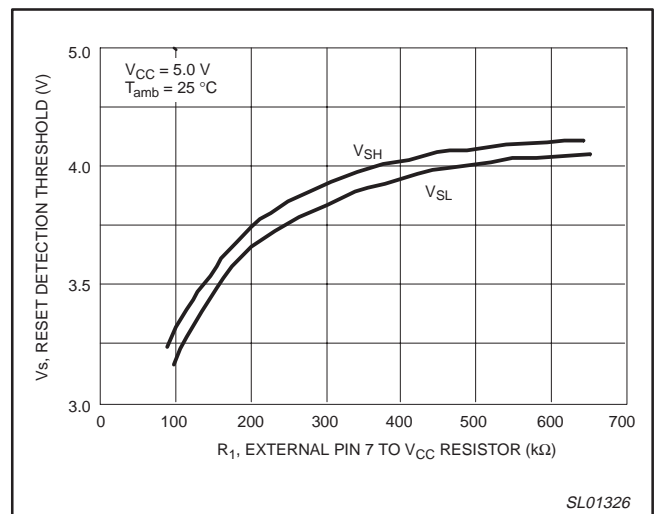

Figure 22. Reset detection threshold vs. external R_1 .

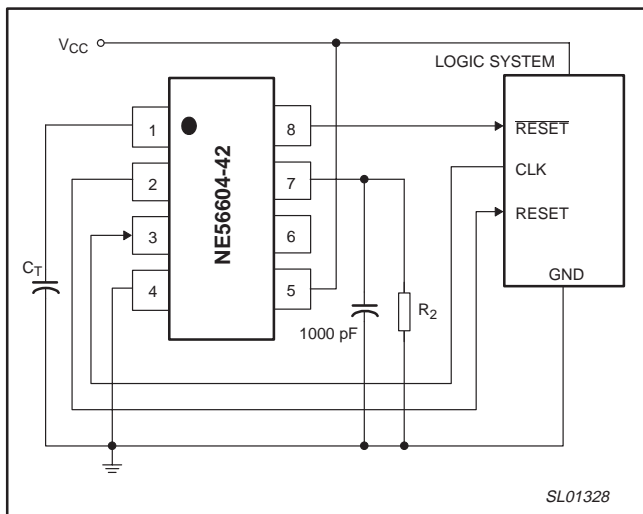

Figure 23. Circuit to raise detection threshold.

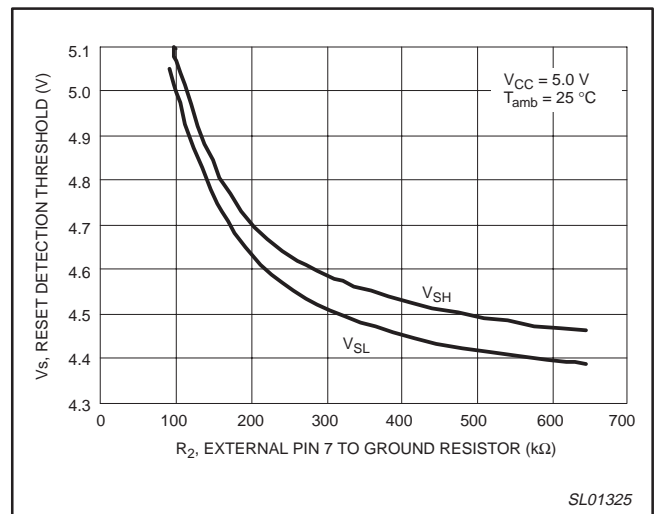

Figure 24. Reset detection threshold vs. external R_2 .

System reset with built-in Watchdog timer

NE56604-42

The values of R_{CT} and C_T affect the Watchdog monitoring time (t_{WDM}), the Watchdog reset time (t_{WDR}), and power-on reset delay time (t_{PR}). See Formula 1 in the AC Electrical Characteristics and the Timing diagram shown in Figure 20 for parameter definitions. Also see Figures 11 through 18 for typical time relationship performance.

The effect of R_{CT} on the Watchdog timer monitoring time at room temperature for $C_T = 0.1 \text{ mF}$ is shown in Figure 25.

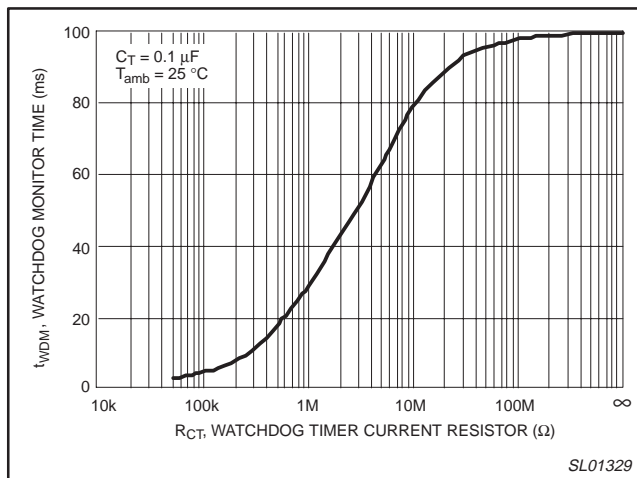

Figure 25. Watchdog monitoring vs. pull-up resistor R_{CT} .

System reset with built-in Watchdog timer

NE56604-42

Parametric testing

DC and AC Characteristics can be tested using the circuits shown in Figures 26 and 27. Associated switch and power supply settings are shown in Table 1 and Table 2, respectively.

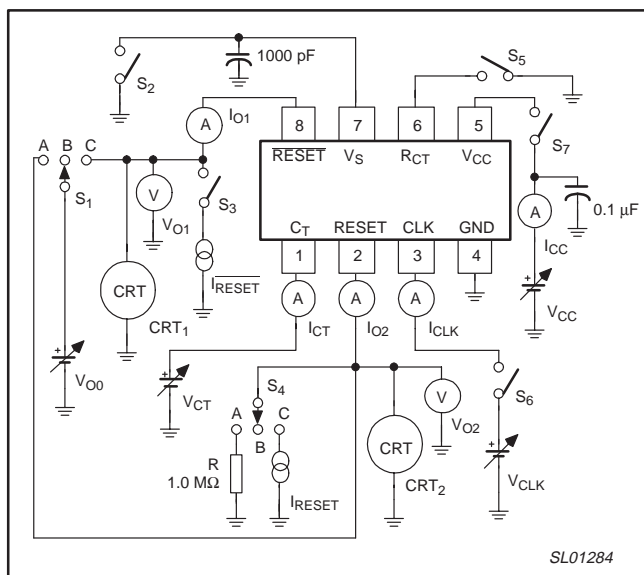

Figure 26. Test Circuit 1 (DC parameters).

Table 1. DC characteristics Test Circuit 1 switch and power supply settings

Parameter	Symbol	S ₁	S ₂	S ₃	S ₄	S ₅	S ₆	S ₇	V _{CC}	V _{CLK}	V _{CT}	$\overline{I_{RESET}}$	I _{RESET}	Read
Power supply current	I _{CC}	B	OFF	OFF	B	OFF	ON	ON	5.0 V	5.0 V	0 V	-	-	I _{CC}
Reset threshold (LOW) (Note 1)	V _{SL}	B	OFF	OFF	B	ON	ON	ON	5.0 to 4.0 V	3.0 V	3.0 V	-	-	V _{O1} , CRT ₁
Reset threshold (HIGH) (Note 2)	V _{SH}	B	OFF	OFF	B	ON	ON	ON	4.0 to 5.0 V	3.0 V	3.0 V	-	-	V _{O1} , CRT ₁
Clock input threshold (Note 3)	V _{TH}	B	OFF	OFF	B	OFF	ON	ON	5.0 V	0 to 3.0 V	1.0 V	-	-	I _{CLK}
Clock input current (HIGH)	I _{TH}	B	OFF	OFF	B	OFF	ON	ON	5.0 V	5.0 V	0 V	-	-	I _{CLK}
Clock input current (LOW)	I _{TL}	B	OFF	OFF	B	OFF	ON	ON	5.0 V	0 V	0 V	-	-	I _{CLK}
Reset output voltage (HIGH)	V _{OH1}	B	OFF	ON	B	ON	ON	ON	5.0 V	5.0 V	3.0 V	-5.0 μA	-	V _{O1}
	V _{OH2}	B	ON	OFF	C	ON	ON	ON	5.0 V	5.0 V	3.0 V	-	-5.0 μA	V _{O2}
Reset output voltage (LOW)	V _{OL1}	B	ON	ON	B	ON	ON	ON	5.0 V	5.0 V	3.0 V	3.0 mA	-	V _{O1}
	V _{OL2}	B	ON	ON	B	ON	ON	ON	5.0 V	5.0 V	3.0 V	10 mA	-	V _{O1}
	V _{OL3}	B	OFF	OFF	C	ON	ON	ON	5.0 V	5.0 V	3.0 V	-	0.5 mA	V _{O2}
	V _{OL4}	B	OFF	OFF	C	ON	ON	ON	5.0 V	5.0 V	3.0 V	-	1 mA	V _{O2}
Reset output sink current (Note 4)	I _{OL1}	C	ON	OFF	B	ON	ON	ON	5.0 V	5.0 V	3.0 V	-	-	I _{O1}
	I _{OL2}	A	OFF	OFF	B	ON	ON	ON	5.0 V	5.0 V	3.0 V	-	-	I _{O2}
C _T charge current 1	I _{CT1}	B	OFF	OFF	B	OFF	OFF	ON	5.0 V	-	1.0 V	-	-	I _{CT}
C _T charge current 2	I _{CT2}	B	OFF	OFF	B	ON	OFF	ON	5.0 V	-	1.0 V	-	-	I _{CT}
Minimum power supply for RESET (Note 5)	V _{CCL1}	B	OFF	ON	B	ON	ON	ON	0 to 2.0 V	0 V	0 V	-	-	V _{O1} , V _{CC}
Minimum power supply for RESET (Note 6)	V _{CCL2}	B	ON	OFF	A	ON	ON	ON	0 to 2.0 V	0 V	0 V	-	-	V _{O2} , V _{CC}

NOTES:

1. Decrease V_{CC} from 5.0 V to 4.0 V and note the V_{CC} value when V_{O1} (observed on CRT₁) transitions to an abrupt LOW state.
2. Increase V_{CC} from 4.0 V to 5.0 V and note the V_{CC} value when V_{O1} (observed on CRT₁) transitions to an abrupt HIGH state.
3. Increase the Clock voltage (V_{CLK}) from 0 V to 3.0 V and observe the value of V_{CLK} when I_{CLK} transitions to an abrupt increase.
4. Measured with V_{O0} = 1.0 V.
5. Increase V_{CC} from 0 V to 2.0 V and note the V_{CC} value when V_{O1} (observed on CRT₁) transitions to an abrupt LOW state. The V_{O1} value will initially track the V_{CC} voltage increase until the internal circuit bias becomes active, at which time the V_{O1} value will return to a LOW state.
6. Increase V_{CC} from 0 V to 2.0 V and note the V_{CC} value when V_{O2} (observed on CRT₂) starts to track the V_{CC} voltage.

System reset with built-in Watchdog timer

NE56604-42

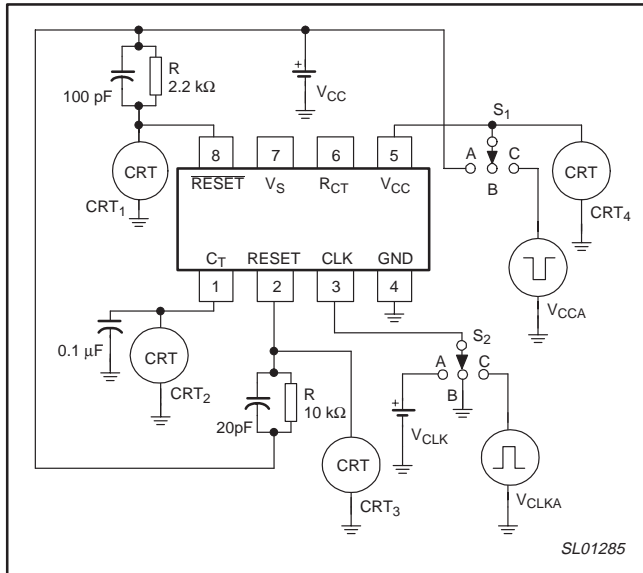

Figure 27. Test Circuit 2 (AC parameters).

Table 2. Switch and power supply settings, AC parameters

Parameter	Symbol	S ₁	S ₂	V _{C_{CA}}	V _{C_C}	V _{C_{L_{KA}}}	V _{C_{L_K}}	CRT
V _{C_C} pulse width for detection (Note 1)	t _{p1}	C	C	5.0 V 4.0 V	—	1.4 V 0 V	—	1, 2, 3
Clock input pulse width (Note 2)	t _{CLKW}	A	C	—	5.0 V	1.4 V 0 V	—	1, 2, 3
Clock input cycle (Note 3)	t _{CLK}	A	C	—	5.0 V	1.4 V 0 V	—	1, 2, 3
Watchdog monitoring time	t _{WDM}	A	A	—	5.0 V	—	5.0 V	1, 2, 3
Watchdog reset time	t _{WDR}	A	A	—	5.0 V	—	5.0 V	1, 2, 3
Power-on reset delay time	t _{PR}	B to A	A	—	5.0 V	—	5.0 V	1, 2, 3
RESET, $\overline{\text{RESET}}$ propagation delay time	t _{PD1}	C	B	5.0 V 4.0 V	—	—	0 V	1, 2
	t _{PD2}	C	B	5.0 V 4.0 V	—	—	0 V	2, 3
RESET, $\overline{\text{RESET}}$ rise time	t _{R1}	A	A	—	5.0 V	—	5.0 V	1
	t _{R2}	A	A	—	5.0 V	—	5.0 V	3
RESET, $\overline{\text{RESET}}$ fall time	t _{F1}	A	A	—	5.0 V	—	5.0 V	1
	t _{F2}	A	A	—	5.0 V	—	5.0 V	3

NOTES:

1. t₁ = 8.0 μs.
2. t₂ = 3.0 μs.
3. t₃ = 20 μs.

System reset with built-in Watchdog timer

NE56604-42

PACKING METHOD

The NE56604-42 is packed in reels, as shown in Figure 28.

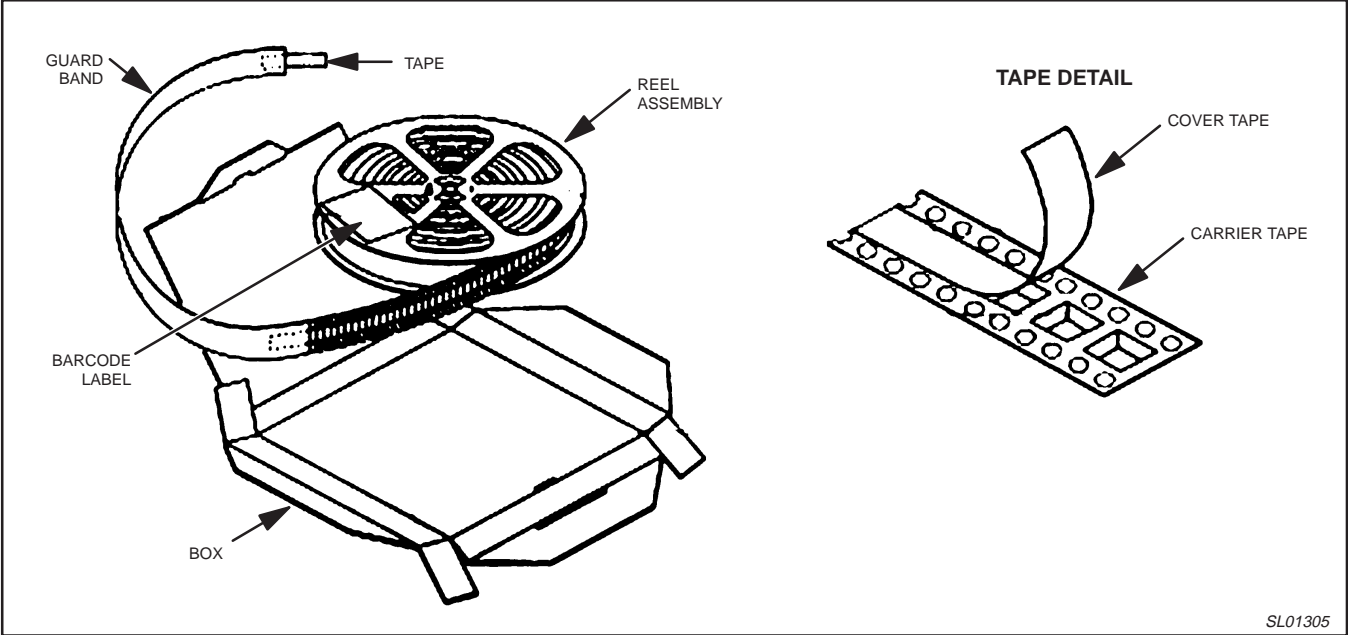

SL01305

Figure 28. Tape and reel packing method

System reset with built-in Watchdog timer

NE56604-42

SO8: plastic small outline package; 8 leads; body width 3.9 mm

SOP005

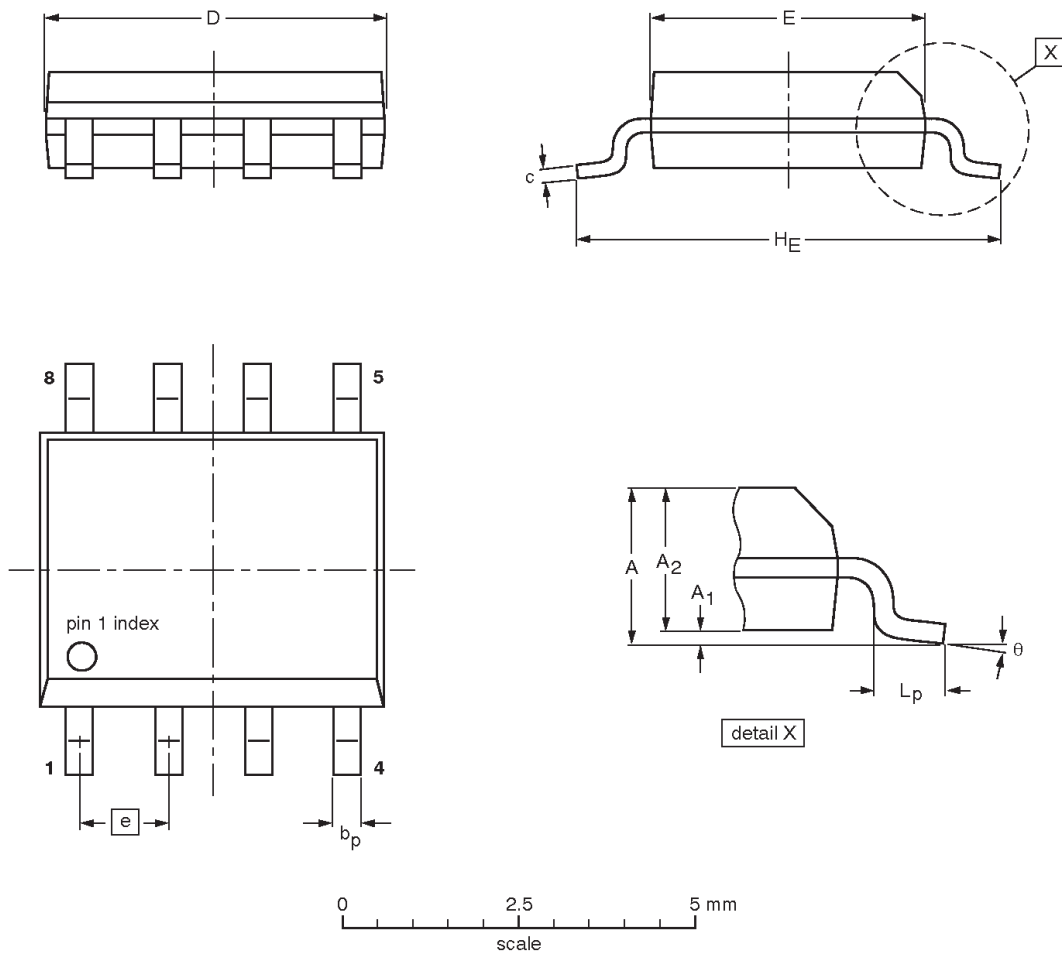

DIMENSIONS (inch dimensions are derived from the original mm dimensions)

UNIT	A max.	A ₁	A ₂	b _p	c	D ⁽¹⁾	E ⁽²⁾	e	H _E	L _p	θ
mm	1.73	0.25 0.10	1.45 1.25	0.51 0.33	0.25 0.19	4.95 4.80	4.0 3.8	1.27	6.2 5.8	1.27 0.38	8° 0°
inches	0.068	0.010 0.004	0.057 0.049	0.013 0.020	0.0100 0.0075	0.20 0.19	0.16 0.15	0.050	0.244 0.228	0.050 0.015	

Notes

1. Plastic or metal protrusions of 0.15 mm maximum per side are not included.
2. Plastic or metal protrusions of 0.25 mm maximum per side are not included.

OUTLINE VERSION	REFERENCES			EUROPEAN PROJECTION	ISSUE DATE
	IEC	JEDEC	JEITA		
SOP005	076E03	MS-012			03-10-07

System reset with built-in Watchdog timer

NE56604-42

REVISION HISTORY

Rev	Date	Description
_4	20031015	Product data (9397 750 12115). ECN 853-2250 30313 of 08 September 2003. Super sedes data of 2001 Aug 22 (9397 750 08732). Modifications: <ul style="list-style-type: none"> • Change package version to SOP005 in Ordering information and Package outline sections.
_3	20010822	Product data (9397 750 08732). ECN 853-2250 26949 of 22 August 2001. Supersedes data of 2001 Jun 19.

Data sheet status

Level	Data sheet status [1]	Product status [2] [3]	Definitions
I	Objective data	Development	This data sheet contains data from the objective specification for product development. Philips Semiconductors reserves the right to change the specification in any manner without notice.
II	Preliminary data	Qualification	This data sheet contains data from the preliminary specification. Supplementary data will be published at a later date. Philips Semiconductors reserves the right to change the specification without notice, in order to improve the design and supply the best possible product.
III	Product data	Production	This data sheet contains data from the product specification. Philips Semiconductors reserves the right to make changes at any time in order to improve the design, manufacturing and supply. Relevant changes will be communicated via a Customer Product/Process Change Notification (CPCN).

[1] Please consult the most recently issued data sheet before initiating or completing a design.

[2] The product status of the device(s) described in this data sheet may have changed since this data sheet was published. The latest information is available on the Internet at URL <http://www.semiconductors.philips.com>.

[3] For data sheets describing multiple type numbers, the highest-level product status determines the data sheet status.

Definitions

Short-form specification — The data in a short-form specification is extracted from a full data sheet with the same type number and title. For detailed information see the relevant data sheet or data handbook.

Limiting values definition — Limiting values given are in accordance with the Absolute Maximum Rating System (IEC 60134). Stress above one or more of the limiting values may cause permanent damage to the device. These are stress ratings only and operation of the device at these or at any other conditions above those given in the Characteristics sections of the specification is not implied. Exposure to limiting values for extended periods may affect device reliability.

Application information — Applications that are described herein for any of these products are for illustrative purposes only. Philips Semiconductors make no representation or warranty that such applications will be suitable for the specified use without further testing or modification.

Disclaimers

Life support — These products are not designed for use in life support appliances, devices, or systems where malfunction of these products can reasonably be expected to result in personal injury. Philips Semiconductors customers using or selling these products for use in such applications do so at their own risk and agree to fully indemnify Philips Semiconductors for any damages resulting from such application.

Right to make changes — Philips Semiconductors reserves the right to make changes in the products—including circuits, standard cells, and/or software—described or contained herein in order to improve design and/or performance. When the product is in full production (status 'Production'), relevant changes will be communicated via a Customer Product/Process Change Notification (CPCN). Philips Semiconductors assumes no responsibility or liability for the use of any of these products, conveys no license or title under any patent, copyright, or mask work right to these products, and makes no representations or warranties that these products are free from patent, copyright, or mask work right infringement, unless otherwise specified.

Contact information

For additional information please visit
<http://www.semiconductors.philips.com>. Fax: +31 40 27 24825

© Koninklijke Philips Electronics N.V. 2003
 All rights reserved. Printed in U.S.A.

For sales offices addresses send e-mail to:
sales.addresses@www.semiconductors.philips.com

Date of release: 10-03
 Document order number: 9397 750 12115

Let's make things better.