

# DATA SHEET

## NE57810

Advanced DDR memory termination power  
with external reference in

Product data

Supersedes data of 2002 Jul 16

2003 Sep 12



# Advanced DDR memory termination power with external reference in

## NE57810

### DESCRIPTION

The NE57810 is designed to provide power for termination of a Double Data Rate (DDR) SDRAM memory bus. It significantly reduces parts count, board space, and overall system cost compared to previous solutions.

The NE57810 DDR termination regulator maintains an output voltage (DDR reference bus voltage) that is one-half that of the RAM supply voltage. It is capable of providing up to  $\pm 3.5$  A for sustained periods. Overcurrent limiting protects the NE57810 from inrush currents at start-up, and overtemperature shutdown protects the device in extreme temperature situations.

The SPAK-5 (SOT756) package is thermally robust for flexibility of thermal design. Because the NE57810 is a linear regulator, no external inductors or switching FETs are necessary. Fast response to load changes reduces the need for output capacitors.



### FEATURES

- Fast transient response time
- Overtemperature protection
- Overcurrent protection
- Commercial (0 °C to +70 °C) temperature range
- Reduced need for external components (switching FETs, inductors, decoupling capacitors)
- Internal divider maintains termination voltage at  $1/2$  memory supply voltage
- Reference out for other memory and control components
- Optional external voltage reference in for flexible application
- Compatible with DDR-I ( $V_{DD} = 2.5$  V) or DDR-II ( $V_{DD} = 1.8$  V) SDRAM systems

### APPLICATIONS

- Desktop microcomputer systems
- Workstations
- Servers
- Game machines
- Set top boxes
- Embedded systems
- Digital video recorders

### SIMPLIFIED SYSTEM DIAGRAM

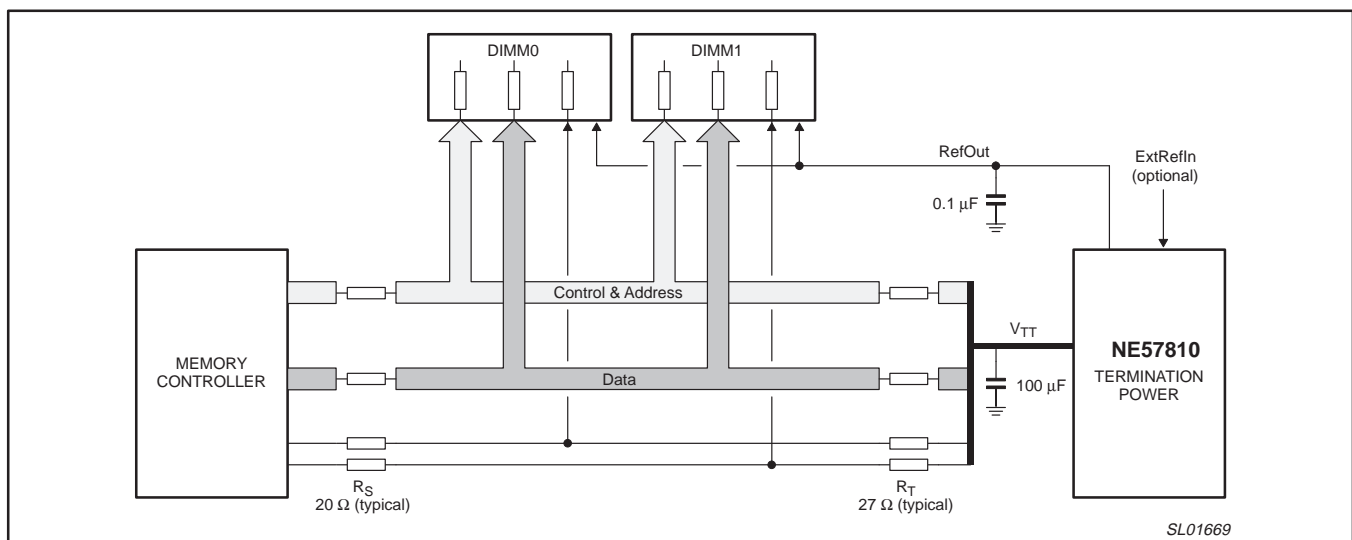

Figure 1. Simplified system diagram.

# Advanced DDR memory termination power with external reference in

NE57810

## ORDERING INFORMATION

TYPE NUMBER	PACKAGE			TEMPERATURE RANGE
	NAME	DESCRIPTION	VERSION	
NE57810S	SPAK-5	plastic single-ended surface mounted package; 5 leads	SOT756	0 °C to +70 °C

## Part number marking

The package is marked with the part number. The remaining characters are manufacturing codes.

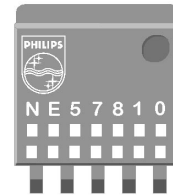

## PIN CONFIGURATION

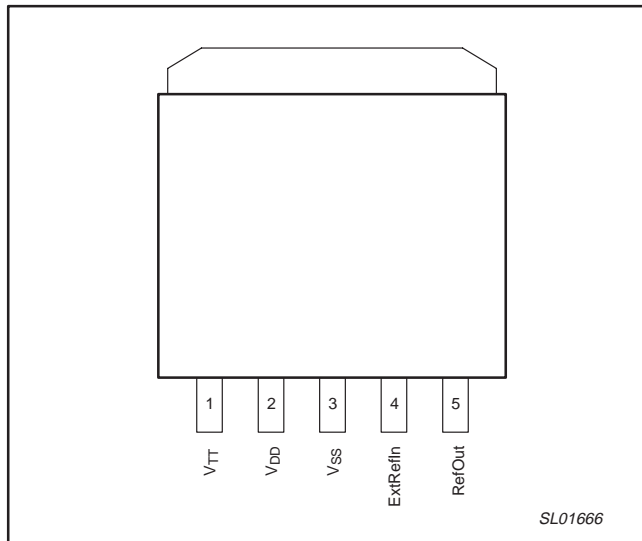

Figure 2. Pin configuration.

## PIN DESCRIPTION

PIN	SYMBOL	DESCRIPTION
1	$V_{TT}$	Regulated terminator voltage
2	$V_{DD}$	Power supply
3	$V_{SS}$	Circuit ground (Note 1)
4	ExtRefIn	External reference voltage in
5	RefOut	Reference voltage out

### NOTE:

- The thermal backside pad connects electrically to  $V_{SS}$  internally and provides enhancement to thermal conductivity, but it should not be used as the primary connection to ground. Device specifications apply to use of the  $V_{SS}$  pin as the connection to ground.

## MAXIMUM RATINGS

SYMBOL	PARAMETER	MIN.	TYP.	MAX.	UNIT
$V_{DD}$	$V_{DD}$ to $V_{SS}$ voltage	-0.3	-	+3.6	V
$T_{amb}$	Operating ambient temperature	0	-	+70	°C
$T_{stg}$	Storage temperature	-40	-	+165	°C
$T_j$	Junction temperature	-	-	160	°C
$R_{th(j-a)}$	Thermal resistance, junction to ambient	-	16.5	-	°C/W
$P_D$	Power dissipation (Note 1)	-	-	3.3	W

### NOTE:

- Tested on a minimum footprint on a four-layer PCB per JEDEC specification JESD51-7.

# Advanced DDR memory termination power with external reference in

NE57810

## ELECTRICAL CHARACTERISTICS

$T_{amb} = 0\text{ }^{\circ}\text{C}$  to  $+75\text{ }^{\circ}\text{C}$ ,  $V_{DD} = 2.5\text{ V}$ ;  $I_{TT} = -3.5\text{ A}$  to  $+3.5\text{ A}$ , unless otherwise specified.

SYMBOL	PARAMETER	CONDITIONS	MIN.	TYP.	MAX.	UNIT
$V_{TT}$	Output voltage	ExtRefIn not connected	–	$V_{DD}/2$	–	V
$V_{ACC}$	Output voltage accuracy (Note 5)	$I_{TT} = 0\text{ A}$ , ExtRefIn not connected	–15	–	+15	mV
$V_{DD}$	Supply voltage		1.6	–	3.6	V
$I_Q$	Supply current	$I_{TT} = 0\text{ A}$	–	14	30	mA
$I_{TT}$	Output current	$2.5\text{ V} \leq V_{DD} \leq 3.6\text{ V}$	–3.5	–	+3.5	A
		$V_{DD} = 1.6\text{ V}$	–2.5	–	+2.5	A
$\Delta V_{TT}$	Load regulation	$I_{TT} = \pm 1.0\text{ A}$	–	$\pm 6$	–	mV
		$I_{TT} = \pm 3.5\text{ A}$	–18	–	+18	mV
$C_{LOAD}$	Load capacitance (Note 2)	Stable operation	–	100	–	$\mu\text{F}$
<b>External Reference In</b>						
$V_{TT}$	Output voltage swing		0.8	–	$V_{DD} - 0.8$	V
$R_{in(ExtRefIn)}$	Input impedance		35	50	–	$\text{k}\Omega$
	Output voltage accuracy (Note 3)	$I_{TT} = 0\text{ A}$	–15	–	+15	mV
	Line regulation	ExtRefIn = 1.25 V; $V_{DD} = 2.25 - 3.6\text{ V}$	–6	–	+6	mV
<b>Reference Out</b>						
RefOut	Voltage reference out (Note 4)	$I_{refOut} = 0\text{ A}$ ; source or sink	–15	ExtRefIn	+15	mV
$I_{refOut}$	Reference Out current max		2.2	3	–	mA
$C_{LOAD}$	Load capacitance	Stable operation	0.1	–	–	$\mu\text{F}$
<b>Power Stage</b>						
$I_{lim}$	Current limit		3.6	4.5	6.5	A
$T_{lim}$	Temperature shutdown		–	+150	–	$^{\circ}\text{C}$
	Temperature shutdown hysteresis		–	20	–	$^{\circ}\text{C}$

### NOTE:

- Limits are 100% production tested at  $25\text{ }^{\circ}\text{C}$ . Limits over the operating temperature range are guaranteed through correlation using Statistical Quality Control (SQC) methods.
- Ceramic capacitors only. Low ESR electrolytic capacitors are not necessary.
- Voltage Accuracy referred to voltage at ExtRefIn pin.
- RefOut voltage referenced to  $1/2 V_{DD}$  if ExtRefIn not connected.
- $V_{ACC} = V_{TT} - V_{DD}/2$ .

# Advanced DDR memory termination power with external reference in

NE57810

## TYPICAL PERFORMANCE CURVES

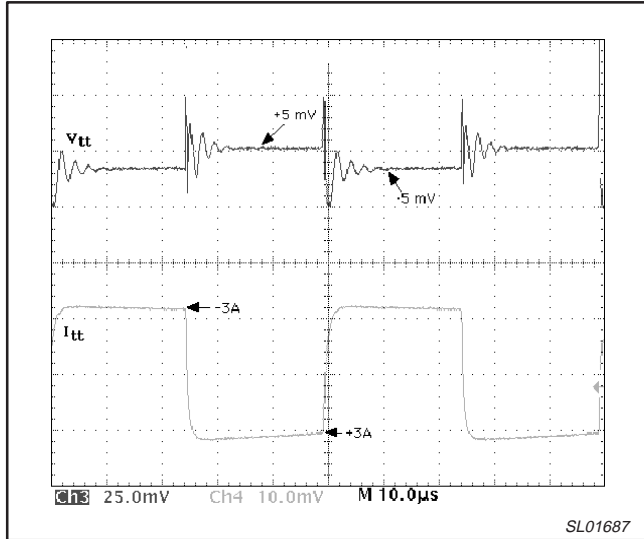

Figure 3.  $V_{TT}$  transient response (output filter 50  $\mu$ F ceramic)

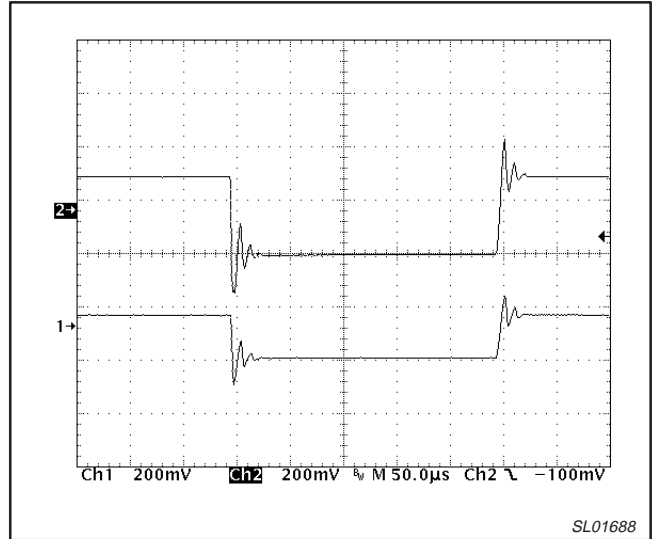

Figure 4.  $V_{DD}$ -to- $V_{TT}$  response (output filter 50  $\mu$ F ceramic)

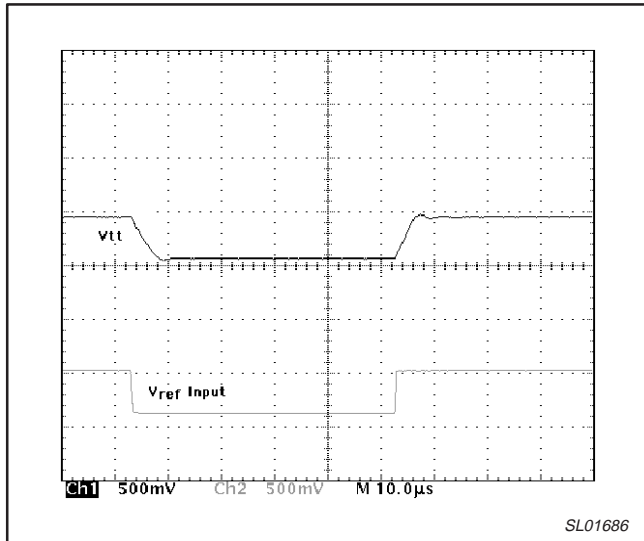

Figure 5.  $V_{ref}$ -to- $V_{TT}$  transient response (output filter 820  $\mu$ F + 50  $\mu$ F ceramic)

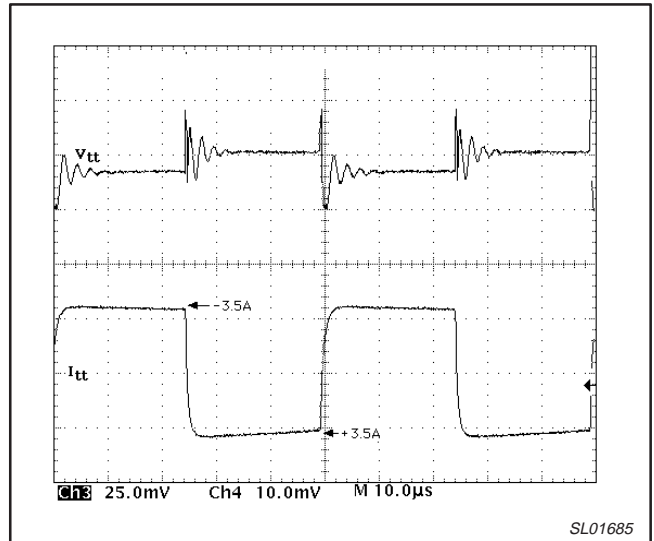

Figure 6.  $V_{ref}$ -to- $V_{TT}$  transient response (output filter 50  $\mu$ F ceramic)

Advanced DDR memory termination power  
with external reference in

NE57810

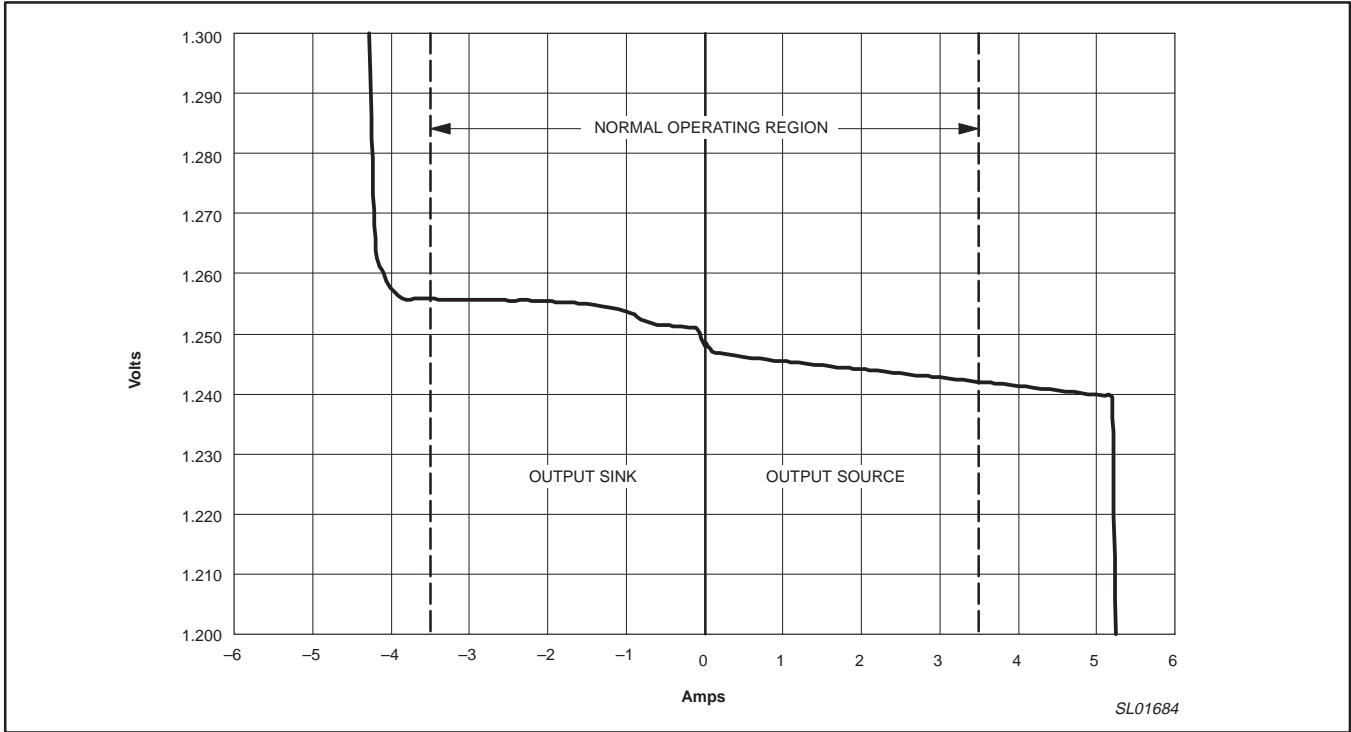

Figure 7. Typical  $V_{TT}$  versus output current ( $V_{DD} = 2.5\text{ V @ }25\text{ °C}$ )

# Advanced DDR memory termination power with external reference in

NE57810

## TECHNICAL DISCUSSION

The NE57810 supplies power to the DDR memory bus termination resistors at nominally  $1/2$  the voltage supplied to the memory ICs or DIMMs. DDR memory output drivers source and sink current into and out of their outputs. A typical DDR memory system is seen in Figure 1 (page 2). Each input/output pin on the bus has a series  $20 \Omega$  resistor connected to it. The bus is terminated to the DDR terminator through a  $27$  to  $50 \Omega$  resistance. The memory system will then require current from the  $V_{TT}$  terminator bus only when the instantaneous value of the aggregate bus state are not equal amounts of 1s and 0s. When memory bus speeds are in the  $200$ – $300$  MHz region, the period of any single bus state is extremely small. This permits the DDR bus termination regulator to be a linear 'power Op Amp' that can source and sink current instantly to the DDR bus from the  $V_{DD}$  supply voltage.

Figure 8 models the  $V_{TT}$  loading condition of each bus line equivalent circuit during operation and with terminating resistors.

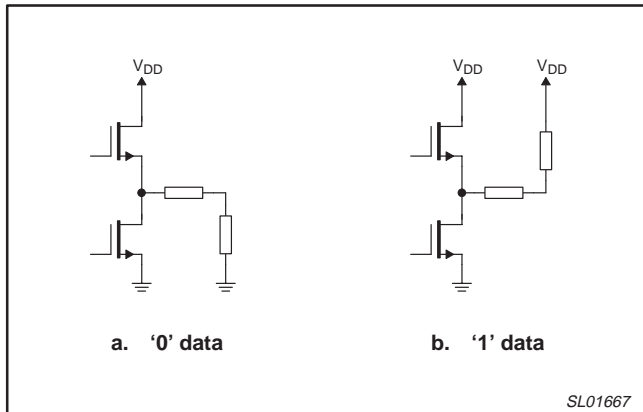

Figure 8.  $V_{TT}$  loading conditions.

This yields the worst case current loading equation:

$$I_{O(max)} = \frac{N_{DDR} V_{DD}}{2(R_T + R_S)}$$

Where:

$N_{DDR}$  is the total number of terminated control, address and data lines within the DDR memory system. (typically 192)

$R_T$  is the value of the terminating resistors.

$R_S$  is the value of the series resistors from the active output driver.

Hence the worst-case current loading condition, where there are either all 1s or all 0s for an instant, and  $R_T$  is  $27 \Omega$  and  $R_S$  is  $20 \Omega$ , produces an instantaneous output current of either + or – 3.5 Amperes.

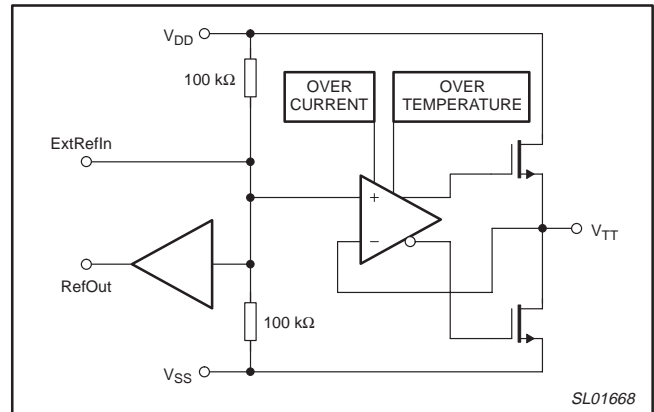

Figure 9. Block diagram.

# Advanced DDR memory termination power with external reference in

NE57810

## THERMAL DESIGN

Designing the proper thermal system for the NE57810 is important to its reliable operation. The NE57810 will be operating at an average power level less than the maximum rating of the part. In a typical DDR terminator system the average power dissipation is between 0.8 and 1.5 watts. The termination power will vary as the average number of '1s' and '0s' changes during normal operation of the DDR memory. The load current will assume a new value for each bus cycle at a 266 MHz rate, and will increase and decrease as the statistical average of bus states change.

The terminator heatsink must be designed to accommodate the average power as a steady state condition and be able to withstand momentary periods of increased dissipation, typically 2 – 5 seconds duration. For the typical NE57810 application, the power dissipated by the terminator can be calculated:

$$P_D = I_{DD(VTT)} \text{ Watts} \tag{Eqn. (1)}$$

The thermal resistance of a surface mount package is given as  $R_{th(j-a)}$ , the thermal resistance from the junction to air. JESD51-7 specifies a 4-layer multilayer PCB (2oz/1oz/1oz/2oz copper) that is 4 inches on each side. This is probably the best (or lowest) thermal resistance you will see in any application. Most applications cannot afford the PCB area to create this situation, but the thermal performance of a multilayer PCB will still provide a significant heatsinking effect. The actual thermal resistance will be higher than the 16.5 °C/W given for the 4-layer JEDEC PCB.

Figure 10 shows the thermal resistance you can expect for heatsinking PCB areas less than the JEDEC specification. The graph is for a 2 oz. single-sided PCB with a square area of the side

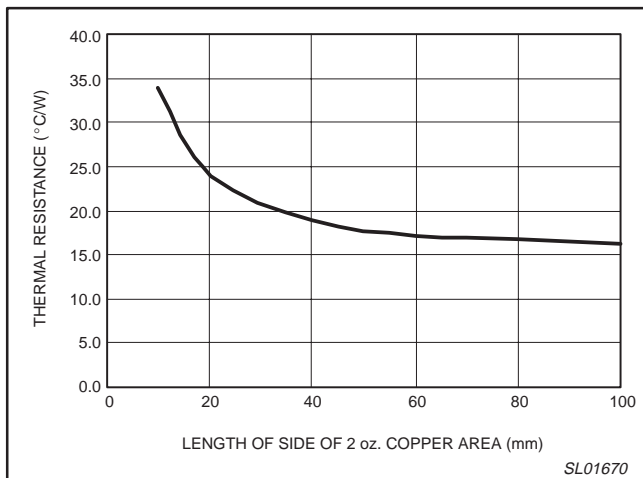

Figure 10. PCB heatsink area versus thermal resistance.

dimension as given on the X axis. If you use a double-sided PCB with some plated-through holes to help transfer heat to the bottom side, the thermal resistance only improves by about 3 – 4 °C/W.

After the power is estimated, the minimum PCB area can be determined by calculating the worst case thermal resistance and referring to Figure 10 to determine the PCB area. This is done by:

$$R_{qJA(min)} = \frac{T_j - T_{amb}}{P_D} \tag{Eqn. (2)}$$

Where:

- $T_j$  is the maximum desired junction temperature
- $T_{amb}$  is the highest expected local ambient temperature
- $P_D$  is the estimated average power

The junction temperature should be kept well away from the over-temperature cutoff threshold temperature (+150 °C) in normal operation.

Using the above power dissipation, the highest ambient temperature and a junction temperature of +125 °C, calculate the maximum thermal resistance (1.5 watts is used only as an example).

$$R_{th(j-a)(min)} = \frac{125 \text{ } ^\circ\text{C} - 70 \text{ } ^\circ\text{C}}{1.5 \text{ W}} = 36.6 \text{ } ^\circ\text{C/W} \tag{Eqn. (3)}$$

Looking at Figure 10, you see that this power dissipation requires a minimum PCB island area of 225 mm<sup>2</sup> (15 mm on each side). This is the smallest area you could use at this power dissipation. Of course, increasing this area will allow the NE57810 to operate at cooler temperatures, thus enhancing its long-term reliability.

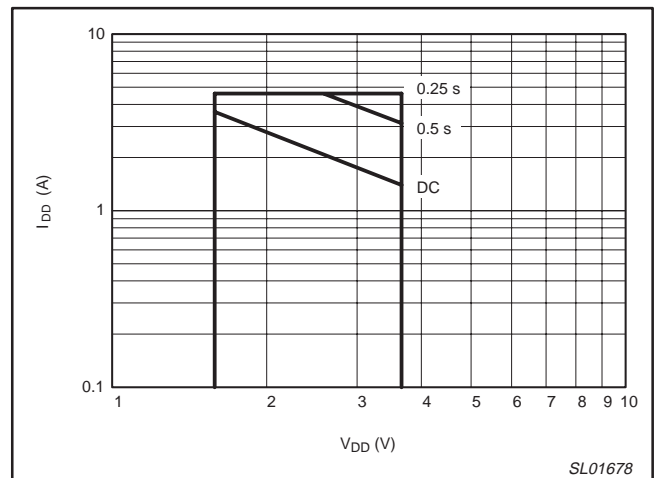

Figure 11. Safe operating area for the NE57810.



## Advanced DDR memory termination power with external reference in

NE57810

### APPLICATION INFORMATION

The NE57810 can be used in a variety of DDR memory configurations. Its small footprint, fast transient response and lessened need for large bulk output capacitance, makes it highly adaptable. Some of these methods of use are given below.

#### Normal operating mode ( $V_{TT} = V_{DDR}/2$ )

The most common implementation of a DDR terminator regulator using the NE57810 is shown in Figure 12. The NE57810 has an internal resistor divider between the  $V_{DD}$  (pin 2) and  $V_{SS}$  (pin 3) pins which maintains the output voltage,  $V_{TT}$ , at  $V_{DD}/2$ . Typically, the  $V_{DD}$  voltage is the DDR RAM supply voltage, which can range from 1.8 V to 2.5 V. The center node of this resistor divider is brought out to ExtRefIn (pin 4). This node acts as the reference for the  $V_{TT}$  output voltage and the buffered RefOut signal (pin 5).

If the ExtRefIn pin is not connected to other voltage sources, then two small bypass capacitors (0.01  $\mu\text{F}$ ) should be placed between the ExtRefIn pin and the GND and  $V_{DD}$  pins to improve the terminator's noise performance. The two ExtRefIn bypass capacitors connected as shown in Figure 12 allow the terminator to better track any variations in the memory  $V_{DD}$  voltage. This method can be seen in Figure 12.

There are two components to the memory signal load: a high frequency component caused by the 266 MHz plus speed of the

address, data, and control buses, and a low frequency component caused by the time-average skew of all of the bus states away from an equal number of 1s and 0s. Electrolytic and tantalum capacitor appear inductive at the high frequencies. Therefore two types of capacitors are needed for the output filtering.

A very good, low ESR electrolytic capacitor of no less than 470  $\mu\text{F}$  should be placed next to the terminator, which should be placed as close as possible to the memory array. One half of the high frequency filter capacitors should be to  $V_{DD}$  and the other half to  $V_{SS}$  so that the output will better track any variations in the  $V_{DD}$  voltage.

For different memory sizes, the values of the recommended output filter capacitances will change. For a 256 MByte memory space, for example, approximately 100  $\mu\text{F}$  of ceramic surface mount chip capacitors should be evenly distributed across the physical memory layout. Depending upon the PCB noise environment, this could be 10 pieces of 10  $\mu\text{F}$ , 20 pieces of 5  $\mu\text{F}$ , and so on.

It might be possible to reduce the total capacitance, provided the performance remains stable. Examine the behavior of the  $V_{TT}$  bus carefully when the system is operating and verify that deviations in the bus voltage do not exceed the DDR specification ( $\pm 40$  mV).

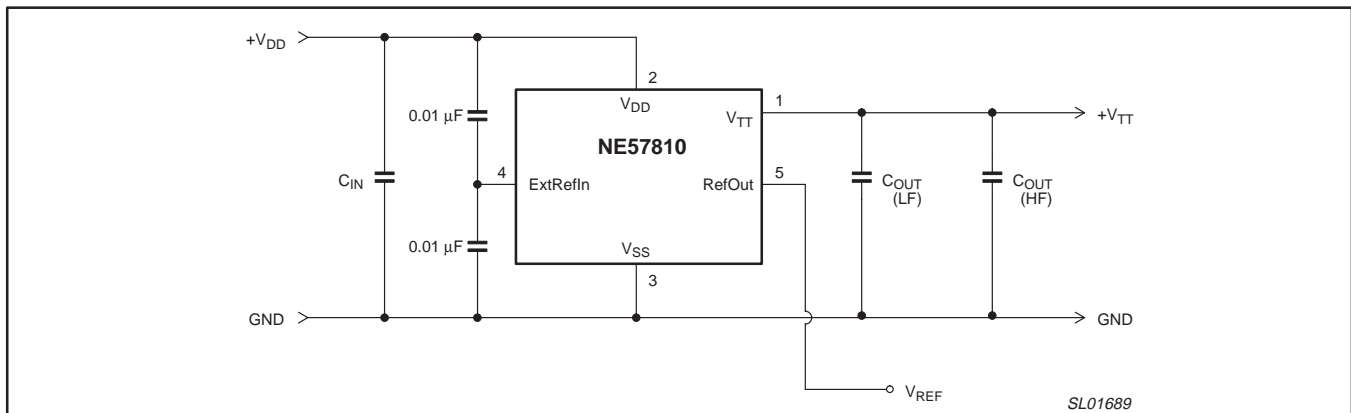

Figure 12. Normal operating method ( $V_{TT} = V_{DD}/2$ )

# Advanced DDR memory termination power with external reference in

## NE57810

### Externally programmed $V_{TT}$ output voltage

The NE57810 allows use of an external reference voltage to set its  $V_{TT}$  output voltage. This pin (ExtRefIn pin 4) is used for applications where the  $V_{TT}$  voltage is not  $V_{DD}$  divided by 2. This allows  $V_{TT}$  voltage and current to be drawn from a power supply bus that is not the DDR RAM supply voltage. This may have some advantages when you are attempting to better match the power being drawn from the outputs emerging from main system power supply. This can be seen in Figure 13.

The internal reference voltage is set by two matched 100 k $\Omega$  resistors connected in a resistor divider between the  $V_{DD}$  and  $V_{SS}$  pins of the NE57810.

Setting the value of  $V_{ref}$  or  $V_{TT}$  can be done in two ways: by placing an external resistor divider whose resistor values are less than 5 k $\Omega$  each or by connecting the output of an operational amplifier that is outputting the reference voltage. If the external resistor divider is used, place a 0.01  $\mu$ F ceramic bypass capacitor between the ExtRefIn pin (pin 4) and the  $V_{SS}$  pin (pin 3). The accuracy of the new reference voltage when the external resistor divider is used will be about 0.5 percent PLUS the sum of the tolerances of the resistors used in the divider.

Please note that when the NE57810 is operating in this fashion, the power dissipation of the part may increase.

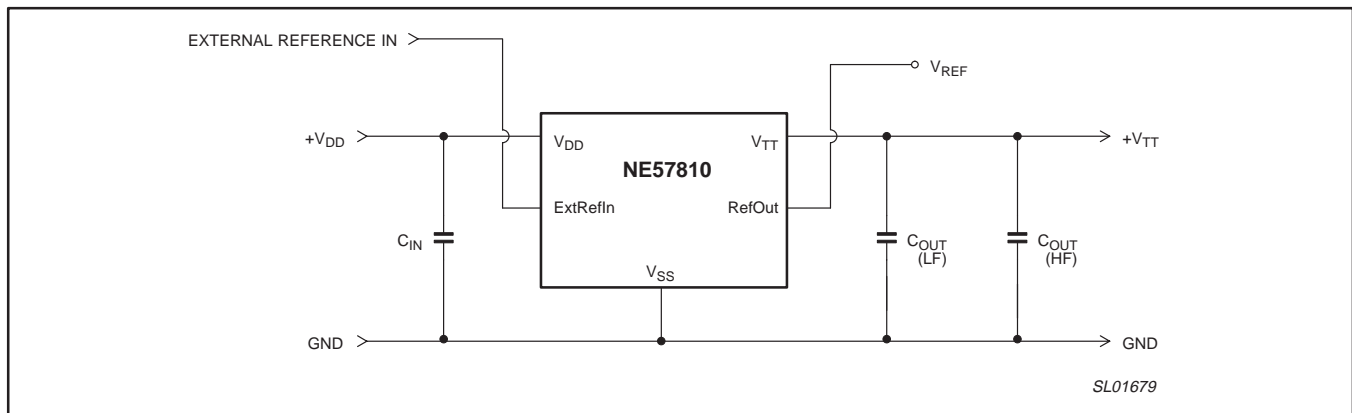

Figure 13. Externally programmed  $V_{TT}$ .

# Advanced DDR memory termination power with external reference in

## NE57810

### Cascading the NE57810 for complex memory systems

For high-performance computer systems, sometimes memory banks are driven 180 degrees out of phase with one another such that the apparent access time is halved (even and odd memory addresses). To do this, it is recommended that two NE57810s are used, one to terminate each memory bank.

Cascading NE57810 terminators offers two advantages, it improves the system noise performance by bringing the memory SIMMs closer to the terminator, and distributes any heat generated by the

terminator system. By using the RefOut pin from one NE57810 to the ExtRefIn pin for the other NE57810(s) used in the system, one can always guarantee that the  $V_{TT}$  voltages are identical. Because of the very tight output voltage regulation of the NE57810, the  $V_{TT}$  outputs should never be wired together. This is because the terminators would 'fight' one another if their output were different by only a few millivolts. This method can be used in either the normal operating mode and the externally programmed operating mode. This method of use can be seen in Figure 14.

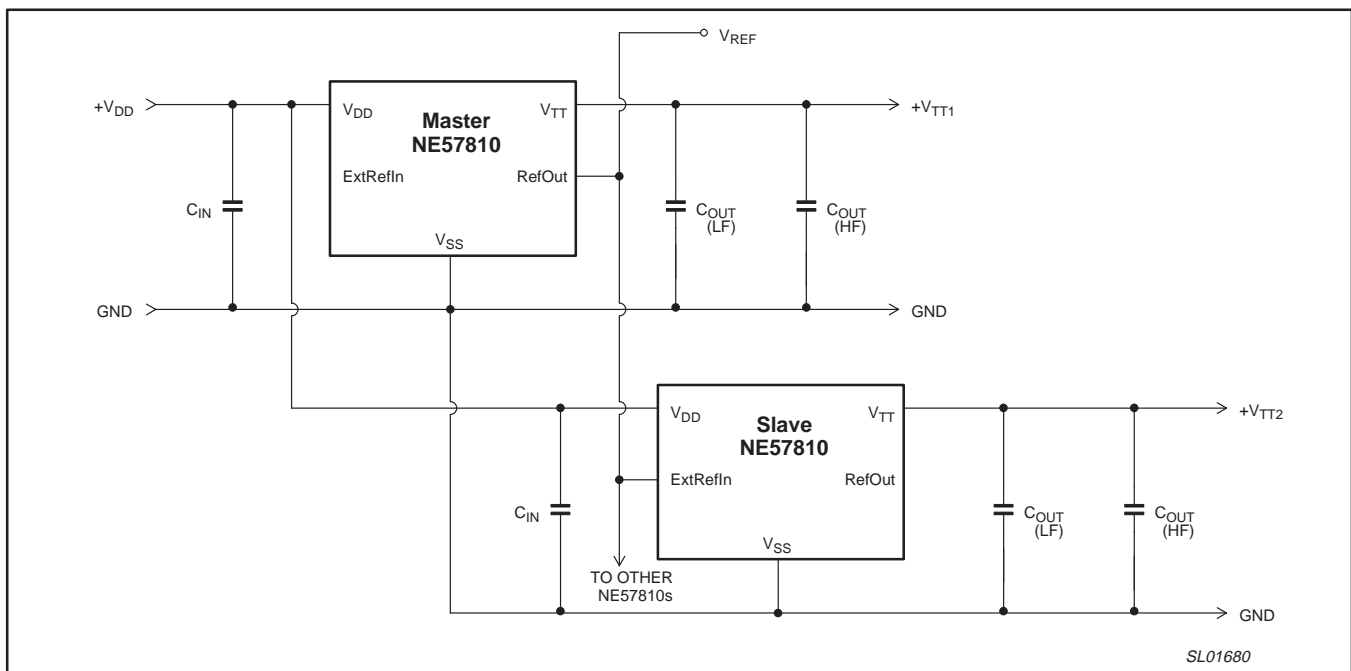
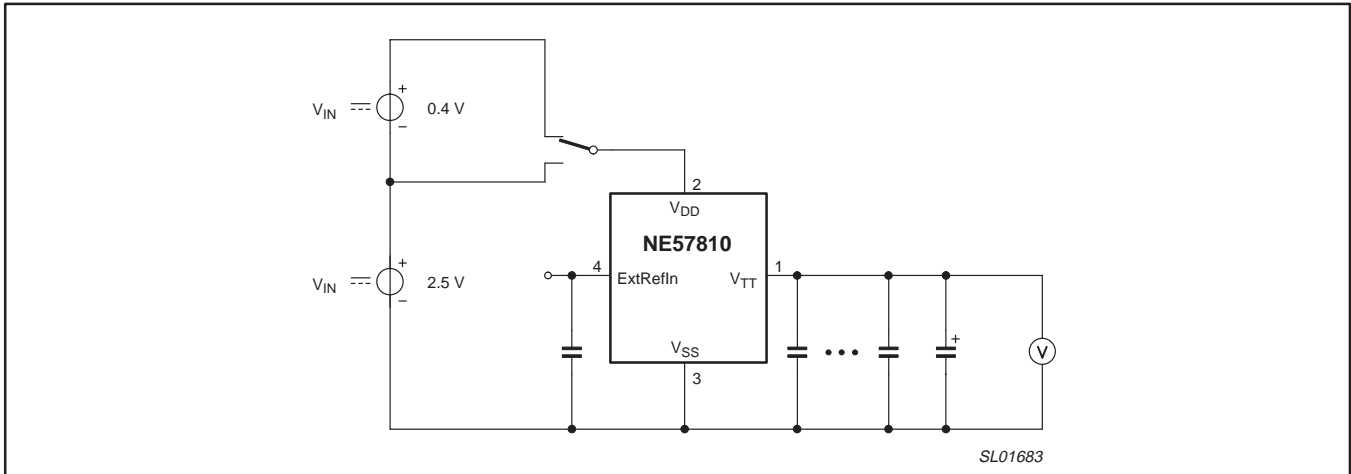
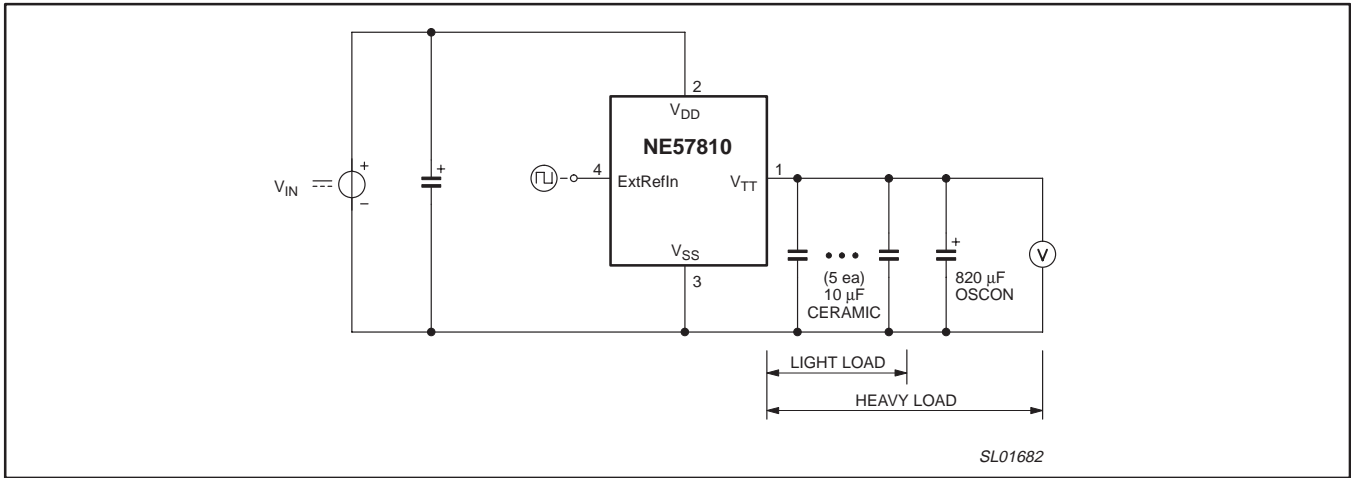
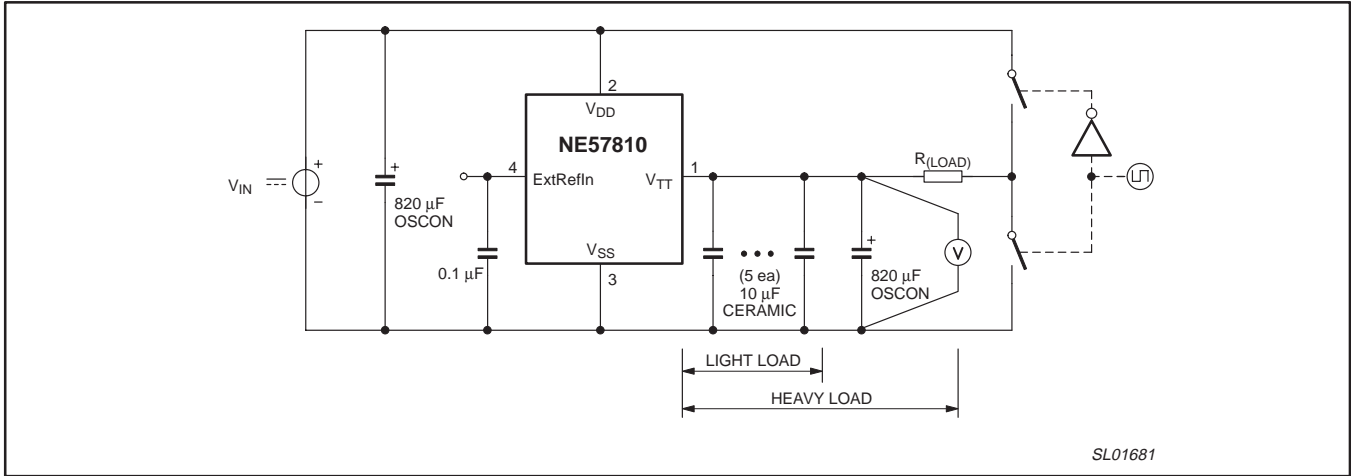

Figure 14. Cascading terminator systems for complex memory systems.

# Advanced DDR memory termination power with external reference in

## NE57810

### TEST CIRCUITS



# Advanced DDR memory termination power with external reference in

NE57810

## PACKING METHOD

The NE57810 is packed in reels, as shown in Figure 18.

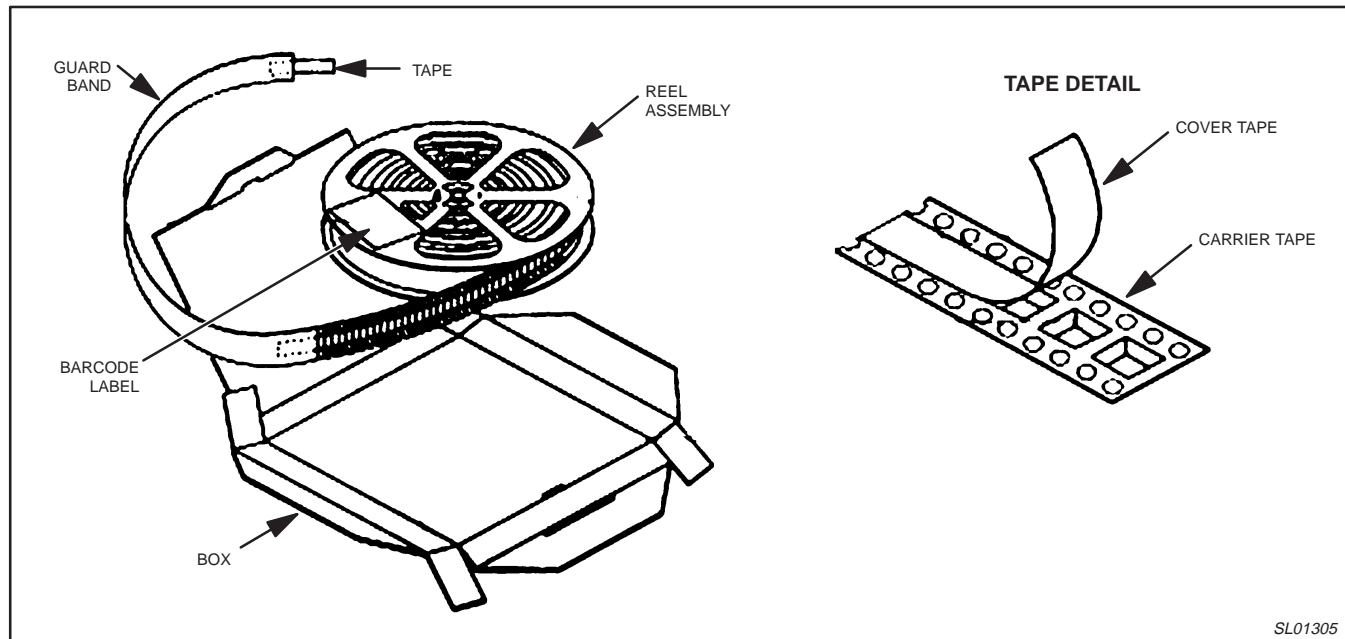

Figure 18. Tape and reel packing method.

Advanced DDR memory termination power  
with external reference in

NE57810

Plastic single-ended surface mounted package; 5 leads

SOT756

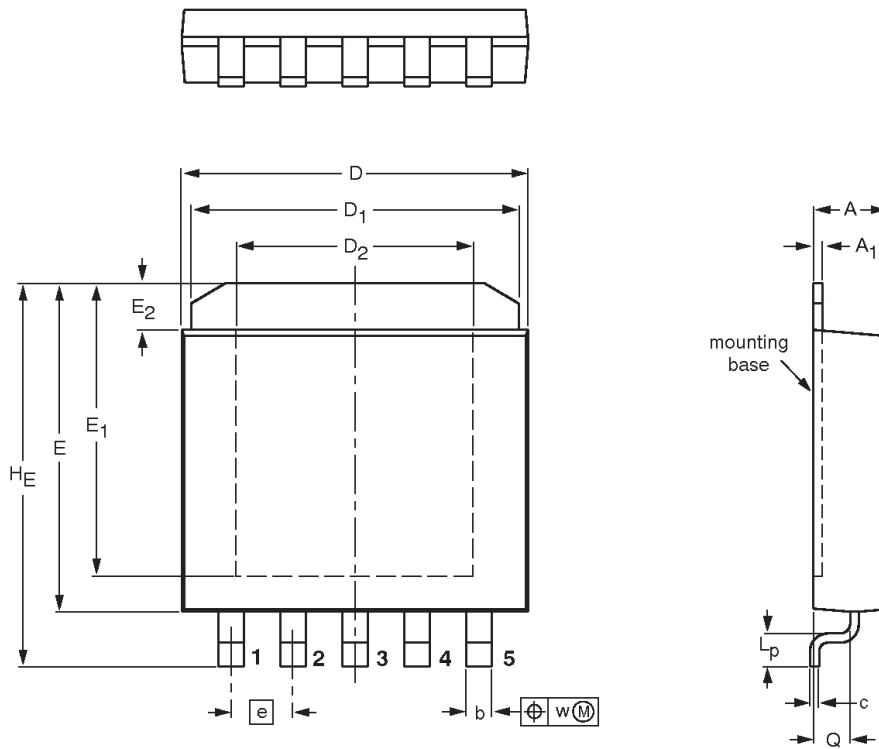

**DIMENSIONS (mm are the original dimensions)**

UNIT	A	A <sub>1</sub> max.	b	c max.	D	D <sub>1</sub>	D <sub>2</sub> max.	E	E <sub>1</sub> max.	E <sub>2</sub>	e	H <sub>E</sub>	L <sub>p</sub>	Q	w
mm	2.03 1.78	0.25	0.79 0.63	0.25	9.52 9.27	9.14 8.89	6.5	9.40 8.63	8.03	1.27 0.76	1.7	10.67 10.41	1.04 0.79	1.14 0.89	0.25

OUTLINE VERSION	REFERENCES				EUROPEAN PROJECTION	ISSUE DATE
	IEC	JEDEC	JEITA			
SOT756						02-03-25 02-03-29

# Advanced DDR memory termination power with external reference in

NE57810

## REVISION HISTORY

Rev	Date	Description
_2	20030912	<p><b>Product data (9397 750 11214). ECN 853-2359 29723 of 28 March 2003.</b>  <b>Supersedes data of 16 July 2002 (9397 750 10147).</b></p> <p>Modifications:</p> <ul style="list-style-type: none"> <li>● Page 4, Electrical characteristics table: <ul style="list-style-type: none"> <li>– (description): from “<math>T_{amb} = 25\text{ °C}</math>” to “<math>T_{amb} = 0\text{ °C to }+70\text{ °C}</math>”</li> <li>– Output voltage accuracy: add symbol “<math>V_{ACC}</math>”; add Note 5; change Min. value from “–10” to “–15”; change Max. value from “+10” to “+15”.</li> <li>– <math>I_Q</math>: change Typ. value from “20” to “14”.</li> <li>– <math>I_{TT}</math>: change Condition from “<math>V_{DD} = 2.25 - 3.6\text{ V}</math>” to “<math>2.5\text{ V} \leq V_{DD} \leq 3.6\text{ V}</math>”.</li> <li>– Output voltage accuracy: change Min. value from “–10” to “–15”; change Max. value from “+10” to “+15”.</li> <li>– RefOut: add condition “IrefOut = 0 A; source or sink”; change Min. value from “–10” to “–15”; change Max. value from “+10” to “+15”.</li> <li>– Change subheading row from “Protection” to “Power Stage”.</li> </ul> </li> <li>● Modify Figure 12 on page 9.</li> </ul>
_1	20020716	<b>Product data (9397 750 10147). ECN 853-2359 28625 of 17 July 2002.</b>

# Advanced DDR memory termination power with external reference in

NE57810

## Data sheet status

Level	Data sheet status [1]	Product status [2] [3]	Definitions
I	Objective data	Development	This data sheet contains data from the objective specification for product development. Philips Semiconductors reserves the right to change the specification in any manner without notice.
II	Preliminary data	Qualification	This data sheet contains data from the preliminary specification. Supplementary data will be published at a later date. Philips Semiconductors reserves the right to change the specification without notice, in order to improve the design and supply the best possible product.
III	Product data	Production	This data sheet contains data from the product specification. Philips Semiconductors reserves the right to make changes at any time in order to improve the design, manufacturing and supply. Relevant changes will be communicated via a Customer Product/Process Change Notification (CPCN).

[1] Please consult the most recently issued data sheet before initiating or completing a design.

[2] The product status of the device(s) described in this data sheet may have changed since this data sheet was published. The latest information is available on the Internet at URL <http://www.semiconductors.philips.com>.

[3] For data sheets describing multiple type numbers, the highest-level product status determines the data sheet status.

## Definitions

**Short-form specification** — The data in a short-form specification is extracted from a full data sheet with the same type number and title. For detailed information see the relevant data sheet or data handbook.

**Limiting values definition** — Limiting values given are in accordance with the Absolute Maximum Rating System (IEC 60134). Stress above one or more of the limiting values may cause permanent damage to the device. These are stress ratings only and operation of the device at these or at any other conditions above those given in the Characteristics sections of the specification is not implied. Exposure to limiting values for extended periods may affect device reliability.

**Application information** — Applications that are described herein for any of these products are for illustrative purposes only. Philips Semiconductors make no representation or warranty that such applications will be suitable for the specified use without further testing or modification.

## Disclaimers

**Life support** — These products are not designed for use in life support appliances, devices, or systems where malfunction of these products can reasonably be expected to result in personal injury. Philips Semiconductors customers using or selling these products for use in such applications do so at their own risk and agree to fully indemnify Philips Semiconductors for any damages resulting from such application.

**Right to make changes** — Philips Semiconductors reserves the right to make changes in the products—including circuits, standard cells, and/or software—described or contained herein in order to improve design and/or performance. When the product is in full production (status 'Production'), relevant changes will be communicated via a Customer Product/Process Change Notification (CPCN). Philips Semiconductors assumes no responsibility or liability for the use of any of these products, conveys no license or title under any patent, copyright, or mask work right to these products, and makes no representations or warranties that these products are free from patent, copyright, or mask work right infringement, unless otherwise specified.

## Contact information

For additional information please visit

<http://www.semiconductors.philips.com>. Fax: +31 40 27 24825

© Koninklijke Philips Electronics N.V. 2003  
All rights reserved. Printed in U.S.A.

Date of release: 09-03

For sales offices addresses send e-mail to:

[sales.addresses@www.semiconductors.philips.com](mailto:sales.addresses@www.semiconductors.philips.com)

Document order number:

9397 750 11214

*Let's make things better.*