

**INTEGRATED CIRCUITS**

# DATA SHEET

## TEA5570

### RF/IF circuit for AM/FM radio

Product specification  
File under Integrated Circuits, IC01

September 1987

**RF/IF circuit for AM/FM radio****TEA5570****GENERAL DESCRIPTION**

The TEA5570 is a monolithic integrated radio circuit for use in portable receivers and clock radios. The IC is also applicable to mains-fed AM and AM/FM receivers and car radio-receivers. Apart from the AM/FM switch function the IC incorporates for AM a double balanced mixer, 'one-pin' oscillator, i.f. amplifier with a.g.c. and detector, and a level detector for tuning indication. The FM circuitry comprises i.f. stages with a symmetrical limiter for a ratio detector. A level detector for mono/stereo switch information and/or indication complete the FM part.

**Features**

- Simple d.c. switching for AM to FM by only one d.c. contact to ground (no switch contacts in the i.f. channel, a.f. or level detector outputs)
- AM and FM gain control
- Low current consumption ( $I_{\text{tot}} = 6 \text{ mA}$ )
- Low voltage operation ( $V_P = 2,7 \text{ to } 9 \text{ V}$ )
- Ability to handle large AM signals; good i.f. suppression
- Applicable for inductive, capacitive and diode tuning
- Double smoothing of a.g.c. line
- Short-wave range up to 30 MHz
- Lumped or distributed i.f. selectivity with coil and/or ceramic filters
- AM and a.g.c. output voltage control
- Distribution of PCB wiring provides good frequency stability
- Economic design for 'AM only' receivers.

**QUICK REFERENCE DATA (at  $T_{\text{amb}} = 25 \text{ }^\circ\text{C}$ )**

|  |                  |      |                   |
|--|------------------|------|-------------------|
| Supply voltage   | $V_P = V_{7-16}$ | typ. | 5,4 V             |
| Supply current   | $I_7$            | typ. | 6,2 mA            |
| AM performance (pin 2) for $m = 0,3$                         |                  |      |                   |
| Sensitivity  |                  |      |                   |
| at $V_o = 10 \text{ mV}$                                     | $V_i$            | typ. | 1,7 $\mu\text{V}$ |
| at $S/N = 26 \text{ dB}$                                     | $V_i$            | typ. | 16 $\mu\text{V}$  |
| A.F. output voltage at $V_i = 1 \text{ mV}$                  | $V_o$            | typ. | 100 mV            |
| Total harmonic distortion at $V_i = 1 \text{ mV}$            | THD              | typ. | 0,5 %             |
| FM performance (pin 1) for $\Delta f = \pm 22,5 \text{ kHz}$ |                  |      |                   |
| limiting sensitivity, $-3 \text{ dB}$                        | $V_i$            | typ. | 110 $\mu\text{V}$ |
| Signal-to-noise ratio for $V_i = 1 \text{ mV}$               | S/N              | typ. | 65 dB             |
| A.F. output voltage at $V_i = 1 \text{ mV}$                  | $V_o$            | typ. | 100 mV            |
| Total harmonic distortion at $V_i = 1 \text{ mV}$            | THD              | typ. | 0,3 %             |
| AM suppression at $V_i = 10 \text{ mV}$                      | AMS              | typ. | 50 dB             |

**PACKAGE OUTLINE**

16-lead DIL; plastic (SOT38); SOT38-1; 1996 July 25.

RF/IF circuit for AM/FM radio

TEA5570

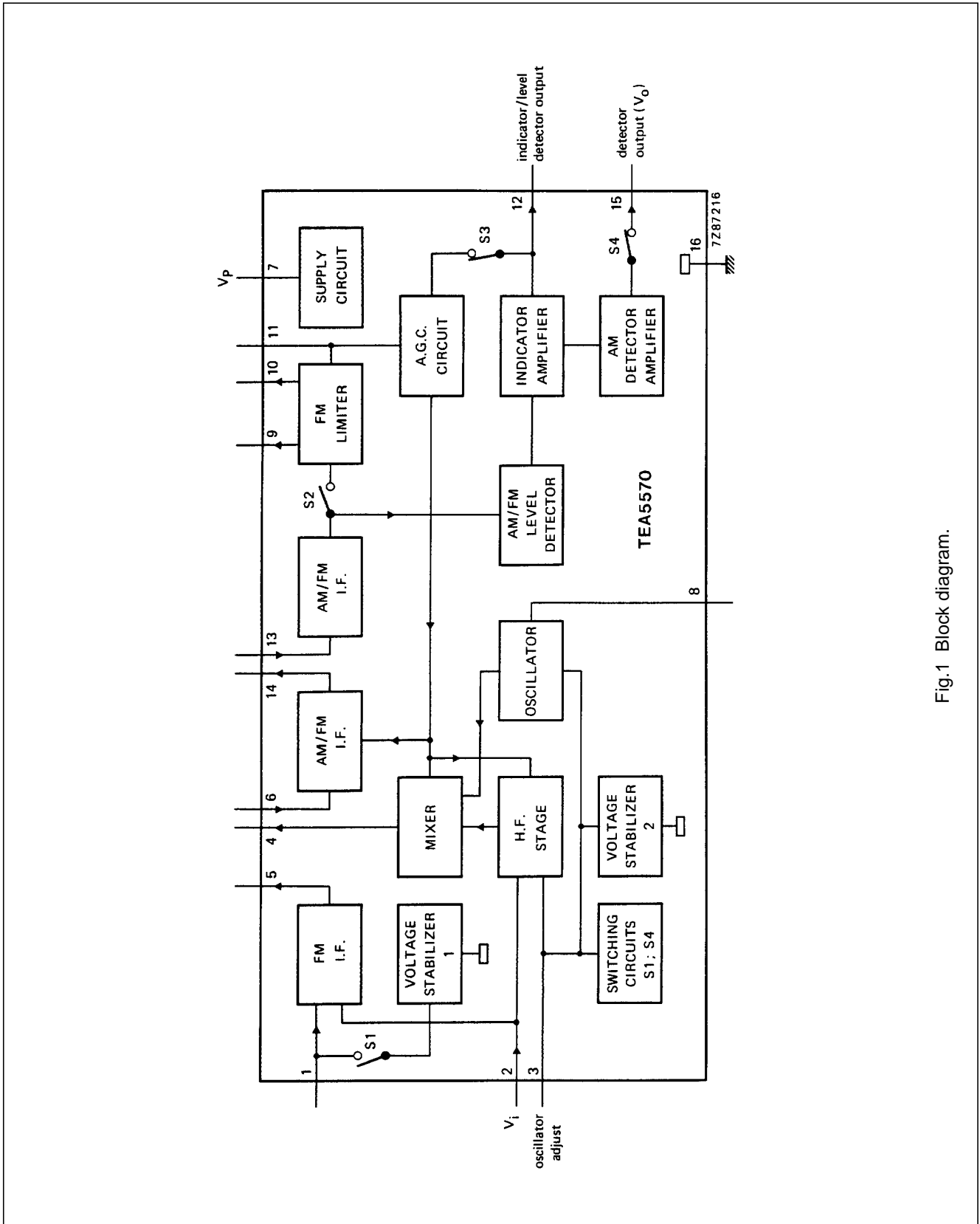

Fig.1 Block diagram.

RF/IF circuit for AM/FM radio

TEA5570

**RATINGS**

Limiting values in accordance with the Absolute Maximum System (IEC 134)

|   |                  |      |                 |
|---|------------------|------|-----------------|
| Supply voltage (pin 7)                            | $V_P = V_{7-16}$ | max. | 12 V            |
| Voltage at pins 4, 5, 9 and 10 to pin 16 (ground) | $V_{n-16}$       | max. | 12 V            |
| Voltage range at pin 8                            | $V_{8-16}$       |      | $V_P \pm 0,5 V$ |
| Current into pin 5                                | $I_5$            | max. | 3 mA            |
| Total power dissipation                           | $P_{tot}$        |      | see Fig.2       |
| Storage temperature range                         | $T_{stg}$        |      | -55 to +150 °C  |
| Operating ambient temperature range               | $T_{amb}$        |      | -30 to +85 °C   |

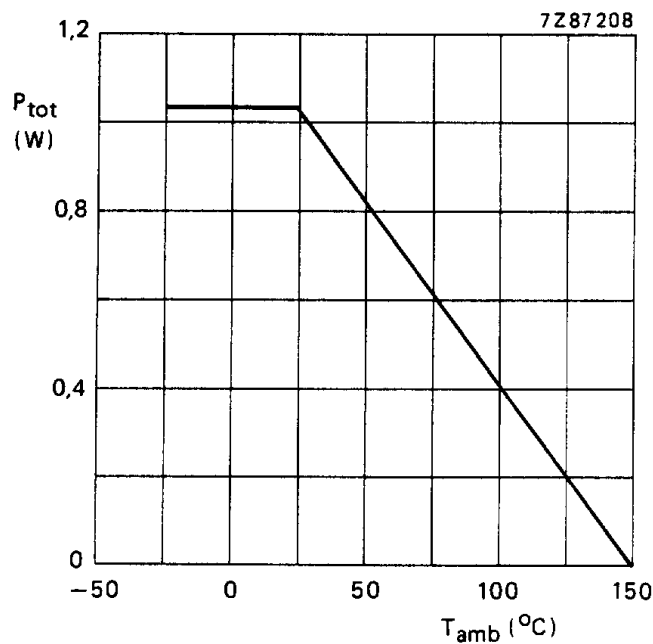

Fig.2 Power derating curve.

## RF/IF circuit for AM/FM radio

## TEA5570

**D.C. CHARACTERISTICS**

$V_P = 6\text{ V}$ ;  $T_{\text{amb}} = 25\text{ °C}$ ; measured in Fig.10; unless otherwise specified

| PARAMETER                                     | SYMBOL           | MIN. | TYP. | MAX. | UNIT          |
|---|------------------|------|------|------|---------------|
| <b>Supply</b> (pin 7)                         |                  |      |      |      |               |
| Supply voltage (note 1)                       | $V_P = V_{7-16}$ | 2,4  | 5,4  | 9,0  | V             |
| <b>Voltages</b>                               |                  |      |      |      |               |
| at pin 1 (FM)                                 | $V_{1-16}$       | –    | 1,42 | –    | V             |
| at pin 1; $-I_1 = 50\text{ }\mu\text{A}$ (FM) | $V_{1-16}$       | –    | 1,28 | –    | V             |
| at pins 2 and 3 (AM)                          | $V_{2,3-16}$     | –    | 1,42 | –    | V             |
| at pin 6                                      | $V_{6-16}$       | –    | 0,7  | –    | V             |
| at pin 11                                     | $V_{11-16}$      | –    | 1,4  | –    | V             |
| at pin 13                                     | $V_{13-16}$      | –    | 0,7  | –    | V             |
| at pin 14                                     | $V_{14-16}$      | –    | 4,3  | –    | V             |
| <b>Currents</b>                               |                  |      |      |      |               |
| Supply current                                | $I_7$            | 4,2  | 6,2  | 8,2  | mA            |
| Current supplied from pin 1 (FM)              | $-I_1$           | –    | –    | 50   | $\mu\text{A}$ |
| Current supplied from pin 12                  | $-I_{12}$        | –    | –    | 20   | $\mu\text{A}$ |
| Current supplied from pin 15                  | $-I_{15}$        | –    | 30   | –    | $\mu\text{A}$ |
| Current into pin 4 (AM)                       | $I_4$            | –    | 0,6  | –    | mA            |
| Current into pin 5 (FM) (note 4)              | $I_5$            | –    | 0,35 | –    | mA            |
| Current into pin 8 (AM)                       | $I_8$            | –    | 0,3  | –    | mA            |
| Current into pins 9, 10 (FM)                  | $I_{9,10}$       | –    | 0,65 | –    | mA            |
| Current into pin 14                           | $I_{14}$         | –    | 0,4  | –    | mA            |
| <b>Power consumption</b>                      | $P$              | –    | 40   | –    | mW            |

## RF/IF circuit for AM/FM radio

## TEA5570

**A.C. CHARACTERISTICS****AM performance**

$V_P = 6\text{ V}$ ;  $T_{\text{amb}} = 25\text{ °C}$ ; r.f. condition:  $f_i = 1\text{ MHz}$ ,  $m = 0,3$ ,  $f_m = 1\text{ kHz}$ ; transfer impedance of the i.f. filter

$|Z_{\text{tr}}| = v_6/i_4 = 2,7\text{ k}\Omega$ ; measured in Fig.10; unless otherwise specified

| PARAMETER  | SYMBOL     | MIN. | TYP. | MAX. | UNIT          |
|--|------------|------|------|------|---------------|
| R.F. sensitivity (pin 2)   |            |      |      |      |               |
| at $V_o = 30\text{ mV}$  | $V_i$      | 3,5  | 5,0  | 7,0  | $\mu\text{V}$ |
| at $S + N/N = 6\text{ dB}$   | $V_i$      | –    | 1,3  |      | $\mu\text{V}$ |
| at $S + N/N = 26\text{ dB}$  | $V_i$      | –    | 16   | 20   | $\mu\text{V}$ |
| at $S + N/N = 50\text{ dB}$  | $V_i$      | –    | 1    | –    | mV            |
| Signal handling (THD $\leq 10\%$ at $m = 0,8$ )                    | $V_i$      | 200  | –    | –    | mV            |
| A.F. output voltage at $V_i = 1\text{ mV}$                         | $V_o$      | 80   | 100  | 125  | mV            |
| Total harmonic distortion  |            |      |      |      |               |
| at $V_i = 100\text{ }\mu\text{V}$ to $100\text{ mV}$ ( $m = 0,3$ ) | THD        | –    | 0,5  | –    | %             |
| at $V_i = 2\text{ mV}$ ( $m = 0,8$ )                               | THD        | –    | 1,0  | 2,5  | %             |
| at $V_i = 200\text{ mV}$ ( $m = 0,8$ )                             | THD        | –    | 4,0  | 10   | %             |
| I.F. suppression at $V_o = 30\text{ mV}$ (note 2)                  | $\alpha$   | 26   | 35   | –    | dB            |
| Oscillator voltage (pin 8; note 3)                                 |            |      |      |      |               |
| at $f_{\text{osc}} = 1455\text{ kHz}$                              | $V_{8-16}$ | 120  | 160  | 200  | mV            |
| Indicator current (pin 12) at $V_i = 1\text{ mV}$                  | $I_{12}$   | –    | 200  | 230  | $\mu\text{V}$ |

**FM performance**

$V_P = 6\text{ V}$ ;  $T_{\text{amb}} = 25\text{ °C}$ ; i.f. condition:  $f_i = 10,7\text{ MHz}$ ,  $\Delta f = \pm 22,5\text{ kHz}$ ,  $f_m = 1\text{ kHz}$ ; transfer impedance of the i.f. filter

$|Z_{\text{tr}}| = v_6/i_5 = 275\text{ }\Omega$ ; measured in Fig.10; unless otherwise specified

| PARAMETER  | SYMBOL | MIN. | TYP. | MAX. | UNIT          |
|--|--------|------|------|------|---------------|
| <b>I.F. part</b>                                 |        |      |      |      |               |
| I.F. sensitivity (adjustable; note 4)            |        |      |      |      |               |
| Input voltage                                    |        |      |      |      |               |
| at $-3\text{ dB}$ before limiting                | $V_i$  | 90   | 110  | 130  | $\mu\text{V}$ |
| at $S + N/N = 26\text{ dB}$                      | $V_i$  | –    | 6    | –    | $\mu\text{V}$ |
| at $S + N/N = 65\text{ dB}$                      | $V_i$  | –    | 1    | –    | mV            |
| A.F. output voltage at $V_i = 1\text{ mV}$       | $V_o$  | 80   | 100  | 125  | mV            |
| Total harmonic distortion at $V_i = 1\text{ mV}$ | THD    | –    | 0,3  | –    | %             |
| AM suppression (note 5)                          | AMS    | –    | 50   | –    | dB            |

## RF/IF circuit for AM/FM radio

## TEA5570

| PARAMETER   | SYMBOL      | MIN. | TYP. | MAX. | UNIT          |
|---|-------------|------|------|------|---------------|
| <b>Indicator/level detector</b> (pin 12)          |             |      |      |      |               |
| Indicator current                                 | $I_{12}$    | –    | 250  | 325  | $\mu\text{A}$ |
| D.C. output voltage<br>at $V_i = 300 \mu\text{V}$ | $V_{12-16}$ | –    | 0,25 | –    | V             |
| at $V_i = 2 \text{ mV}$                           | $V_{12-16}$ | –    | 1,0  | –    | V             |
| <b>AM to FM switch</b>                            |             |      |      |      |               |
| Switching current at $V_{3-16} < 1 \text{ V}$     | $-I_3$      | –    | –    | 400  | $\mu\text{A}$ |

**Notes to the characteristics**

- Oscillator operates at  $V_{7-16} > 2,25 \text{ V}$ .
- I.F. suppression is defined as the ratio  $\alpha = 20 \log \frac{V_{i1}}{V_{i2}}$  where:  $V_{i1}$  is the input voltage at  $f = 455 \text{ kHz}$  and  $V_{i2}$  is the input voltage at  $f = 1 \text{ MHz}$ .
- Oscillator voltage at pin 8 can be preset by  $R_{\text{osc}}$  (see Fig.10).
- Maximum current into pin 5 can be adjusted by R1 (see Fig.10);  $I_5 = \frac{V_{3-16}}{R1} - I_3$  when  $V_{3-16} = 800 \text{ mV}$ ;  $I_3 = 400 \mu\text{A}$ .
- AM suppression is measured with  $f_m = 1 \text{ kHz}$ ,  $m = 0,3$  for AM;  $f_m = 400 \text{ Hz}$ ,  $\Delta f = \pm 22,5 \text{ kHz}$  for FM.

**Facility adaptation**

Facility adaptation is achieved as follows (see Fig.10):

| FACILITY              | COMPONENT   |
|-----------------------|---|
| FM sensitivity        | R1 fixes the current at pin 5 ( $I_5 = \frac{V_{3-16}}{R1} - 400 \mu\text{A}$ )<br>(gain adjustable $\pm 10 \text{ dB}$ ; see note 4) |
| AM sensitivity        | R11 and coil tapping  |
| AM oscillator biasing | $R_{\text{osc}}$  |
| AM output voltage     | R7, R11   |
| AM a.g.c. setting     | R7  |

RF/IF circuit for AM/FM radio

TEA5570

Typical graphs

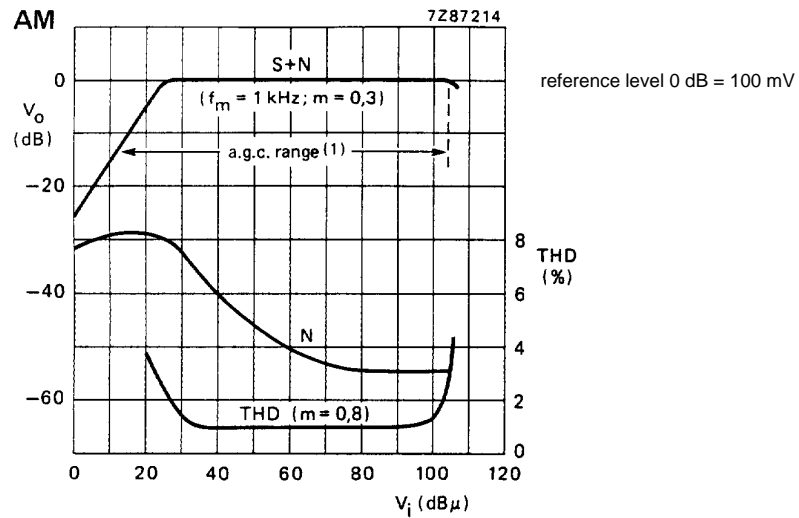

(1) A.G.C. range (figure of merit, FOM).

Fig.3 Signal, noise and distortion as a function of input voltage ( $V_i$ ). Measured at  $f_i = 1 \text{ MHz}$  in test circuit Fig.10.

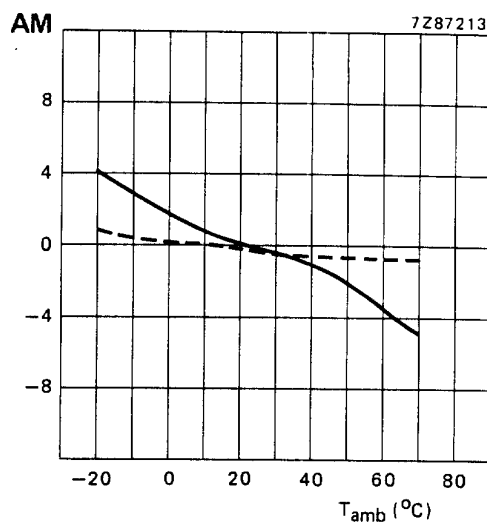

— sensitivity ( $V_i$ ) at  $V_o = 30 \text{ mV}$ ;  $m = 0,3$ .  
 - - - output voltage ( $V_o$ ) at  $V_i = 2 \text{ mV}$ ;  $m = 0,3$ .

Fig.4 Sensitivity ( $V_i$ ), output voltage ( $V_o$ ) as a function of temperature behaviour ( $T_{amb}$ ). Measured at  $f_i = 1 \text{ MHz}$  in test circuit Fig.10.



RF/IF circuit for AM/FM radio

TEA5570

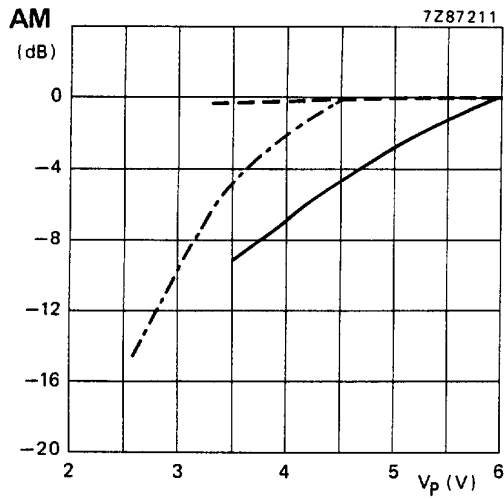

- sensitivity ( $V_i$ ) at  $V_o = 30$  V;  $m = 0,3$ ; 6,0 V application.
- - - - - sensitivity ( $V_i$ ) at  $V_o = 30$  mV;  $m = 0,3$ ; 4,5 V application.
- · · · · output voltage ( $V_o$ ) at  $V_i = 0,2$  mV;  $m = 0,3$ .

Fig.5 Sensitivity ( $V_i$ ) and output voltage ( $V_o$ ) as a function of supply voltage ( $V_p$ ). Measured at  $f_i = 1$  MHz in test circuit Fig.10, for application  $V_p = 6$  V. Also shown is the sensitivity for  $V_p = 4,5$  V application (Fig.16).

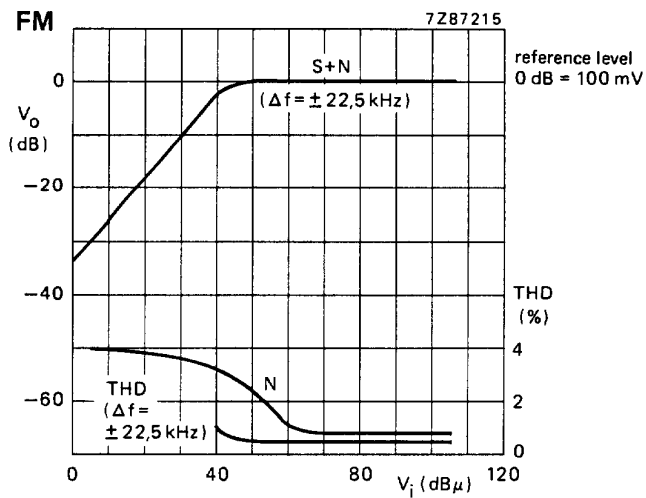
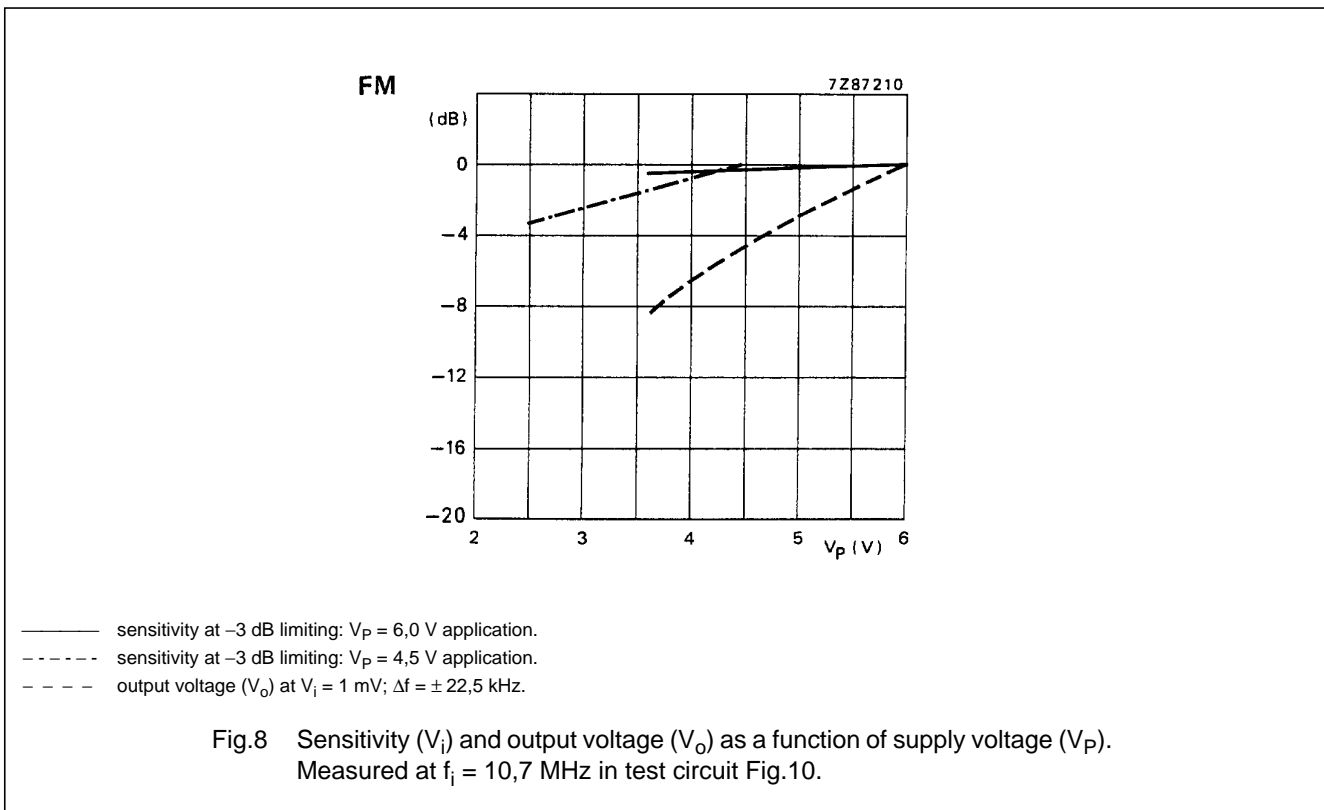
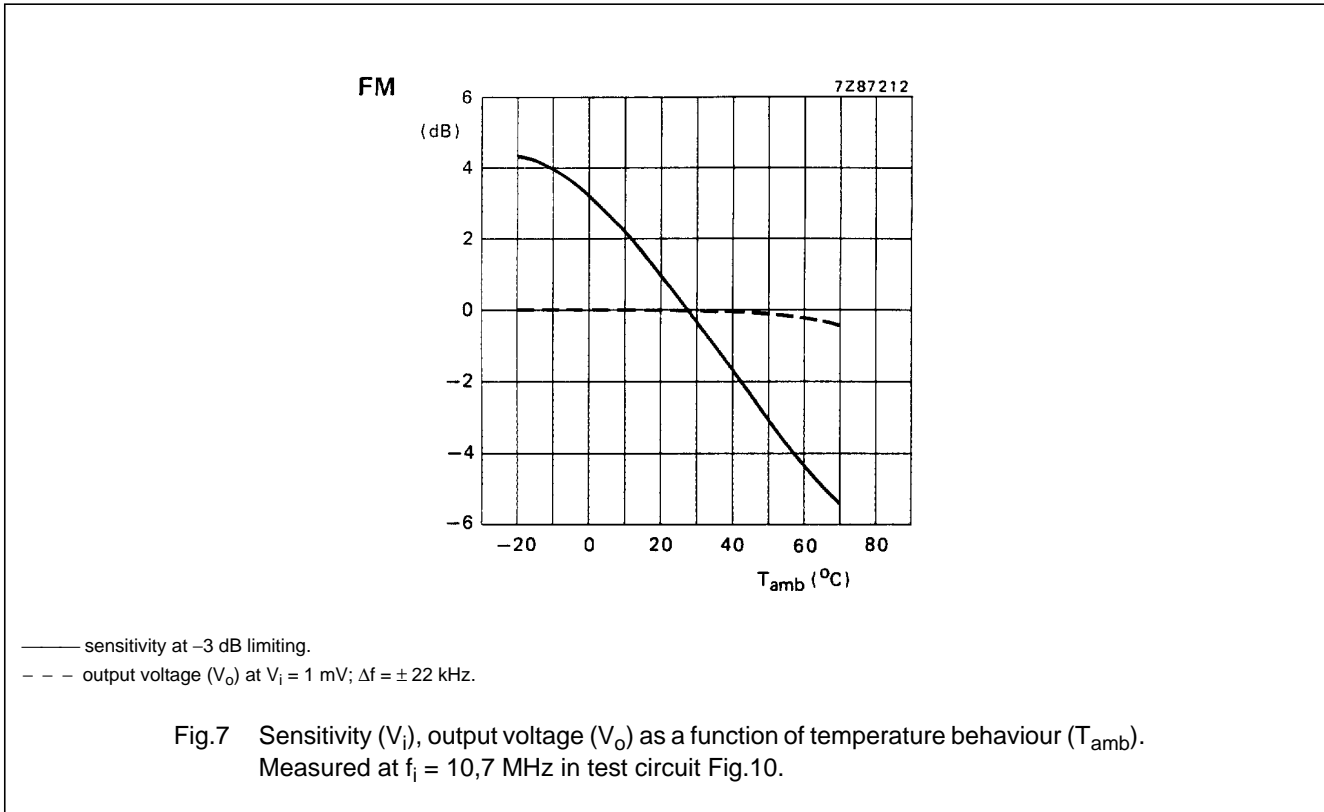

Fig.6 Signal, noise and distortion as a function of input voltage ( $V_i$ ). Measured at  $f_i = 10,7$  MHz in test circuit Fig.10.

RF/IF circuit for AM/FM radio

TEA5570



RF/IF circuit for AM/FM radio

TEA5570

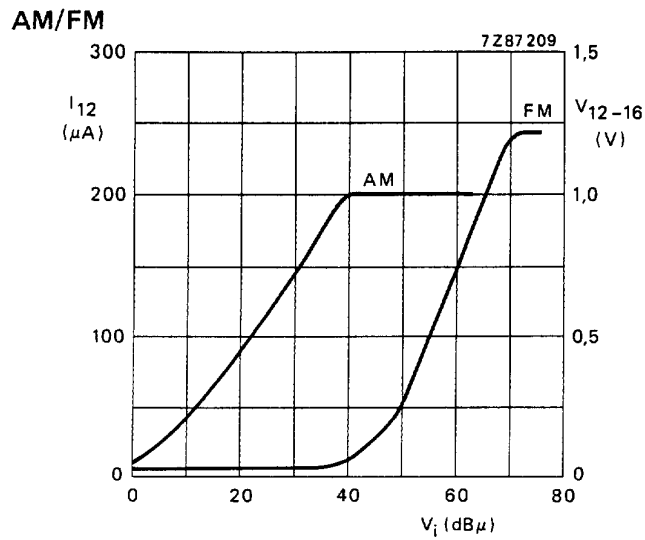

Fig.9 Indicator output current ( $I_{12}$ ) and d.c. output voltage ( $V_{12-16}$ ): AM  $f_i = 1$  MHz; FM  $f_i = 10,7$  MHz as a function of input voltage ( $V_i$ ). Measured in Fig.10;  $V_P = 6$  V;  $R_{12-16} = 5$  k $\Omega$ .

RF/IF circuit for AM/FM radio

TEA5570

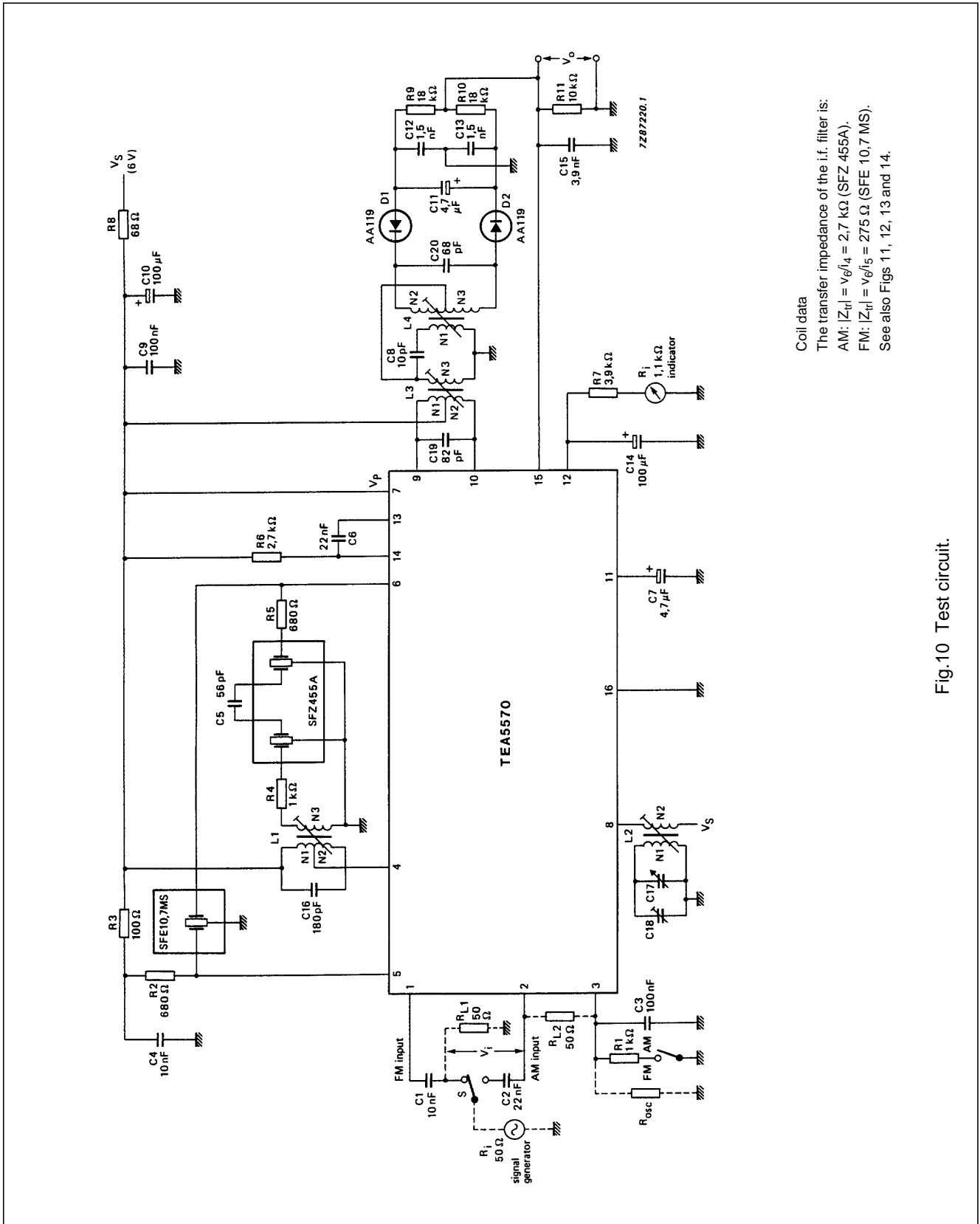

Fig.10 Test circuit.

RF/IF circuit for AM/FM radio

TEA5570

COIL DATA

AM i.f. coils (Fig.10)

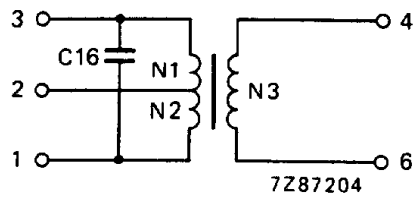

- N1 = 73
- N2 = 73
- N3 = 9
- C16 = 180 pF (internal)
- Wire = 0,07 mm dia.

Fig.11 I.F. bandpass filter (L1). TOKO sample no. 7 MC-7 P.

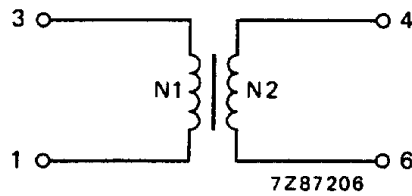

- N1 = 90
- N2 = 7
- Wire = 0,07 mm dia.

Fig.12 Oscillator coil (L2). TOKO sample no. 7 BR-7 P.

RF/IF circuit for AM/FM radio

TEA5570

FM i.f. coils (Fig.10)

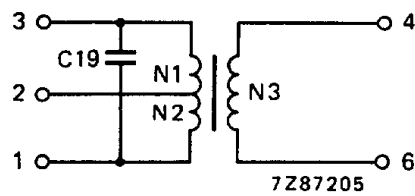

- N1 = 5
- N2 = 5
- N3 = 4
- C19 = 82 pF (internal)
- Wire = 0,1 mm dia.

Fig.13 Primary ratio detector coil (L3). TOKO sample no. 119 AN-7 P.

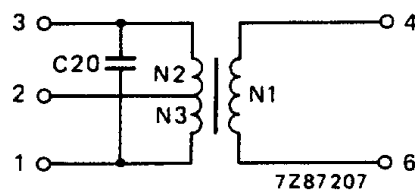

- N1 = 2
- N2 = 6
- N3 = 6
- C20 = 68 pF (internal)
- Wire = 0,1 mm dia.

Fig.14 Secondary ratio detector coil (L4). TOKO sample no. 119 AN-7 P.

RF/IF circuit for AM/FM radio

TEA5570

APPLICATION INFORMATION

Figs 15 and 17 show the circuit diagrams for the application of 6 V AM MW/LW and 4.5 V AM/FM channels respectively, using the TEA5570. Fig. 16 shows the circuitry of the TEA5570.

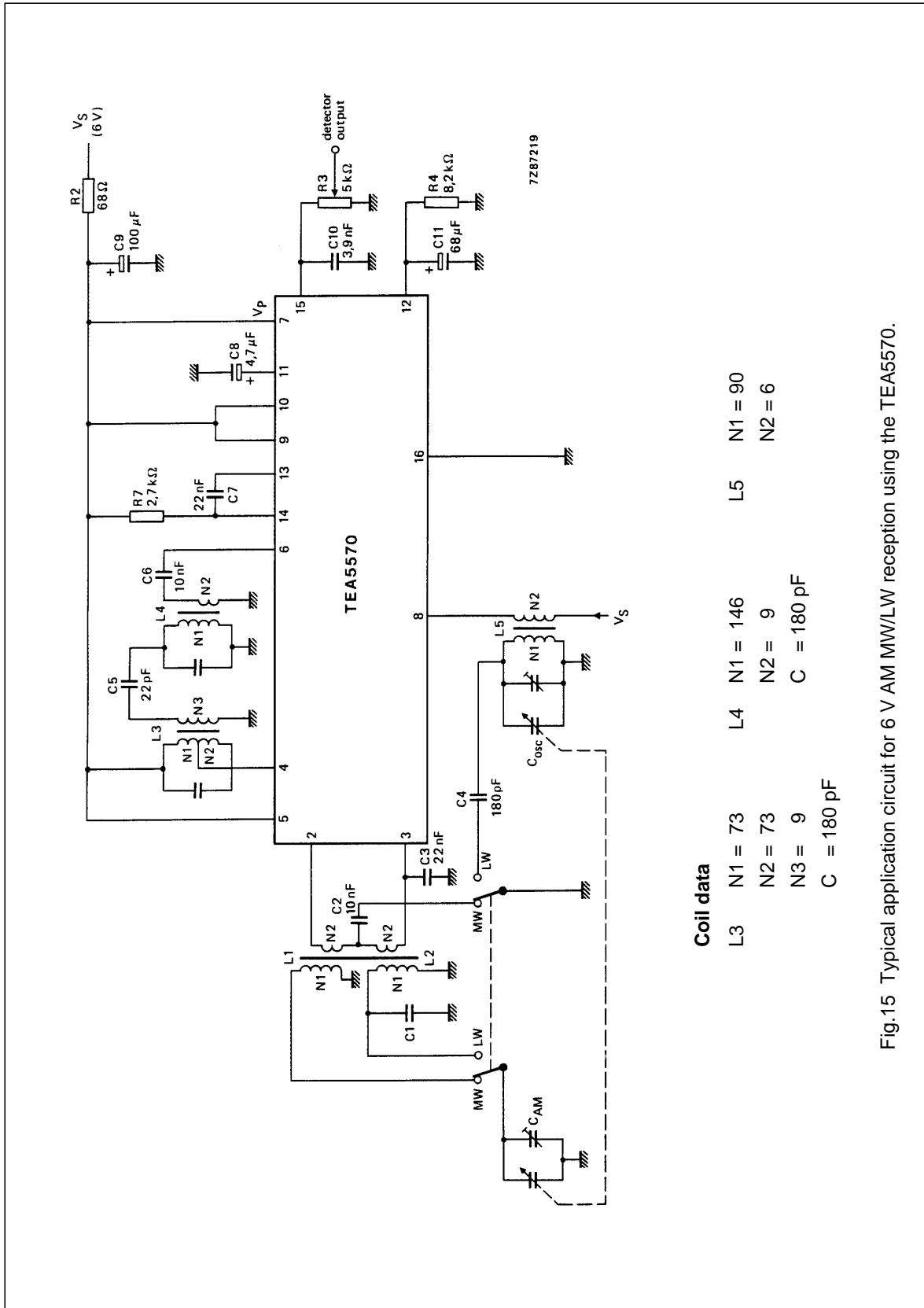

Coil data

|    |            |    |            |    |         |
|----|------------|----|------------|----|---------|
| L3 | N1 = 73    | L4 | N1 = 146   | L5 | N1 = 90 |
|    | N2 = 73    |    | N2 = 9     |    | N2 = 6  |
|    | N3 = 9     |    | C = 180 pF |    |         |
|    | C = 180 pF |    |            |    |         |

Fig.15 Typical application circuit for 6 V AM MW/LW reception using the TEA5570.

RF/IF circuit for AM/FM radio

TEA5570

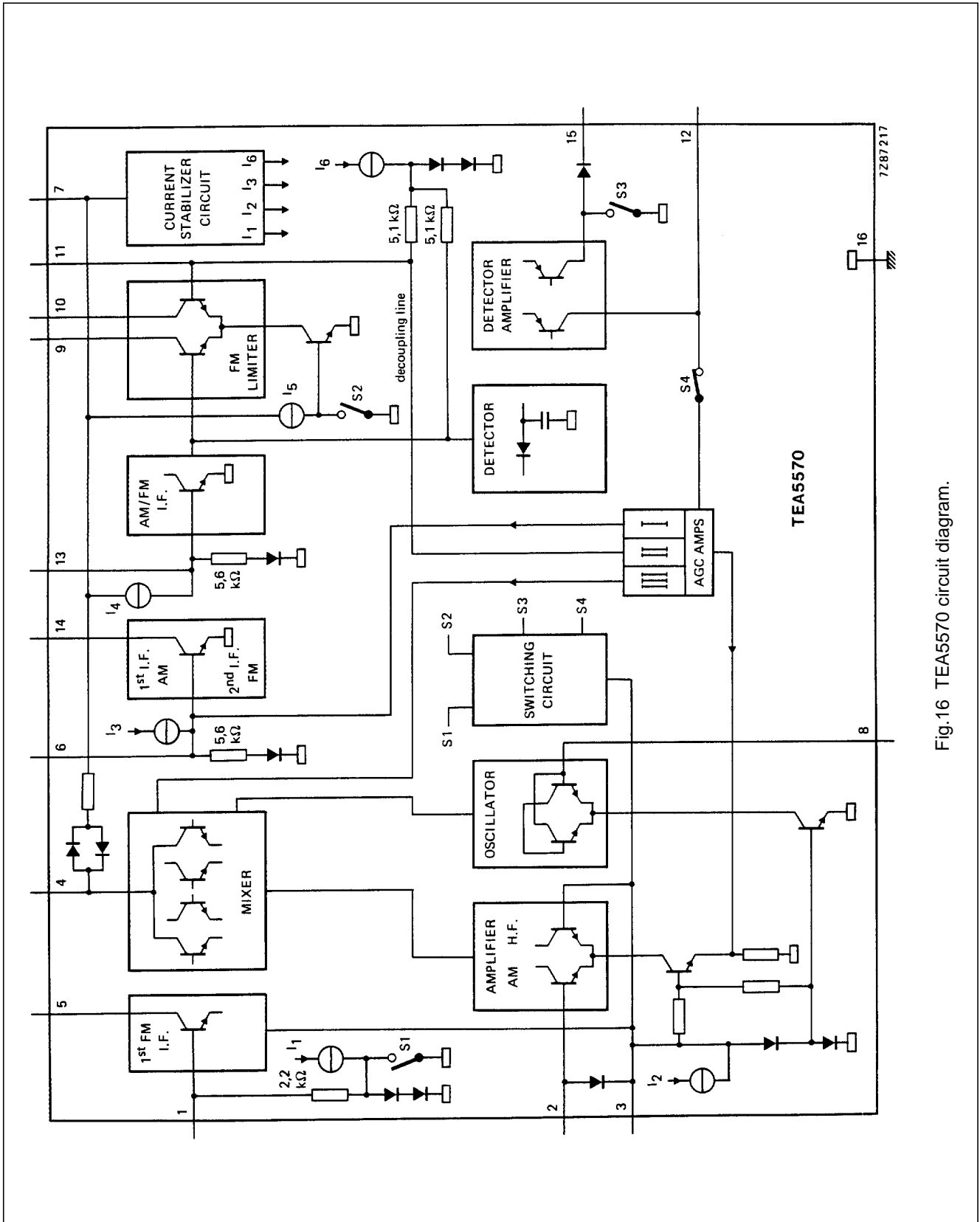

Fig.16 TEA5570 circuit diagram.



RF/IF circuit for AM/FM radio

TEA5570

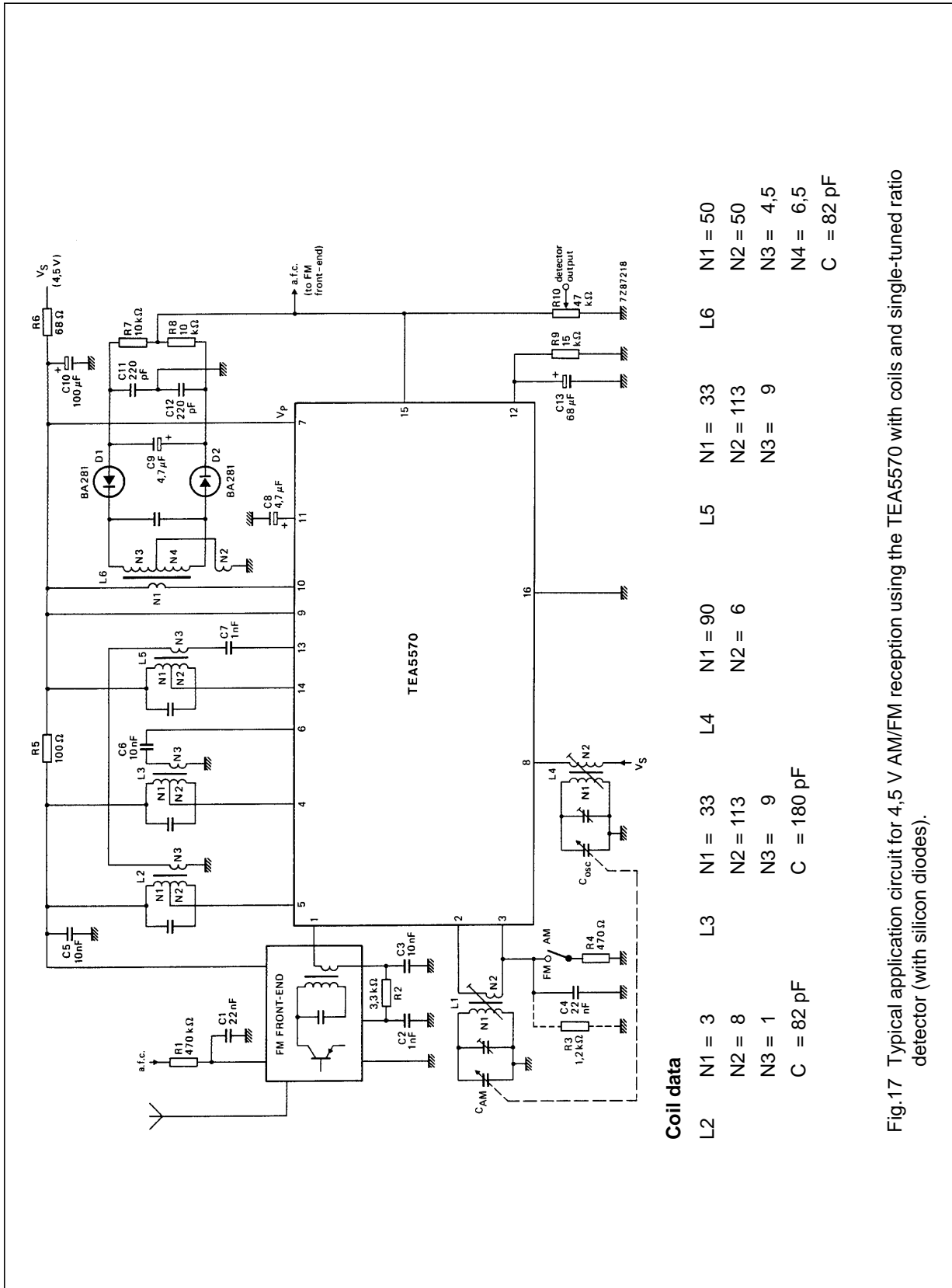

Fig. 17 Typical application circuit for 4.5 V AM/FM reception using the TEA5570 with coils and single-tuned ratio detector (with silicon diodes).

DETAILED APPLICATION INFORMATION WILL BE SUPPLIED ON REQUEST.

RF/IF circuit for AM/FM radio

TEA5570

PACKAGE OUTLINE

DIP16: plastic dual in-line package; 16 leads (300 mil); long body

SOT38-1

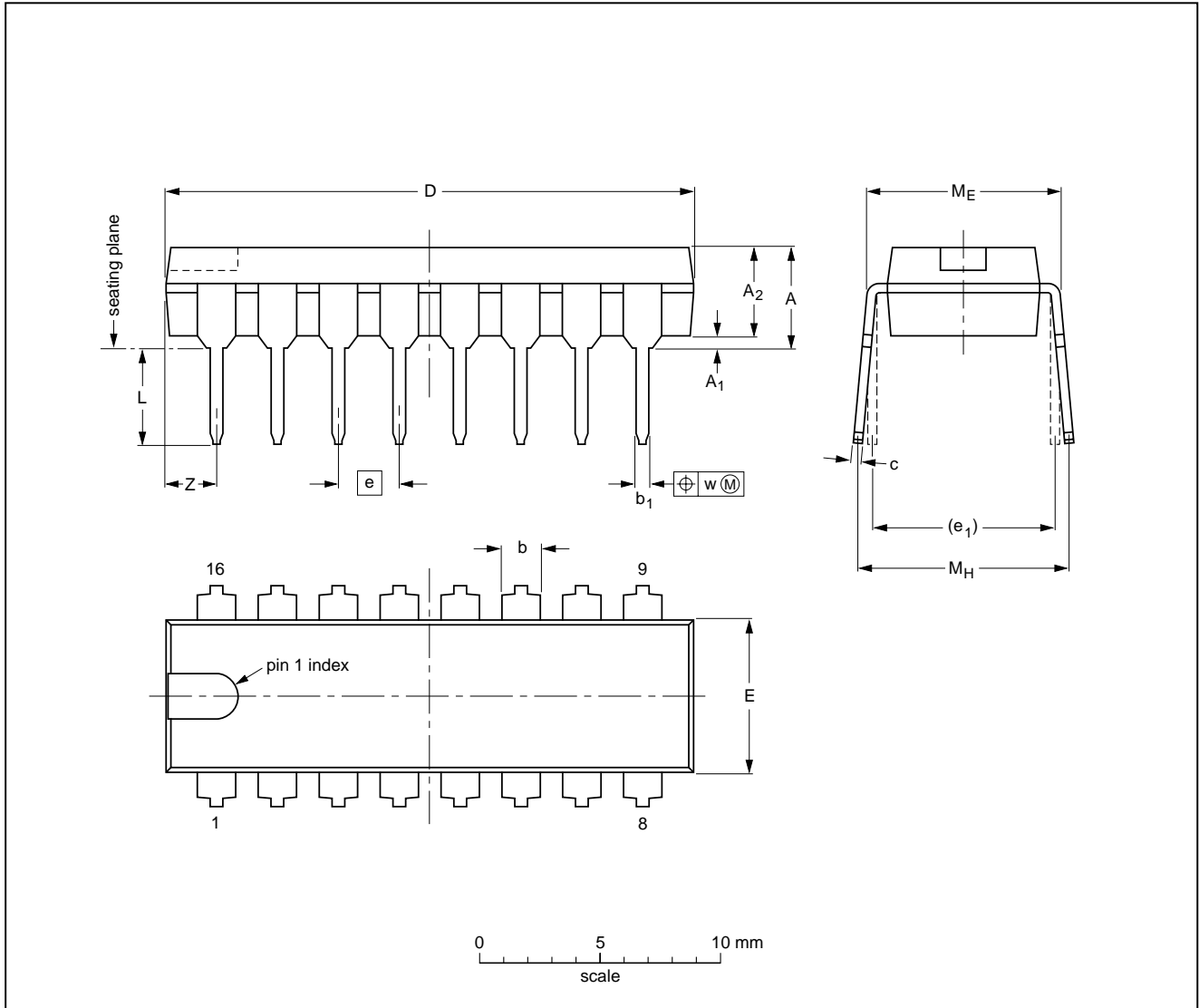

DIMENSIONS (inch dimensions are derived from the original mm dimensions)

| UNIT   | A max. | A <sub>1</sub> min. | A <sub>2</sub> max. | b              | b <sub>1</sub> | c              | D <sup>(1)</sup> | E <sup>(1)</sup> | e    | e <sub>1</sub> | L            | M <sub>E</sub> | M <sub>H</sub> | w     | z <sup>(1)</sup> max. |
|--------|--------|---------------------|---------------------|----------------|----------------|----------------|------------------|------------------|------|----------------|--------------|----------------|----------------|-------|-----------------------|
| mm     | 4.7    | 0.51                | 3.7                 | 1.40<br>1.14   | 0.53<br>0.38   | 0.32<br>0.23   | 21.8<br>21.4     | 6.48<br>6.20     | 2.54 | 7.62           | 3.9<br>3.4   | 8.25<br>7.80   | 9.5<br>8.3     | 0.254 | 2.2                   |
| inches | 0.19   | 0.020               | 0.15                | 0.055<br>0.045 | 0.021<br>0.015 | 0.013<br>0.009 | 0.86<br>0.84     | 0.26<br>0.24     | 0.10 | 0.30           | 0.15<br>0.13 | 0.32<br>0.31   | 0.37<br>0.33   | 0.01  | 0.087                 |

Note

1. Plastic or metal protrusions of 0.25 mm maximum per side are not included.

| OUTLINE VERSION | REFERENCES |          |      | EUROPEAN PROJECTION | ISSUE DATE           |
|-----------------|------------|----------|------|---------------------|----------------------|
|                 | IEC        | JEDEC    | EIAJ |                     |                      |
| SOT38-1         | 050G09     | MO-001AE |      |                     | 92-10-02<br>95-01-19 |

## RF/IF circuit for AM/FM radio

## TEA5570

**SOLDERING****Introduction**

There is no soldering method that is ideal for all IC packages. Wave soldering is often preferred when through-hole and surface mounted components are mixed on one printed-circuit board. However, wave soldering is not always suitable for surface mounted ICs, or for printed-circuits with high population densities. In these situations reflow soldering is often used.

This text gives a very brief insight to a complex technology. A more in-depth account of soldering ICs can be found in our "IC Package Databook" (order code 9398 652 90011).

**Soldering by dipping or by wave**

The maximum permissible temperature of the solder is 260 °C; solder at this temperature must not be in contact with the joint for more than 5 seconds. The total contact time of successive solder waves must not exceed 5 seconds.

The device may be mounted up to the seating plane, but the temperature of the plastic body must not exceed the specified maximum storage temperature ( $T_{stg\ max}$ ). If the printed-circuit board has been pre-heated, forced cooling may be necessary immediately after soldering to keep the temperature within the permissible limit.

**Repairing soldered joints**

Apply a low voltage soldering iron (less than 24 V) to the lead(s) of the package, below the seating plane or not more than 2 mm above it. If the temperature of the soldering iron bit is less than 300 °C it may remain in contact for up to 10 seconds. If the bit temperature is between 300 and 400 °C, contact may be up to 5 seconds.

**DEFINITIONS**

| <b>Data sheet status</b>  |   |
|---|---|
| Objective specification   | This data sheet contains target or goal specifications for product development.       |
| Preliminary specification   | This data sheet contains preliminary data; supplementary data may be published later. |
| Product specification   | This data sheet contains final product specifications.                                |
| <b>Limiting values</b>  |   |
| Limiting values given are in accordance with the Absolute Maximum Rating System (IEC 134). Stress above one or more of the limiting values may cause permanent damage to the device. These are stress ratings only and operation of the device at these or at any other conditions above those given in the Characteristics sections of the specification is not implied. Exposure to limiting values for extended periods may affect device reliability. |   |
| <b>Application information</b>  |   |
| Where application information is given, it is advisory and does not form part of the specification.   |   |

**LIFE SUPPORT APPLICATIONS**

These products are not designed for use in life support appliances, devices, or systems where malfunction of these products can reasonably be expected to result in personal injury. Philips customers using or selling these products for use in such applications do so at their own risk and agree to fully indemnify Philips for any damages resulting from such improper use or sale.