

PLL STEREO DECODER

GENERAL DESCRIPTION

The TEA5580 PLL stereo decoder is for car, portable and mains-fed medium-fi radios and radio recorders. It features a 228 kHz voltage-controlled oscillator (VCO) that is locked to the 19 kHz stereo pilot tone by a phase-locked loop (PLL) system. Subcarrier frequencies of 19, 38, 57 and 114 kHz are regenerated via I²L logic from the VCO output.

The PLL phase detector suppresses phase distortion due to the 57 kHz pilot tone from the German 'Verkehrs Warnfunk' (VWF) traffic warning system. Typical suppression of the 19 kHz stereo pilot tone is 50 dB, or up to 60 dB with adjustment of the pilot-cancelling resistor (R3, Figs 3 and 4). Adjacent channel interference is prevented by the use of two demodulators, one driven by the 38 kHz decoding signal and the other at 114 kHz to suppress the third harmonic of the multiplexed input signal.

The gain of the input amplifier can be adjusted by an external resistor and the circuit includes compensation for an IF filter typical roll-off frequency of 50 kHz (2 dB down at 38 kHz).

The supply voltage range of the circuit is 3,6 V to 16 V.

Features

- Wide supply voltage range
- Automatic mono/stereo switching (pilot presence detector)
- Smooth stereo-to-mono change-over at weak signals (signal-dependent stereo channel separation)
- LED driver for stereo/mono indicator
- Suppresses:
 - third harmonics (114 kHz) of multiplexed signal to prevent interference from strong adjacent channels;
 - phase distortion due to the 57 kHz signal from VWF transmitters
- Pilot cancelling circuit to give added suppression of 19 kHz pilot tone
- IF filter roll-off compensation



TEA5580

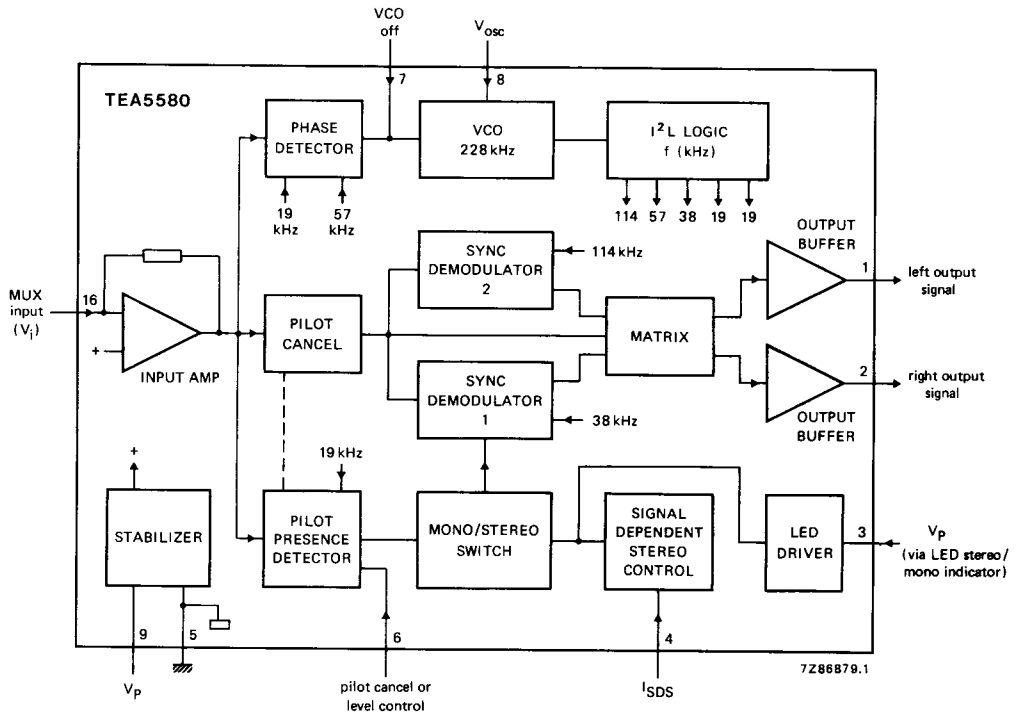

Fig. 1 Block diagram.

Note

Do not connect pins 10, 11, 12, 13, 14 or 15.

RATINGS

Limiting values in accordance with the Absolute Maximum System (IEC 134)

parameter	symbol	min.	max.	unit
Supply voltage (pins 3 and 9)	V_{3-5}, V_{9-5}	—	18	V
LED-driver current (peak value)	$-I_{3M}$	—	75	mA
Total power dissipation	P_{tot}	see derating curve Fig. 2		
Storage temperature range	T_{stg}	-55	+ 150	°C
Operating ambient temperature range	T_{amb}	-30	+ 80	°C

THERMAL RESISTANCE

From junction to ambient

$$R_{th\ j-a} = 75\ K/W$$

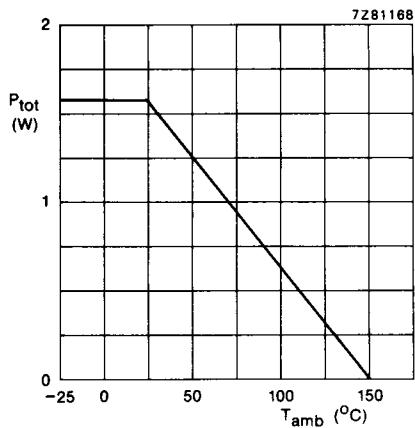

Fig. 2 Power derating curve.

CHARACTERISTICS

Measured in the circuit of Fig. 3; $V_P = 7,5 \text{ V}$; $T_{\text{amb}} = 25 \text{ }^\circ\text{C}$; all d.c. voltages are with respect to pin 5; all currents are positive into the IC; a.c. measurements have an input MUX-signal of 1 V (peak-to-peak); $V_{\text{pilot}} = 32 \text{ mV}$; $f_m = 1 \text{ kHz}$; de-emphasizing time = $50 \text{ } \mu\text{s}$; oscillator adjusted to I_{osc} at $V_i = 0 \text{ V}$; values are measured with an external roll-off network of 50 kHz (2 dB down at 38 kHz) at the input (dashed components R1 and C1 in Fig. 3); unless otherwise specified.

parameter	symbol	min.	typ.	max.	unit
D.C. Characteristics					
Supply voltage (note 1)	V_P	3,6	7,5	16	V
Total current consumption at $V_P = 7,5 \text{ V}$ (note 2)	I_P	–	10	13,5	mA
Dissipation at $V_P = 7,5 \text{ V}$ (note 2)	P_{tot}	–	75	–	mW
Bias voltage (pin 16)	V_{16-5}	–	1,4	–	V
Input current (pin 4)	I_4	–	–	400	μA
D.C. output current (pin 1)	$-I_1$	195	275	390	μA
D.C. output current (pin 2)	$-I_2$	195	275	390	μA
Output current (pin 3) (LED driver transistor)	$-I_3$	–	–	50	mA
Switch "VCO-OFF" voltage at pin 7	V_{off}	–	2,2	–	V
Switch "VCO-OFF" current into pin 7	I_7	–	–	50	μA
A.C. Characteristics					
Overall gain (mono)	$G_o (V_o/V_i)$	7	8	9,5	dB
Gain input amplifier (adjustable) (Fig. 5)	G	0	–	20	dB
AF output voltage (mono) (r.m.s. value)	$V_{1-5} = V_{2-5}$	800	900	–	mV
Output channel unbalance	$\Delta V_o/V_o$	–	$\pm 0,2$	$\pm 1,0$	dB
Total harmonic distortion at $V_o(\text{rms}) = 0,9 \text{ V}$ (note 3)	THD	–	0,2	0,5	%
Total harmonic distortion at $V_o(\text{rms}) = 1,0 \text{ V}$	THD	–	1,0	–	%
Channel separation $L = 1$; $R = 0$	α	26	40	–	dB
Signal-to-noise ratio bandwidth 20 Hz to 16 kHz	S/N	–	76	–	dB
Bandwidth IEC 79 (A-curve)	S/N	–	82	–	dB
Input impedance (external)	$ Z_i $	–	47	–	$\text{k}\Omega$
Output impedance (external) $R = 12 \text{ k}\Omega$; $C = 3,9 \text{ nF}$	$ Z_o $	–	9,3	–	$\text{k}\Omega$

parameter	symbol	min.	typ.	max.	unit
SDS control (Fig. 6)					
10 dB channel separation	I_4	—	50	—	μA
Full stereo channel separation > 26 dB	I_4	100	—	—	μA
Full mono channel separation < 1 dB	I_4	—	—	10	μA
Stereo/mono switch					
$R_3 = 180\text{ k}\Omega$; note 4; Fig. 7					
Switching to stereo	V_i	—	18	24	mV
Switching to mono	V_i	8	—	—	mV
Hysteresis	ΔV_i	—	4	—	mV
Carrier and harmonic suppression at the output (note 5)					
Pilot signal suppression $f = 19\text{ kHz}$; $R_3 = 180\text{ k}\Omega$; note 4; Fig. 4	α_{19}	40	50	—	dB
Subcarrier suppression $f = 38\text{ kHz}$	α_{38}	—	50	—	dB
$f = 57\text{ kHz}$	α_{57}	—	50	—	dB
$f = 228\text{ kHz}$	α_{228}	—	80	—	dB
Intermodulation suppression (note 6)					
$f_m = 10\text{ kHz}$; spurious signal $f_s = 1\text{ kHz}$	α_2	—	60	—	dB
$f_m = 13\text{ kHz}$; spurious signal $f_s = 1\text{ kHz}$	α_3	—	60	—	dB
VWF tone suppression $f = 57\text{ kHz}$ (note 7)	α_{57}	—	80	—	dB
SCA tone rejection $f = 67\text{ kHz}$ (note 8)	α_{67}	—	80	—	dB
ACI rejection (note 9)					
$f = 114\text{ kHz}$	α_{114}	—	90	—	dB
$f = 190\text{ kHz}$	α_{190}	—	60	—	dB

CHARACTERISTICS (continued)

parameter	symbol	min.	typ.	max.	unit
Ripple rejection					
f = 100 Hz; V _{ripple} = 200 mV; measured including RC network in supply line					
V _P = 7,5 V	RR ₁₀₀	—	42	—	dB
V _P = 6,0 V	RR ₁₀₀	—	46	—	dB
V _P = 3,6 V	RR ₁₀₀	—	35	—	dB
VCO					
Oscillator frequency adjustable with R8	f _{osc}	—	228	—	kHz
Capture range (deviation from 228 kHz centre frequency)					
V _{pilot} = 9% (note 10)	Δf/f	—	8	—	%
Temperature coefficient	TC	—	+ 400 × 10 ⁻⁶	—	K ⁻¹

Notes to the characteristics

- Minimum supply voltage only applicable in 6 V portable.
- Without LED-driver current.
- Guaranteed for mono, mono + pilot, stereo.
- Also adjustable.
- Reference output voltage at 1 kHz (measured channel R, pin 2).
- Intermodulation suppression (BFC: Beat-Frequency Components):

$$\alpha_2 = \frac{V_{O(\text{signal})} \text{ (at 1 kHz)}}{V_{O(\text{spurious})} \text{ (at 1 kHz)}}; f_s = (2 \times 10 \text{ kHz}) - 19 \text{ kHz}$$

$$\alpha_3 = \frac{V_{O(\text{signal})} \text{ (at 1 kHz)}}{V_{O(\text{spurious})} \text{ (at 1 kHz)}}; f_s = (3 \times 13 \text{ kHz}) - 38 \text{ kHz}$$

measured with 91% mono signal; f_m = 10 or 13 kHz; 9% pilot signal.

- Traffic radio (VWF) tone suppression:

$$\alpha_{57} = \frac{V_{O(\text{signal})} \text{ (at 1 kHz)}}{V_{O(\text{spurious})} \text{ (at 1 kHz} \pm 23 \text{ Hz)}}$$

measured with 91% stereo signal; f_m = 1 kHz; 9% pilot signal; 5% traffic subcarrier (f = 57 kHz; 60% AM modulated with f_{mod} = 23 Hz).

- SCA (Subsidiary Communication Authorization) tone rejection:

$$\alpha_{67} = \frac{V_{O(\text{signal})} \text{ (at 1 kHz)}}{V_{O(\text{spurious})} \text{ (at 9 kHz)}}; f_s = (2 \times 38 \text{ kHz}) - 67 \text{ kHz}$$

measured with 81% mono signal; f_m = 1 kHz; 9% pilot signal; 10% SCA-subcarrier (f_s = 67 kHz, unmodulated).

9. ACI (Adjacent Channel Interference) rejection at:

$$\alpha_{114} = \frac{V_{o(\text{signal})} \text{ (at 1 kHz)}}{V_{o(\text{spurious})} \text{ (at 4 kHz)}} ; f_s = (3 \times 38 \text{ kHz}) - 110 \text{ kHz}$$

$$\alpha_{190} = \frac{V_{o(\text{signal})} \text{ (at 1 kHz)}}{V_{o(\text{spurious})} \text{ (at 4 kHz)}} ; f_s = (5 \times 38 \text{ kHz}) - 186 \text{ kHz}$$

measured with 90% mono signal; $f_s = 1 \text{ kHz}$; 9% pilot signal; 1% spurious signal ($f_s = 110$ or 186 kHz , unmodulated).

10. The capture range of the PLL may be decreased to 4% by changing the value of C2 to 470 nF (see Fig. 4), if a small ambient temperature range is provided.

Notes to Figs 3 and 4

- (1) R4: VCO frequency adjustment (228 kHz).
- (2) R3: pilot cancelling or pilot level adjustment; best adjustment obtained with 470 kΩ potentiometer (see Figs 7 and 8); adjust for pilot cancellation of approx. 58 dB ± 10 dB and pilot sensitivity (mono to stereo) of approx. 23 mV ± 3 mV.

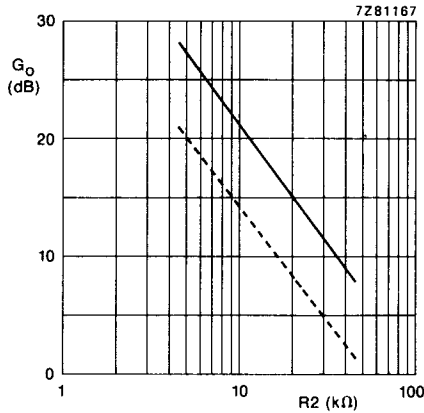

— R5 = R6 = 12 kΩ
 - - - R5 = R6 = 5,1 kΩ

Fig. 5 Overall gain as a function of input resistance (R2).

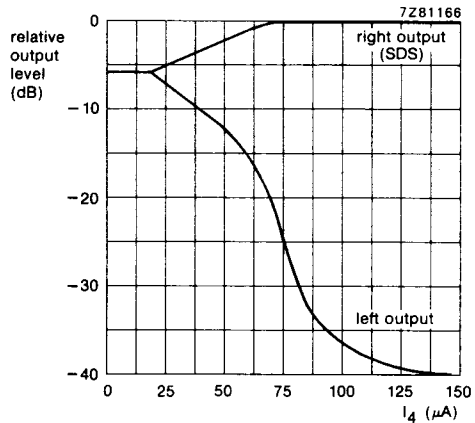
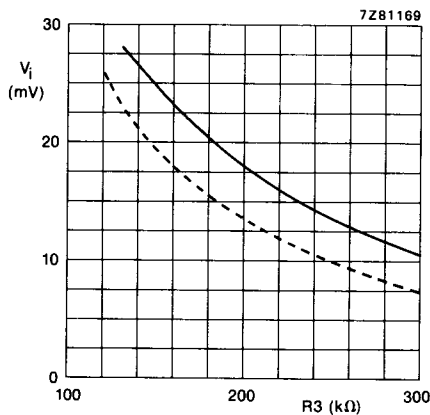

Fig. 6 Relative output level as a function of the signal dependent stereo (SDS) current (I_4); typical curves.



— stereo "ON"
 - - - stereo "OFF"

Fig. 7 Pilot sensitivity: pilot input voltage (V_i) as a function of pilot adjustment resistor R3; typical curves.

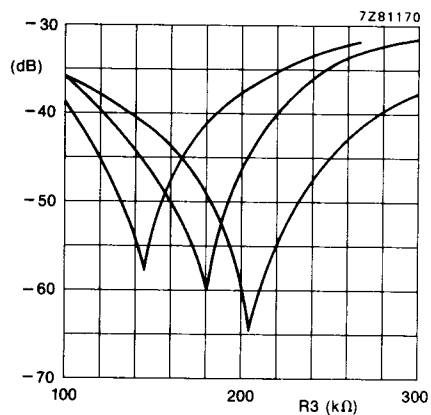

Fig. 8 Random samples of pilot cancelling: V_O (at 19 kHz) / V_O (at 1 kHz) in dB as a function of R3; $V_{i(p-p)} = 1 V$; $V_{pilot} = 32 mV$ (9%).