

INTEGRATED CIRCUITS

DATA SHEET

TEA6324T Sound control circuit

Preliminary specification
File under Integrated Circuits, IC01

1997 Mar 13

Sound control circuit

TEA6324T

FEATURES

- Source selector for two stereo and one mono inputs
- Interface for noise reduction circuits
- Interface for external equalizer
- Volume and balance control
- Bass control with equalizer filters
- Treble control
- Mute control at audio signal zero crossing
- Fast mute control via I²C-bus
- Fast mute control via pin
- I²C-bus control for all functions
- Power supply with internal power-on reset.



GENERAL DESCRIPTION

The sound control circuit TEA6324T is an I²C-bus controlled stereo preamplifier for car radio hi-fi sound applications.

QUICK REFERENCE DATA

SYMBOL	PARAMETER	CONDITIONS	MIN.	TYP.	MAX.	UNIT
V _{CC}	supply voltage		7.5	8.5	9.5	V
I _{CC}	supply current	V _{CC} = 8.5 V	–	26	–	mA
V _{o(rms)}	maximum output voltage level	V _{CC} = 8.5 V; THD ≤ 0.1%	–	2000	–	mV
G _v	voltage gain		–86	–	+20	dB
G _{step(vol)}	step resolution (volume)		–	1	–	dB
G _{bass}	bass control		–18	–	+18	dB
G _{treble}	treble control		–12	–	+12	dB
G _{step(treble)}	step resolution (treble)		–	1.5	–	dB
(S+N)/N	signal-plus-noise to noise ratio	V _o = 2.0 V; G _v = 0 dB; unweighted	–	105	–	dB
RR ₁₀₀	ripple rejection	V _{r(rms)} < 200 mV; f = 100 Hz; G _v = 0 dB	–	75	–	dB
α _{cs}	channel separation	250 Hz ≤ f ≤ 10 kHz; G _v = 0 dB	90	96	–	dB

ORDERING INFORMATION

TYPE NUMBER	PACKAGE		
	NAME	DESCRIPTION	VERSION
TEA6324T	SO24	plastic small outline package; 24 leads; body width 7.5 mm	SOT137-1

Sound control circuit

TEA6324T

BLOCK DIAGRAM

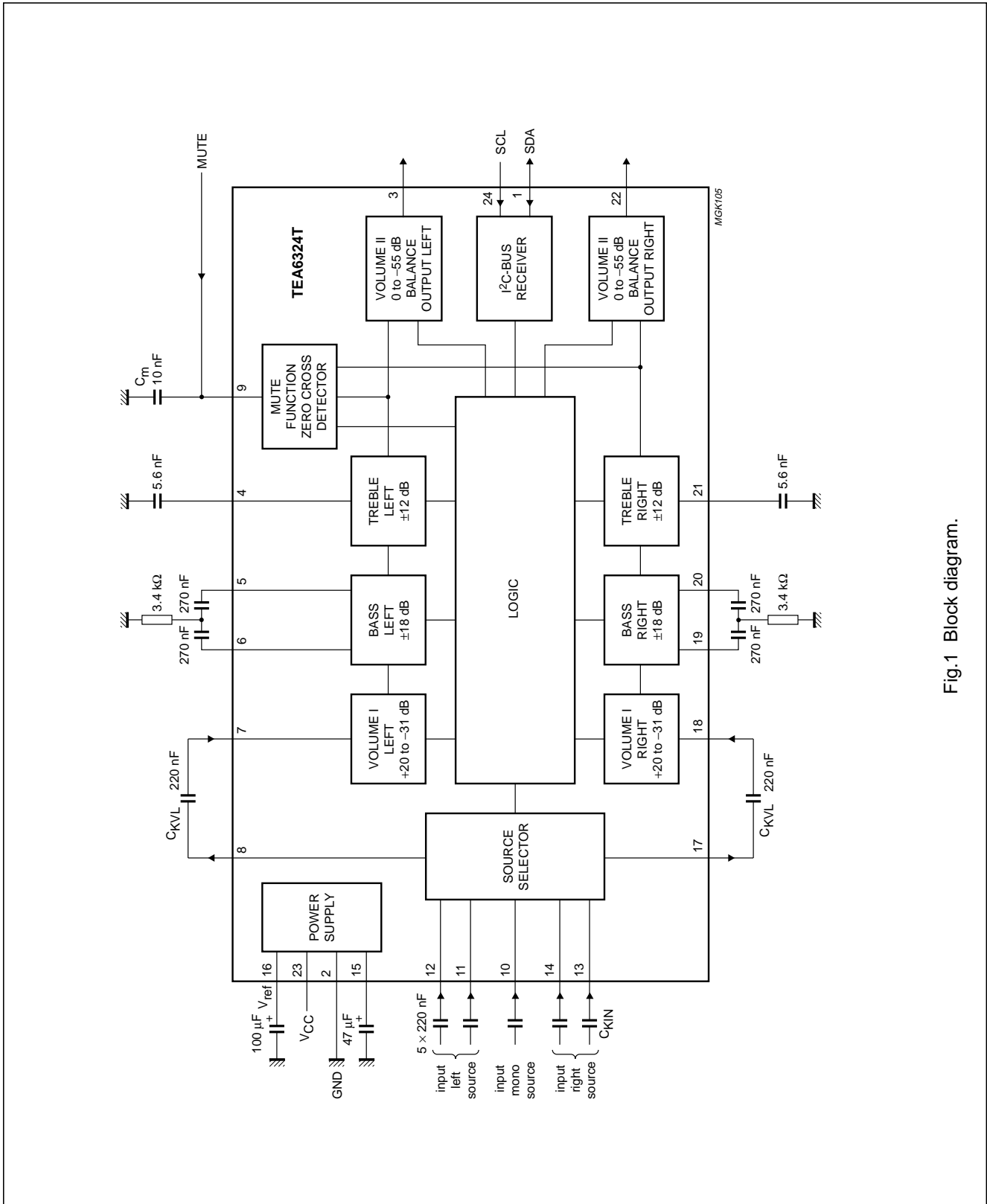

Fig.1 Block diagram.

Sound control circuit

TEA6324T

PINNING

SYMBOL	PIN	DESCRIPTION
SDA	1	serial data input/output (I ² C-bus)
GND	2	ground
OUTL	3	output left
TL	4	treble control capacitor left channel or input from an external equalizer
B2L	5	bass control left channel or output to an external equalizer
B1L	6	bass control, left channel
IVL	7	input volume I, left control part
QSL	8	output source selector, left channel
MUTE	9	mute control
IMO	10	input mono source
IBL	11	input B left source
IAL	12	input A left source
IAR	13	input A right source
IBR	14	input B right source
CAP	15	electronic filtering for supply
V _{ref}	16	reference voltage (0.5V _{CC})
QSR	17	output source selector right channel
IVR	18	input volume I, right control part
B1R	19	bass control right channel
B2R	20	bass control right channel or output to an external equalizer
TR	21	treble control capacitor right channel or input from an external equalizer
OUTR	22	output right
V _{CC}	23	supply voltage
SCL	24	serial clock input (I ² C-bus)

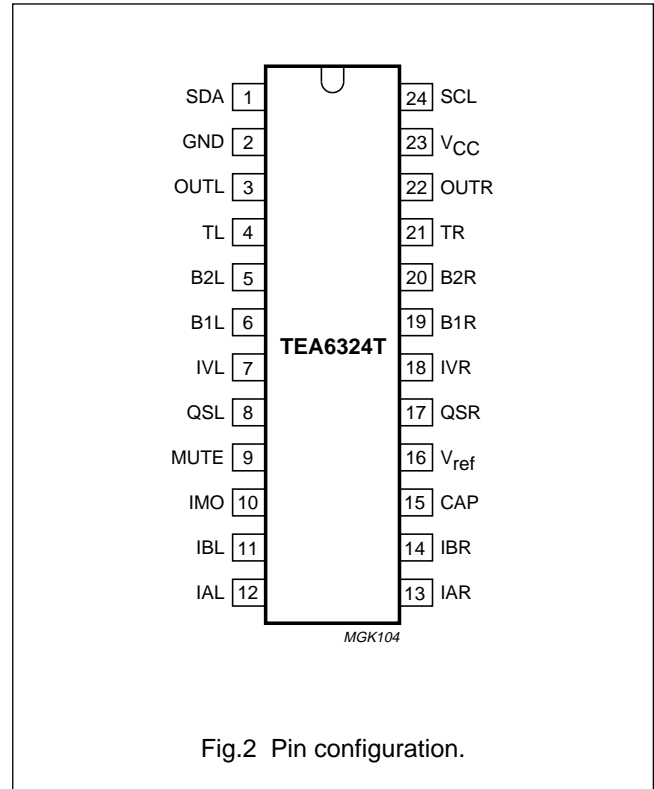

Fig.2 Pin configuration.

Sound control circuit

TEA6324T

FUNCTIONAL DESCRIPTION

The source selector selects one of 2 stereo inputs or the mono input. The maximum input signal voltage is $V_{i(rms)} = 2\text{ V}$. The outputs of the source selector and the inputs of the following volume control parts are available at pins 7 and 8 for the left channel and pins 17 and 18 for the right channel. This offers the possibility of interfacing a noise reduction system.

The volume control function is split into two sections: volume I control block and volume II control block.

The control range of volume I is between +20 dB and -31 dB in steps of 1 dB. The volume II control range is between 0 dB and -55 dB in steps of 1 dB.

The recommended control range to be used is 86 dB (+20 to -66 dB) although in theory, a range of 106 dB (+20 to -86 dB) can be attained. The gain/attenuation setting of the volume I control block is common for both channels.

The volume I control block is followed by the bass control block. The frequency response of the bass control (see Fig.3) is provided for each channel by an external filter in combination with internal resistors. The adjustable range is between -18 and +18 dB in steps of 1.8 dB at 46 Hz.

The treble control block offers a control range between -12 and +12 dB in steps of 1.5 dB at 15 kHz. The filter characteristic is determined by a single capacitor of 5.6 nF for each channel in combination with internal resistors (see Fig.4).

The basic step width of treble control is 3 dB.

The intermediate steps are obtained by switching 1.5 dB boost and 1.5 dB attenuation steps.

The bass and treble control functions can be switched off via I²C-bus. In this event the internal signal flow is disconnected. The connections B2L and B2R are outputs and TL and TR are inputs for inserting an external equalizer.

The last section of the circuit is the volume II block.

The balance function uses the same control block. This is achieved by 2 independently controllable attenuators, one for each output. The control range of these attenuators is 55 dB in steps of 1 dB with an additional mute step.

The circuit provides 3 mute modes:

1. Zero crossing mode mute via I²C-bus using 2 independent zero crossing detectors (ZCM, see Tables 2 and 8 and Fig.15)
2. Fast mute via MUTE pin (see Fig.9)

3. Fast mute via I²C-bus either by general mute (GMU, see Tables 2 and 8) or volume II block setting (see Table 4).

The mute function is performed immediately if ZCM is cleared (ZCM = 0). If the bit is set (ZCM = 1) the mute is activated after changing the GMU bit. The actual mute switching is delayed until the next zero crossing of the audio frequency signal. Two comparators are built-in to provide independent mute switches to control each of the audio channels (left and right).

To avoid a large delay of mute switching when very low frequencies are processed, the maximum delay time is limited to typically 100 ms by an integrated timing circuit and an external capacitor ($C_m = 10\text{ nF}$, see Fig.9). This timing circuit is triggered by reception of a new data word for the switch function which includes the GMU bit. After a discharge and charge period of an external capacitor the muting switch follows the GMU bit, only if no zero crossing was detected during that time.

The mute function can also be controlled externally (see Fig.9). If the mute pin is switched to ground all outputs are muted immediately (hardware mute). This mute request overwrites all mute controls via the I²C-bus for the time the pin is held LOW. The hardware mute position is not stored in the TEA6324T.

Typically, the turn on/off can be used to avoid AF output. This can be caused by the input signal from preceding stages, which may produce output during a drop of V_{CC} . To avoid this, the mute must be set prior to a V_{CC} drop and can be achieved either by I²C-bus control, or by grounding the MUTE pin.

In cases where there is no mute in the application before turn off, a supply voltage drop of more than $1 \times V_{BE}$ will result in a mute during the voltage drop.

The power supply should include a V_{CC} buffer capacitor, which provides a discharging time constant. If the input signal does not disappear after turn off the input will become audible after a certain time. A 4.7 k Ω resistor discharges the V_{CC} buffer capacitor, because the internal current of the IC does not discharge it completely.

The hardware mute function is ideal for use in Radio Data System (RDS) applications. The zero crossing mute avoids modulation plops. This feature is an advantage for mute during changing presets and/or sources (e.g. traffic announcement during cassette playback).

Sound control circuit

TEA6324T

LIMITING VALUES

In accordance with the Absolute Maximum Rating System (IEC 134).

SYMBOL	PARAMETER	CONDITIONS	MIN.	MAX.	UNIT
V _{CC}	supply voltage		0	10	V
V _n	voltage at all pins relative to pin 2		0	V _{CC}	V
T _{amb}	operating ambient temperature		-40	+85	°C
T _{stg}	storage temperature		-65	+150	°C
V _{es}	electrostatic handling	note 1	-	-	

Note

1. Human body model: C = 100 pF; R = 1.5 kΩ; V ≥ 2 kV. Machine model: C = 200 pF; R = 0 Ω; V ≥ 500 V.

Sound control circuit

TEA6324T

CHARACTERISTICS

$V_{CC} = 8.5\text{ V}$; $R_S = 600\ \Omega$; $R_L = 10\ \text{k}\Omega$; $C_L = 2.5\ \text{nF}$; AC coupled; $f = 1\ \text{kHz}$; $T_{\text{amb}} = 25\ ^\circ\text{C}$; gain control $G_V = 0\ \text{dB}$; bass linear; treble linear; balance in mid position; unless otherwise specified.

SYMBOL	PARAMETER	CONDITIONS	MIN.	TYP.	MAX.	UNIT
V_{CC}	supply voltage		7.5	8.5	9.5	V
I_{CC}	supply current		–	26	33	mA
V_{DC}	internal DC voltage at inputs and outputs		3.83	4.25	4.68	V
V_{ref}	internal reference voltage at pin 16		–	4.25	–	V
$G_{V(\text{max})}$	maximum voltage gain	$R_S = 0\ \Omega$; $R_L = \infty$	19	20	21	dB
$V_{o(\text{rms})}$	output voltage level (RMS value) for P_{max} at the power output stage start of clipping	THD $\leq 0.1\%$; see Fig.10	–	2000	–	mV
		THD = 1%	2300	–	–	mV
		$R_L = 2\ \text{k}\Omega$; $C_L = 10\ \text{nF}$; THD = 1%	2000	–	–	mV
$V_{i(\text{rms})}$	input sensitivity	$V_o = 2000\ \text{mV}$; $G_V = 20\ \text{dB}$	–	200	–	mV
f_{ro}	roll-off frequency	$C_{KIN} = 220\ \text{nF}$; $C_{KVL} = 220\ \text{nF}$; $Z_i = Z_{i(\text{min})}$ low frequency (–1 dB)	60	–	–	Hz
		low frequency (–3 dB)	30	–	–	Hz
		high frequency (–1 dB)	20000	–	–	Hz
		$C_{KIN} = 470\ \text{nF}$; $C_{KVL} = 100\ \text{nF}$; $Z_i = Z_{i(\text{typ})}$ low frequency (–3 dB)	17	–	–	Hz
α_{cs}	channel separation	$V_i = 2\ \text{V}$; frequency range 250 Hz to 10 kHz	90	96	–	dB
THD	total harmonic distortion	frequency range 20 Hz to 12.5 kHz				
		$V_i = 100\ \text{mV}$; $G_V = 20\ \text{dB}$	–	0.1	–	%
		$V_i = 1\ \text{V}$; $G_V = 0\ \text{dB}$	–	0.05	0.15	%
		$V_i = 2\ \text{V}$; $G_V = 0\ \text{dB}$	–	0.1	–	%
RR	ripple rejection	$V_{r(\text{rms})} < 200\ \text{mV}$ $f = 100\ \text{Hz}$	70	76	–	dB
		$f = 40\ \text{Hz}$ to 12.5 kHz	–	66	–	dB
(S+N)/N	signal-plus-noise to noise ratio	unweighted; 20 Hz to 20 kHz RMS; $V_o = 2.0\ \text{V}$; see Figs 5 and 6	–	105	–	dB
		CCIR468-2 weighted; quasi peak; $V_o = 2.0\ \text{V}$				
		$G_V = 0\ \text{dB}$	–	95	–	dB
		$G_V = 12\ \text{dB}$	–	88	–	dB
		$G_V = 20\ \text{dB}$	–	81	–	dB

Sound control circuit

TEA6324T

SYMBOL	PARAMETER	CONDITIONS	MIN.	TYP.	MAX.	UNIT
$P_{no(rms)}$	noise output power (RMS value) only contribution of TEA6324T; power amplifier for 6 W	mute position; note 1	–	–	10	nW
α_{ct}	crosstalk between bus inputs and signal outputs $\left(20 \log \frac{V_{bus(p-p)}}{V_{o(rms)}} \right)$	note 2	–	110	–	dB
Source selector						
Z_i	input impedance		25	35	45	k Ω
α_S	input isolation of one selected source to any other input	f = 1 kHz	–	105	–	dB
		f = 12.5 kHz	–	95	–	dB
$V_{i(rms)}$	maximum input voltage (RMS value)	THD < 0.5%; $V_{CC} = 8.5$ V	–	2.15	–	V
		THD < 0.5%; $V_{CC} = 7.5$ V	–	1.8	–	V
V_{offset}	DC offset voltage at source selector output by selection of any inputs		–	–	10	mV
Z_o	output impedance		–	80	120	Ω
R_L	output load resistance		10	–	–	k Ω
C_L	output load capacity		0	–	2500	pF
G_v	voltage gain, source selector		–	0	–	dB
Control part (source selector disconnected; source resistance 600 Ω)						
Z_i	input impedance volume input		100	150	200	k Ω
Z_o	output impedance		–	80	120	Ω
R_L	output load resistance		2	–	–	k Ω
C_L	output load capacity		0	–	10	nF
R_{DCL}	DC load resistance at output to ground		4.7	–	–	k Ω
$V_{i(rms)}$	maximum input voltage (RMS value)	THD < 0.5%	–	2.15	–	V
$V_{n(o)}$	noise output voltage	CCIR468-2 weighted; quasi peak				
		$G_v = 20$ dB	–	110	220	μ V
		$G_v = 0$ dB	–	33	50	μ V
		$G_v = -66$ dB	–	13	22	μ V
		mute position	–	10	–	μ V
CR_{tot}	total continuous control range		–	106	–	dB
	recommended control range		–	86	–	dB
G_{step}	step resolution		–	1	–	dB
	step error between any adjoining step		–	–	0.5	dB
ΔG_a	attenuator set error	$G_v = +20$ to -50 dB	–	–	2	dB
		$G_v = -51$ to -66 dB	–	–	3	dB
ΔG_t	gain tracking error	$G_v = +20$ to -50 dB	–	–	2	dB
α_{mute}	mute attenuation	see Fig.9	100	110	–	dB

Sound control circuit

TEA6324T

SYMBOL	PARAMETER	CONDITIONS	MIN.	TYP.	MAX.	UNIT
V_{offset}	DC step offset between any adjoining step	$G_V = 0$ to -66 dB	–	0.2	10	mV
		$G_V = 20$ to 0 dB	–	2	15	mV
	DC step offset between any step to mute	$G_V = 0$ to -66 dB	–	–	10	mV
Volume I control						
$CR_{\text{tot(vol)1}}$	continuous volume control range		–	51	–	dB
G_V	voltage gain		-31	–	$+20$	dB
G_{step}	step resolution		–	1	–	dB
Bass control						
G_{bass}	bass control, maximum boost	$f = 46$ Hz	16	18	19	dB
	maximum attenuation	$f = 46$ Hz	16	18	19	dB
G_{step}	step resolution (toggle switching)	$f = 46$ Hz	–	1.8	–	dB
	step error between any adjoining step	$f = 46$ Hz	–	–	0.5	dB
V_{offset}	DC step offset in any bass position		–	–	25	mV
Treble control						
G_{treble}	treble control, maximum boost	$f = 15$ kHz	11	12	13	dB
	maximum attenuation	$f = 15$ kHz	11	12	13	dB
	maximum boost	$f > 15$ kHz	–	–	15	dB
G_{step}	step resolution (toggle switching)	$f = 15$ kHz	–	1.5	–	dB
	step error between any adjoining step	$f = 15$ kHz	–	–	0.5	dB
V_{offset}	DC step offset in any treble position		–	–	10	mV
Volume II and balance control						
$CR_{\text{tot(vol)2}}$	continuous attenuation of volume control range		53.5	55	56.5	dB
G_{step}	step resolution		–	1	2	dB
	attenuation set error		–	–	1.5	dB
Mute function (see Fig.9)						
HARDWARE MUTE						
V_{sw}	mute switch level ($2 \times V_{\text{BE}}$)		–	1.45	–	V
<i>mute active</i>						
V_{swLOW}	input level		–	–	1.0	V
I_i	input current	$V_{\text{swLOW}} = 1$ V	-300	–	–	μA
<i>mute passive: level internally defined</i>						
V_{swHIGH}	saturation voltage		–	–	V_{CC}	V
$t_{\text{d(mute)}}$	delay until mute passive		–	–	0.5	ms
ZERO CROSSING MUTE						
I_{dch}	discharge current		0.3	0.6	1.2	μA
I_{ch}	charge current		-300	-150	–	μA
V_{swDEL}	delay switch level ($3 \times V_{\text{BE}}$)		–	2.2	–	V

Sound control circuit

TEA6324T

SYMBOL	PARAMETER	CONDITIONS	MIN.	TYP.	MAX.	UNIT
t_d	delay time	$C_m = 10 \text{ nF}$	–	100	–	ms
$V_{(w)}$	window for audio signal zero crossing detection		–	30	40	mV
Muting at power supply drop						
V_{CCdrop}	supply drop for mute active		–	$V_{23} - 0.7$	–	V
Power-on reset when reset is active the GMU-bit (general mute) is set and the I²C-bus receiver is in reset position						
V_{CC}	increasing supply voltage start of reset		–	–	2.5	V
	end of reset		5.2	6.5	7.2	V
	decreasing supply voltage start of reset		4.2	5.5	6.2	V
Digital part (I²C-bus pins); note 3						
V_{IH}	HIGH-level input voltage		3	–	9.5	V
V_{IL}	LOW-level input voltage		–0.3	–	+1.5	V
I_{IH}	HIGH-level input current		–10	–	+10	μA
I_{IL}	LOW-level input current		–10	–	+10	μA
V_{OL}	LOW-level output voltage	$I_L = 3 \text{ mA}$	–	–	0.4	V

Notes to the characteristics

1. The indicated values for output power assume a 6 W power amplifier at 4 Ω with 20 dB gain and a fixed attenuator of 12 dB in front of it. Signal-to-noise ratios exclude noise contribution of the power amplifier.
2. The transmission contains: total initialization with MAD and subaddress for volume and 8 data words, see also definition of characteristics, clock frequency = 50 kHz, repetition burst rate = 400 Hz, maximum bus signal amplitude = 5 V (p-p).
3. The AC characteristics are in accordance with the I²C-bus specification. This specification, "*The I²C-bus and how to use it*", can be ordered using the code 9398 393 40011.

Sound control circuit

TEA6324T

I²C-BUS PROTOCOL**I²C-bus format**

S ⁽¹⁾	SLAVE ADDRESS ⁽²⁾	A ⁽³⁾	SUBADDRESS ⁽⁴⁾	A ⁽³⁾	DATA ⁽⁵⁾	A ⁽³⁾	P ⁽⁶⁾
------------------	------------------------------	------------------	---------------------------	------------------	---------------------	------------------	------------------

Notes

1. S = START condition.
2. SLAVE ADDRESS (MAD) = 0101 0000.
3. A = acknowledge, generated by the slave.
4. SUBADDRESS (SAD), see Table 1.
5. DATA, see Table 1.
6. P = STOP condition.

Table 1 Second byte after MAD

FUNCTION	BIT	MSB							LSB	
		7	6	5	4	3	2 ⁽¹⁾	1 ⁽¹⁾	0 ⁽¹⁾	
Volume	V	0	0	0	0	0	0	0	0	
Output right	OUTR	0	0	0	0	0	0	0	1	
Output left	OUTL	0	0	0	0	0	0	1	0	
No function	–	0	0	0	0	0	0	1	1	
No function	–	0	0	0	0	0	1	0	0	
Bass	BA	0	0	0	0	0	1	0	1	
Treble	TR	0	0	0	0	0	1	1	0	
Switch	S	0	0	0	0	0	1	1	1	

Note

1. Significant subaddress.

Sound control circuit

TEA6324T

Table 2 Definition of third byte after MAD and SAD

FUNCTION	BIT	MSB								LSB	
		7	6	5	4	3	2	1	0		
Volume	V	ZCM ⁽¹⁾	1	V5 ⁽²⁾	V4 ⁽²⁾	V3 ⁽²⁾	V2 ⁽²⁾	V1 ⁽²⁾	V0 ⁽²⁾		
Output right	OUTR	X ⁽³⁾	X ⁽³⁾	OUTR5 ⁽⁴⁾	OUTR4 ⁽⁴⁾	OUTR3 ⁽⁴⁾	OUTR2 ⁽⁴⁾	OUTR1 ⁽⁴⁾	OUTR0 ⁽⁴⁾		
Output left	OUTL	X ⁽³⁾	X ⁽³⁾	OUTL5 ⁽⁵⁾	OUTL4 ⁽⁵⁾	OUTL3 ⁽⁵⁾	OUTL2 ⁽⁵⁾	OUTL1 ⁽⁵⁾	OUTL0 ⁽⁵⁾		
No function	–	X ⁽³⁾	X ⁽³⁾	X ⁽³⁾	X ⁽³⁾	X ⁽³⁾	X ⁽³⁾	X ⁽³⁾	X ⁽³⁾	X ⁽³⁾	X ⁽³⁾
No function	–	X ⁽³⁾	X ⁽³⁾	X ⁽³⁾	X ⁽³⁾	X ⁽³⁾	X ⁽³⁾	X ⁽³⁾	X ⁽³⁾	X ⁽³⁾	X ⁽³⁾
Bass	BA	X ⁽³⁾	X ⁽³⁾	X ⁽³⁾	BA4 ⁽⁶⁾	BA3 ⁽⁶⁾	BA2 ⁽⁶⁾	BA1 ⁽⁶⁾	BA0 ⁽⁶⁾		
Treble	TR	X ⁽³⁾	X ⁽³⁾	X ⁽³⁾	TR4 ⁽⁷⁾	TR3 ⁽⁷⁾	TR2 ⁽⁷⁾	TR1 ⁽⁷⁾	TR0 ⁽⁷⁾		
Switch	S	GMU ⁽⁸⁾	X ⁽³⁾	X ⁽³⁾	X ⁽³⁾	X ⁽³⁾	SC2 ⁽⁹⁾	SC1 ⁽⁹⁾	SC0 ⁽⁹⁾		

Notes

1. Zero crossing mode.
2. Volume control.
3. Don't care bits (logic 1 during testing).
4. Output right.
5. Output left.
6. Bass control.
7. Treble control.
8. Mute control for all outputs (general mute).
9. Source selector control.

Sound control circuit

TEA6324T

Table 3 Volume I setting

G _v (dB)	DATA					
	V5	V4	V3	V2	V1	V0
+20	1	1	1	1	1	1
+19	1	1	1	1	1	0
+18	1	1	1	1	0	1
+17	1	1	1	1	0	0
+16	1	1	1	0	1	1
+15	1	1	1	0	1	0
+14	1	1	1	0	0	1
+13	1	1	1	0	0	0
+12	1	1	0	1	1	1
+11	1	1	0	1	1	0
+10	1	1	0	1	0	1
+9	1	1	0	1	0	0
+8	1	1	0	0	1	1
+7	1	1	0	0	1	0
+6	1	1	0	0	0	1
+5	1	1	0	0	0	0
+4	1	0	1	1	1	1
+3	1	0	1	1	1	0
+2	1	0	1	1	0	1
+1	1	0	1	1	0	0
0	1	0	1	0	1	1
-1	1	0	1	0	1	0
-2	1	0	1	0	0	1
-3	1	0	1	0	0	0
-4	1	0	0	1	1	1
-5	1	0	0	1	1	0
-6	1	0	0	1	0	1
-7	1	0	0	1	0	0
-8	1	0	0	0	1	1
-9	1	0	0	0	1	0
-10	1	0	0	0	0	1
-11	1	0	0	0	0	0
-12	0	1	1	1	1	1
-13	0	1	1	1	1	0
-14	0	1	1	1	0	1
-15	0	1	1	1	0	0
-16	0	1	1	0	1	1
-17	0	1	1	0	1	0

Sound control circuit

TEA6324T

G _v (dB)	DATA					
	V5	V4	V3	V2	V1	V0
-18	0	1	1	0	0	1
-19	0	1	1	0	0	0
-20	0	1	0	1	1	1
-21	0	1	0	1	1	0
-22	0	1	0	1	0	1
-23	0	1	0	1	0	0
-24	0	1	0	0	1	1
-25	0	1	0	0	1	0
-26	0	1	0	0	0	1
-27	0	1	0	0	0	0
-28	0	0	1	1	1	1
-29	0	0	1	1	1	0
-30	0	0	1	1	0	1
-31	0	0	1	1	0	0
Repetition of steps in a range from -28 dB to -31 dB						
-28	0	0	1	0	1	1
-29	0	0	1	0	1	0
-30	0	0	1	0	0	1
-31	0	0	1	0	0	0
-28	0	0	0	1	1	1
-29	0	0	0	1	1	0
-30	0	0	0	1	0	1
-31	0	0	0	1	0	0
-28	0	0	0	0	1	1
-29	0	0	0	0	1	0
-30	0	0	0	0	0	1
-31	0	0	0	0	0	0

Sound control circuit

TEA6324T

Table 4 Volume II setting; note 1

G_V (dB)	DATA					
	OUTL5	OUTL4	OUTL3	OUTL2	OUTL1	OUTL0
	OUTR5	OUTR4	OUTR3	OUTR2	OUTR1	OUTR0
0	1	1	1	1	1	1
-1	1	1	1	1	1	0
-2	1	1	1	1	0	1
-3	1	1	1	1	0	0
-4	1	1	1	0	1	1
-5	1	1	1	0	1	0
-6	1	1	1	0	0	1
-7	1	1	1	0	0	0
-8	1	1	0	1	1	1
-9	1	1	0	1	1	0
-10	1	1	0	1	0	1
-11	1	1	0	1	0	0
-12	1	1	0	0	1	1
-13	1	1	0	0	1	0
-14	1	1	0	0	0	1
-15	1	1	0	0	0	0
-16	1	0	1	1	1	1
-17	1	0	1	1	1	0
-18	1	0	1	1	0	1
-19	1	0	1	1	0	0
-20	1	0	1	0	1	1
-21	1	0	1	0	1	0
-22	1	0	1	0	0	1
-23	1	0	1	0	0	0
-24	1	0	0	1	1	1
-25	1	0	0	1	1	0
-26	1	0	0	1	0	1
-27	1	0	0	1	0	0
-28	1	0	0	0	1	1
-29	1	0	0	0	1	0
-30	1	0	0	0	0	1
-31	1	0	0	0	0	0
-32	0	1	1	1	1	1
-33	0	1	1	1	1	0
-34	0	1	1	1	0	1
-35	0	1	1	1	0	0
-36	0	1	1	0	1	1

Sound control circuit

TEA6324T

G _v (dB)	DATA					
	OUTL5	OUTL4	OUTL3	OUTL2	OUTL1	OUTL0
	OUTR5	OUTR4	OUTR3	OUTR2	OUTR1	OUTR0
-37	0	1	1	0	1	0
-38	0	1	1	0	0	1
-39	0	1	1	0	0	0
-40	0	1	0	1	1	1
-41	0	1	0	1	1	0
-42	0	1	0	1	0	1
-43	0	1	0	1	0	0
-44	0	1	0	0	1	1
-45	0	1	0	0	1	0
-46	0	1	0	0	0	1
-47	0	1	0	0	0	0
-48	0	0	1	1	1	1
-49	0	0	1	1	1	0
-50	0	0	1	1	0	1
-51	0	0	1	1	0	0
-52	0	0	1	0	1	1
-53	0	0	1	0	1	0
-54	0	0	1	0	0	1
-55	0	0	1	0	0	0
Mute	0	0	0	1	1	1
Mute	0	0	0	1	1	0
Mute	0	0	0	1	0	1
Mute	0	0	0	1	0	0
Mute	0	0	0	0	1	1
Mute	0	0	0	0	1	0
Mute	0	0	0	0	0	1
Mute	0	0	0	0	0	0

Note

1. For a particular range the data is always the same, only the subaddress changes.

Sound control circuit

TEA6324T

Table 5 Bass setting

G _{bass} (dB)	DATA				
	BA4	BA3	BA2	BA1	BA0
+18.0	1	1	1	1	1
+16.2	1	1	1	1	0
+18.0	1	1	1	0	1
+16.2	1	1	1	0	0
+18.0	1	1	0	1	1
+16.2	1	1	0	1	0
+14.4	1	1	0	0	1
+12.6	1	1	0	0	0
+10.8	1	0	1	1	1
+9.0	1	0	1	1	0
+7.2	1	0	1	0	1
+5.4	1	0	1	0	0
+3.6	1	0	0	1	1
+1.8	1	0	0	1	0
0 ⁽¹⁾	1	0	0	0	1
0 ⁽²⁾	1	0	0	0	0
-1.8	0	1	1	1	1
-3.6	0	1	1	1	0
-5.4	0	1	1	0	1
-7.2	0	1	1	0	0
-9.0	0	1	0	1	1
-10.8	0	1	0	1	0
-12.6	0	1	0	0	1
-14.4	0	1	0	0	0
-16.2	0	0	1	1	1
-18.0	0	0	1	1	0
-16.2	0	0	1	0	1
-18.0	0	0	1	0	0
Note 3	0	0	0	1	1
Note 3	0	0	0	1	0
Note 3	0	0	0	0	1
Notes 3 and 4	0	0	0	0	0

Notes

1. Recommended data word for step 0 dB.
2. Result of 1.8 dB boost and 1.8 dB attenuation.
3. The last four bass control data words mute the bass response.
4. The last bass control and treble control data words (00000) enable the external equalizer connection.

Sound control circuit

TEA6324T

Table 6 Treble setting

G_{treble} (dB)	DATA				
	TR4	TR3	TR2	TR1	TR0
+12.0	1	1	1	1	1
+10.5	1	1	1	1	0
+12.0	1	1	1	0	1
+10.5	1	1	1	0	0
+12.0	1	1	0	1	1
+10.5	1	1	0	1	0
+12.0	1	1	0	0	1
+10.5	1	1	0	0	0
+9.0	1	0	1	1	1
+7.5	1	0	1	1	0
+6.0	1	0	1	0	1
+4.5	1	0	1	0	0
+3.0	1	0	0	1	1
+1.5	1	0	0	1	0
0 ⁽¹⁾	1	0	0	0	1
0 ⁽²⁾	1	0	0	0	0
-1.5	0	1	1	1	1
-3.0	0	1	1	1	0
-4.5	0	1	1	0	1
-6.0	0	1	1	0	0
-7.5	0	1	0	1	1
-9.0	0	1	0	1	0
-10.5	0	1	0	0	1
-12.0	0	1	0	0	0
Note 3	0	0	1	1	1
Note 3	0	0	1	1	0
Note 3	0	0	1	0	1
Note 3	0	0	1	0	0
Note 3	0	0	0	1	1
Note 3	0	0	0	1	0
Note 3	0	0	0	0	1
Notes 3 and 4	0	0	0	0	0

Notes

1. Recommended data word for step 0 dB.
2. Result of 1.5 dB boost and 1.5 dB attenuation.
3. The last eight treble control data words select treble output.
4. The last treble control and bass control data words (00000) enable the external equalizer connection.

Sound control circuit

TEA6324T

Table 7 Selected input

FUNCTION	DATA		
	SC2	SC1	SC0
Stereo inputs IAL and IAR	1	1	1
Stereo inputs IBL and IBR	1	1	0
No function	1	0	1
No function	1	0	0
Mono input IMO	0	X ⁽¹⁾	X ⁽¹⁾

Note

1. X = don't care bits (logic 1 during testing).

Table 8 Mute mode

FUNCTION	DATA	
	GMU	ZCM
Direct mute off	0	0
Mute off delayed until the next zero crossing	0	1
Direct mute	1	0
Mute delayed until the next zero crossing	1	1

Sound control circuit

TEA6324T

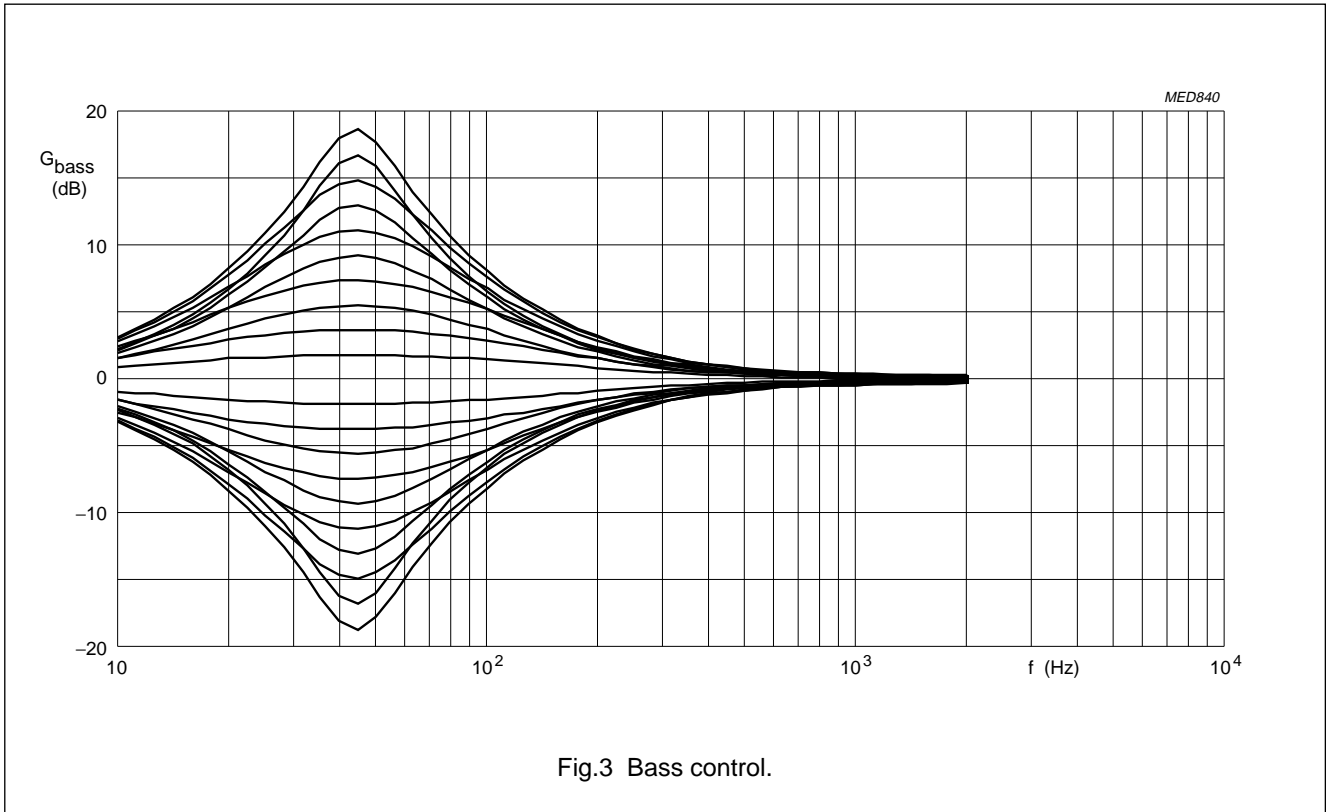

Fig.3 Bass control.

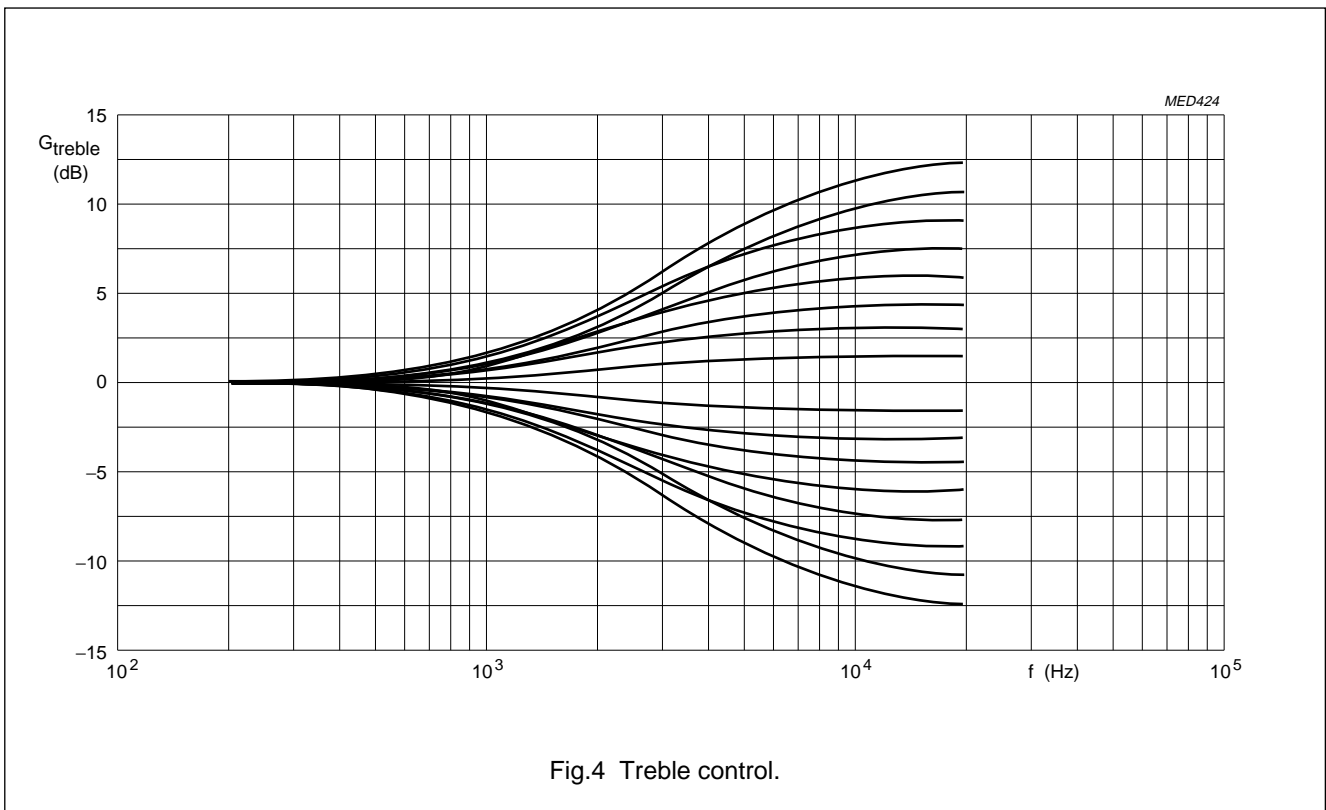
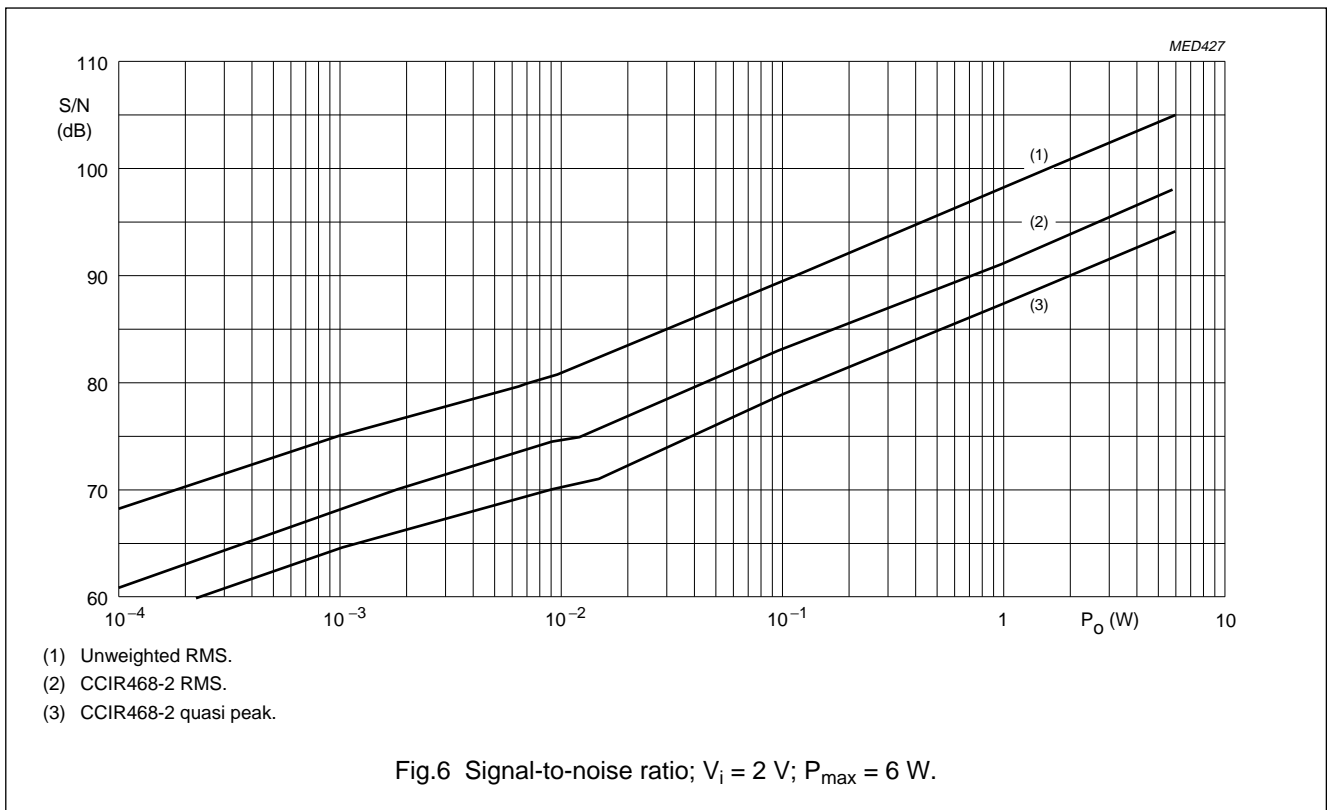
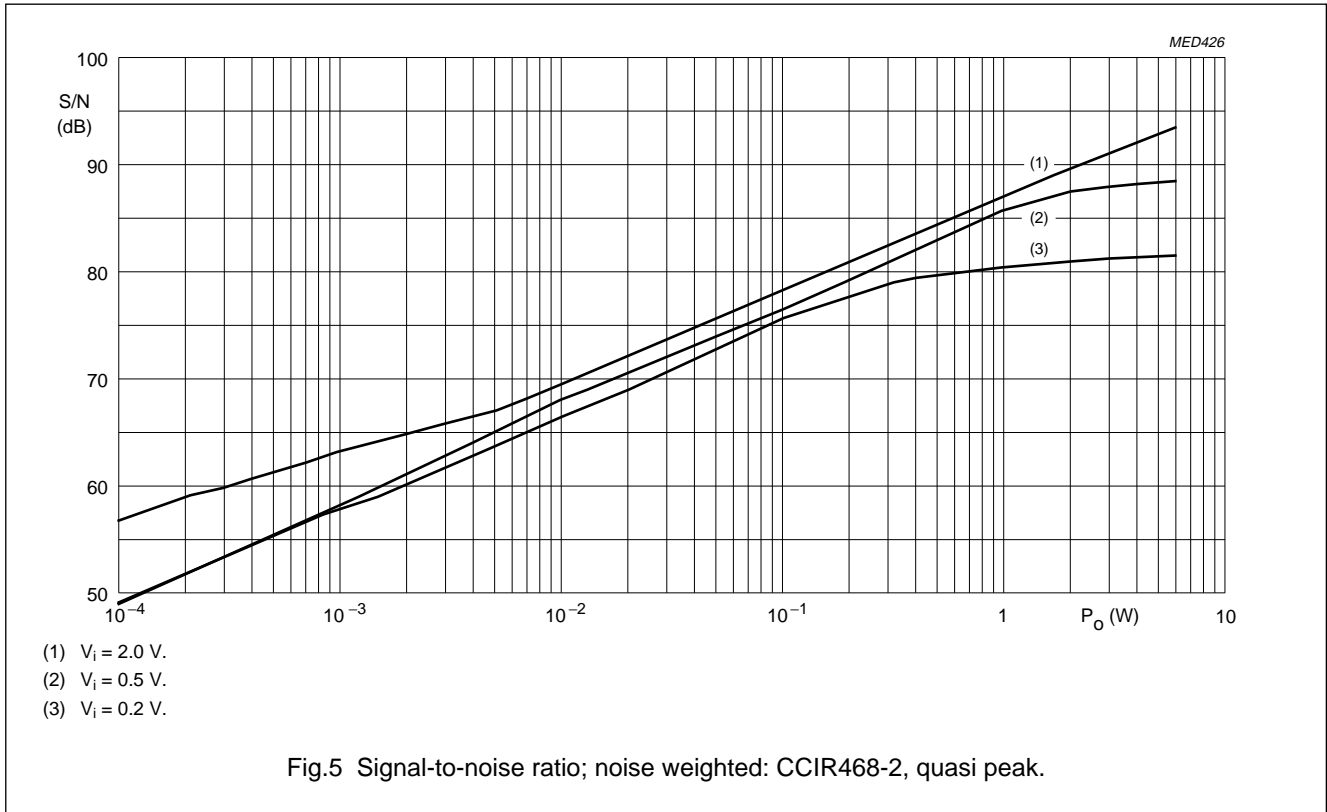

Fig.4 Treble control.

Sound control circuit

TEA6324T



Sound control circuit

TEA6324T

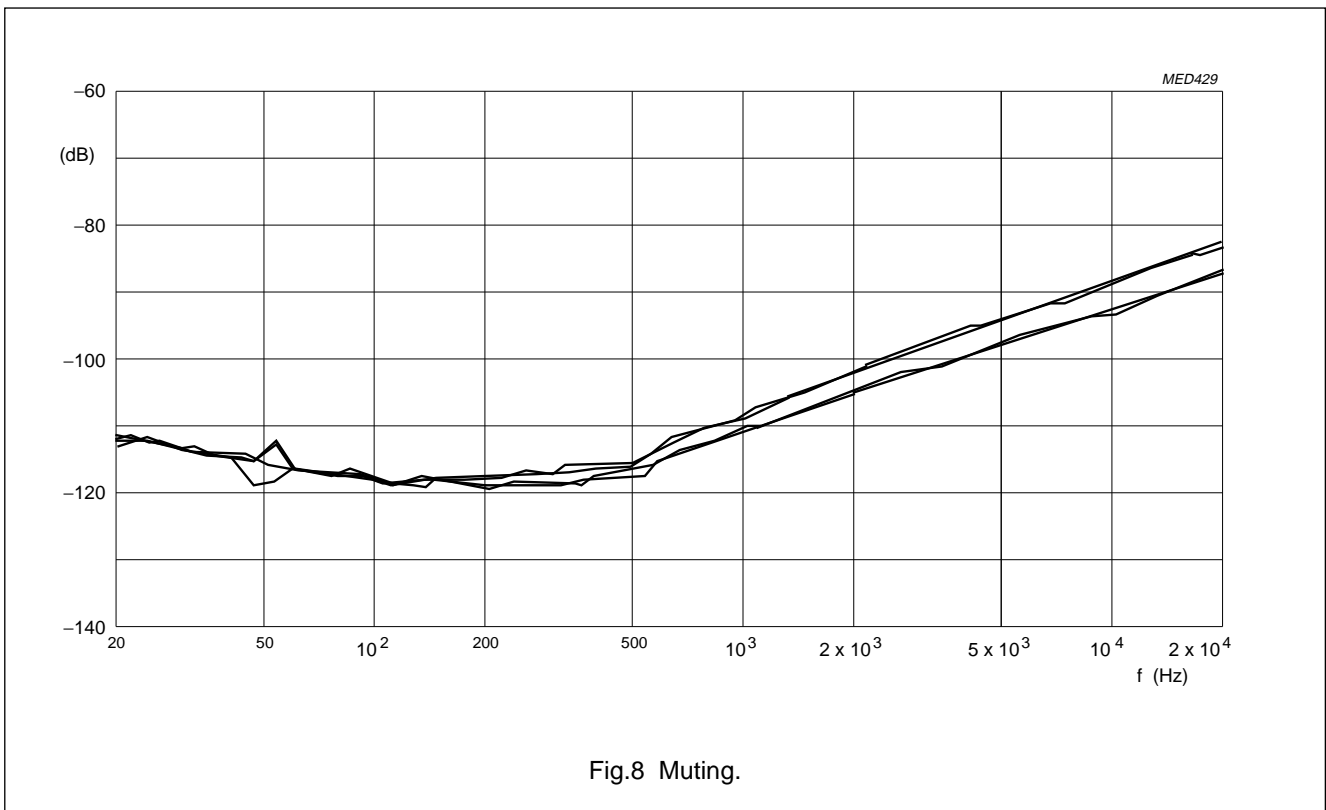
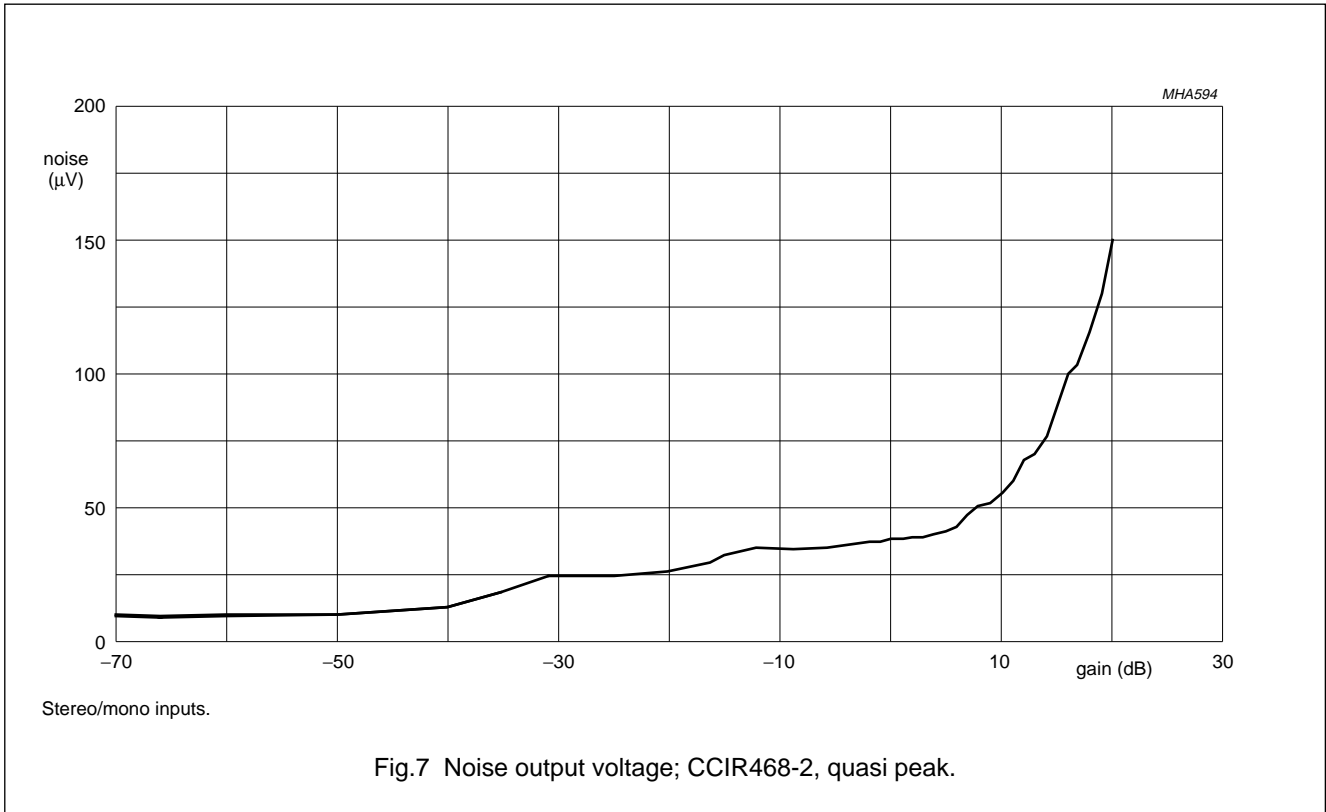

Sound control circuit

TEA6324T

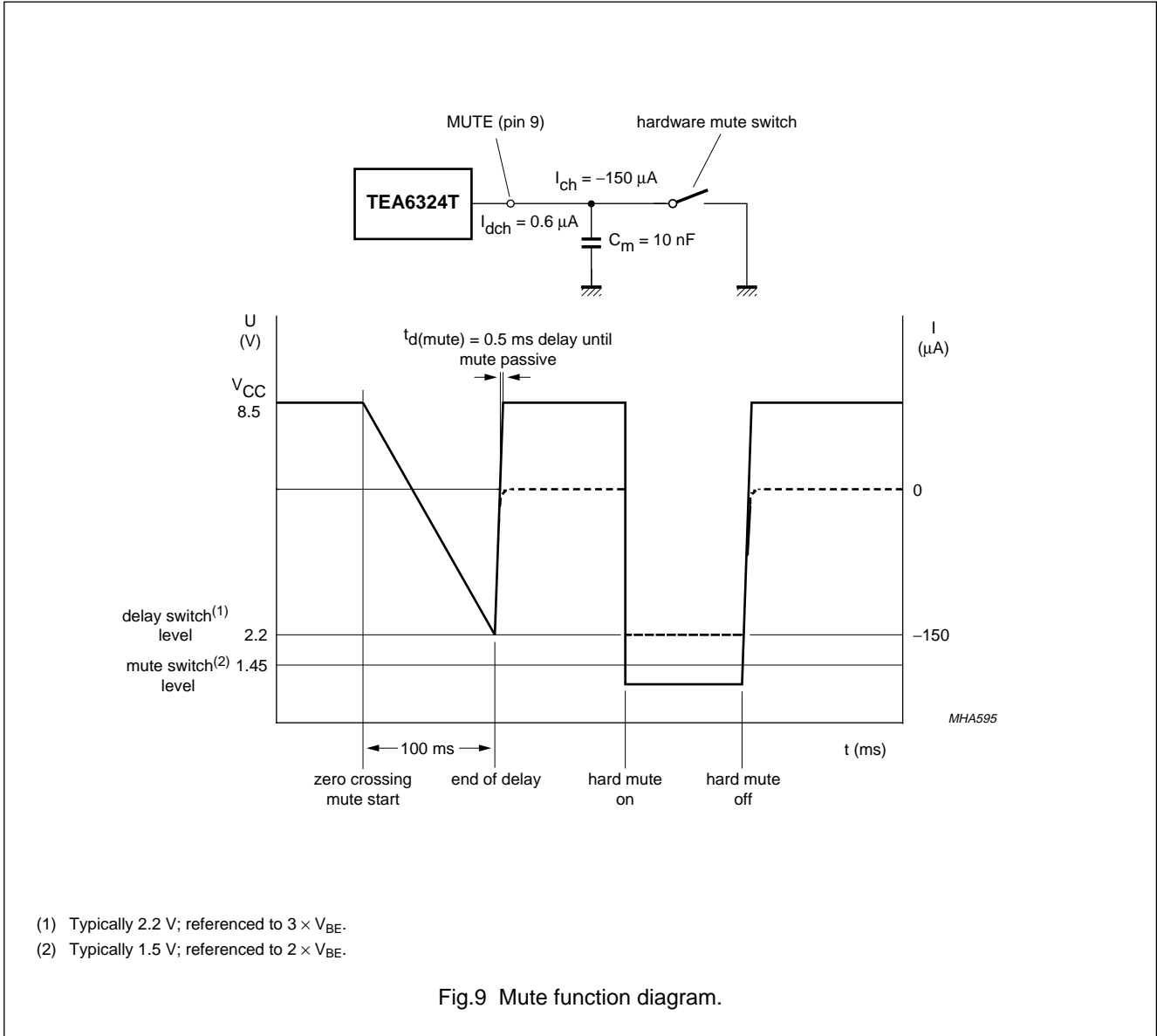

Sound control circuit

TEA6324T

In cases where at the maximum volume position the 20 dB gain is not needed, it is recommended that the maximum boost gain should be used. This coupled with increased attenuation in the last section (volume II), results in a lower noise and offset voltage.

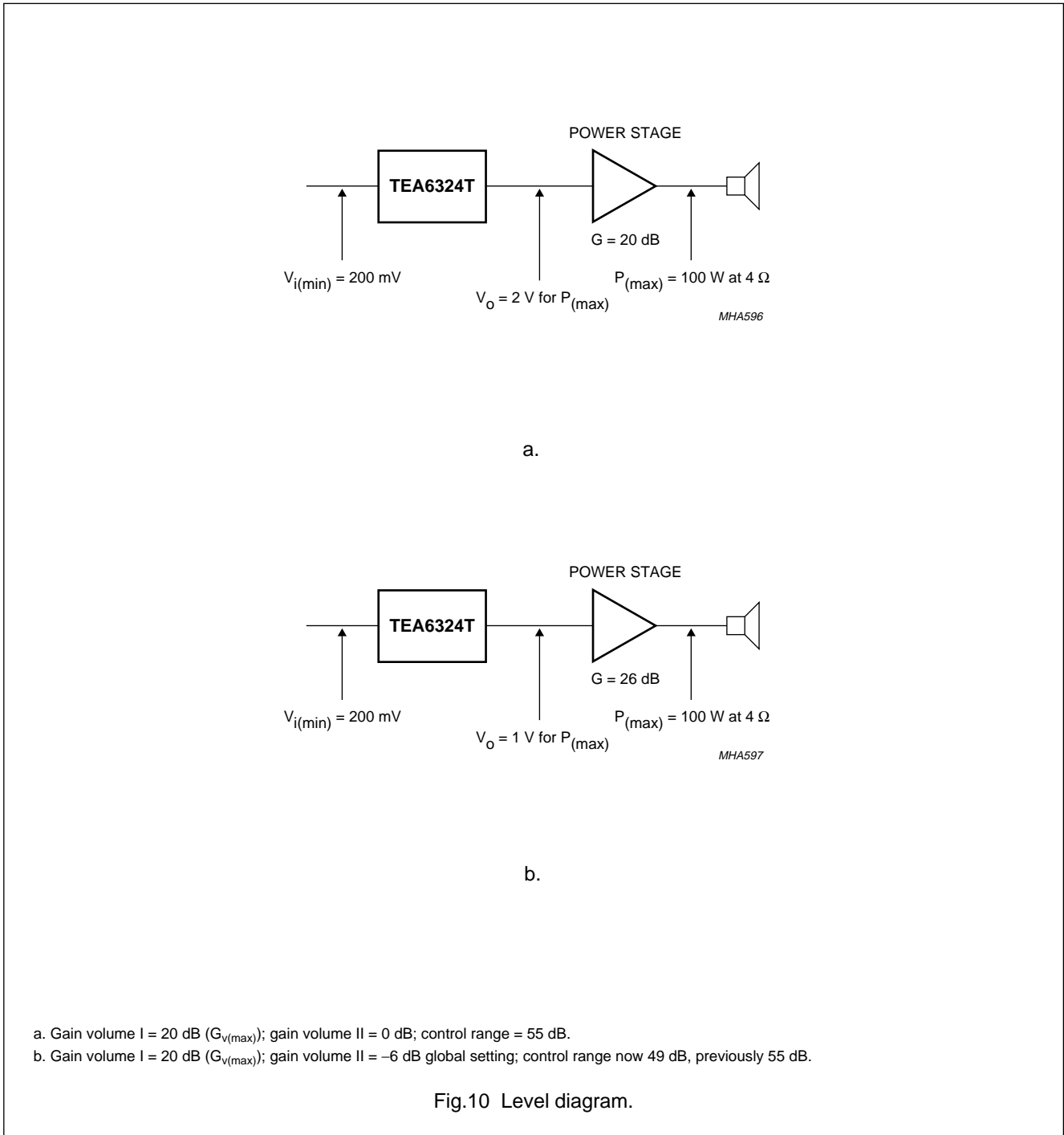

Sound control circuit

TEA6324T

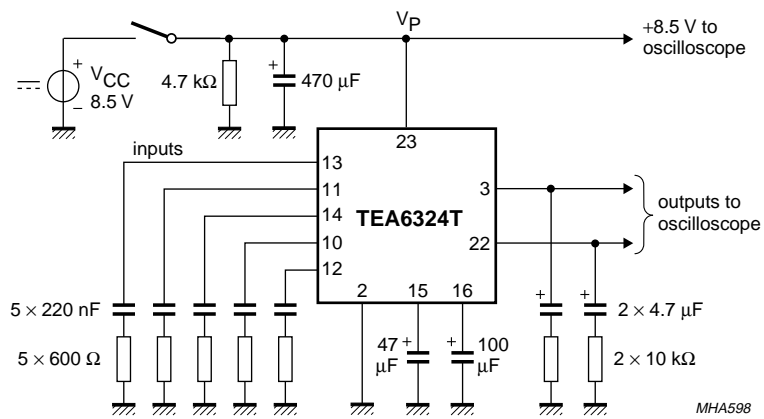
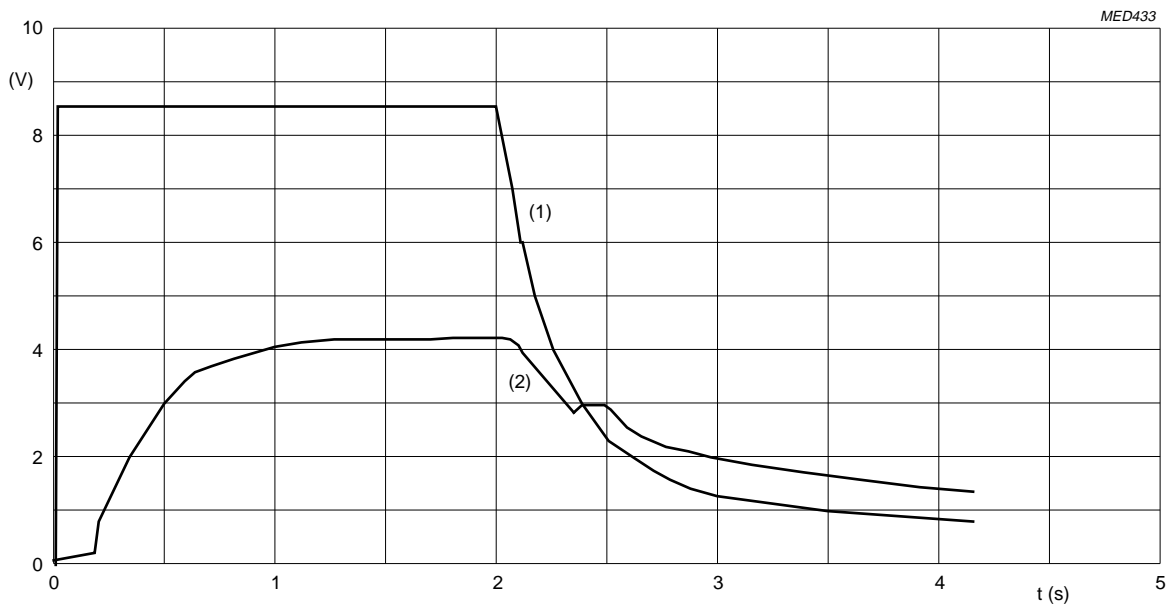

Fig.11 Turn-on/off power supply circuit diagram.



- (1) V_{CC}.
- (2) V_O.

Fig.12 Turn-on/off behaviour.

Sound control circuit

TEA6324T

Selection of input signals by using the zero crossing mute mode

The zero cross mute mode provides for a selection of input sources (A and B) for both left and right channels. The following example (see Fig.15), shows a typical selection for the left input source signals IAL and IBL. The initial selection of these channels produces a modulation click. The click is determined by the difference of the signal values at the time of switching.

At t_1 the maximum possible difference between signals is 7 V (p-p) (see Fig.15) and gives a large click. Using the cross detector no modulation click is audible.

With the selection enabled at t_1 , the microcontroller sets the zero cross bit (ZCM = 1) and then the mute bit (GMU = 1) via the I²C-bus. The output signal follows the input A signal from -4 V, until the next zero crossing occurs and then activates mute.

After a fixed delay time at t_2 , the microcontroller sends the bits for input switching and mute inactive.

The output signal remains muted until the next signal zero crossing of input B (IBL) occurs, and then follows that signal up to 3 V.

With a delay time of 40 ms ($t_2 - t_1$), the external capacitor $C_m = 3.3$ nF. This results with the zero cross function operating at the lowest frequency of 40 Hz determined by the C_m capacitor.

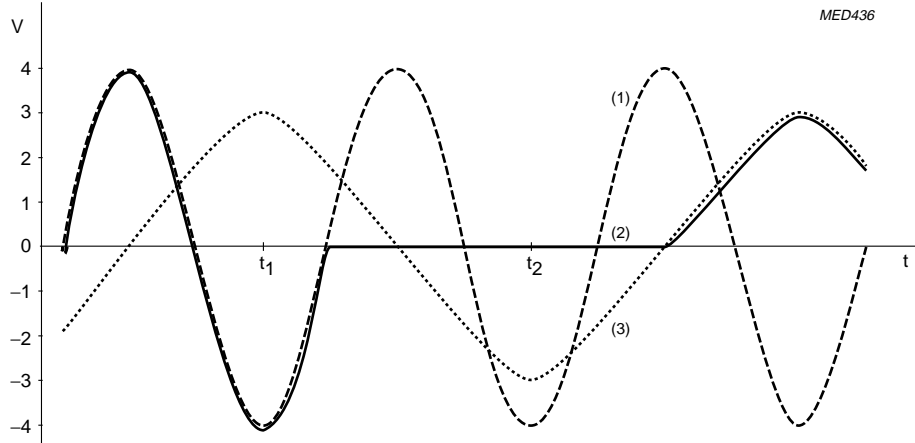

Fig.15 Zero cross function; only one channel shown.

Sound control circuit

TEA6324T

INTERNAL PIN CONFIGURATIONS

Values shown in Figs 16 to 27 are typical DC values; $V_{CC} = 8.5\text{ V}$.

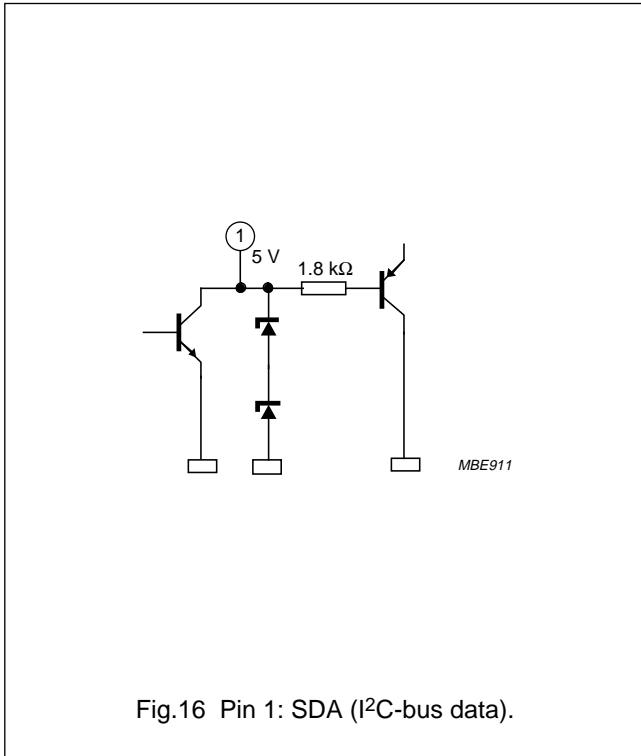

Fig.16 Pin 1: SDA (I²C-bus data).

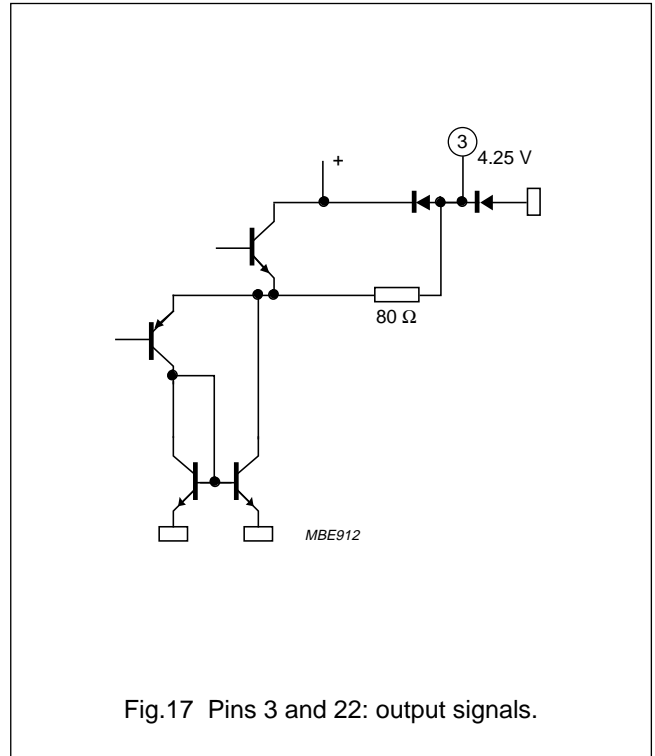

Fig.17 Pins 3 and 22: output signals.

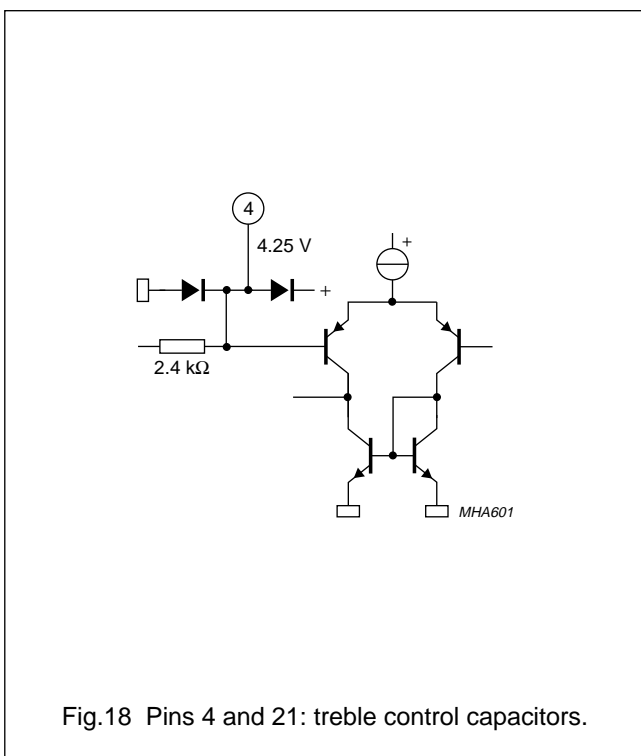

Fig.18 Pins 4 and 21: treble control capacitors.

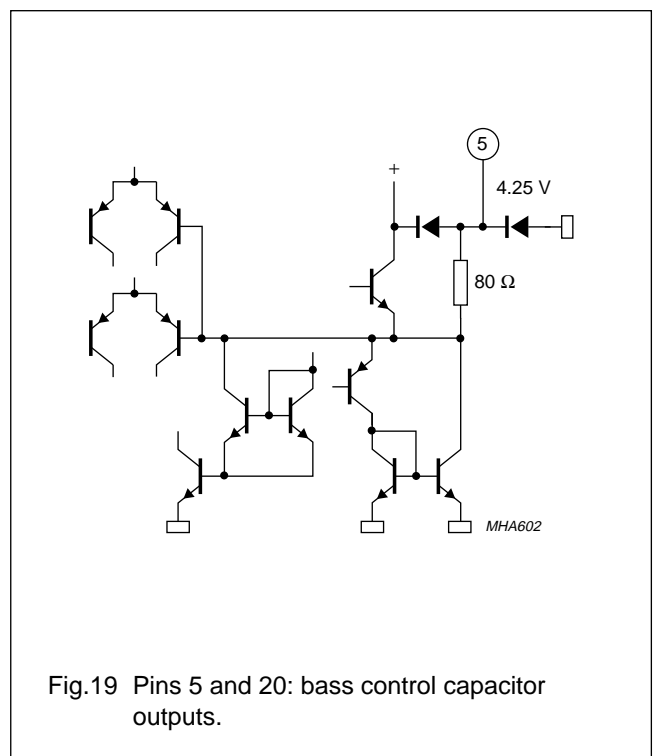
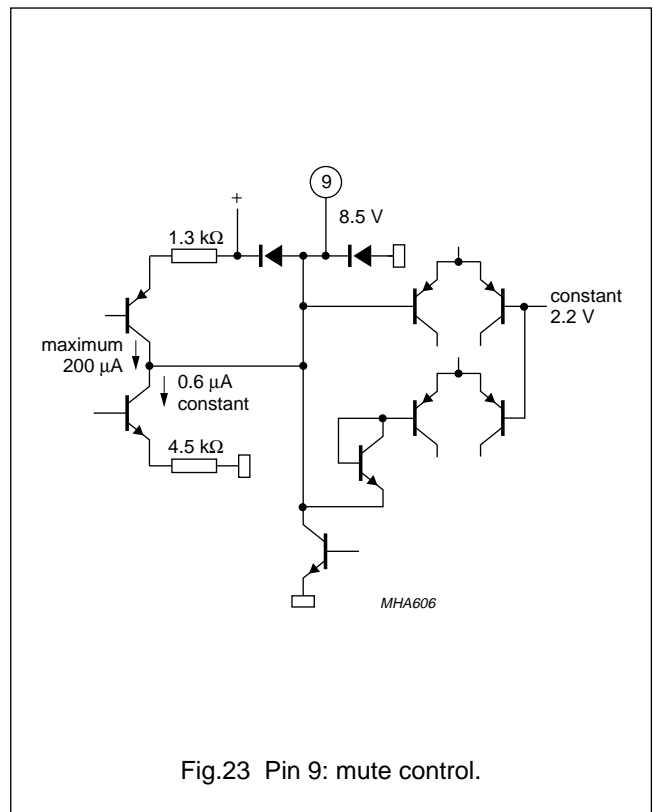
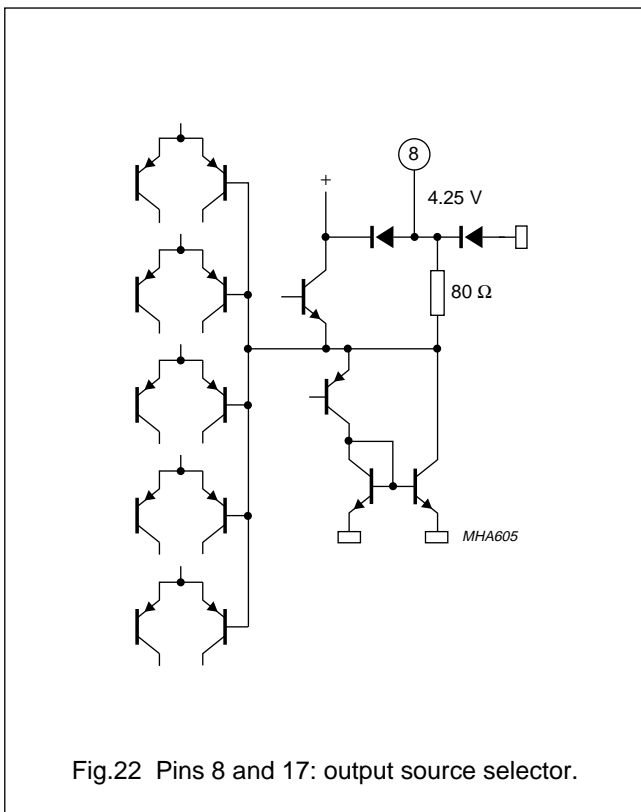
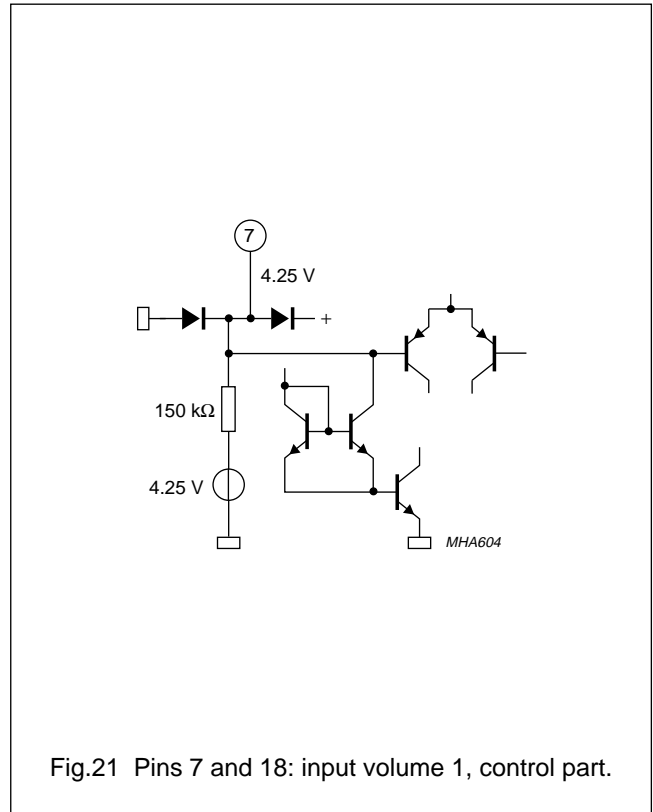
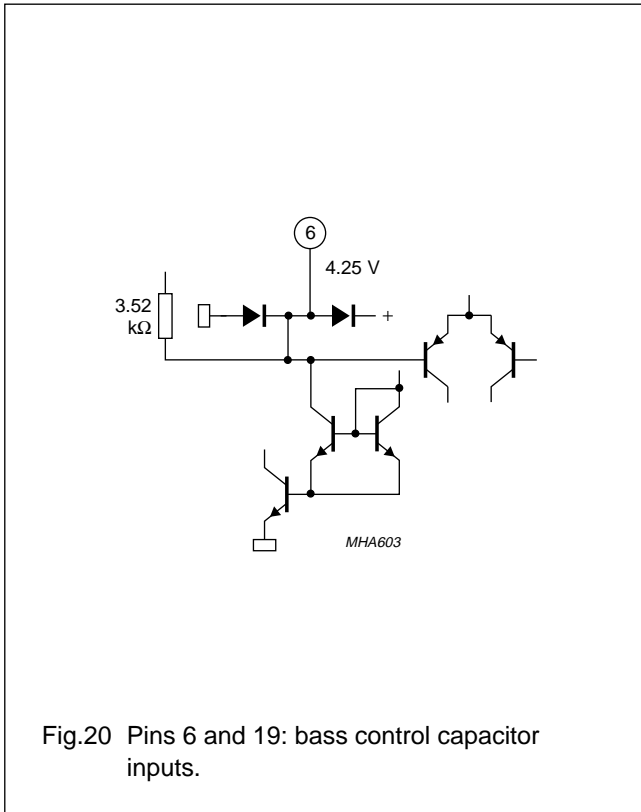

Fig.19 Pins 5 and 20: bass control capacitor outputs.

Sound control circuit

TEA6324T



Sound control circuit

TEA6324T

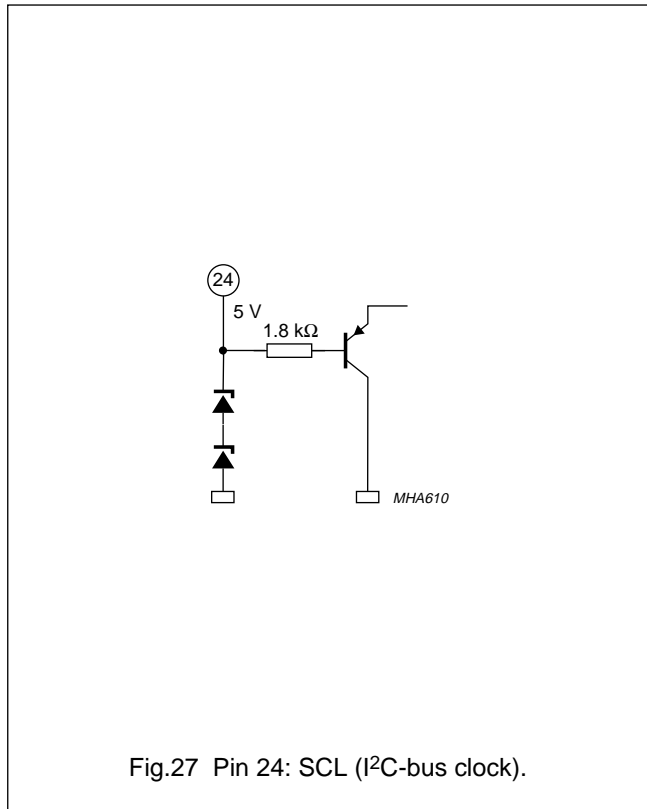
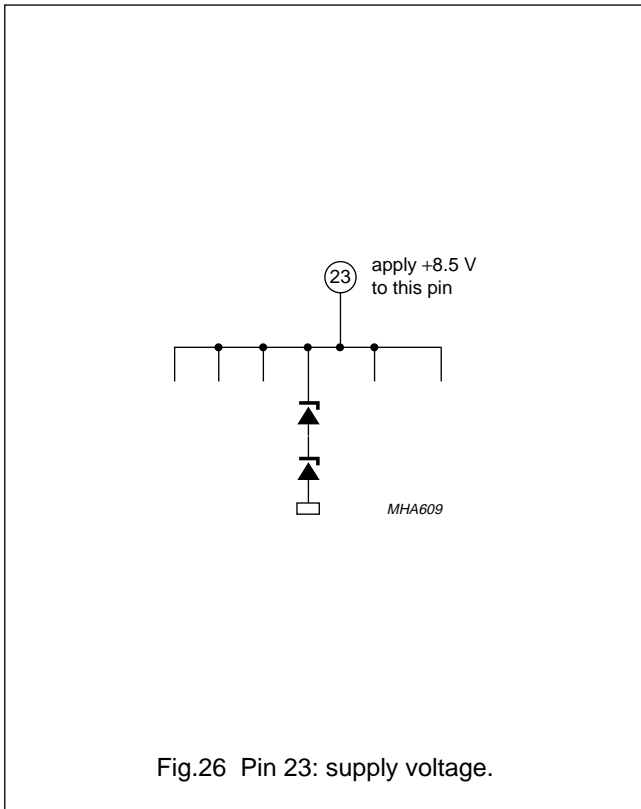
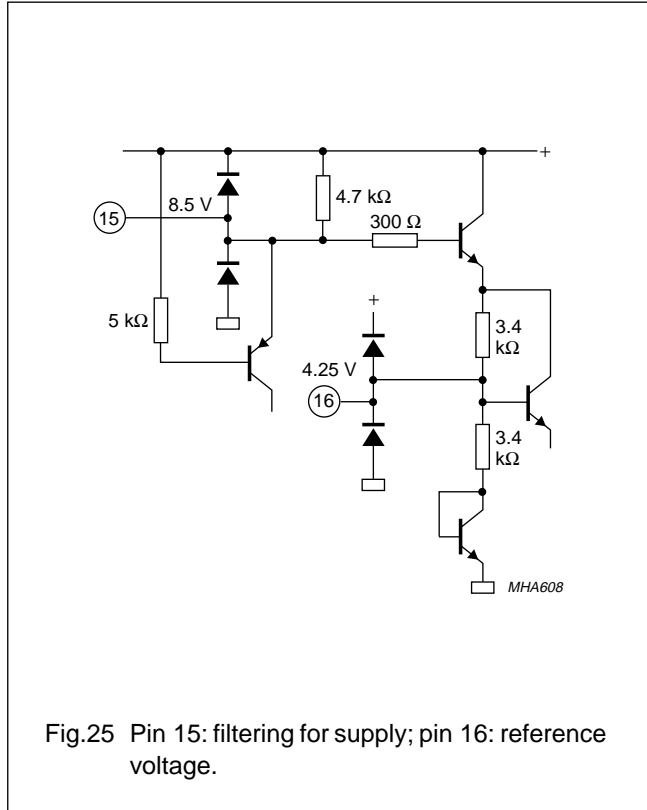
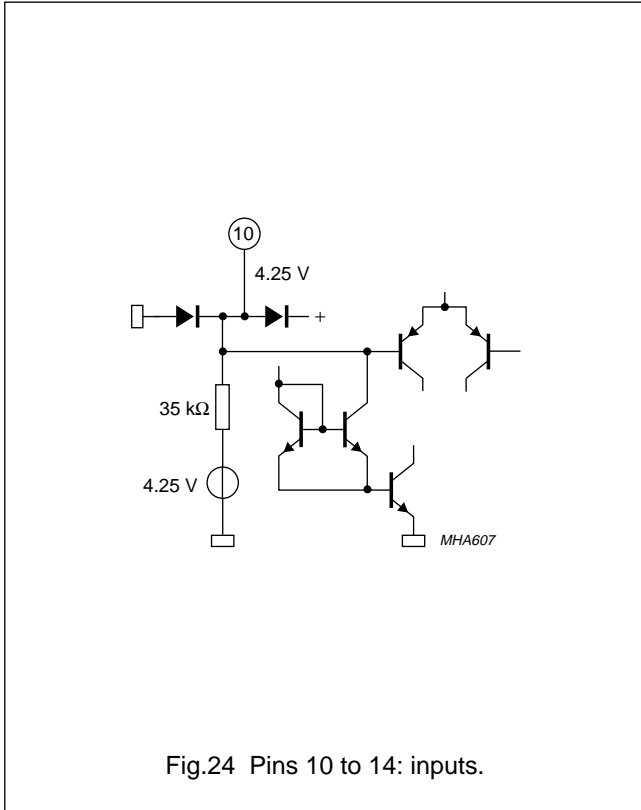

Sound control circuit

TEA6324T

PACKAGE OUTLINE

SO24: plastic small outline package; 24 leads; body width 7.5 mm

SOT137-1

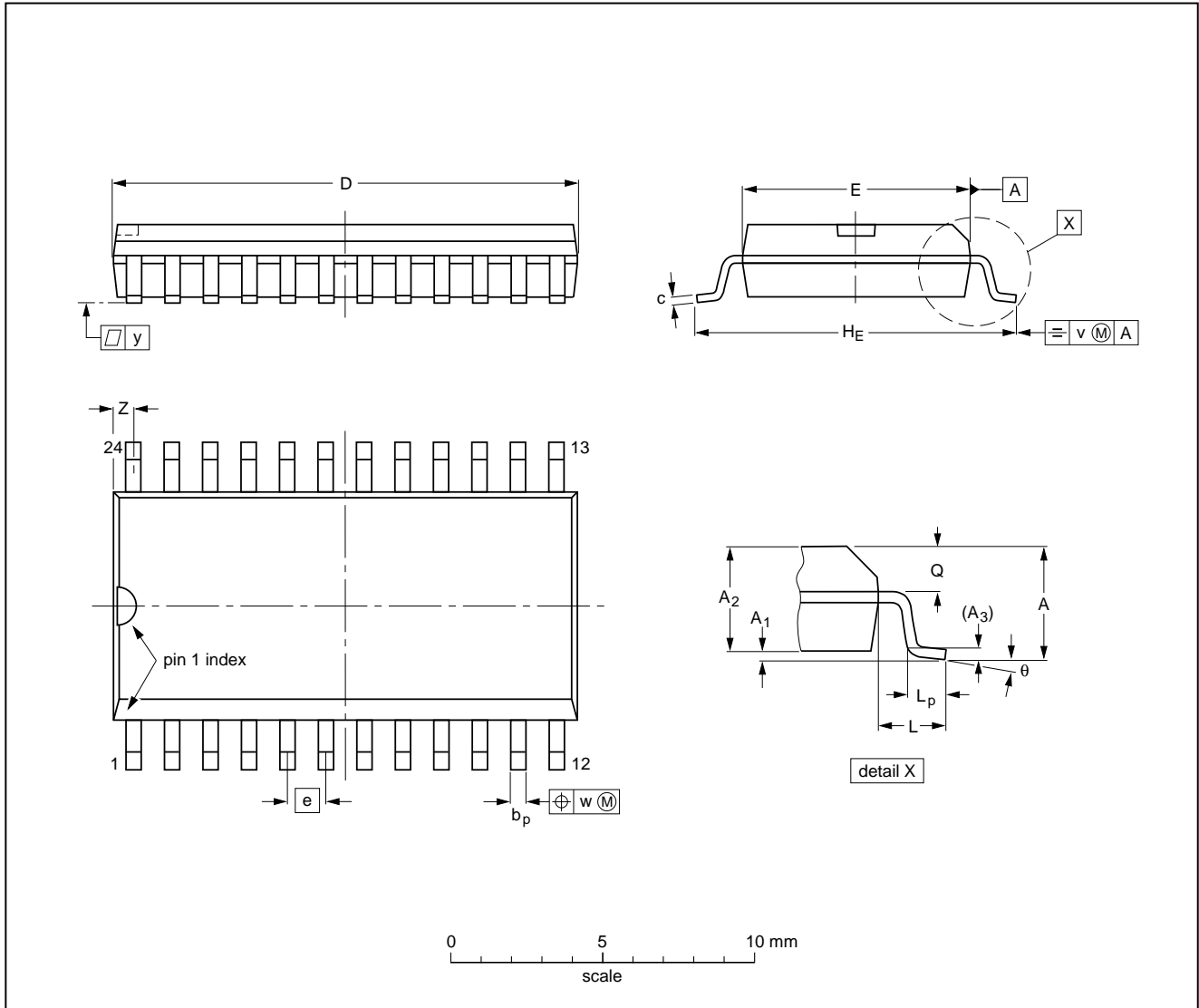

DIMENSIONS (inch dimensions are derived from the original mm dimensions)

UNIT	A max.	A ₁	A ₂	A ₃	b _p	c	D ⁽¹⁾	E ⁽¹⁾	e	H _E	L	L _p	Q	v	w	y	Z ⁽¹⁾	θ
mm	2.65	0.30 0.10	2.45 2.25	0.25	0.49 0.36	0.32 0.23	15.6 15.2	7.6 7.4	1.27	10.65 10.00	1.4	1.1 0.4	1.1 1.0	0.25	0.25	0.1	0.9 0.4	8° 0°
inches	0.10	0.012 0.004	0.096 0.089	0.01	0.019 0.014	0.013 0.009	0.61 0.60	0.30 0.29	0.050	0.42 0.39	0.055	0.043 0.016	0.043 0.039	0.01	0.01	0.004	0.035 0.016	

Note

1. Plastic or metal protrusions of 0.15 mm maximum per side are not included.

OUTLINE VERSION	REFERENCES			EUROPEAN PROJECTION	ISSUE DATE
	IEC	JEDEC	EIAJ		
SOT137-1	075E05	MS-013AD			92-11-17 95-01-24

Sound control circuit

TEA6324T

SOLDERING

Introduction

There is no soldering method that is ideal for all IC packages. Wave soldering is often preferred when through-hole and surface mounted components are mixed on one printed-circuit board. However, wave soldering is not always suitable for surface mounted ICs, or for printed-circuits with high population densities. In these situations reflow soldering is often used.

This text gives a very brief insight to a complex technology. A more in-depth account of soldering ICs can be found in our *"IC Package Databook"* (order code 9398 652 90011).

Reflow soldering

Reflow soldering techniques are suitable for all SO packages.

Reflow soldering requires solder paste (a suspension of fine solder particles, flux and binding agent) to be applied to the printed-circuit board by screen printing, stencilling or pressure-syringe dispensing before package placement.

Several techniques exist for reflowing; for example, thermal conduction by heated belt. Dwell times vary between 50 and 300 seconds depending on heating method. Typical reflow temperatures range from 215 to 250 °C.

Preheating is necessary to dry the paste and evaporate the binding agent. Preheating duration: 45 minutes at 45 °C.

Wave soldering

Wave soldering techniques can be used for all SO packages if the following conditions are observed:

- A double-wave (a turbulent wave with high upward pressure followed by a smooth laminar wave) soldering technique should be used.
- The longitudinal axis of the package footprint must be parallel to the solder flow.
- The package footprint must incorporate solder thieves at the downstream end.

During placement and before soldering, the package must be fixed with a droplet of adhesive. The adhesive can be applied by screen printing, pin transfer or syringe dispensing. The package can be soldered after the adhesive is cured.

Maximum permissible solder temperature is 260 °C, and maximum duration of package immersion in solder is 10 seconds, if cooled to less than 150 °C within 6 seconds. Typical dwell time is 4 seconds at 250 °C.

A mildly-activated flux will eliminate the need for removal of corrosive residues in most applications.

Repairing soldered joints

Fix the component by first soldering two diagonally-opposite end leads. Use only a low voltage soldering iron (less than 24 V) applied to the flat part of the lead. Contact time must be limited to 10 seconds at up to 300 °C. When using a dedicated tool, all other leads can be soldered in one operation within 2 to 5 seconds between 270 and 320 °C.

Sound control circuit

TEA6324T

DEFINITIONS

Data sheet status	
Objective specification	This data sheet contains target or goal specifications for product development.
Preliminary specification	This data sheet contains preliminary data; supplementary data may be published later.
Product specification	This data sheet contains final product specifications.
Limiting values	
Limiting values given are in accordance with the Absolute Maximum Rating System (IEC 134). Stress above one or more of the limiting values may cause permanent damage to the device. These are stress ratings only and operation of the device at these or at any other conditions above those given in the Characteristics sections of the specification is not implied. Exposure to limiting values for extended periods may affect device reliability.	
Application information	
Where application information is given, it is advisory and does not form part of the specification.	

LIFE SUPPORT APPLICATIONS

These products are not designed for use in life support appliances, devices, or systems where malfunction of these products can reasonably be expected to result in personal injury. Philips customers using or selling these products for use in such applications do so at their own risk and agree to fully indemnify Philips for any damages resulting from such improper use or sale.

PURCHASE OF PHILIPS I²C COMPONENTS

Purchase of Philips I²C components conveys a license under the Philips' I²C patent to use the components in the I²C system provided the system conforms to the I²C specification defined by Philips. This specification can be ordered using the code 9398 393 40011.

Sound control circuit

TEA6324T

NOTES

Sound control circuit

TEA6324T

NOTES

Philips Semiconductors – a worldwide company

Argentina: see South America

Australia: 34 Waterloo Road, NORTH RYDE, NSW 2113,
Tel. +61 2 9805 4455, Fax. +61 2 9805 4466

Austria: Computerstr. 6, A-1101 WIEN, P.O. Box 213,
Tel. +43 1 60 101, Fax. +43 1 60 101 1210

Belarus: Hotel Minsk Business Center, Bld. 3, r. 1211, Volodarski Str. 6,
220050 MINSK, Tel. +375 172 200 733, Fax. +375 172 200 773

Belgium: see The Netherlands

Brazil: see South America

Bulgaria: Philips Bulgaria Ltd., Energoproject, 15th floor,
51 James Bourchier Blvd., 1407 SOFIA,
Tel. +359 2 689 211, Fax. +359 2 689 102

Canada: PHILIPS SEMICONDUCTORS/COMPONENTS,
Tel. +1 800 234 7381

China/Hong Kong: 501 Hong Kong Industrial Technology Centre,
72 Tat Chee Avenue, Kowloon Tong, HONG KONG,
Tel. +852 2319 7888, Fax. +852 2319 7700

Colombia: see South America

Czech Republic: see Austria

Denmark: Prags Boulevard 80, PB 1919, DK-2300 COPENHAGEN S,
Tel. +45 32 88 2636, Fax. +45 31 57 1949

Finland: Sinikalliontie 3, FIN-02630 ESPOO,
Tel. +358 9 615800, Fax. +358 9 61580/xxx

France: 4 Rue du Port-aux-Vins, BP317, 92156 SURESNES Cedex,
Tel. +33 1 40 99 6161, Fax. +33 1 40 99 6427

Germany: Hammerbrookstraße 69, D-20097 HAMBURG,
Tel. +49 40 23 53 60, Fax. +49 40 23 536 300

Greece: No. 15, 25th March Street, GR 17778 TAVROS/ATHENS,
Tel. +30 1 4894 339/239, Fax. +30 1 4814 240

Hungary: see Austria

India: Philips INDIA Ltd, Shivsagar Estate, A Block, Dr. Annie Besant Rd.
Worli, MUMBAI 400 018, Tel. +91 22 4938 541, Fax. +91 22 4938 722

Indonesia: see Singapore

Ireland: Newstead, Clonskeagh, DUBLIN 14,
Tel. +353 1 7640 000, Fax. +353 1 7640 200

Israel: RAPAC Electronics, 7 Kehilat Saloniki St, TEL AVIV 61180,
Tel. +972 3 645 0444, Fax. +972 3 649 1007

Italy: PHILIPS SEMICONDUCTORS, Piazza IV Novembre 3,
20124 MILANO, Tel. +39 2 6752 2531, Fax. +39 2 6752 2557

Japan: Philips Bldg 13-37, Kohnan 2-chome, Minato-ku, TOKYO 108,
Tel. +81 3 3740 5130, Fax. +81 3 3740 5077

Korea: Philips House, 260-199 Itaewon-dong, Yongsan-ku, SEOUL,
Tel. +82 2 709 1412, Fax. +82 2 709 1415

Malaysia: No. 76 Jalan Universiti, 46200 PETALING JAYA, SELANGOR,
Tel. +60 3 750 5214, Fax. +60 3 757 4880

Mexico: 5900 Gateway East, Suite 200, EL PASO, TEXAS 79905,
Tel. +9-5 800 234 7381

Middle East: see Italy

Netherlands: Postbus 90050, 5600 PB EINDHOVEN, Bldg. VB,
Tel. +31 40 27 82785, Fax. +31 40 27 88399

New Zealand: 2 Wagener Place, C.P.O. Box 1041, AUCKLAND,
Tel. +64 9 849 4160, Fax. +64 9 849 7811

Norway: Box 1, Manglerud 0612, OSLO,
Tel. +47 22 74 8000, Fax. +47 22 74 8341

Philippines: Philips Semiconductors Philippines Inc.,
106 Valero St. Salcedo Village, P.O. Box 2108 MCC, MAKATI,
Metro MANILA, Tel. +63 2 816 6380, Fax. +63 2 817 3474

Poland: Ul. Lukiska 10, PL 04-123 WARSZAWA,
Tel. +48 22 612 2831, Fax. +48 22 612 2327

Portugal: see Spain

Romania: see Italy

Russia: Philips Russia, Ul. Usatcheva 35A, 119048 MOSCOW,
Tel. +7 095 755 6918, Fax. +7 095 755 6919

Singapore: Lorong 1, Toa Payoh, SINGAPORE 1231,
Tel. +65 350 2538, Fax. +65 251 6500

Slovakia: see Austria

Slovenia: see Italy

South Africa: S.A. PHILIPS Pty Ltd., 195-215 Main Road Martindale,
2092 JOHANNESBURG, P.O. Box 7430 Johannesburg 2000,
Tel. +27 11 470 5911, Fax. +27 11 470 5494

South America: Rua do Rocio 220, 5th floor, Suite 51,
04552-903 São Paulo, SÃO PAULO - SP, Brazil,
Tel. +55 11 821 2333, Fax. +55 11 829 1849

Spain: Balmes 22, 08007 BARCELONA,
Tel. +34 3 301 6312, Fax. +34 3 301 4107

Sweden: Kottbygatan 7, Akalla, S-16485 STOCKHOLM,
Tel. +46 8 632 2000, Fax. +46 8 632 2745

Switzerland: Allmendstrasse 140, CH-8027 ZÜRICH,
Tel. +41 1 488 2686, Fax. +41 1 481 7730

Taiwan: Philips Semiconductors, 6F, No. 96, Chien Kuo N. Rd., Sec. 1,
TAIPEI, Taiwan Tel. +886 2 2134 2870, Fax. +886 2 2134 2874

Thailand: PHILIPS ELECTRONICS (THAILAND) Ltd.,
209/2 Sanpavuth-Bangna Road Prakanong, BANGKOK 10260,
Tel. +66 2 745 4090, Fax. +66 2 398 0793

Turkey: Talatpasa Cad. No. 5, 80640 GÜLTEPE/ISTANBUL,
Tel. +90 212 279 2770, Fax. +90 212 282 6707

Ukraine: PHILIPS UKRAINE, 4 Patrice Lumumba str., Building B, Floor 7,
252042 KIEV, Tel. +380 44 264 2776, Fax. +380 44 268 0461

United Kingdom: Philips Semiconductors Ltd., 276 Bath Road, Hayes,
MIDDLESEX UB3 5BX, Tel. +44 181 730 5000, Fax. +44 181 754 8421

United States: 811 East Arques Avenue, SUNNYVALE, CA 94088-3409,
Tel. +1 800 234 7381

Uruguay: see South America

Vietnam: see Singapore

Yugoslavia: PHILIPS, Trg N. Pasica 5/v, 11000 BEOGRAD,
Tel. +381 11 625 344, Fax. +381 11 635 777

For all other countries apply to: Philips Semiconductors, Marketing & Sales Communications,
Building BE-p, P.O. Box 218, 5600 MD EINDHOVEN, The Netherlands, Fax. +31 40 27 24825

Internet: <http://www.semiconductors.philips.com>

© Philips Electronics N.V. 1997

SCA53

All rights are reserved. Reproduction in whole or in part is prohibited without the prior written consent of the copyright owner.

The information presented in this document does not form part of any quotation or contract, is believed to be accurate and reliable and may be changed without notice. No liability will be accepted by the publisher for any consequence of its use. Publication thereof does not convey nor imply any license under patent- or other industrial or intellectual property rights.

Printed in The Netherlands

547027/1200/01/pp36

Date of release: 1997 Mar 13

Document order number: 9397 750 01599

Let's make things better.