

19-2494; Rev 2; 8/03

EVALUATION KIT
AVAILABLE

MAXIM

5GHz Linear Power Amplifiers

General Description

The MAX2840/MAX2841 low-cost linear power amplifiers (PAs) operate in the 5GHz to 6GHz band. The PAs are designed for high gain and high linearity, which makes them ideal for use in IEEE 802.11a OFDM systems. The MAX2840 delivers +15dBm output power, and the MAX2841 delivers +18dBm output power.

The devices integrate a power detector that provides over 15dB dynamic range and ± 1.0 dB accuracy. With the detector circuit built in, an automatic level control (ALC) function can be easily implemented.

The PAs also feature an external bias control function. The idle current can be adjusted through an external DAC to improve efficiency at reduced output powers while maintaining sufficient ACPR and EVM performance. As a result, the highest possible efficiency is maintained at all power levels. The MAX2840/MAX2841 operate over a single +2.7V to +3.6V power-supply range. An on-chip shutdown feature reduces operating current to less than 10 μ A, eliminating the need for an external supply switch.

The MAX2840/MAX2841 are packaged in a 2mm \times 1.5mm chip-scale package (UCSP™), which significantly minimizes parasitic effects and reduces the required board area.

Applications

IEEE 802.11a OFDM WLAN
HiperLAN2 WLAN
5GHz Cordless Phones

Functional Diagram

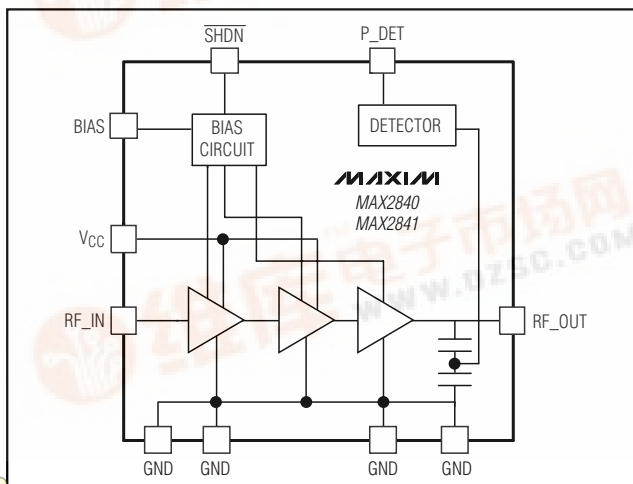

Features

- ◆ 5GHz to 6GHz Operating Frequency Range
- ◆ High Linear Output Power
 - +15dBm at 5.25GHz (MAX2840)
 - +18dBm at 5.25GHz (MAX2841)
- ◆ 22dB Power Gain
- ◆ On-Chip Detector With 15dB Dynamic Range and ± 1.0 dB Detector Accuracy
- ◆ Simple Input and Output Matching
- ◆ +2.7V to +3.6V Single Supply
- ◆ Shutdown Mode With Less than 10 μ A Current
- ◆ 2mm \times 1.5mm Chip-Scale Package

Ordering Information

PART	TEMP RANGE	PIN-PACKAGE	TOP MARK
MAX2840EBC-T	-40°C to +85°C	3 \times 4 UCSP	AAT
MAX2841EBC-T	-40°C to +85°C	3 \times 4 UCSP	AAU

Typical Operating Circuit appears at end of data sheet.

Pin Configuration

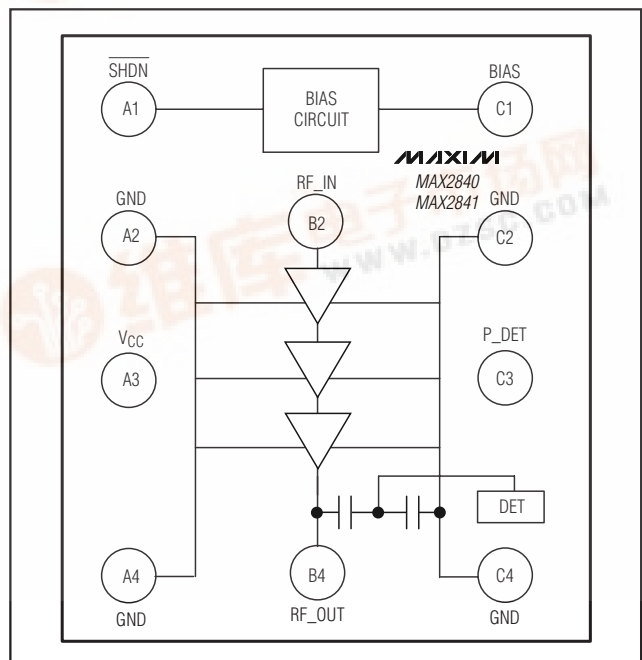

MAX2840/MAX2841

5GHz Linear Power Amplifiers

ABSOLUTE MAXIMUM RATINGS

V_{CC} to GND	-0.3V to +4.2V	Continuous Power Dissipation ($T_A = +85^\circ\text{C}$)	
$\overline{\text{SHDN}}$, BIAS, P_DET, RF_OUT to GND	-0.3V to ($V_{CC} + 0.3\text{V}$)	3 × 4 UCSP (derate 80mW/°C above +85°C)	1.6W
RF_IN to GND	-0.3V to +0.9V	Operating Temperature Range	-40°C to +85°C
Input Power	+10dBm	Thermal Resistance	25°C/W
Max VSWR Without Damage	10:1	Junction Temperature	+150°C
Max VSWR for Stable Operation	5:1	Storage Temperature Range	-65°C to +125°C
Continuous Operating Lifetime	10yrs × 0.93 ^($T_A - 60^\circ\text{C}$)	Soldering Temperature (10s)	+260°C
(for operating temperature 60°C < T_A < 85°C)			

Stresses beyond those listed under "Absolute Maximum Ratings" may cause permanent damage to the device. These are stress ratings only, and functional operation of the device at these or any other conditions beyond those indicated in the operational sections of the specifications is not implied. Exposure to absolute maximum rating conditions for extended periods may affect device reliability.



CAUTION! ESD SENSITIVE DEVICE

DC ELECTRICAL CHARACTERISTICS

($V_{CC} = +2.7\text{V}$ to +3.6V, GND = 0V, $\overline{\text{SHDN}} = V_{CC}$, $V_{DAC} = 1.6\text{V}$ (MAX2840), $V_{DAC} = 1.9\text{V}$ (MAX2841), $T_A = -40^\circ\text{C}$ to +85°C. Typical values are measured at $V_{CC} = +3.3\text{V}$, $f_{RF} = 5.25\text{GHz}$, $T_A = +25^\circ\text{C}$, unless otherwise noted.) (Note 1)

PARAMETER	CONDITIONS	MIN	TYP	MAX	UNITS
Supply Voltage		2.7		3.6	V
Supply Current	$P_{OUT} = 15\text{dBm}$, $V_{CC} = 3.3\text{V}$, MAX2840 (Notes 2, 3)		155	190	mA
	$P_{OUT} = 18\text{dBm}$, $V_{CC} = 3.3\text{V}$, MAX2841 (Notes 2, 3)		260	310	
	No RF signal, RF input and output terminated with 50Ω	MAX2840	120		
		MAX2841	165		
	$\overline{\text{SHDN}} = 0\text{V}$, no RF signal		0.5	10	μA
Digital Input Voltage High		2			V
Digital Input Voltage Low				0.8	V
Digital Input Current High				5	μA
Digital Input Current Low		-1			μA

AC ELECTRICAL CHARACTERISTICS

(MAX2840/MAX2841 EV kits, $V_{CC} = +2.7\text{V}$ to +3.6V, GND = 0V, $\overline{\text{SHDN}} = V_{CC}$, $V_{DAC} = 1.6\text{V}$ (MAX2840), $V_{DAC} = 1.9\text{V}$ (MAX2841), $T_A = +25^\circ\text{C}$. Typical values are measured at $V_{CC} = +3.3\text{V}$, $f_{RF} = 5.25\text{GHz}$, unless otherwise noted.) (Note 3)

PARAMETER	CONDITIONS	MIN	TYP	MAX	UNITS
RF Frequency Range	(Note 4)	5.15		5.35	GHz
Power Gain (Note 5)	$P_{OUT} = 15\text{dBm}$ (MAX2840)		22.8		dB
	$P_{OUT} = 18\text{dBm}$ (MAX2841)		22.5		
Power Gain	$T_A = +85^\circ\text{C}$, $V_{CC} = 3.3\text{V}$ (Note 5)	19.5			dB
Output Power	ACPR: -23dBc at 11MHz offset, -31dBc at 20MHz offset, -43dBc at 30MHz offset over 100kHz BW; OFDM, 64-QAM signal (Notes 6, 7)	MAX2840	15		dBm
		MAX2841	18		
Error Vector Magnitude (Note 7)	$P_{OUT} = 15\text{dBm}$ (MAX2840)		3.9		%RMS
	$P_{OUT} = 18\text{dBm}$ (MAX2841)		3.5		
Harmonic Output (2f, 3f)	$P_{OUT} = 15\text{dBm}$ (MAX2840) $P_{OUT} = 18\text{dBm}$ (MAX2841)		-45		dBc

5GHz Linear Power Amplifiers

AC ELECTRICAL CHARACTERISTICS (continued)

(MAX2840/MAX2841 EV kits, $V_{CC} = +2.7V$ to $+3.6V$, $GND = 0V$, $\overline{SHDN} = V_{CC}$, $V_{DAC} = 1.6V$ (MAX2840), $V_{DAC} = 1.9V$ (MAX2841), $T_A = +25^\circ C$. Typical values are measured at $V_{CC} = +3.3V$, $f_{RF} = 5.25GHz$, unless otherwise noted.) (Note 3)

PARAMETER	CONDITIONS	MIN	TYP	MAX	UNITS
Input VSWR			1.8:1		
Output VSWR			1.9:1		
Nonharmonic Spurious Output				-60	dBc
Power Ramp Turn-On Time	\overline{SHDN} from low to high (Note 8)		1	1.5	μs
Power Ramp Turn-Off Time	\overline{SHDN} from high to low (Note 8)		1	1.5	μs
RF Output Detector Response Time	External capacitor, $C = 10pF$		0.5	1.5	μs
RF Output Detector Voltage Range	Load $> 100k\Omega$ (Note 7)	$P_{OUT} = 15dBm$ (MAX2840)	1.1		V
		$P_{OUT} = 18dBm$ (MAX2841)	1.2		
		$P_{OUT} = 12dBm$ (MAX2840)	1		
		$P_{OUT} = 15dBm$ (MAX2841)	1		
		$P_{OUT} = 5dBm$ (MAX2840)	0.7		
		$P_{OUT} = 5dBm$ (MAX2841)	0.7		
RF Output Detector Accuracy	When output detector voltage = 1.2V		± 1		dB
RF Output Detector Slope	At maximum output power		6		dB/V

Note 1: Specifications over temperature range are guaranteed by design. Production tests are performed at $T_A = +85^\circ C$.

Note 2: 5.25GHz 64-QAM modulated OFDM signal is applied at RF input port.

Note 3: Min and max values are guaranteed by design and characterization.

Note 4: Operation outside of this frequency range is possible but not guaranteed.

Note 5: Specifications are corrected for board losses on the EV kits (0.3dB at the input, 0.3dB at the output).

Note 6: RF input signal is following IEEE 802.11a standards.

Note 7: Specifications are corrected for board losses on the EV kits (0.3dB at the output).

Note 8: The total turn-on/settling time required for PA output power is within 0.5dB range of the final value.

Typical Operating Characteristics

(MAX2840/MAX2841 EV kits, $V_{CC} = +2.7V$ to $+3.6V$, $GND = 0V$, $\overline{SHDN} = V_{CC}$, $V_{DAC} = 1.6V$ (MAX2840), $V_{DAC} = 1.9V$ (MAX2841), $T_A = +25^\circ C$. Typical values are measured at $V_{CC} = +3.3V$, $f_{RF} = 5.25GHz$, unless otherwise noted.) (Note 2)

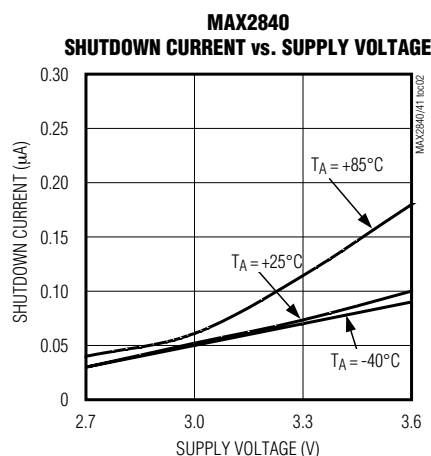
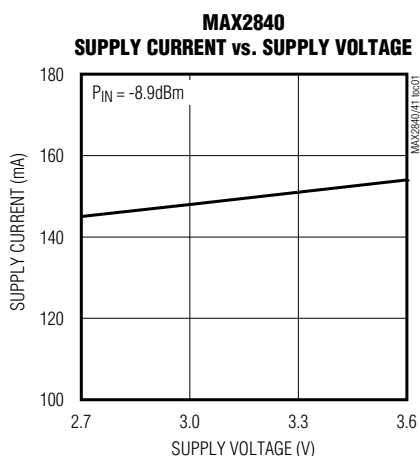

5GHz Linear Power Amplifiers

Typical Operating Characteristics (continued)

(MAX2840/MAX2841 EV kits, $V_{CC} = +2.7V$ to $+3.6V$, $GND = 0V$, $\overline{SHDN} = V_{CC}$, $V_{DAC} = 1.6V$ (MAX2840), $V_{DAC} = 1.9V$ (MAX2841), $T_A = +25^\circ C$. Typical values are measured at $V_{CC} = +3.3V$, $f_{RF} = 5.25GHz$, unless otherwise noted.) (Note 2)

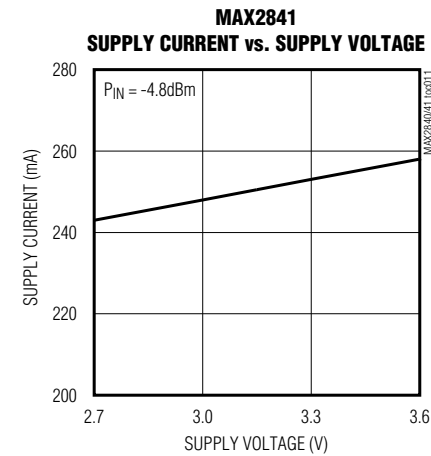
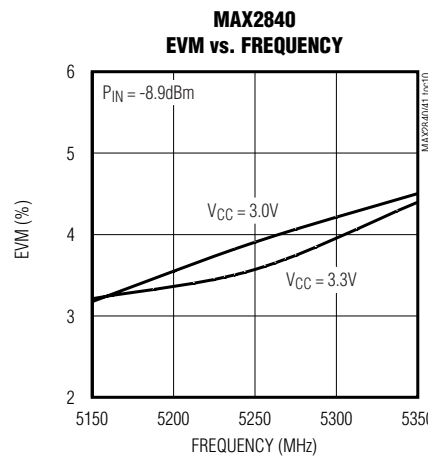
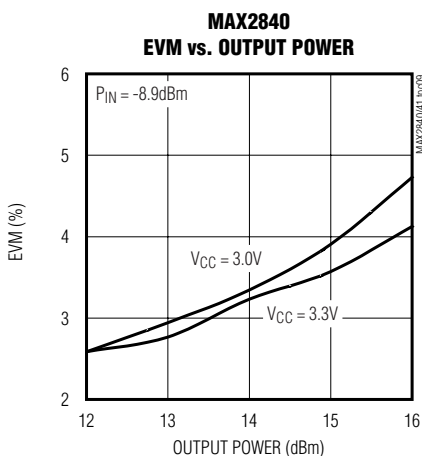
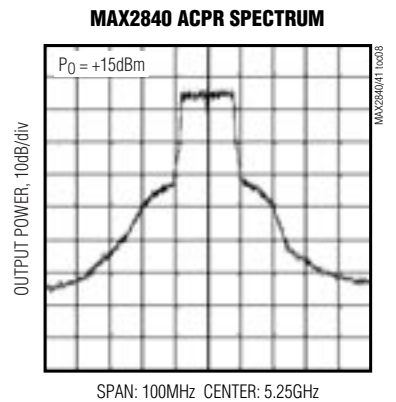
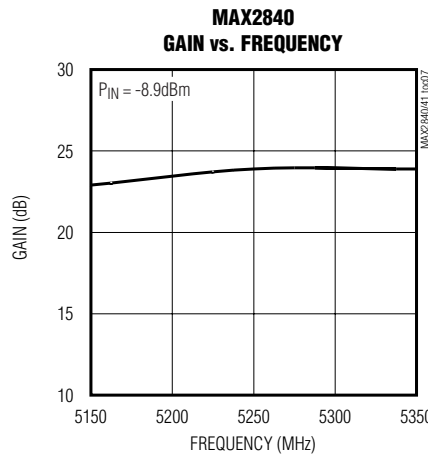
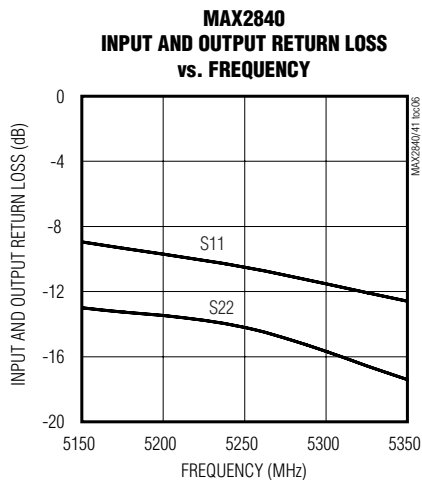
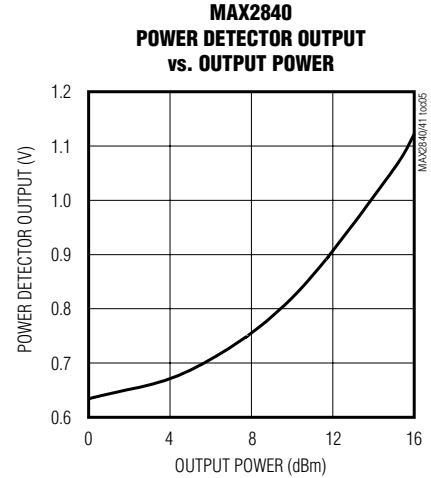
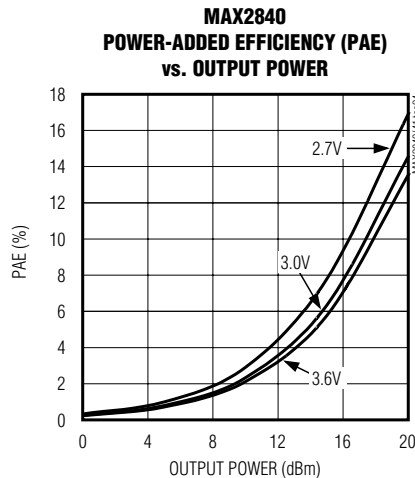
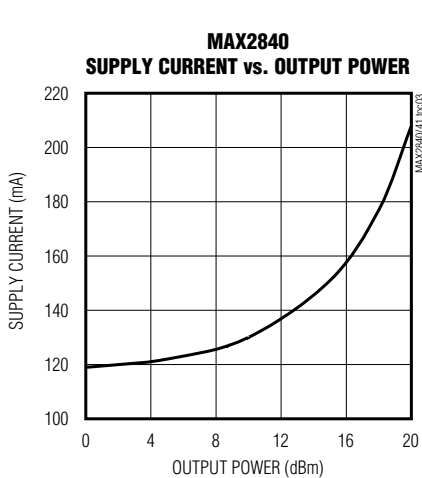

5GHz Linear Power Amplifiers

Typical Operating Characteristics (continued)

(MAX2840/MAX2841 EV kits, $V_{CC} = +2.7V$ to $+3.6V$, $GND = 0V$, $\overline{SHDN} = V_{CC}$, $V_{DAC} = 1.6V$ (MAX2840), $V_{DAC} = 1.9V$ (MAX2841), $T_A = +25^\circ C$. Typical values are measured at $V_{CC} = +3.3V$, $f_{RF} = 5.25GHz$, unless otherwise noted.) (Note 2)

MAX2840/MAX2841

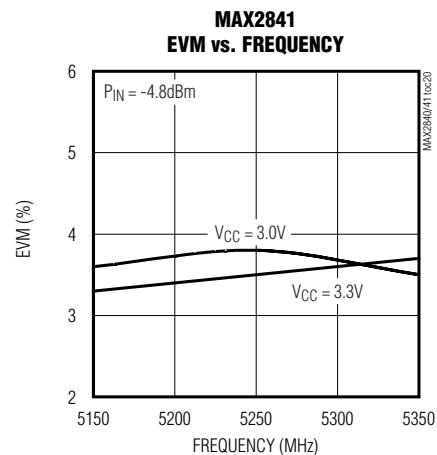
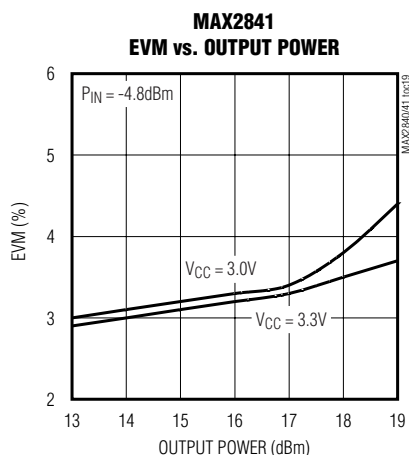
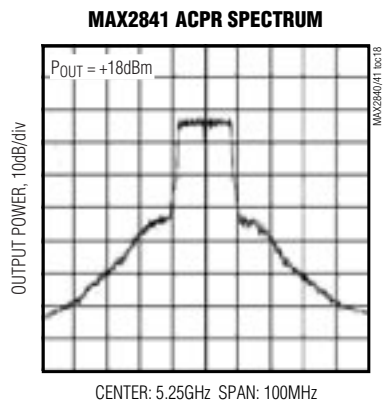
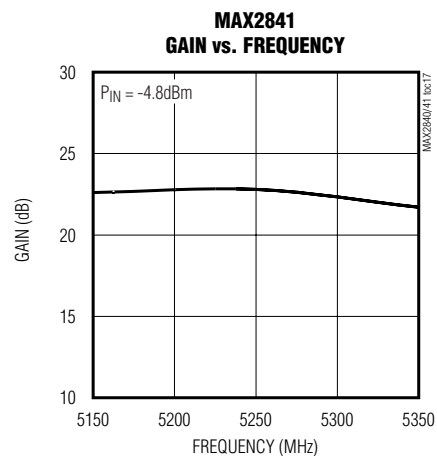
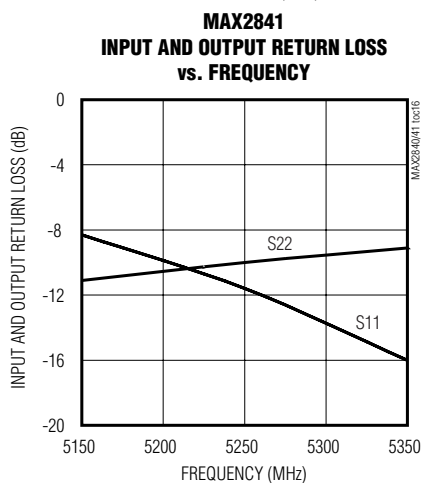
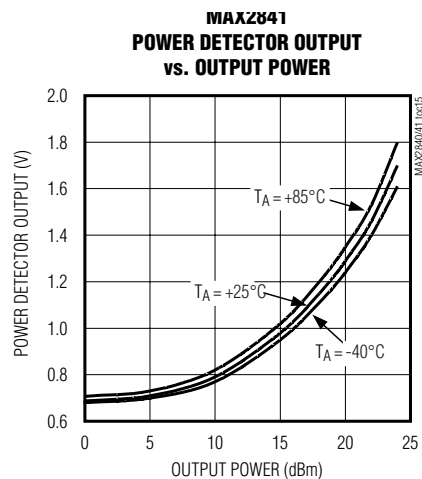
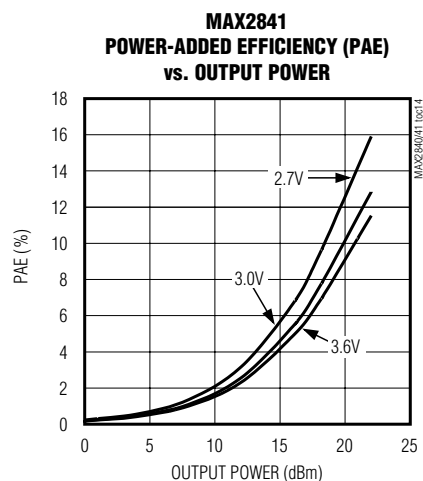
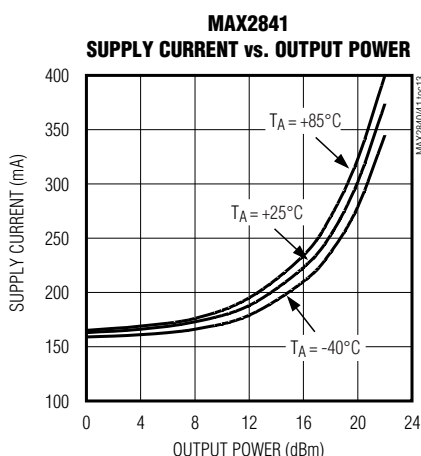
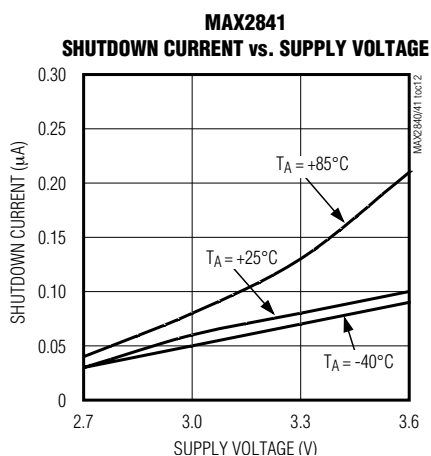

5GHz Linear Power Amplifiers

Pin Description

PIN	NAME	DESCRIPTION
A1	$\overline{\text{SHDN}}$	Shutdown Input. Drive logic low to place the PA in shutdown mode; drive logic high for normal operation.
A2, A4, C2, C4	GND	Ground. Requires a good connection to the circuit board ground plane with multiple vias for lowest possible inductance and lowest thermal resistance.
A3	V _{CC}	DC Supply Voltage. Requires external RF bypass capacitor to ground.
B2	RF_IN	Power Amplifier Input. Requires external DC-blocking capacitor.
B4	RF_OUT	Power Amplifier Output. Requires external DC-blocking capacitor and pullup inductor.
C1	BIAS	Bias Control. Connect two external resistors and DAC block to adjust the bias current.
C3	P_DET	Power Detector Output. This output is a DC voltage indicating the PA output power.

Detailed Description

The MAX2840/MAX2841 linear power amplifiers (PAs) are intended for 5GHz to 6GHz band applications. The PAs are fully characterized in the 5.15GHz to 5.35GHz band. The PAs consist of two driver stages and an output stage. The ICs also feature an integrated power detector and power shutdown mode.

Dynamic Power Control

The MAX2840/MAX2841 are designed to provide optimum power-added efficiency (PAE) in both high- and low-power applications. For a +3.3V supply at high-output power level, the output power is typically +18dBm (MAX2841) with an idle current of 165mA, or +15dBm (MAX2840) with an idle current of 120mA. At low-output power levels, the DC current can be reduced by an external DAC to improve PAE while maintaining sufficient ACPR performance. This is achieved by using external resistors connected to the BIAS pin to set the bias currents of the driver and output stages. See the *Typical Application Circuit* for resistor values. Typically, a DAC voltage of 1.9V gives a 260mA bias current for the MAX2841, a DAC voltage of 1.6V gives a 155mA bias current for the MAX2840. Increasing the DAC voltage decreases the idle current. Similarly, decreasing the DAC voltage increases the idle current. Users can set the desired idle current using only two off-chip 1% resistors: a shunt resistor (R2) from BIAS to ground and a series resistor (R1) to the DAC voltage, as shown in the *Typical Application Circuit*. Resistor values R1 and R2 are determined as follows:

[Equation 1]

$$V_{\text{MAX}} = 1.2 \times (R1 + R2) / R2;$$

$$(I_{\text{CC}} = 0, V_{\text{DAC}} = V_{\text{MAX}})$$

[Equation 2]

$$I_{\text{MAX}} = \text{PART} \times 1.2 / 2000 + (R1 \times R2) / (R1 + R2);$$

$$(I_{\text{CC}} = I_{\text{MAX}} = \text{max value}, V_{\text{DAC}} = 0)$$

[Equation 3]

$$I_{\text{DAC}} = (V_{\text{DAC}} - 0.82) / R1$$

[Equation 4]

$$I_{\text{MID}} = \text{PART} \times 1.2 / (2000 + R2);$$

$$(V_{\text{DAC}} = \text{floating})$$

[Equation 5]

$$I_{\text{CC}} = \text{PART} \times I_{\text{BIAS}}$$

where:

V_{MAX} = maximum DAC voltage

I_{MAX} = maximum idle current

I_{MID} = idle current with V_{DAC} = floating

V_{DAC} = DAC voltage

I_{DAC} = DAC current

PART = 1000 for MAX2840, 1600 for MAX2841

If no DAC is used and a constant idle current is desired, use Equation 4 to determine the resistor values for a given total bias current. Only R2 is required.

For a DAC capable of sourcing and sinking currents, the full voltage range of the DAC (typically from 0 to +3V) can be used. By substituting the desired values of V_{MAX} and I_{MAX} into Equations 1 and 2, R1 and R2 can be easily calculated.

For a DAC capable of sourcing current only, use Equation 4 to determine the value of resistor R2 for the desired maximum current. Use Equation 1 to determine the value of resistor R1 for the desired minimum current.

5GHz Linear Power Amplifiers

For a DAC capable of sinking current only, set resistors R1 and R2 to 0 and connect the DAC directly to the BIAS pin. Use Equation 5 to determine the DAC current required for a given ICC.

Shutdown Mode

Apply logic low to $\overline{\text{SHDN}}$ (pin A1) to put the MAX2840/MAX2841 in shutdown mode. In this mode, all gain stages are disabled and supply current drops to less than 10 μ A. Note that the shutdown current is lowest when $V_{\text{SHDN}} = 0$.

Power Detector

The power detector generates a voltage proportional to the output power. It is fully temperature compensated and allows the user to set the bandwidth with an external capacitor. For maximum bandwidth, connect a 100k Ω resistor from P_DET to GND and do not use any external capacitors.

Applications Information

Supply Bypassing

VCC provides bias to the first- and second-stage amplifiers. See the *Typical Application Circuit* for the lumped and discrete component values used on the MAX2840/MAX2841 EV kits for optimum RF bypassing. In addition to RF bypass capacitors on each bias line, a global bypass capacitor of 10 μ F is necessary to filter any noise on the supply line. Route separate VCC bias paths from the global bypass capacitor (star topology) to avoid coupling between PA stages. Use the MAX2840/MAX2841 EV kits PC board layout as a guide.

External Matching

The RFIN port requires a matching network. The RFIN port impedance is $11 + j14\Omega$ at 5.25GHz. See the *Typical Application Circuit* for recommended component values. The RFOUT port is an open-collector output that must be pulled to VCC through a 5.6nH RF choke for proper biasing. Two shunt capacitors to ground are required at the supply side of the inductor. In addition, a matching network is required for optimum gain, efficiency, ACPR, and output power. The load impedance seen at the RFOUT port of the MAX2840/MAX2841 on the EV kits is approximately $13 + j5\Omega$. This should serve as a good starting point for the layout. However, optimum performance is layout dependent and some component optimization may be required. See the *Typical Application Circuit* for the lumped and discrete component values used on the MAX2840/MAX2841 EV kits to achieve this impedance.

Ground Vias

Placement and type of ground vias are important to achieve optimum gain and output power and ACPR performance. Each ground pin requires its own via on pad (via diameter = 8 mils) placed under the device pin to reduce ground inductance and feedback between stages. Use the MAX2840/MAX2841 EV kit PC board layouts as a guide.

Layout and Thermal Management Issues

The MAX2840/MAX2841 EV kits serve as a layout guide. Use controlled-impedance lines on all high-frequency inputs and outputs. The GND pins also serve as heatsinks. Connect all GND pins directly to the top-side RF ground. On boards where the ground plane is not on the component side, connect all GND pins to the ground plane with plated multiple through holes close to the package. PC board traces connecting the GND pins also serve as heatsinks. Make sure the traces are sufficiently wide.

UCSP Reliability

The chip-scale package (UCSP) is a unique package that greatly reduces board space. UCSP reliability is integrally linked to the user's assembly methods, circuit board material, and usage environment. The user should closely review these areas when considering using a UCSP. This form factor might not perform equally to a packaged product through traditional mechanical reliability tests. Performance through operating life test and moisture resistance remains uncompromised, as it is primarily determined by the wafer-fabrication process.

Mechanical stress performance is a greater consideration for a UCSP. UCSP solder-joint contact integrity must be considered because the package is attached through direct solder contact to the user's PC board. Testing to characterize the UCSP reliability performance shows that it is capable of performing reliably through environmental stresses. Results of environmental stress tests and additional usage data and recommendations are detailed in the UCSP application note, which can be found on Maxim's website, www.maxim-ic.com.

Users should be aware that, as with any interconnect system, there are electromigration-based current limits, which in this case apply to the maximum allowable current in the bumps. Reliability is a function of this current, the duty cycle, lifetime, and bump temperature. See the *Absolute Maximum Ratings* section of the data sheet for any specific limitation, listed under "Continuous Operating Lifetime."

Chip Information

TRANSISTOR COUNT: 1263

5GHz Linear Power Amplifiers

Typical Operating Circuit

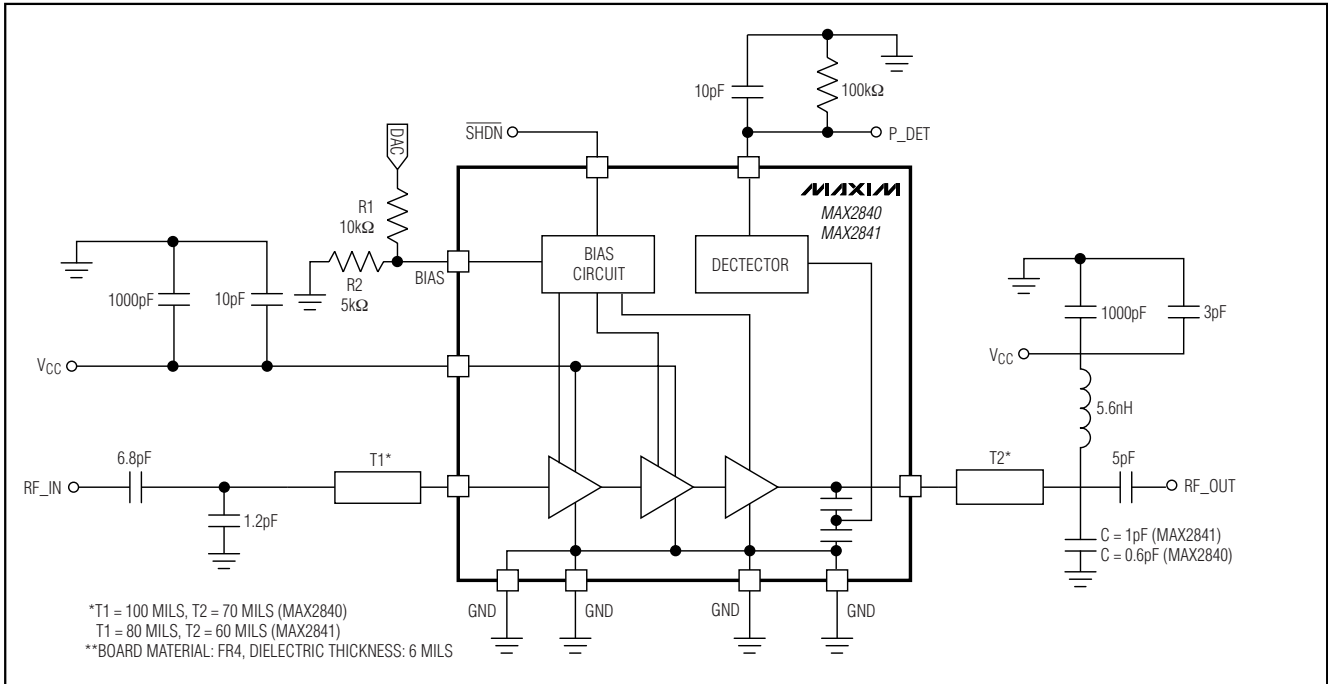

5GHz Linear Power Amplifiers

Package Information

(The package drawing(s) in this data sheet may not reflect the most current specifications. For the latest package outline information go to www.maxim-ic.com/packages.)

MAX2840/MAX2841

TOP VIEW

COMMON DIMENSIONS	
A	0.62±0.05-0.08
A1	0.29±0.02
A2	0.33 REF.
b	ø0.35±0.03
D1	1.00 BASIC
E1	1.50 BASIC
e	0.50 BASIC
SD	0.00 BASIC
SE	0.25 BASIC

PKG. CODE	VARIABLE DIMENSIONS		DEPOPULATED SOLDER BALLS
	D	E	
B12-1	1.54±0.05	2.02±0.05	NONE
B12-2	1.54±0.05	2.02±0.05	B3
B12-3	1.54±0.05	2.12±0.05	NONE
B12-4	1.54±0.05	2.02±0.05	B2, B3
B12-5	1.64±0.05	2.12±0.05	B2
B12-6	1.64±0.05	2.12±0.05	B3
B12-7	1.54±0.05	2.02±0.05	B1, B3
B12-8	1.54±0.05	2.02±0.05	B2
B12-9	1.54±0.05	2.12±0.05	B2, B3
B12-10	1.54±0.05	2.02±0.05	B1, B2, B3, B4
B12-11	1.54±0.05	2.02±0.05	A2, C3

NOTES:

- ALL DIMENSIONS ARE IN MILLIMETERS.
- PRODUCT MARKING: NUMBER OF CHARACTERS AND LINES VARY PER PRODUCT.

BOTTOM VIEW

SIDE VIEW

PROPRIETARY INFORMATION	
TITLE PACKAGE OUTLINE, 4x3 UCSP	
APPROVAL	DOCUMENT CONTROL NO. 21-0104
REV. F	1/1

12L UCSP 4x3.EPS

Maxim cannot assume responsibility for use of any circuitry other than circuitry entirely embodied in a Maxim product. No circuit patent licenses are implied. Maxim reserves the right to change the circuitry and specifications without notice at any time.