



4.5Ω Dual SPST Analog Switches in UCSP

General Description

The MAX4721/MAX4722/MAX4723 low-voltage, low on-resistance (R_{ON}), dual single-pole/single throw (SPST) analog switches operate from a single +1.8V to +5.5V supply. These devices are designed for USB 1.1 and audio switching applications.

The MAX4721/MAX4722/MAX4723 feature 4.5Ω R_{ON} (max) with 1.2Ω flatness and 0.3Ω matching between channels. These new switches feature guaranteed operation from +1.8V to +5.5V and are fully specified at 3V and 5V. These switches offer break-before-make switching (1ns) with t_{ON} <80ns and t_{OFF} <40ns at +2.7V. The digital logic inputs are +1.8V logic compatible with a +2.7V to +3.6V supply.

These switches are packaged in a chip-scale package (UCSP™), significantly reducing the required PC board area. The chip occupies only a 1.52mm × 1.52mm area and has a 3 × 3 bump array with a bump pitch of 0.5mm. These switches are also available in an 8-pin μMAX package.

Applications

- Battery-Operated Equipment
- Audio/Video-Signal Routing
- Low-Voltage Data-Acquisition Systems
- Sample-and-Hold Circuits
- Communications Circuits

Rail-to-Rail is a registered trademark of Nippon Motorola, Ltd.
UCSP is a trademark of Maxim Integrated Products, Inc.

Features

- ◆ USB 1.1 Signal Switching
- ◆ <2ns Differential Skew
- ◆ -3dB Bandwidth: >300MHz
- ◆ Low 15pF On-Channel Capacitance
- ◆ Low R_{ON} (max) Switches
4.5Ω (max) (+3V Supply)
3Ω (max) (+5V Supply)
- ◆ 0.3Ω (max) R_{ON} Match (+3V Supply)
- ◆ 1.2Ω (max) R_{ON} Flatness (+3V Supply)
- ◆ <0.5nA Leakage Current at $T_A = +25^\circ\text{C}$
- ◆ High Off-Isolation: -55dB (10MHz)
- ◆ Low Crosstalk: -80dB (10MHz)
- ◆ Low Distortion: 0.03%
- ◆ +1.8V CMOS-Logic Compatible
- ◆ Single-Supply Operation from +1.8V to +5.5V
- ◆ Rail-to-Rail® Signal Handling

Ordering Information

PART	TEMP RANGE	PIN/BUMP-PACKAGE	TOP MARK
MAX4721EUA	-40°C to +85°C	8 μMAX	—
MAX4721EBL-T*	-40°C to +85°C	9 UCSP-9	ABP
MAX4722EUA	-40°C to +85°C	8 μMAX	—
MAX4722EBL-T*	-40°C to +85°C	9 UCSP-9	ABQ
MAX4723EUA	-40°C to +85°C	8 μMAX	—
MAX4723EBL-T*	-40°C to +85°C	9 UCSP-9	ABR

Note: UCSP package requires special solder temperature profile described in the Absolute Maximum Ratings section.

*UCSP reliability is integrally linked to the user's assembly methods, circuit board material, and environment. See the UCSP reliability notice in the UCSP Reliability section of this data sheet for more information.

Pin Configurations/Functional Diagrams/Truth Tables

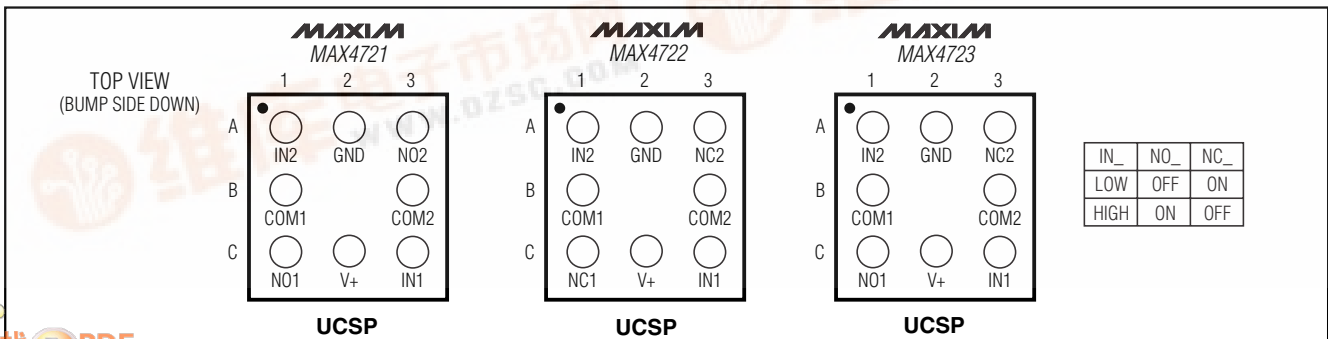

MAX4721/MAX4722/MAX4723

4.5Ω Dual SPST Analog Switches in UCSP

ABSOLUTE MAXIMUM RATINGS

(All Voltages Referenced to GND, Unless Otherwise Noted.)

V+, IN_	-0.3V to +6.0V
COM_, NO_, NC_ (Note 1)	-0.3V to (V+ + 0.3V)
Continuous Current COM_, NO_, NC_	±100mA
Peak Current COM_, NO_, NC_ (pulsed at 1ms, 10% duty cycle)	±200mA
Continuous Power Dissipation (T _A = +70°C)	
8-Pin μMAX (derate 4.5mW/°C above +70°C)	362mW
9-Bump UCSP (derate 4.7mW/°C above +70°C)	379mW

ESD Method 3015.7	>2kV
Operating Temperature Range	-40°C to +85°C
Junction Temperature	+150°C
Storage Temperature Range	-65°C to +150°C
Lead Temperature (soldering, 10s)	+300°C
Bump Temperature (soldering) (Note 2)	
Infrared (15s)	+220°C
Vapor Phase (60s)	+215°C

Note 1: Signals on COM_, NO_, or NC_ exceeding V+ or GND are clamped by internal diodes. Limit forward-diode current to maximum current rating.

Note 2: This device is constructed using a unique set of packaging techniques that impose a limit on the thermal profile the device can be exposed to during board level solder attach and rework. This limit permits only the use of the solder profiles recommended in the industry standard specification, JEDEC 020A, paragraph 7.6, table 3 for IR/VPR and convection reflow. Preheating is required. Hand or wave soldering is not allowed.

Stresses beyond those listed under "Absolute Maximum Ratings" may cause permanent damage to the device. These are stress ratings only, and functional operation of the device at these or any other conditions beyond those indicated in the operational sections of the specifications is not implied. Exposure to absolute maximum rating conditions for extended periods may affect device reliability.

ELECTRICAL CHARACTERISTICS—Single +3V Supply

(V+ = +2.7V to +3.6V, V_{IH} = +1.4V, V_{IL} = +0.5V, T_A = T_{MIN} to T_{MAX}, unless otherwise noted. Typical values are at V+ = +3.0V, T_A = +25°C, unless otherwise noted.) (Notes 3, 4)

PARAMETER	SYMBOL	CONDITIONS	T _A	MIN	TYP	MAX	UNITS
Analog Signal Range	V _{COM_} , V _{NO_} , V _{NC_}			0		V+	V
ANALOG SWITCH							
On-Resistance (Note 5)	R _{ON}	V+ = 2.7V, I _{COM_} = 10mA; V _{NO_} or V _{NC_} = 1.5V	+25°C	3.0	4.5		Ω
			T _{MIN} to T _{MAX}			5	
On-Resistance Match Between Channels (Notes 5, 6)	ΔR _{ON}	V+ = 2.7V, I _{COM_} = 10mA; V _{NO_} or V _{NC_} = 1.5V	+25°C	0.1	0.3		Ω
			T _{MIN} to T _{MAX}			0.4	
On-Resistance Flatness (Note 7)	R _{FLAT(ON)}	V+ = 2.7V, I _{COM_} = 10mA; V _{NO_} or V _{NC_} = 1.0V, 1.5V, 2.0V	+25°C	0.6	1.2		Ω
			T _{MIN} to T _{MAX}			1.5	
NO_, NC_ Off-Leakage Current (Note 8)	I _{NO_(OFF)} , I _{NC_(OFF)}	V+ = 3.6V, V _{COM_} = 0.3V, 3.3V; V _{NO_} or V _{NC_} = 3.3V, 0.3V	+25°C	-0.5	+0.01	+0.5	nA
			T _{MIN} to T _{MAX}	-1.5		+1.5	
COM_ Off-Leakage Current (Note 8)	I _{COM_(OFF)} , I _{COM_(OFF)}	V+ = 3.6V, V _{COM_} = 0.3V, 3.3V; V _{NO_} or V _{NC_} = 3.3V, 0.3V	+25°C	-0.5	+0.01	+0.5	nA
			T _{MIN} to T _{MAX}	-1.5		+1.5	
COM_ On-Leakage Current (Note 8)	I _{COM_(ON)}	V+ = 3.6V, V _{COM_} = 0.3V, 3.3V; V _{NO_} or V _{NC_} = 0.3V, 3.3V, or floating	+25°C	-1	+0.01	+1	nA
			T _{MIN} to T _{MAX}	-2		+2	
Turn-On Time	t _{ON}	V _{NO_} , V _{NC_} = 1.5V; R _L = 300Ω, C _L = 35pF, Figure 1	+25°C	40	80		ns
			T _{MIN} to T _{MAX}			100	

4.5Ω Dual SPST Analog Switches in UCSP

ELECTRICAL CHARACTERISTICS—Single +3V Supply (continued)

(V+ = +2.7V to +3.6V, V_{IH} = +1.4V, V_{IL} = +0.5V, T_A = T_{MIN} to T_{MAX}, unless otherwise noted. Typical values are at V+ = +3.0V, T_A = +25°C, unless otherwise noted.) (Notes 3, 4)

PARAMETER	SYMBOL	CONDITIONS	T _A	MIN	TYP	MAX	UNITS
DYNAMIC CHARACTERISTICS							
Turn-Off Time	t _{OFF}	V _{NO_} , V _{NC_} = 1.5V; R _L = 300Ω, C _L = 35pF, Figure 1	+25°C	20	40		ns
			T _{MIN} to T _{MAX}			50	
Break-Before-Make Time Delay (MAX4723 Only) (Note 8)	t _{BBM}	V _{NO_} , V _{NC_} = 1.5V; R _L = 300Ω, C _L = 35pF, Figure 2	+25°C	8			ns
			T _{MIN} to T _{MAX}	1			
Skew (Note 8)	t _{SKEW}	R _S = 39Ω, C _L = 50pF, Figure 3	T _{MIN} to T _{MAX}	0.15	0.2		ns
Charge Injection	Q	V _{GEN} = 2V, R _{GEN} = 0Ω, C _L = 1.0nF, Figure 4	+25°C		5		pC
Off-Isolation (Note 9)	V _{ISO}	f = 10MHz; V _{NO_} , V _{NC_} = 1VP-P; R _L = 50Ω, C _L = 5pF, Figure 5a	+25°C		-55		dB
				f = 1MHz; V _{NO_} , V _{NC_} = 1VP-P; R _L = 50Ω, C _L = 5pF, Figure 5a		-80	
Crosstalk (Note 10)	V _{CT}	f = 10MHz; V _{NO_} , V _{NC_} = 1VP-P; R _L = 50Ω, C _L = 5pF, Figure 5b	+25°C		-80		dB
				f = 1MHz; V _{NO_} , V _{NC_} = 1VP-P; R _L = 50Ω, C _L = 5pF, Figure 5b		-110	
On-Channel -3dB Bandwidth	BW	Signal = 0dBm, C _L = 5pF, R _L = 50Ω, Figure 5a	+25°C		>300		MHz
Total Harmonic Distortion	THD	R _L = 600Ω	+25°C		0.03		%
NO_, NC_ Off-Capacitance	C _{NO_(OFF)} C _{NC_(OFF)}	f = 1MHz, Figure 6	+25°C		9		pF
Switch On-Capacitance	C _(ON)	f = 1MHz, Figure 6	+25°C		15		pF
DIGITAL I/O							
Input Logic High Voltage	V _{IH}		T _{MIN} to T _{MAX}	1.4			V
Input Logic Low Voltage	V _{IL}		T _{MIN} to T _{MAX}			0.5	V
Input Leakage Current	I _{IN}	V+ = +3.6V, V _{IN_} = 0 or 5.5V	T _{MIN} to T _{MAX}	-0.1		+0.1	μA
SUPPLY							
Supply Voltage Range	V+		T _{MIN} to T _{MAX}	1.8		5.5	V
Positive Supply Current	I+	V+ = 5.5V, V _{IN_} = 0V or V+	T _{MIN} to T _{MAX}			1	μA

MAX4721/MAX4722/MAX4723

4.5Ω Dual SPST Analog Switches in UCSP

ELECTRICAL CHARACTERISTICS—Single +5V Supply

(V+ = +4.2V to +5.5V, V_{IH} = +2.0V, V_{IL} = +0.8V, T_A = T_{MIN} to T_{MAX}, unless otherwise noted. Typical values are at V+ = +5.0V, T_A = +25°C, unless otherwise noted.) (Notes 3, 4)

PARAMETER	SYMBOL	CONDITIONS	T _A	MIN	TYP	MAX	UNITS
Analog Signal Range	V _{COM_} , V _{NO_} , V _{NC_}		T _{MIN} to T _{MAX}	0		V+	V
ANALOG SWITCH							
On-Resistance (Note 5)	R _{ON}	V+ = 4.2V, I _{COM_} = 10mA; V _{NO_} or V _{NC_} = 3.5V	+25°C		1.7	3.0	Ω
			T _{MIN} to T _{MAX}			3.5	
On-Resistance Match Between Channels (Notes 5, 6)	ΔR _{ON}	V+ = 4.2V, I _{COM_} = 10mA; V _{NO_} or V _{NC_} = 3.5V	+25°C		0.1	0.3	Ω
			T _{MIN} to T _{MAX}			0.4	
On-Resistance Flatness (Note 7)	R _{FLAT(ON)}	V+ = 4.2V, I _{COM_} = 10mA; V _{NO_} or V _{NC_} = 1.0V, 2.0V, 3.5V	+25°C		0.4	1.2	Ω
			T _{MIN} to T _{MAX}			1.5	
NO_, NC_ Off-Leakage Current (Note 8)	I _{NO_(OFF)} , I _{NC_(OFF)}	V+ = 5.5V, V _{COM_} = 1.0V, 4.5V; V _{NO_} or V _{NC_} = 4.5V, 1.0V	+25°C	-0.5	+0.01	+0.5	nA
			T _{MIN} to T _{MAX}	-1.5		+1.5	
COM_ Off-Leakage Current (Note 8)	I _{COM_(OFF)}	V+ = 5.5V, V _{COM_} = 1V, 4.5V; V _{NO_} or V _{NC_} = 4.5V, 1V	+25°C	-0.5	+0.01	+0.5	nA
			T _{MIN} to T _{MAX}	-1.5		+1.5	
COM_ On-Leakage Current (Note 8)	I _{COM_(ON)}	V+ = 5.5V, V _{COM_} = 1.0V, 4.5V; V _{NO_} or V _{NC_} = 1.0V, 4.5V, or floating	+25°C	-1	+0.01	+1	nA
			T _{MIN} to T _{MAX}	-2		+2	
DYNAMIC CHARACTERISTICS							
Turn-On Time	t _{ON}	V _{NO_} , V _{NC_} = 3.0V; R _L = 300Ω, C _L = 35pF, Figure 1	+25°C		30	80	ns
			T _{MIN} to T _{MAX}			90	
Turn-Off Time	t _{OFF}	V _{NO_} , V _{NC_} = 3.0V; R _L = 300Ω, C _L = 35pF, Figure 1	+25°C		20	40	ns
			T _{MIN} to T _{MAX}			50	
Break-Before-Make Time Delay (MAX4723 Only) (Note 8)	t _{BBM}	V _{NO_} , V _{NC_} = 3.0V; R _L = 300Ω, C _L = 35pF, Figure 2	+25°C		8		ns
			T _{MIN} to T _{MAX}	1			
Skew (Note 8)	t _{SKEW}	R _S = 39Ω, C _L = 50pF, Figure 3	T _{MIN} to T _{MAX}		1.5	2	ns
DIGITAL I/O							
Input Logic High Voltage	V _{IH}		T _{MIN} to T _{MAX}	2.0			V
Input Logic Low Voltage	V _{IL}		T _{MIN} to T _{MAX}			0.8	V

4.5Ω Dual SPST Analog Switches in UCSP

ELECTRICAL CHARACTERISTICS—Single +5V Supply (continued)

(V+ = +4.2V to +5.5V, V_{IH} = +2.0V, V_{IL} = +0.8V, T_A = T_{MIN} to T_{MAX}, unless otherwise noted. Typical values are at V+ = +5.0V, T_A = +25°C, unless otherwise noted.) (Notes 3, 4)

PARAMETER	SYMBOL	CONDITIONS	T _A	MIN	TYP	MAX	UNITS
Input Leakage Current	I _{IN}	V+ = 5.5V, V _{IN_} = 0V or V+	T _{MIN} to T _{MAX}	-0.1		+0.1	μA
POWER SUPPLY							
Power-Supply Range	V+		T _{MIN} to T _{MAX}	1.8		5.5	V
Positive Supply Current	I+	V+ = 5.5V, V _{IN_} = 0V or V+	T _{MIN} to T _{MAX}			1	μA

Note 3: UCSP parts are 100% tested at +25°C only, and guaranteed by design over the specified temperature range. μMAX parts are 100% tested at T_{MAX} and guaranteed by design over the specified temperature range.

Note 4: The algebraic convention used in this data sheet is where the most negative value is a minimum and the most positive value is a maximum.

Note 5: Guaranteed by design for UCSP parts.

Note 6: ΔRON = RON(MAX) - RON(MIN).

Note 7: Flatness is defined as the difference between the maximum and minimum value of on-resistance as measured over the specified analog signal ranges.

Note 8: Guaranteed by design.

Note 9: Off-Isolation = 20log₁₀ (V_{COM} / V_{NO}), V_{COM} = output, V_{NO} = input to off switch.

Note 10: Between any two switches.

Typical Operating Characteristics

(T_A = +25°C, unless otherwise noted.)

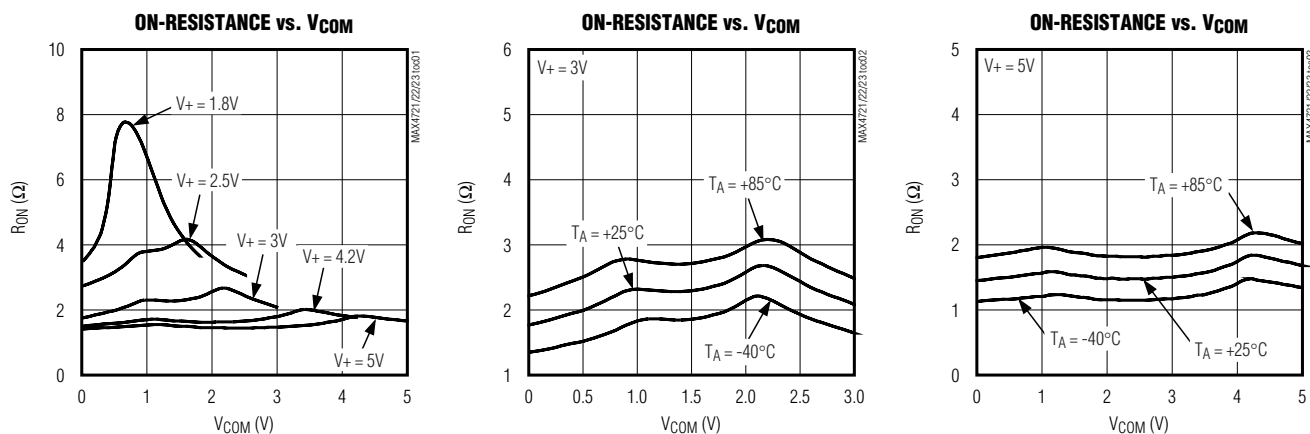

4.5Ω Dual SPST Analog Switches in UCSP

Typical Operating Characteristics (continued)

(T_A = +25°C, unless otherwise noted.)

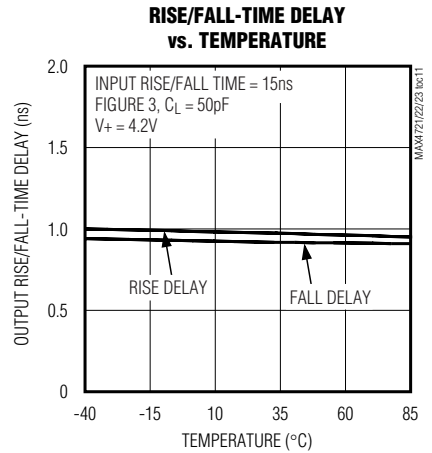
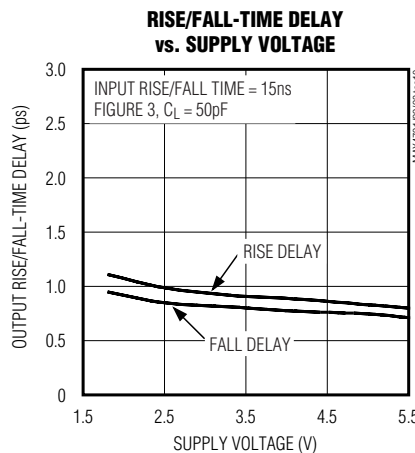
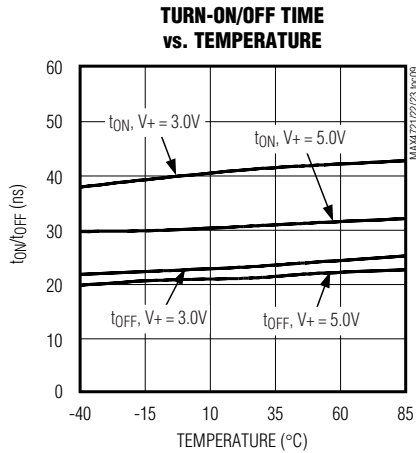
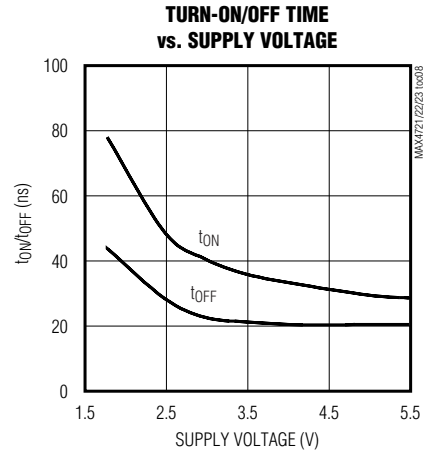
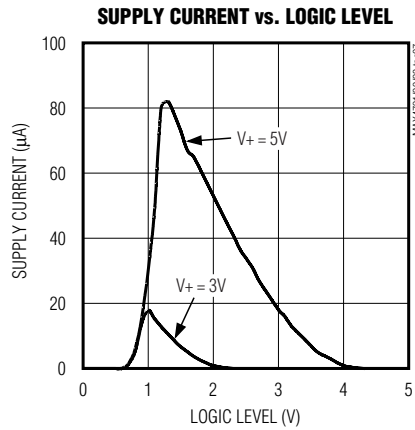
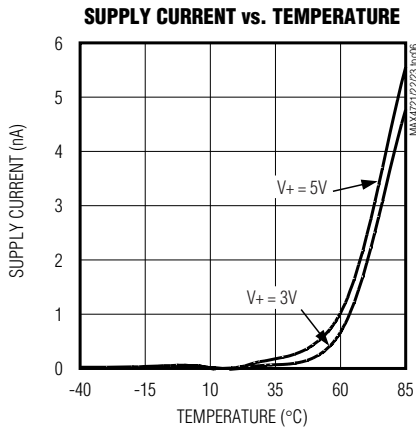
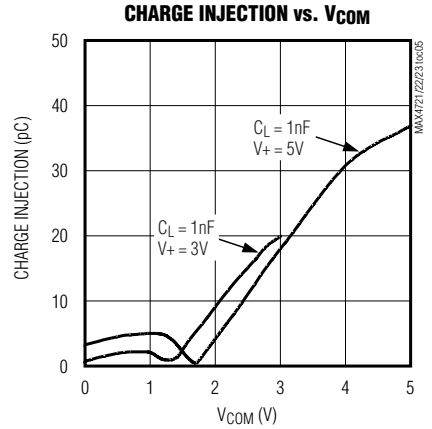
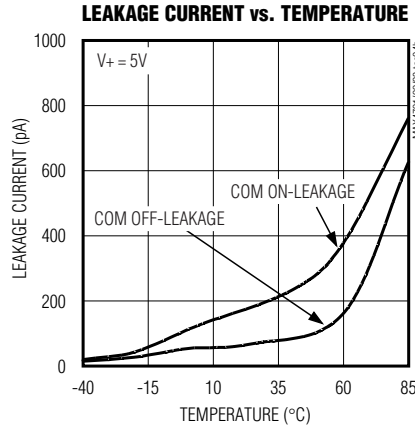
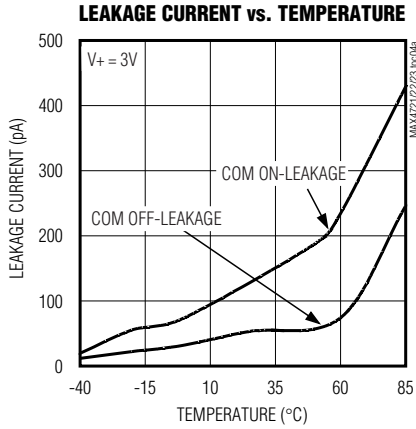

4.5Ω Dual SPST Analog Switches in UCSP

Typical Operating Characteristics (continued)

(T_A = +25°C, unless otherwise noted.)

MAX4721/MAX4722/MAX4723

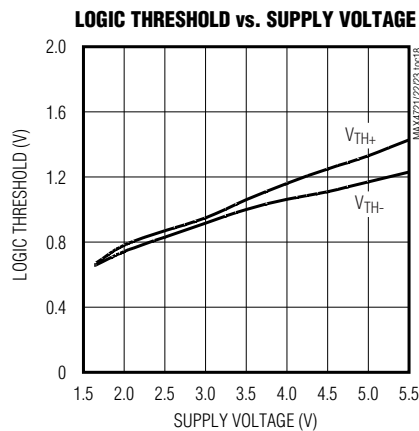
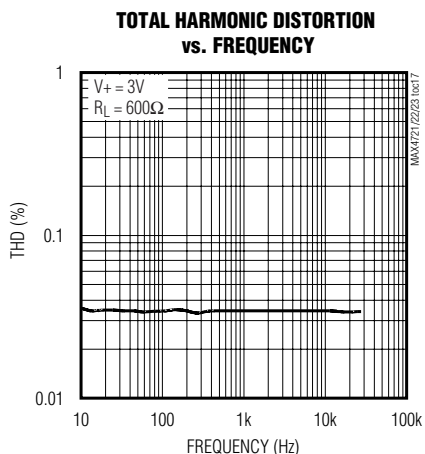
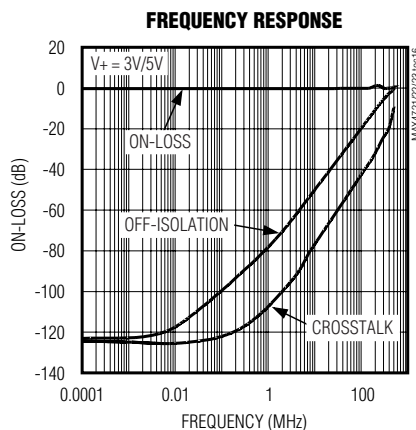
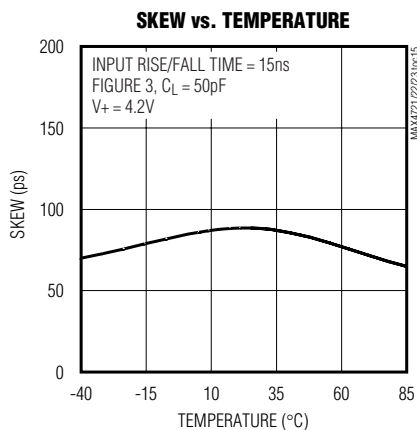
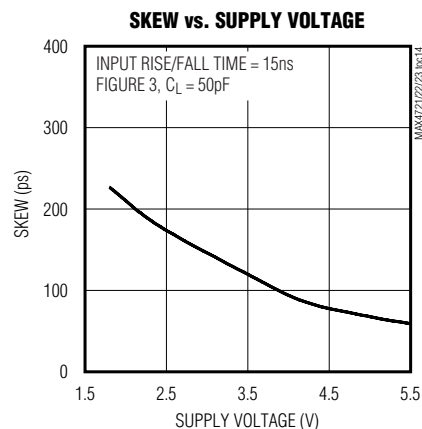
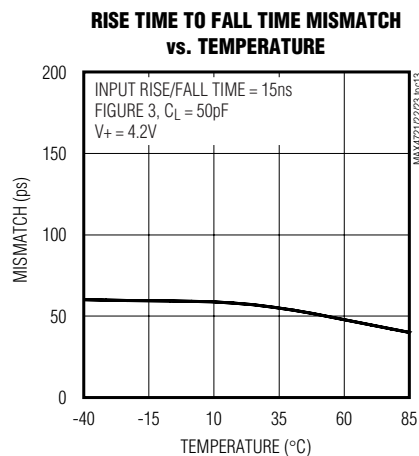
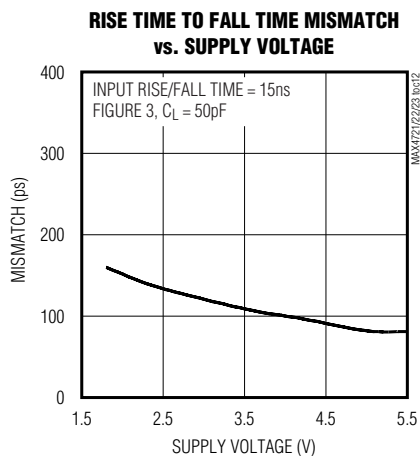

4.5Ω Dual SPST Analog Switches in UCSP

Pin Description

PIN						NAME	FUNCTION
MAX4721		MAX4722		MAX4723			
UCSP	μMAX	UCSP	μMAX	UCSP	μMAX		
A1	3	A1	3	A1	3	IN2	Logic-Control Digital Input
A2	4	A2	4	A2	4	GND	Ground. Connect to digital ground.
A3	5	—	—	—	—	NO2	Analog-Switch Normally Open Terminal
B1	2	B1	2	B1	2	COM1	Analog-Switch Common Terminal
B3	6	B3	6	B3	6	COM2	Analog-Switch Common Terminal
C1	1	—	—	C1	1	NO1	Analog-Switch Normally Open Terminal
C2	8	C2	8	C2	8	V+	Positive Analog Supply
C3	7	C3	7	C3	7	IN1	Logic-Control Digital Input
—	—	C1	1	—	—	NC1	Analog-Switch Normally Closed Terminal
—	—	A3	5	A3	5	NC2	Analog-Switch Normally Closed Terminal

Detailed Description

The MAX4721/MAX4722/MAX4723 dual SPST analog switches operate from a single +1.8V to +5.5V supply. The MAX4721/MAX4722/MAX4723 offer excellent AC characteristics, <0.5nA leakage current, less than 2ms differential skew, and 15pF on-channel capacitance. All of these devices are CMOS-logic compatible with rail-to-rail signal handling capability.

The MAX4721/MAX4722/MAX4723 are USB-compliant switches that provide 4.5Ω (max) on-resistance, and 15pF on-channel capacitance to maintain signal integrity. At 12Mbps (USB full-speed data rate specification) the MAX4721/MAX4722/MAX4723 introduce less than 2ns propagation delay between input and output signals and less than 0.5ns change in skew for the output signals (see Figure 3 for more details).

The MAX4721 has two normally open (NO) switches, the MAX4722 has two normally closed (NC) switches, and the MAX4723 has one NO switch and one NC switch.

Applications Information

Digital Control Inputs

The MAX4721/MAX4722/MAX4723 logic inputs accept up to +5.5V regardless of supply voltage. For example, with a +3.3V supply, IN₁ can be driven low to GND and high to +5.5V allowing for mixing of logic levels in a system. Driving the control logic inputs rail-to-rail minimizes power consumption. For a +3.0V supply voltage, the logic thresholds are 0.5V (low) and 1.4V (high); for a +5V supply voltage, the logic thresholds are 0.8V (low) and 2.0V (high).

Analog Signal Levels

Analog signals that range over the entire supply voltage (V₊ to GND) are passed with very little change in on-resistance (see the *Typical Operating Characteristics*). The switches are bidirectional, so the NO₁, NC₁, and COM₁ pins can be either inputs or outputs.

4.5Ω Dual SPST Analog Switches in UCSP

Test Circuits/Timing Diagrams

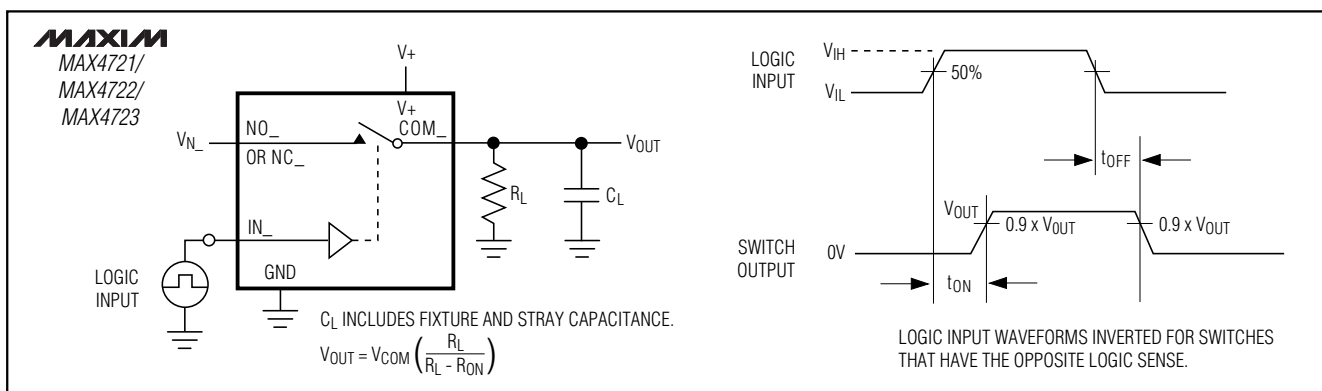

Figure 1. Switching Time

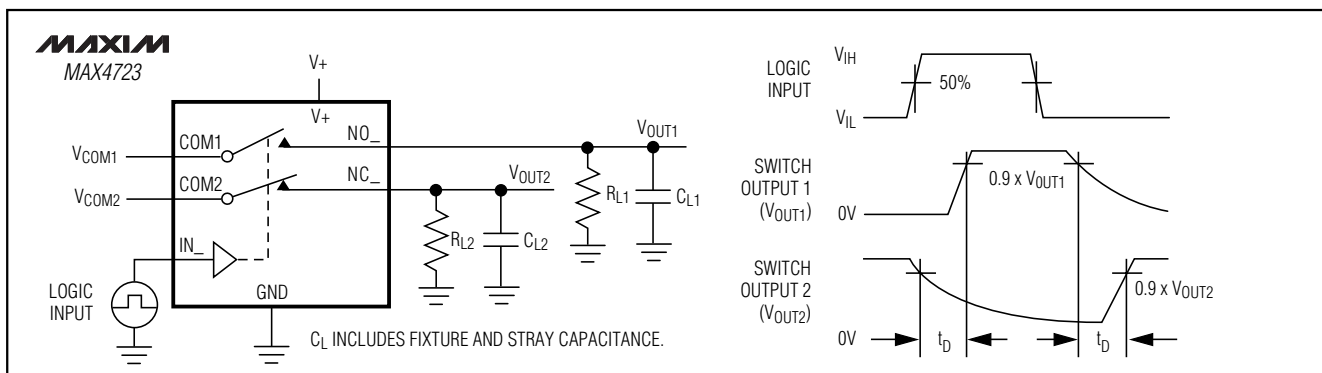

Figure 2. Break-Before-Make Interval

Power-Supply Bypassing

Power-supply bypassing improves noise margin and prevents switching noise from propagating from the V+ supply to other components. A 0.1μF capacitor connected from V+ to GND is adequate for most applications.

Power-Supply Sequencing and Overvoltage Protection

Caution: Do not exceed the absolute maximum ratings because stresses beyond the listed ratings may cause permanent damage to the device.

UCSP Package Considerations

For general UCSP package information and PC layout considerations, please refer to the Maxim Application Note (Wafer-Level Chip-Scale Package).

UCSP Reliability

The chip-scale package (UCSP) represents a unique packaging form factor that may not perform equally to a packaged product through traditional mechanical reliability tests. UCSP reliability is integrally linked to the user's assembly methods, circuit board material, and usage environment. The user should closely review these areas when considering use of a UCSP package. Performance through Operating Life Test and Moisture Resistance remains uncompromised as it is primarily determined by the wafer-fabrication process.

Mechanical stress performance is a greater consideration for a UCSP package. UCSPs are attached through direct solder contact to the user's PC board, foregoing the inherent stress relief of a packaged product lead frame. Solder joint contact integrity must be considered. Information on Maxim's qualification plan, test data, and recommendations are detailed in the UCSP application note, which can be found on Maxim's website at www.maxim-ic.com.

MAX4721/MAX4722/MAX4723

4.5Ω Dual SPST Analog Switches in UCSP

Test Circuits/Timing Diagrams (continued)

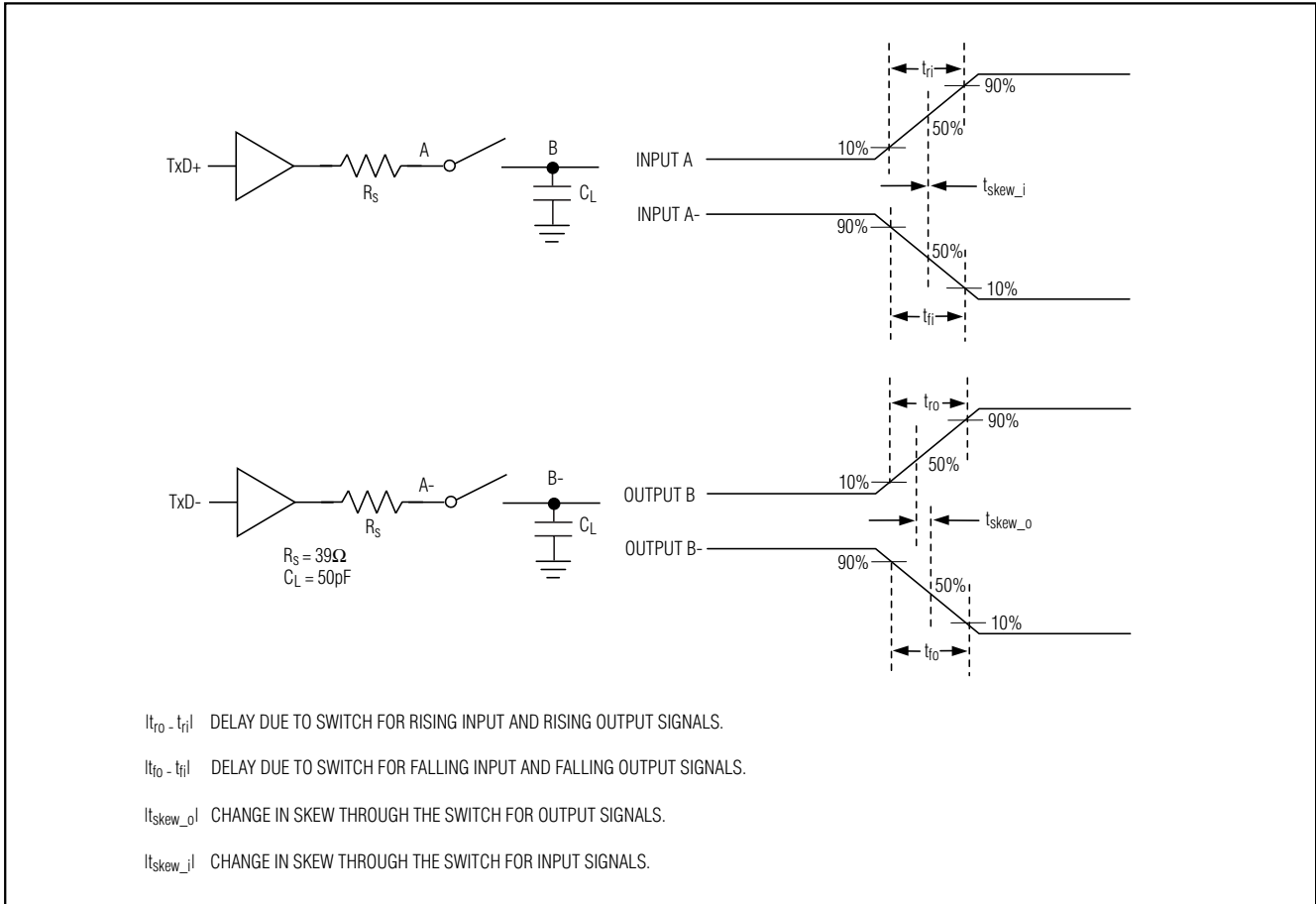

Figure 3. Input/Output Skew Timing Diagram

4.5Ω Dual SPST Analog Switches in UCSP

Test Circuits/Timing Diagrams (continued)

MAX4721/MAX4722/MAX4723

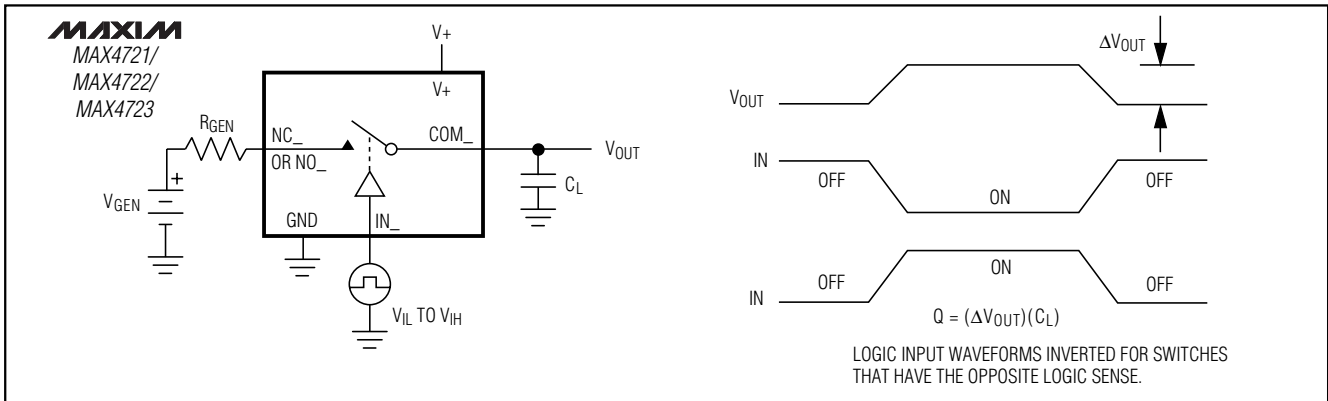

Figure 4. Charge Injection

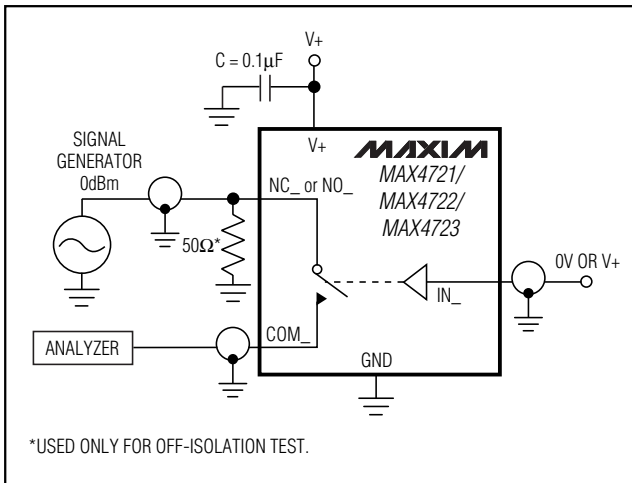

Figure 5a. On-Loss, Off-Isolation, and Crosstalk

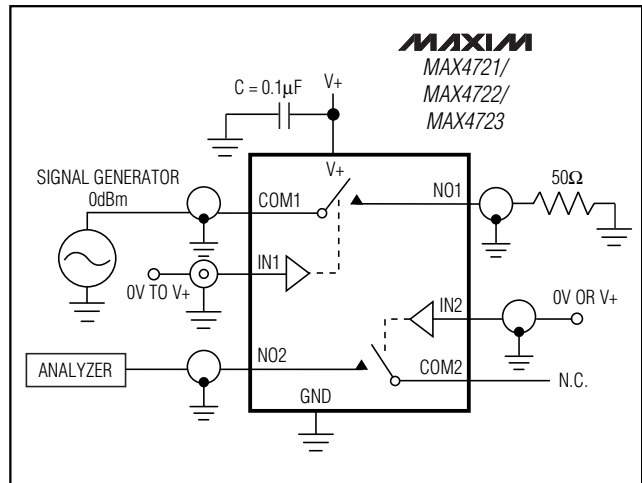

Figure 5b. Crosstalk Test Circuit

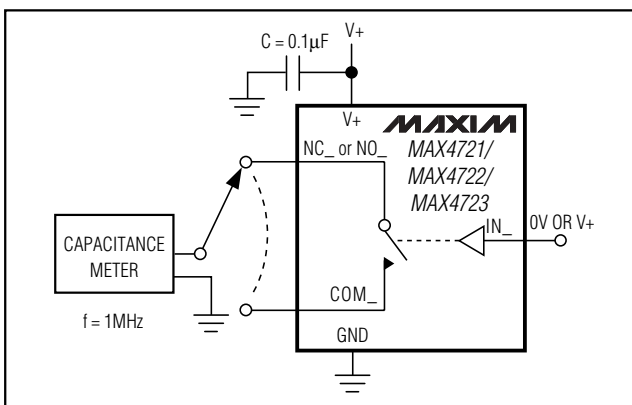

Figure 6. Channel Off/On-Capacitance

Chip Information

TRANSISTOR COUNT: 181

PROCESS: BiCMOS

4.5Ω Dual SPST Analog Switches in UCSP

Pin Configurations/Functional Diagrams/Truth Tables (continued)

TOP VIEW

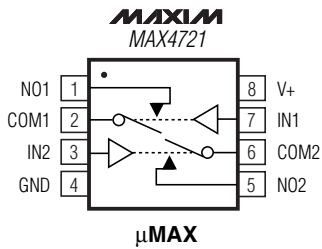

LOGIC	SWITCH
0	OFF
1	ON

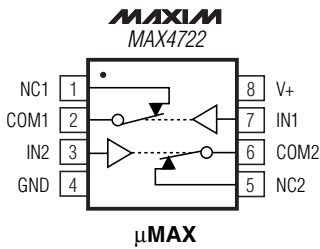

LOGIC	SWITCH
0	ON
1	OFF

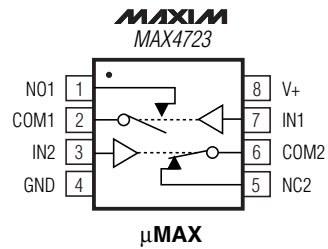

LOGIC	SWITCH1	SWITCH2
0	OFF	ON
1	ON	OFF

SWITCHES SHOWN FOR LOGIC "0" INPUT

4.5Ω Dual SPST Analog Switches in UCSP

Package Information

(The package drawing(s) in this data sheet may not reflect the most current specifications. For the latest package outline information, go to www.maxim-ic.com/packages.)

MAX4721/MAX4722/MAX4723

TOP VIEW

SYMBOL	DIMENSIONS
A	0.60±0.05
D	1.52±0.05
E	1.52±0.05
e	0.50 BASIC
b	∅ 0.35 BASIC
A1	0.27±0.04
A2	0.33 Ref.
hd	0.26 Ref.
he	0.26 Ref.

SOLDER BALL DEPOPULATION	
PKG. CODE	DEPOPULATED BALL
B9-1	NONE
B9-2	B2
B9-3	B1, B2, B3

NOTES:

- ALL DIMENSIONS ARE IN MILLIMETERS.
- MEETS JEDEC M0195.

BOTTOM VIEW

SIDE VIEW

PROPRIETARY INFORMATION

TITLE:
PACKAGE OUTLINE, 3x3 UCSP

APPROVAL	DOCUMENT CONTROL NO. 21-0093	REV. E 1/1
----------	---------------------------------	---------------

4.5Ω Dual SPST Analog Switches in UCSP

Package Information (continued)

(The package drawing(s) in this data sheet may not reflect the most current specifications. For the latest package outline information, go to www.maxim-ic.com/packages.)

TOP VIEW

BOTTOM VIEW

FRONT VIEW

SIDE VIEW

DIM	INCHES		MILLIMETERS	
	MIN	MAX	MIN	MAX
A	-	0.043	-	1.10
A1	0.002	0.006	0.05	0.15
A2	0.030	0.037	0.75	0.95
b	0.010	0.014	0.25	0.36
c	0.005	0.007	0.13	0.18
D	0.116	0.120	2.95	3.05
e	0.0256 BSC		0.65 BSC	
E	0.116	0.120	2.95	3.05
H	0.188	0.198	4.78	5.03
L	0.016	0.026	0.41	0.66
α	0°	6°	0°	6°
S	0.0207 BSC		0.5250 BSC	

NOTES:

- D&E DO NOT INCLUDE MOLD FLASH.
- MOLD FLASH OR PROTRUSIONS NOT TO EXCEED 0.15MM (.006").
- CONTROLLING DIMENSION: MILLIMETERS.
- MEETS JEDEC MO-187C-AA.

DALLAS SEMICONDUCTOR **MAXIM**

PROPRIETARY INFORMATION

TITLE: PACKAGE OUTLINE, 8L uMAX/uSOP

APPROVAL	DOCUMENT CONTROL NO. 21-0036	REV. J 1/1
----------	---------------------------------	------------

8LUMAXD.EPS

Maxim cannot assume responsibility for use of any circuitry other than circuitry entirely embodied in a Maxim product. No circuit patent licenses are implied. Maxim reserves the right to change the circuitry and specifications without notice at any time.