



±15kV ESD-Protected, +5V, 1µA, Single RS-232 Transceiver with AutoShutdown

General Description

The MAX221E is a +5V powered, single transmit/receive RS-232 and V.28 communications interface with automatic shutdown/wake-up features and high data rate capabilities.

The MAX221E features enhanced electrostatic discharge (ESD) protection. Both the transmitter output and receiver input are protected to ±15kV using the IEC 1000-4-2 Air-Gap Discharge Method, to ±8kV using the IEC 1000-4-2 Contact Discharge Method, and to ±15kV using the Human Body Model.

The MAX221E achieves a low 1µA supply current with Maxim's revolutionary AutoShutdown™ feature. AutoShutdown saves power without changes to the existing BIOS or operating system by entering low-power shutdown mode when the RS-232 cable is disconnected or when the transmitter of the connected peripheral is off. The MAX221E wakes up and drives the INVALID pin high when an active RS-232 cable is connected, signaling the host that a peripheral is connected to the communications port.

The MAX221E is available in a 16-pin SSOP package as well as a 16-pin TSSOP that uses 50% less board space than a 16-pin SO.

Applications

- Maintenance/Diagnostic Ports
- Industrial Systems
- Telecommunications
- Set-Top Boxes

Pin Configuration

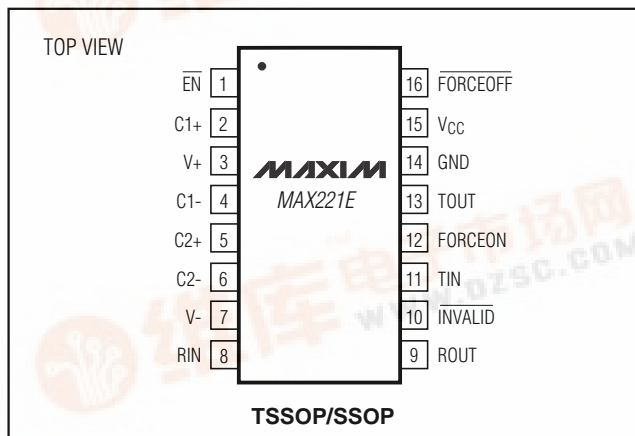

AutoShutdown is a trademark of Maxim Integrated Products.

Features

- ◆ Single RS-232 Transceiver in a Small 16-Pin TSSOP
- ◆ ESD Protection for RS-232 I/O Pins
 - ±15kV—Human Body Model
 - ±8kV—IEC 1000-4-2, Contact Discharge
 - ±15kV—IEC 1000-4-2, Air-Gap Discharge
- ◆ Latchup Free
- ◆ 1µA Supply Current
- ◆ AutoShutdown Saves Power without Changes to BIOS
- ◆ Guaranteed 250kbps Data Rate

Ordering Information

PART	TEMP. RANGE	PIN-PACKAGE
MAX221ECUE	0°C to +70°C	16 TSSOP
MAX221ECAE	0°C to +70°C	16 SSOP
MAX221EEUE	40°C to +85°C	16 TSSOP
MAX221EEAE	40°C to +85°C	16 SSOP

Typical Operating Circuit

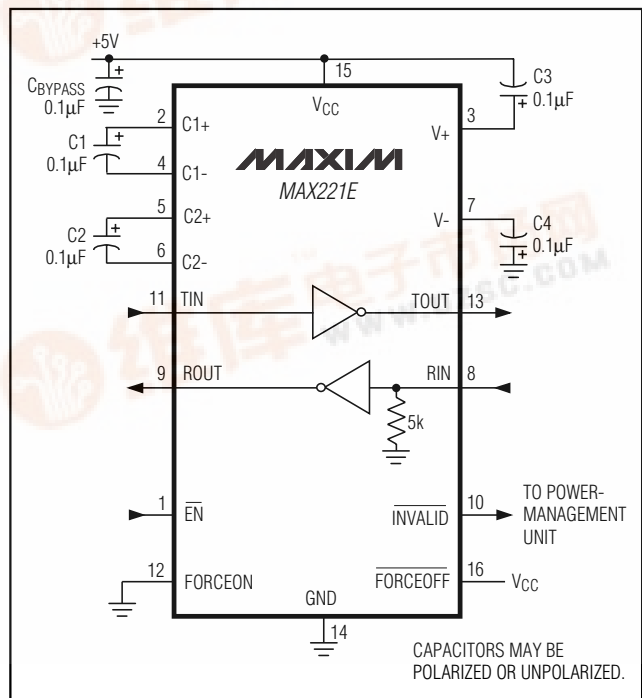

CAPACITORS MAY BE POLARIZED OR UNPOLARIZED.

MAX221E



±15kV ESD-Protected, +5V, 1µA, Single RS-232 Transceiver with AutoShutdown

ABSOLUTE MAXIMUM RATINGS

V _{CC}	-0.3V to +6V	Short-Circuit Duration, T _{OUT}	Continuous
V ₊	(V _{CC} - 0.3V) to +14V	Continuous Power Dissipation (T _A = +70°C)	
V ₋	-14V to +0.3V	16-Pin TSSOP (derated 6.7mW/°C above +70°C)	533mW
Input Voltages		16-Pin SSOP (derated 7.1mW/°C above +70°C)	571mW
T _{IN}	-0.3V to (V ₊ + 0.3V)	Operating Temperature Range	
R _{IN}	±30V	MAX221EC_ _	0°C to +70°C
FORCEON, FORCEOFF, $\overline{\text{EN}}$	-0.3V to (V _{CC} + 0.3V)	MAX221EE_ _	-40°C to +85°C
Output Voltages		Maximum Junction Temperature	+150°C
T _{OUT}	(V ₋ - 0.3V) to (V ₊ + 0.3V)	Storage Temperature Range	-65°C to +150°C
ROUT, INVALID	-0.3V to (V _{CC} + 0.3V)	Lead Temperature (soldering, 10sec)	+300°C

Stresses beyond those listed under "Absolute Maximum Ratings" may cause permanent damage to the device. These are stress ratings only, and functional operation of the device at these or any other conditions beyond those indicated in the operational sections of the specifications is not implied. Exposure to absolute maximum rating conditions for extended periods may affect device reliability.

ELECTRICAL CHARACTERISTICS

(V_{CC} = +5V ±10%, C1–C4 = 0.1µF, T_A = T_{MIN} to T_{MAX}, unless otherwise noted. Typical values are at T_A = +25°C.)

PARAMETER	SYMBOL	CONDITIONS	MIN	TYP	MAX	UNITS
DC CHARACTERISTICS						
V _{CC} Supply Current	I _{CC}	No load, T _A = +25°C		5	10	mA
Shutdown Supply Current	I _{SHDN}	T _A = +25°C, Figure 1		1	10	µA
AutoShutdown Supply Current	I _{AS}			1	10	µA
LOGIC INPUTS						
Input Leakage Current		T _{IN} = 0 to V _{CC}			±1	µA
Input Threshold Low	V _{IL}	T _{IN} , $\overline{\text{EN}}$, FORCEOFF, FORCEON			0.8	V
Input Threshold High	V _{IH}	$\overline{\text{EN}}$, FORCEOFF, T _{IN}	2.4			V
Output Voltage Low	V _{OL}	ROUT; I _{SINK} = 3.2mA			0.4	V
Output Voltage High	V _{OH}	ROUT; I _{SOURCE} = 1.0mA	3.5			V
Output Leakage Current		$\overline{\text{EN}}$ = V _{CC} , 0 ≤ ROUT ≤ V _{CC}		±0.05	±10	µA
AUTOSHUTDOWN						
Receiver Input Threshold, Transmitter Enabled		Figure 3	Positive threshold		2.7	V
			Negative threshold	-2.7		
Receiver Input Threshold, Transmitter Disabled		I _{CC} = 1µA, Figure 3	-0.3		0.3	V
$\overline{\text{INVALID}}$ Output Voltage Low		I _{SINK} = 1.6mA			0.4	V
$\overline{\text{INVALID}}$ Output Voltage High		I _{SOURCE} = 1.0mA	V _{CC} - 0.6			V
Receiver Threshold to Transmitter Enabled	t _{WU}	Figure 3		250		µs
Receiver Positive or Negative Threshold to $\overline{\text{INVALID}}$ High	t _{INVH}	Figure 3		1		µs
Receiver Positive or Negative Threshold to $\overline{\text{INVALID}}$ Low	t _{INVL}	Figure 3		30		µs

$\pm 15\text{kV}$ ESD-Protected, +5V, 1 μA , Single RS-232 Transceiver with AutoShutdown

MAX221E

ELECTRICAL CHARACTERISTICS (continued)

($V_{CC} = +5V \pm 10\%$, $C1-C4 = 0.1\mu\text{F}$, $T_A = T_{MIN}$ to T_{MAX} , unless otherwise noted. Typical values are at $T_A = +25^\circ\text{C}$.)

PARAMETER	SYMBOL	CONDITIONS	MIN	TYP	MAX	UNITS
RECEIVER INPUT						
Input Voltage Range			-25		25	V
Input Threshold Low		$T_A = +25^\circ\text{C}$, $V_{CC} = 5V$	0.8	1.2		V
Input Threshold High		$T_A = +25^\circ\text{C}$, $V_{CC} = 5V$		1.7	2.4	V
Input Hysteresis		$V_{CC} = 5V$, no hysteresis in shutdown		0.5		V
Input Resistance		$T_A = +25^\circ\text{C}$, $V_{CC} = 5V$	3	5	7	$\text{k}\Omega$
TRANSMITTER OUTPUT						
Output Voltage Swing		Driver loaded with $3\text{k}\Omega$ to ground	± 5	± 9		V
Output Resistance		$V_{CC} = V_+ = V_- = 0$, $V_{OUT} = \pm 2V$	300			Ω
Output Short-Circuit Current				± 10	± 60	mA
ESD PROTECTION						
RIN, TOUT		IEC 1000-4-2 Air-Gap Discharge		± 15		kV
		IEC 1000-4-2 Contact Discharge		± 8		
		Human Body Model		± 15		

TIMING CHARACTERISTICS

($V_{CC} = +5V \pm 10\%$, $C1-C4 = 0.1\mu\text{F}$, $T_A = T_{MIN}$ to T_{MAX} , unless otherwise noted. Typical values are at $T_A = +25^\circ\text{C}$.)

PARAMETER	SYMBOL	CONDITIONS	MIN	TYP	MAX	UNITS
Maximum Data Rate		$R_L = 3\text{k}\Omega$ to $7\text{k}\Omega$, $C_L = 50\text{pF}$ to 1000pF , $V_{CC} = 4.5V$	250			kbps
Receiver Propagation Delay	t_{PHL} , t_{PLH}	$C_L = 150\text{pF}$		0.15		ms
Receiver Output Enable Time		Normal operation		300		ns
Receiver Output Disable Time		Normal operation		200		ns
Transmitter Skew	$ t_{PHL} - t_{PLH} $	(Note 1)		200		ns
Receiver Skew	$ t_{PHL} - t_{PLH} $			50		ns
Transition-Region Slew Rate		$T_A = +25^\circ\text{C}$, $V_{CC} = 5V$, $R_L = 3\text{k}\Omega$ to $7\text{k}\Omega$, $C_L = 500\text{pF}$ to 1000pF , measured from $-3V$ to $+3V$ or $+3V$ to $-3V$	3	6	30	$\text{V}/\mu\text{s}$

Note 1: Transmitter skew is measured at the transmitter zero crosspoints.

±15kV ESD-Protected, +5V, 1µA, Single RS-232 Transceiver with AutoShutdown

Typical Operating Characteristics

(V_{CC} = +5V, 250kbps data rate, 0.1µF capacitors, transmitter loaded with 3kΩ and C_L, T_A = +25°C, unless otherwise noted.)

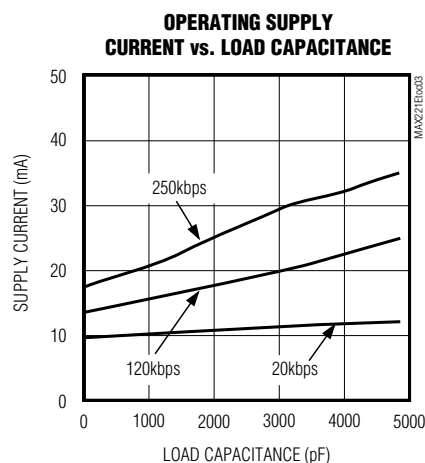
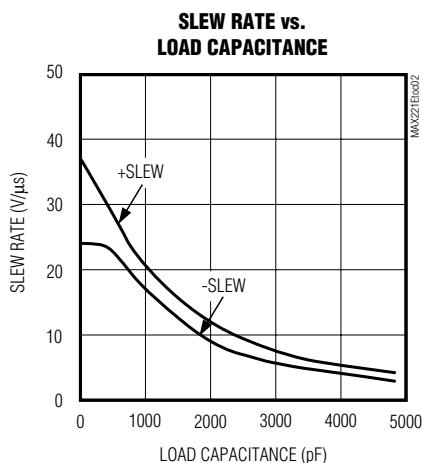
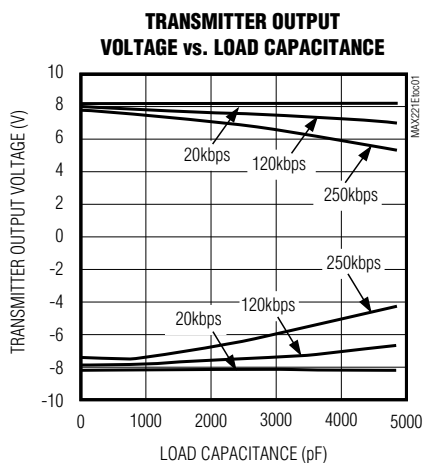

Pin Description

PIN	NAME	FUNCTION
1	$\overline{\text{EN}}$	Receiver Enable Control. Drive low for normal operation. Drive high to force the receiver output (ROUT) into a high-impedance state.
2	C1+	Positive Terminal of the Voltage Doubler Charge-Pump Capacitor
3	V+	Positive Voltage Generated by the Charge Pump
4	C1-	Negative Terminal of the Voltage Doubler Charge-Pump Capacitor
5	C2+	Positive Terminal of the Inverting Charge-Pump Capacitor
6	C2-	Negative Terminal of the Inverting Charge-Pump Capacitor
7	V-	Negative Voltage Generated by the Charge Pump
8	RIN	RS-232 Receiver Input, ±15kV ESD protected
9	ROUT	TTL/CMOS Receiver Output
10	$\overline{\text{INVALID}}$	Output of the Invalid Signal Detector. $\overline{\text{INVALID}}$ is pulled low if no valid RS-232 level is present on the receiver input.
11	TIN	TTL/CMOS Transmitter Input
12	FORCEON	Drive high to override automatic circuitry, keeping transmitter and charge pump on. FORCEOFF must be high (Table 1).
13	TOUT	RS-232 Transmitter Output, ±15kV ESD Protected
14	GND	Ground
15	V _{CC}	+4.5V to +5.5V Supply Voltage
16	$\overline{\overline{\text{FORCEOFF}}}$	Force-Off Input, active low. Drive low to shut down transmitter, receiver, and on-board charge pump. This overrides all automatic circuitry and FORCEON (Table 1).

$\pm 15\text{kV}$ ESD-Protected, +5V, 1 μA , Single RS-232 Transceiver with AutoShutdown

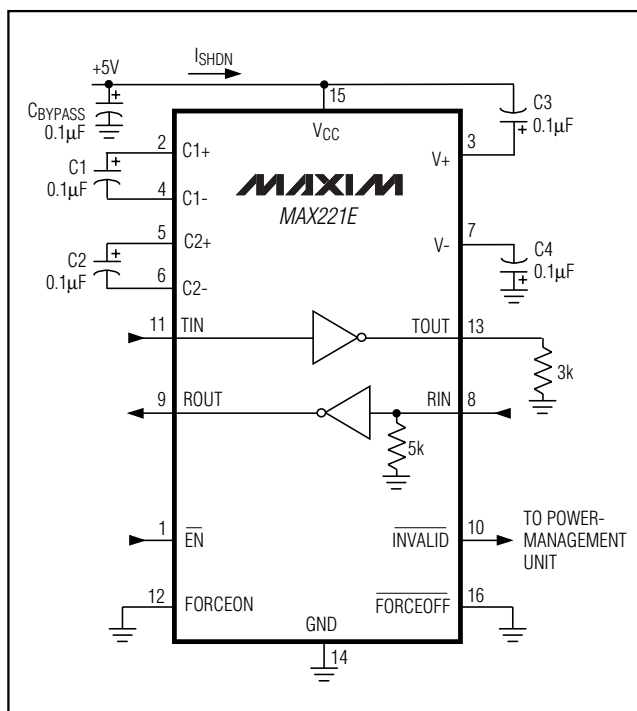

Figure 1. Shutdown Current Test Circuit

Detailed Description

Dual Charge-Pump Voltage Converter

The MAX221E's internal power supply consists of a dual charge pump that provides a positive output voltage (doubling charge pump) and negative output voltage (inverting charge pump) from a single +5V supply. The charge pumps operate in continuous mode. Each charge pump requires a flying capacitor (C1, C2) and a reservoir capacitor (C3, C4) to generate the V+ and V- supplies.

RS-232 Transmitter

The transmitter is an inverting level translator that converts CMOS-logic levels to 5.0V EIA/TIA-232 levels. It guarantees a 250kbps data rate with worst-case loads of 3k Ω in parallel with 1000pF.

When $\overline{\text{FORCEOFF}}$ is driven to ground, or when the AutoShutdown circuitry senses invalid voltage levels on the receiver input, the transmitter is disabled and the output is forced into a high-impedance state. The transmitter input does not have a pull-up resistor.

RS-232 Receiver

The MAX221E's receiver converts RS-232 signals to CMOS-logic output levels. The receiver has an inverting three-state output and can be active or inactive. In shutdown ($\overline{\text{FORCEOFF}} = \text{low}$) or in AutoShutdown, the receiver is active (Table 1). Drive $\overline{\text{EN}}$ high to place the receiver in a high-impedance state. The receiver is high-impedance when the MAX221E is in shutdown ($\overline{\text{FORCEOFF}} = \text{low}$).

The MAX221E's $\overline{\text{INVALID}}$ output is pulled low when there is no valid RS-232 signal level detected on the receiver input. $\overline{\text{INVALID}}$ is functional in any mode (Figures 2 and 3).

AutoShutdown

The MAX221E achieves 1 μA supply current with Maxim's AutoShutdown feature, which operates when $\overline{\text{FORCEON}}$ is low and $\overline{\text{FORCEOFF}}$ is high. When the device senses no valid signal levels on the receiver input for 30 μs , the on-board charge pump and driver are shut off, reducing supply current to 1 μA . This occurs if the RS-232 cable is disconnected or the connected peripheral transmitter is turned off. The MAX221E turns on again when a valid level is applied to the RS-232 receiver input. As a result, the system saves power without changes to the existing BIOS or operating system.

Table 1 and Figure 2c summarize the MAX221E operating modes. $\overline{\text{FORCEON}}$ and $\overline{\text{FORCEOFF}}$ override AutoShutdown. When neither control is asserted, the device selects between these states automatically, based on the receiver input level. Figures 2a, 2b, and 3a depict valid and invalid RS-232 receiver levels. Figure 3 shows the input levels and timing diagram for AutoShutdown operation.

A device or another system with AutoShutdown connected to the MAX221E may need time to wake up. Figure 4 shows a circuit that forces the transmitter on for 100ms, allowing enough time for the other system to realize that the MAX221E is awake. If the other system transmits valid RS-232 signals within that time, the RS-232 ports on both systems remain enabled.

When shut down, the device's charge pumps turn off, V+ is pulled to VCC, V- is pulled to ground, and the transmitter output is high impedance. The time required to exit shutdown is typically 100 μs (Figure 3b).

±15kV ESD-Protected, +5V, 1µA, Single RS-232 Transceiver with AutoShutdown

Table 1. Output Control Truth Table

OPERATION STATUS	FORCEON	FORCEOFF	EN	VALID RECEIVER	TOUT	ROUT
Shutdown (Forced Off)	X	0	0	X	High-Z	Active
	X	0	1	X	High-Z	High-Z
Normal Operation (Forced On)	1	1	0	X	Active	Active
	1	1	1	X	Active	High-Z
Normal Operation (AutoShutdown)	0	1	0	Yes	Active	Active
	0	1	1	Yes	Active	High-Z
Shutdown (AutoShutdown)	0	1	0	No	High-Z	Active
	0	1	1	No	High-Z	High-Z

x = Don't care

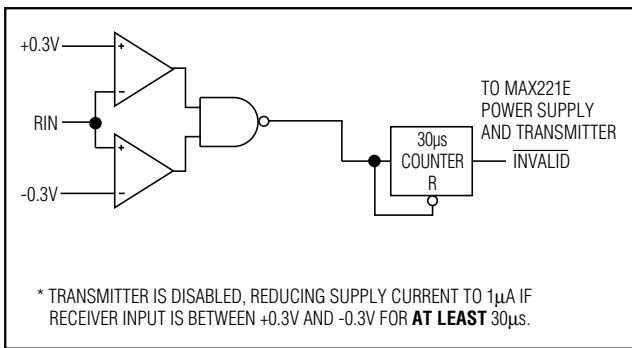

Figure 2a. Entering 1µA Supply Mode via AutoShutdown

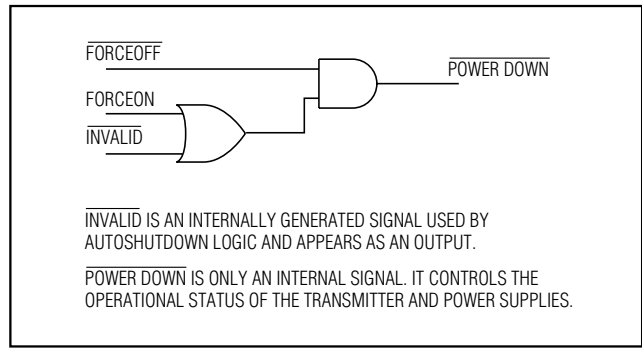

Figure 2c. AutoShutdown Logic

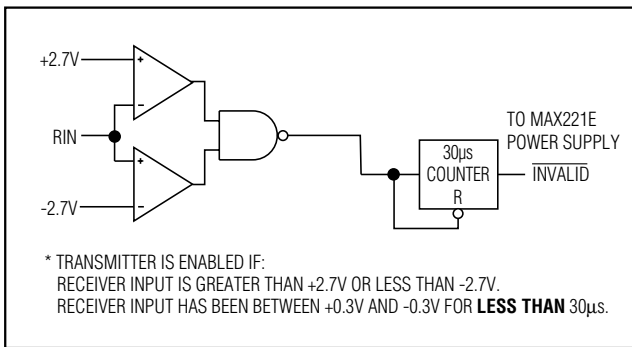

Figure 2b. Transmitter Enabled Using AutoShutdown

Table 2. INVALID Truth Table

RS-232 SIGNAL PRESENT AT RECEIVER INPUT	INVALID OUTPUT
Yes	High
No	Low

±15kV ESD-Protected, +5V, 1µA, Single RS-232 Transceiver with AutoShutdown

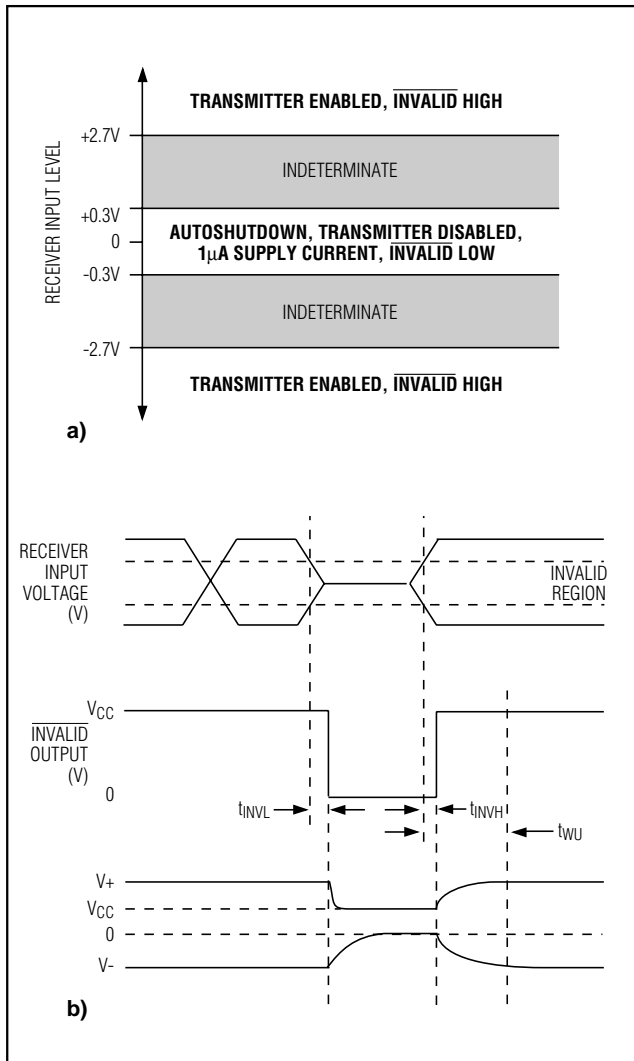

Figure 3. AutoShutdown Trip Levels

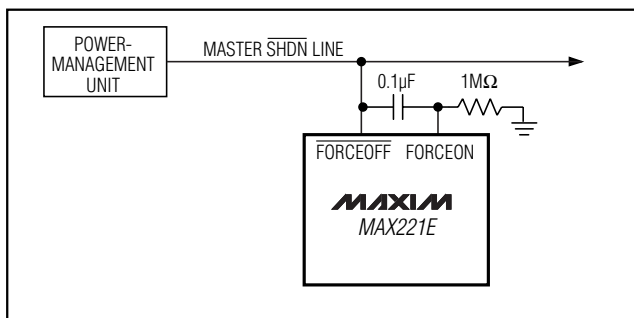

Figure 4. AutoShutdown with Initial Turn-On to Wake Up a Mouse or Another System

Software-Controlled Shutdown

For direct software control, use $\overline{\text{INVALID}}$ to indicate a DTR or Ring Indicator signal. Connect $\overline{\text{FORCEOFF}}$ and $\overline{\text{FORCEON}}$ together to disable AutoShutdown so the line acts like a SHDN input.

±15kV ESD Protection

As with all Maxim devices, ESD-protection structures are incorporated on all pins to protect against electrostatic discharges encountered during handling and assembly. The driver output and receiver input of the MAX221E have extra protection against static electricity. Maxim's engineers have developed state-of-the-art structures to protect these pins against ESD of ±15kV without damage. The ESD structures withstand high ESD in all states: normal operation, shutdown, and powered down. After an ESD event, Maxim's E versions keep working without latchup, whereas competing RS-232 products can latch and must be powered down to remove latchup.

ESD protection can be tested in various ways; the transmitter output and receiver input of the MAX221E are characterized for protection to the following limits:

- 1) ±15kV using the Human Body Model
- 2) ±8kV using the Contact-Discharge Method specified in IEC 1000-4-2
- 3) ±15kV using IEC 1000-4-2's Air-Gap Method

ESD Test Conditions

ESD performance depends on a variety of conditions. Contact Maxim for a reliability report that documents test setup, test methodology, and test results.

Human Body Model

Figure 5a shows the Human Body Model, and Figure 5b shows the current waveform it generates when discharged into a low impedance. This model consists of a 100pF capacitor charged to the ESD voltage of interest, which is then discharged into the test device through a 1.5kΩ resistor.

IEC 1000-4-2

The IEC 1000-4-2 standard covers ESD testing and performance of finished equipment; it does not specifically refer to integrated circuits. The MAX221E helps you design equipment that meets Level 4 (the highest level) of IEC 1000-4-2, without the need for additional ESD-protection components.

The major difference between tests done using the Human Body Model and IEC 1000-4-2 (Figure 6) is higher peak current in the IEC 1000-4-2 because series resistance is lower in the IEC 1000-4-2 model. Hence,

±15kV ESD-Protected, +5V, 1µA, Single RS-232 Transceiver with AutoShutdown

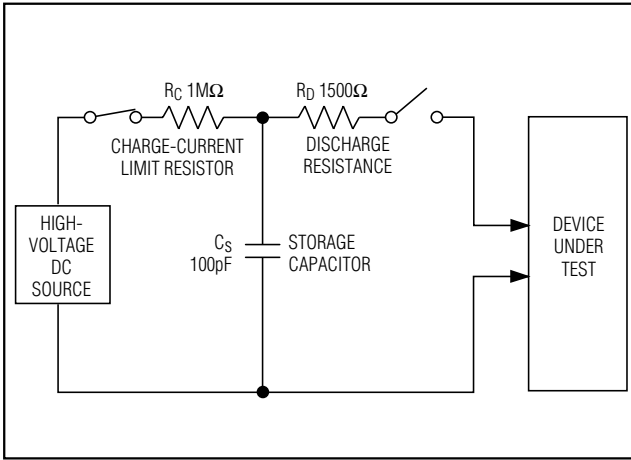

Figure 5a. Human Body ESD Test Model

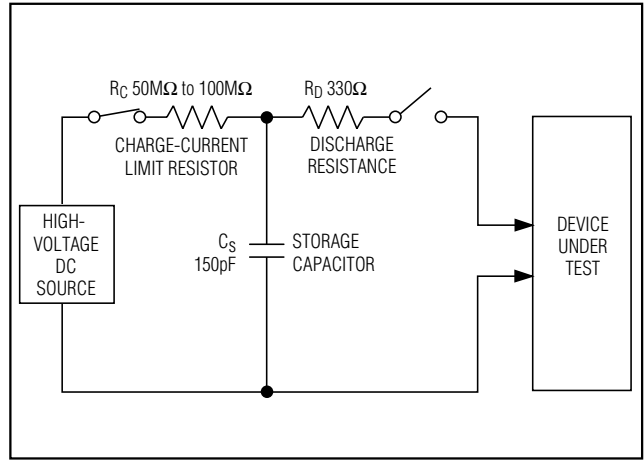

Figure 6a. IEC 1000-4-2 ESD Test Model

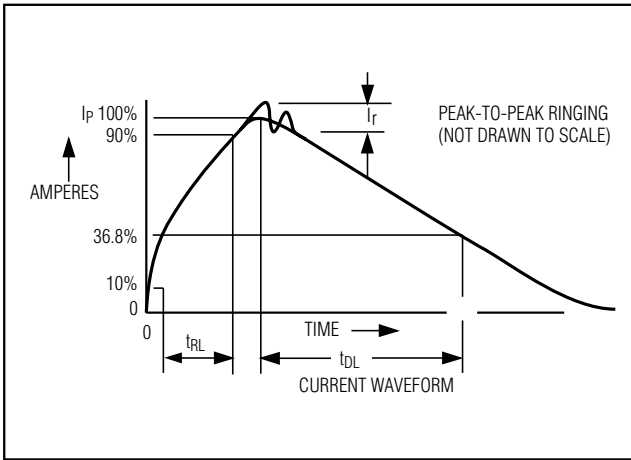

Figure 5b. Human Body Model Current Waveform

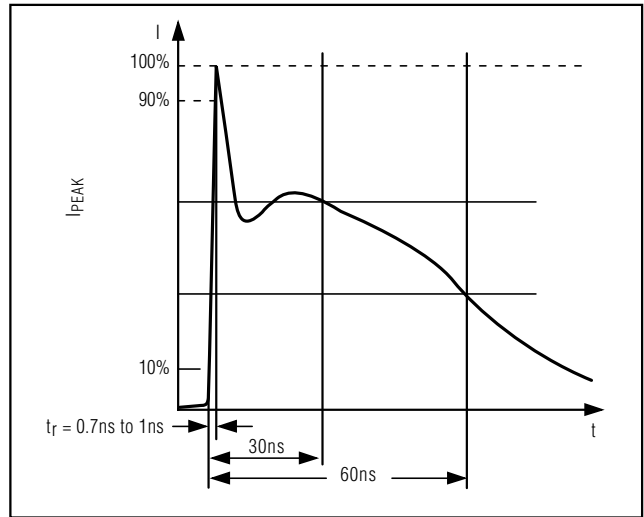

Figure 6b. IEC 1000-4-2 ESD Generator Current Waveform

the ESD that withstands voltage measured to IEC 1000-4-2 is generally lower than that measured using the Human Body Model. Figure 6a shows the IEEE 1000-4-2 model and Figure 6b shows the current waveform for the ±8kV IEC 1000-4-2 Level 4 ESD Contact-Discharge test.

The Air-Gap Method involves approaching the device with a charged probe. The Contact-Discharge Method connects the probe to the device before the probe is energized.

Machine Model

The Machine Model for ESD tests all pins, using a 200pF storage capacitor and zero discharge resistance. Its objective is to emulate the stress caused not only by RS-232 inputs and outputs, but also by contact that occurs due to handling and assembling during manufacturing. Therefore, after PC board assembly, the Machine Model is less relevant to I/O ports.

$\pm 15\text{kV}$ ESD-Protected, +5V, 1 μA , Single RS-232 Transceiver with AutoShutdown

Applications Information

Using INVALID

INVALID indicates when an RS-232 signal is present at the receiver input, and therefore when the port is in use. INVALID can be used in alternative shutdown control schemes where it relieves the processor from constantly polling the part for activity.

Capacitor Selection

The capacitor type used for C1–C4 is not critical for proper operation; either polarized or nonpolarized capacitors are acceptable. If polarized capacitors are used, connect polarity as shown in the *Typical Operating Circuit*. The charge pump requires 0.1 μF capacitors. Increasing the capacitor values (e.g., by a factor of 2) reduces ripple on the transmitter output, and slightly reduces power consumption. C2, C3, and C4 can be increased without changing C1's value. However, do not increase C1's value without also increasing the values of C2, C3, and C4 to maintain the proper ratios (C1 to the other capacitors).

When using the minimum 0.1 μF capacitors, make sure the capacitance does not degrade excessively with temperature. If in doubt, use capacitors with a larger

nominal value. The capacitor's equivalent series resistance (ESR) usually rises at low temperatures and influences the amount of ripple on V+ and V-.

Power-Supply Decoupling

In most circumstances, a 0.1 μF V_{CC} bypass capacitor is adequate. In applications that are sensitive to power-supply noise, use a capacitor of the same value as the charge-pump capacitor C1. Connect bypass capacitors as close to the IC as possible.

Transmitter Output when Exiting Shutdown

Figure 7 shows the transmitter output when exiting shutdown mode. The transmitter is loaded with 3k Ω in parallel with 1000pF. The transmitter output displays no ringing or undesirable transients as the MAX221E comes out of shutdown.

High Data Rates

The MAX221E maintains the RS-232 $\pm 5.0\text{V}$ minimum transmitter output voltage even at high data rates. Figure 8 shows a transmitter loopback test circuit. Figure 9 shows the loopback test result at 120kbps, and Figure 10 shows the same test at 250kbps.

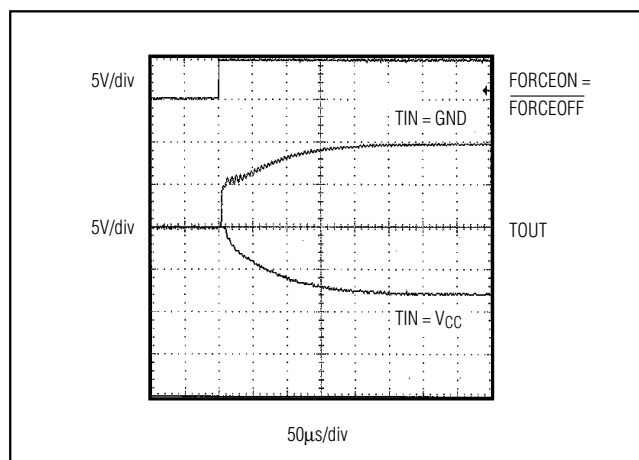

Figure 7. Transmitter Output when Exiting Shutdown or Powering Up

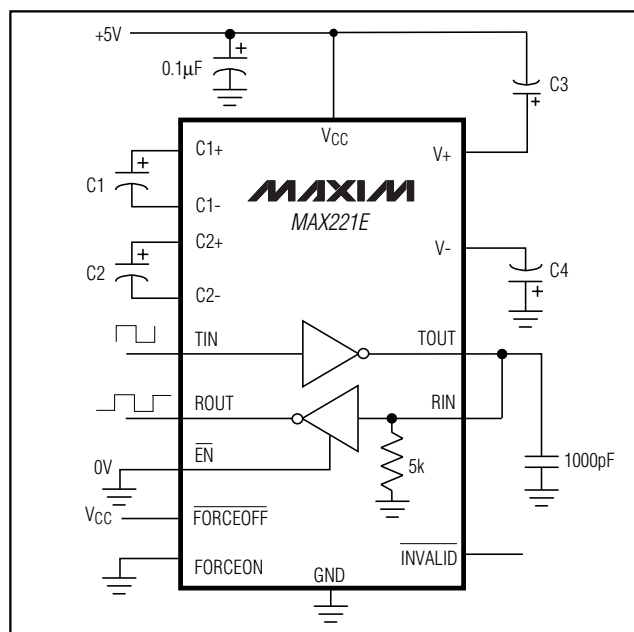

Figure 8. Loopback Test Circuit

$\pm 15\text{kV}$ ESD-Protected, +5V, 1 μA , Single RS-232 Transceiver with AutoShutdown

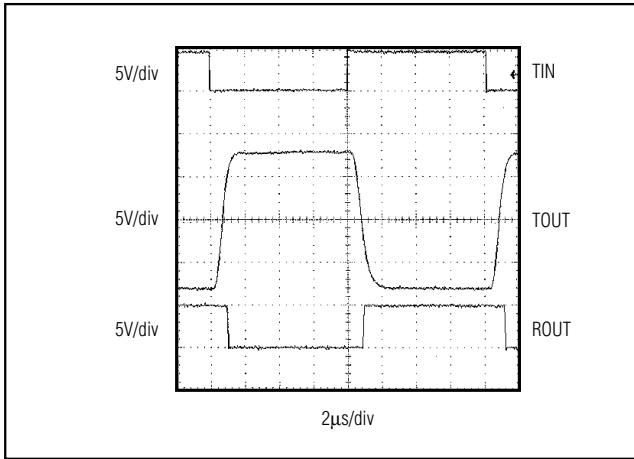

Figure 9. Loopback Test Result at 120kbps

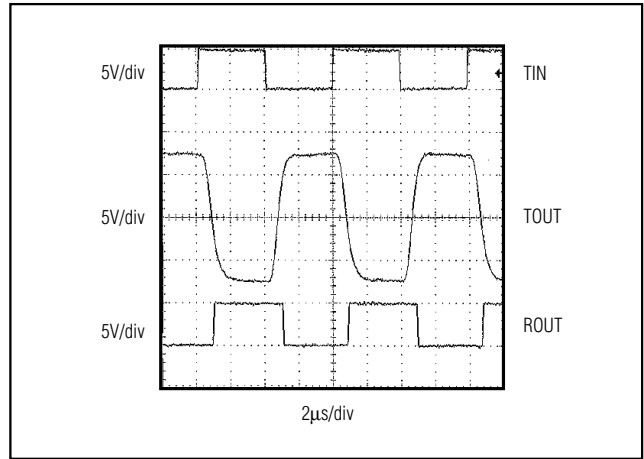

Figure 10. Loopback Test Result at 250kbps

Chip Information

TRANSISTOR COUNT: 157

±15kV ESD-Protected, +5V, 1µA, Single RS-232 Transceiver with AutoShutdown

Package Information

MAX221E

TSSOP-EPS

COMMON DIMENSIONS

	MILLIMETERS		INCHES	
	MIN.	MAX.	MIN.	MAX.
A	1.10		.043	
A ₁	0.05	0.15	.002	.006
A ₂	0.85	0.95	.033	.037
b	0.19	0.30	.007	.012
b ₁	0.19	0.25	.007	.010
c	0.090	0.20	.0035	.008
c ₁	0.090	0.135	.0035	.0053
D	SEE VARIATIONS		SEE VARIATIONS	
E	4.30	4.50	.169	.177
e	0.65 BSC		.026 BSC	
H	6.25	6.50	.246	.256
L	0.50	0.70	.020	.028
N	SEE VARIATIONS		SEE VARIATIONS	
Y	2.85	3.15	.112	.124
α	0°	8°	0°	8°

JEDEC	N	VARIATIONS				
		MILLIMETERS		INCHES		
MD-153		MIN.	MAX.	MIN.	MAX.	
AB	14	D	4.90	5.10	.193	.201
AC	16	D	4.90	5.10	.193	.201
AC-EP	16	D	4.90	5.10	.193	.201
AD	20	X	2.85	3.15	.112	.124
AD-EP	20	D	6.40	6.60	.252	.260
		D	6.40	6.60	.252	.260
AE	24	X	4.00	4.34	.157	.171
AF	28	D	7.70	7.90	.303	.311
AF-EP	28	D	9.60	9.80	.378	.386
		D	9.60	9.80	.378	.386
		X	5.35	5.65	.211	.222

NOTES:

- DIMENSIONS D AND E DO NOT INCLUDE FLASH.
- MOLD FLASH OR PROTRUSIONS NOT TO EXCEED .15 mm PER SIDE.
- CONTROLLING DIMENSION: MILLIMETER.
- MEETS JEDEC OUTLINE MD-153 VARIATIONS AB, AC, AD, AE, AF.
- DIMENSIONS X AND Y APPLY TO EXPOSED PAD (EP) VERSIONS ONLY.
- EXPOSED PAD FLUSH WITH BOTTOM OF PACKAGE WITHIN .002".

±15kV ESD-Protected, +5V, 1µA, Single RS-232 Transceiver with AutoShutdown

Package Information (continued)

DIM	INCHES		MILLIMETERS	
	MIN	MAX	MIN	MAX
A	0.068	0.078	1.73	1.99
A1	0.002	0.008	0.05	0.21
B	0.010	0.015	0.25	0.38
C	0.004	0.008	0.09	0.20
D	SEE VARIATIONS			
E	0.205	0.209	5.20	5.38
e	0.0256	BSC	0.65	BSC
H	0.301	0.311	7.65	7.90
L	0.025	0.037	0.63	0.95
α	0°	8°	0°	8°

D	INCHES		MILLIMETERS		
	MIN	MAX	MIN	MAX	
D	0.239	0.249	6.07	6.33	14L
D	0.239	0.249	6.07	6.33	16L
D	0.278	0.289	7.07	7.33	20L
D	0.317	0.328	8.07	8.33	24L
D	0.397	0.407	10.07	10.33	28L

NOTES:
 1. D&E DO NOT INCLUDE MOLD FLASH.
 2. MOLD FLASH OR PROTRUSIONS NOT TO EXCEED .15mm (.006")
 3. CONTROLLING DIMENSION: MILLIMETER

MAXIM			
<small>PROPRIETARY INFORMATION</small>			
<small>TITLE:</small>			
PACKAGE OUTLINE, SSOP, 5.3X.65mm			
<small>APPROVAL</small>	<small>DOCUMENT CONTROL NO.</small>	<small>REV</small>	<small>1/1</small>
	21-0056	A	

SSOP EFS

Maxim cannot assume responsibility for use of any circuitry other than circuitry entirely embodied in a Maxim product. No circuit patent licenses are implied. Maxim reserves the right to change the circuitry and specifications without notice at any time.