

19-1632; Rev 1; 6/01



+3.0V to +5.5V, 10nA, 250kbps RS-232 Transceivers with ±15kV ESD-Protected I/O and Logic Pins

General Description

The MAX3238E/MAX3248E transceivers use Maxim's revolutionary AutoShutdown Plus™ feature to achieve 10nA supply current. These devices shut down the on-board power supply and drivers when they do not sense a valid signal transition on either the receiver or transmitter inputs. This occurs if the RS-232 cable is disconnected or if the transmitters of the connected peripheral are turned off. The devices turn on again when a valid transition is applied to any RS-232 receiver or transmitter input. AutoShutdown Plus automatically achieves this power savings through its on-board circuitry, as no changes are required to the existing BIOS or operating system.

All RS-232 inputs and outputs, as well as the logic I/O pins, have enhanced ESD protection to ±15kV. The additional ESD protection on the logic I/O pins makes the MAX3238E/MAX3248E ideal for cell phone data cable applications because it eliminates the need for costly external TransZorb™ or protection schemes.

The MAX3238E/MAX3248E contain five drivers and three receivers and are 3V-powered EIA/TIA-232 and V.28/V.24 communication interfaces intended for cell phones, data cables, and modem applications. A proprietary, high-efficiency, dual charge-pump power supply and a low-dropout transmitter combine to deliver true RS-232 performance from a single +3.0V to +5.5V supply. A guaranteed data rate of 250kbps provides compatibility with popular software for communicating with personal computers.

The MAX3238E and the MAX3248E differ only in their input logic thresholds. The MAX3238E has standard logic thresholds, while the MAX3248E has low-level logic thresholds of 0.6V to 1.2V, which are ideal for 1.8V systems.

The transmitter inputs, FORCEON, and FORCEOFF have a 400kΩ active positive feedback resistor. Once driven to a valid logic level, they will retain this level if the driving signal is removed or goes high impedance. Unused transmitter and logic inputs may be left unconnected. The MAX3238E/MAX3248E can operate with supply voltages ranging from +3.0V to +5.5V.

Applications

Cellular Data Cables	Peripherals
Modems	Data Cradles
Battery-Powered Equipment	Printers

AutoShutdown Plus is a trademark of Maxim Integrated Products.

TransZorb is a trademark of General Semiconductor Industries, Inc.

† Covered by U.S. Patent numbers 4,636,930; 4,679,134; 4,777,577; 4,797,899; 4,809,152; 4,897,774; 4,999,761; and other patents pending.

Features

- ◆ Enhanced ESD Protection on RS-232 I/O Pins and All Logic Pins
 - ±15kV—Human Body Model
 - ±8kV—IEC 1000-4-2 Contact Discharge
 - ±15kV—IEC 1000-4-2 Air-Gap Discharge
- ◆ Guaranteed Data Rate: 250kbps
- ◆ 10nA Low-Power Shutdown with Receivers Active
- ◆ Schmitt Triggers on All Inputs
- ◆ Flow-Through Pinout
- ◆ Meets EIA/TIA-232 Specifications Down to 3.0V
- ◆ Guaranteed 6V/μs Slew Rate
- ◆ Low-Level Logic Thresholds (MAX3248E)
- ◆ RS-232-Compatible Outputs to 2.7V

Ordering Information

PART	TEMP. RANGE	PIN-PACKAGE
MAX3238ECAI	0°C to +70°C	28 SSOP
MAX3238EEAI	-40°C to +85°C	28 SSOP
MAX3248ECAI	0°C to +70°C	28 SSOP
MAX3248EEAI	-40°C to +85°C	28 SSOP

Typical Operating Circuit appears at end of data sheet.

Pin Configuration

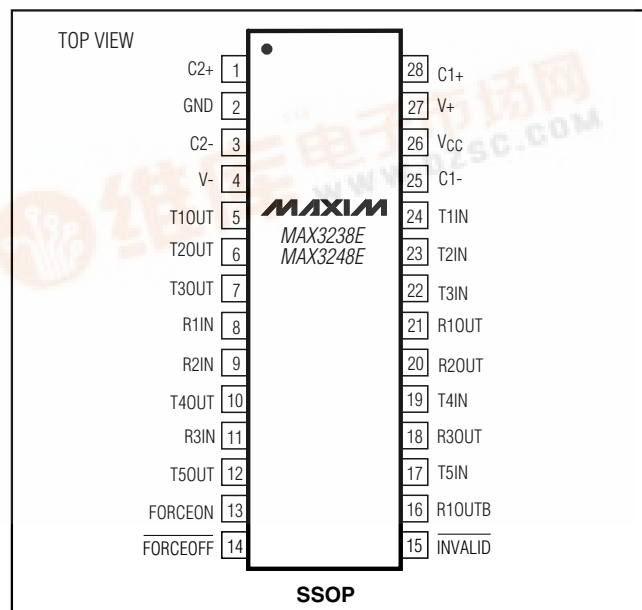

MAX3238E/MAX3248E



+3.0V to +5.5V, 10nA, 250kbps RS-232 Transceivers with ±15kV ESD-Protected I/O and Logic Pins

ABSOLUTE MAXIMUM RATINGS

V _{CC}	-0.3V to +6V	Short-Circuit Duration	
V+ (Note 1).....	-0.3V to +7V	T_OUT (one at a time).....	Continuous
V- (Note 1).....	+0.3V to -7V	Continuous Power Dissipation (T _A = +70°C)	
V+ + IV-I (Note 1).....	+13V	28-Pin SSOP (derate 9.52mW/°C above +70°C).....	762mW
Input Voltages		Operating Temperature Ranges	
T_IN, FORCEOFF, FORCEON.....	-0.3V to +6V	MAX3238ECAI/MAX3248ECAI.....	0°C to +70°C
R_IN.....	±25V	MAX3238EEAI/MAX3248EEAI.....	-40°C to +85°C
Output Voltages		Storage Temperature Range.....	-65°C to +150°C
T_OUT.....	±13.2V	Lead Temperature (soldering, 10s).....	+300°C
R_OUT, INVALID.....	-0.3V to (V _{CC} + 0.3V)		

Note 1: V+ and V- can have a maximum magnitude of +7V, but their absolute difference can not exceed +13V.

Stresses beyond those listed under "Absolute Maximum Ratings" may cause permanent damage to the device. These are stress ratings only, and functional operation of the device at these or any other conditions beyond those indicated in the operational sections of the specifications is not implied. Exposure to absolute maximum rating conditions for extended periods may affect device reliability.

ELECTRICAL CHARACTERISTICS

(V_{CC} = +3.0V to +5.5V, C1–C4 = 0.1μF (tested at 3.3V ±5%), C1–C4 = 0.22μF (tested at 3.3V ±10%), C1 = 0.047μF, and C2–C4 = 0.33μF (tested at 5.0V ±10%), T_A = T_{MIN} to T_{MAX}, unless otherwise noted. Typical values are at T_A = +25°C.)

PARAMETER	CONDITIONS	MIN	TYP	MAX	UNITS
DC CHARACTERISTICS (V _{CC} = +3.3V or +5.0V, T _A = +25°C)					
Supply Current, AutoShutdown Plus	Receivers idle, T_IN = V _{CC} or GND, FORCEON = GND, FORCEOFF = V _{CC}		0.75	6	μA
	R_IN = FORCEON = GND, FORCEOFF = V _{CC} , T_IN = V _{CC} or GND		10	300	nA
Supply Current, Shutdown	FORCEOFF = GND, R_IN = GND, T_IN = V _{CC} or GND		10	300	nA
Supply Current, AutoShutdown Plus Disabled	FORCEON = FORCEOFF = V _{CC} , no load		0.5	2.0	mA
LOGIC INPUTS AND RECEIVER OUTPUTS					
Input Logic Threshold Low	MAX3238E	T_IN (active)	0.8	1.20	V
		FORCEON, FORCEOFF, and T_IN wake-up threshold; V _{CC} = 3.3V	0.8	1.00	
		FORCEON, FORCEOFF, and T_IN wake-up threshold; V _{CC} = 5.0V	0.8	1.45	
	MAX3248E	T_IN (active)	0.6	0.7	
		FORCEON, FORCEOFF, and T_IN wake-up threshold; V _{CC} = 3.3V	0.6	0.85	
		FORCEON, FORCEOFF, and T_IN wake-up threshold; V _{CC} = 5.0V	0.6	1.0	
Input Logic Threshold High	MAX3238E	T_IN (active)	1.60	2.0	V
		FORCEON, FORCEOFF, and T_IN wake-up threshold; V _{CC} = 3.3V	1.30	2.0	
		FORCEON, FORCEOFF, and T_IN wake-up threshold; V _{CC} = 5.0V	2.10	2.4	
	MAX3248E	T_IN (active)	1.10	1.2	
		FORCEON, FORCEOFF, and T_IN wake-up threshold; V _{CC} = 3.3V	0.95	1.2	
		FORCEON, FORCEOFF, and T_IN wake-up threshold; V _{CC} = 5.0V	1.15	1.6	

+3.0V to +5.5V, 10nA, 250kbps RS-232 Transceivers with ±15kV ESD-Protected I/O and Logic Pins

ELECTRICAL CHARACTERISTICS (continued)

(V_{CC} = +3.0V to +5.5V, C1–C4 = 0.1 μ F (tested at 3.3V \pm 5%), C1–C4 = 0.22 μ F (tested at 3.3V \pm 10%), C1 = 0.047 μ F, and C2–C4 = 0.33 μ F (tested at 5.0V \pm 10%), T_A = T_{MIN} to T_{MAX} , unless otherwise noted. Typical values are at T_A = +25°C.)

PARAMETER	CONDITIONS	MIN	TYP	MAX	UNITS
Input Leakage Current	T_{IN} , FORCEON, $\overline{FORCEOFF}$ (Note 2)		9	18	μ A
Output Leakage Current	Receivers disabled		\pm 0.05	\pm 10	μ A
Output Voltage Low	I_{OUT} = 1.0mA			0.4	V
Output Voltage High	I_{OUT} = -1.0mA	V_{CC} - 0.6	V_{CC} - 0.1		V
RECEIVER INPUTS					
Input Voltage Range		-25		25	V
Input Threshold Low	V_{CC} = 3.3V	0.6	1.0		V
	V_{CC} = 5.0V	0.8	1.4		
Input Threshold High	V_{CC} = 3.3V		1.5	2.4	V
	V_{CC} = 5.0V		2.0	2.4	
Input Hysteresis			0.6		V
Input Resistance	T_A = +25°C	3	5	7	k Ω
AutoShutdown (FORCEON = GND, $\overline{FORCEOFF}$ = V_{CC})					
Receiver Input Threshold to $\overline{INVALID}$ Output High	Figure 4a	Positive threshold		2.7	V
		Negative threshold	-2.7		
Receiver Input Threshold to $\overline{INVALID}$ Output Low	Figure 4a	-0.3		0.3	V
$\overline{INVALID}$ Output Voltage Low	I_{OUT} = 1.0mA			0.4	V
$\overline{INVALID}$ Output Voltage High	I_{OUT} = -1.0mA	V_{CC} - 0.6			V
Receiver Positive or Negative Threshold to $\overline{INVALID}$ High (t_{INVH})	V_{CC} = 5V, Figure 4b		0.3		μ s
Receiver Positive or Negative Threshold to $\overline{INVALID}$ Low (t_{INVL})	V_{CC} = 5V, Figure 4b		60		μ s
Receiver or Transmitter Edge to Transmitters Enabled (t_{WU})	V_{CC} = 5V, Figure 4b (Note 3)		25		μ s
Receiver or Transmitter Edge to Shutdown ($t_{AUTOSHDN}$)	Figure 4b	15	30	60	s
TRANSMITTER OUTPUTS					
Output Voltage Swing	All transmitter outputs loaded with 3k Ω to ground	\pm 5.0	\pm 5.4		V
Output Resistance	V_{CC} = 0, T_{OUT} = \pm 2V	300	50k		Ω
Output Short-Circuit Current	V_{CC} \leq 3.6V		\pm 35	\pm 60	mA
	V_{CC} > 3.6V		\pm 40	\pm 100	
ESD PROTECTION					
ESD Protection (R_{IN} , T_{IN} , R_{OUT} , T_{OUT} , FORCEON, $\overline{FORCEOFF}$, $\overline{INVALID}$, R_{OUTB})	IEC 1000-4-2 Air-Gap Discharge Method		\pm 15		kV
	IEC 1000-4-2 Contact Discharge Method		\pm 8		
	Human Body Model		\pm 15		

+3.0V to +5.5V, 10nA, 250kbps RS-232 Transceivers with ±15kV ESD-Protected I/O and Logic Pins

ELECTRICAL CHARACTERISTICS (continued)

($V_{CC} = +3.0V$ to $+5.5V$, $C_1-C_4 = 0.1\mu F$ (tested at $3.3V \pm 5\%$), $C_1-C_4 = 0.22\mu F$ (tested at $3.3V \pm 10\%$), $C_1 = 0.047\mu F$, and $C_2-C_4 = 0.33\mu F$ (tested at $5.0V \pm 10\%$), $T_A = T_{MIN}$ to T_{MAX} , unless otherwise noted. Typical values are at $T_A = +25^\circ C$.)

PARAMETER	CONDITIONS	MIN	TYP	MAX	UNITS
TIMING CHARACTERISTICS					
Maximum Data Rate	$R_L = 3k\Omega$, $C_L = 1000pF$, one transmitter switching	250			kbps
Receiver Propagation Delay	R_{IN} to R_{OUT} , $C_L = 150pF$	t_{PHL}	0.15		μs
		t_{PLH}	0.15		
Receiver Output Enable Time	Normal operation		2.6		μs
Receiver Output Disable Time	Normal operation		2.4		μs
Transmitter Skew	$ t_{PHL} - t_{PLH} $		50		ns
Receiver Skew	$ t_{PHL} - t_{PLH} $		50		ns
Transition-Region Slew Rate	$V_{CC} = 3.3V$, $T_A = +25^\circ C$, $R_L = 3k\Omega$ to $7k\Omega$, measured from $+3V$ to $-3V$ or $-3V$ to $+3V$	$C_L = 150pF$ to $1000pF$	6	30	$V/\mu s$
		$C_L = 150pF$ to $2500pF$	4	30	

Note 2: The transmitter inputs have an active positive feedback resistor. The input current goes to zero when the inputs are at the supply rails.

Note 3: During AutoShutdown only, a transmitter/receiver edge is defined as a transition through the transmitter/receiver input logic wake-up thresholds.

Typical Operating Characteristics

($V_{CC} = +3.3V$, 250kbps data rate, $0.1\mu F$ capacitors, all transmitters loaded with $3k\Omega$, $T_A = +25^\circ C$, unless otherwise noted.)

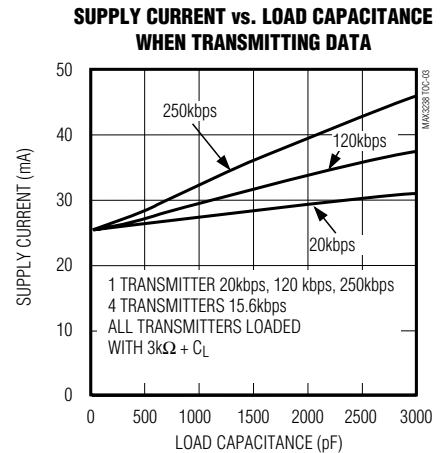
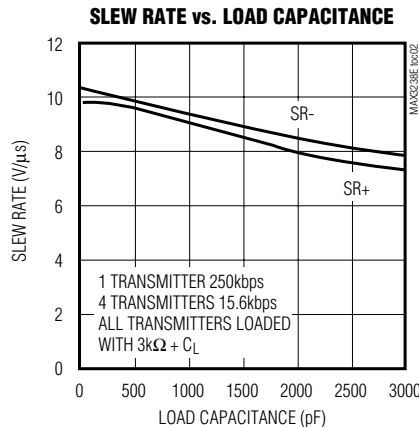
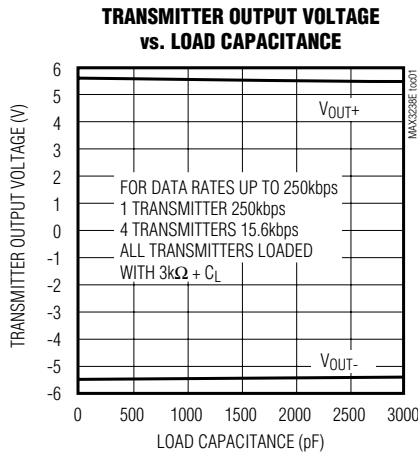

+3.0V to +5.5V, 10nA, 250kbps RS-232 Transceivers with ±15kV ESD-Protected I/O and Logic Pins

Typical Operating Characteristics (continued)

(V_{CC} = +3.3V, 250kbps data rate, 0.1μF capacitors, all transmitters loaded with 3kΩ, T_A = +25°C, unless otherwise noted.)

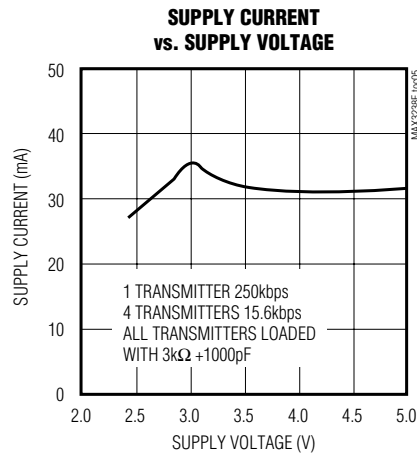
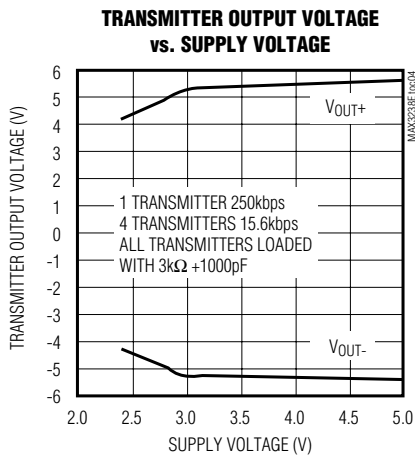

Pin Description

PIN	NAME	FUNCTION
1	C2+	Positive Terminal of Inverting Charge-Pump Capacitor
2	GND	Ground
3	C2-	Negative Terminal of Inverting Charge-Pump Capacitor
4	V-	-5.5V Generated by the Charge Pump
5, 6, 7, 10, 12	T_OUT	RS-232 Transmitter Outputs (T1OUT–T5OUT)
8, 9, 11	R_IN	RS-232 Receiver Inputs (R1IN–R3IN)
13	FORCEON	Force-On Input. Drive high to override AutoShutdown Plus, keeping transmitters and receivers on (FORCEOFF must be high) (Table 1). This pin has an active positive feedback resistor. Once driven to a valid logic level, the pin retains that level if left unconnected until power is cycled.
14	FORCEOFF	Force-Off Input. Drive low to shut down transmitters, receivers (except R1OUTB), and on-board supply. This overrides AutoShutdown Plus and FORCEON (Table 1). This pin has an active positive feedback resistor. Once driven to a valid logic level, the pin retains that level if left unconnected until power is cycled.
15	INVALID	Output of the Valid Signal Detector. A logic 1 indicates if a valid RS-232 level is present on receiver inputs.
16	R1OUTB	Noninverting Complementary Receiver Output. Always active.
17, 19, 22, 23, 24	T_IN	TTL/CMOS Transmitter Inputs (T5IN–T1IN). This pin has an active positive feedback resistor. Once driven to a valid logic level, the pin retains that level if left unconnected until power is cycled.
18, 20, 21	R_OUT	TTL/CMOS Receiver Outputs (R3OUT–R1OUT)
25	C1-	Negative Terminal of Voltage-Doubler Charge-Pump Capacitor
26	V _{CC}	+3.0V to +5.5V Supply Voltage
27	V+	+5.5V Generated by the Charge Pump
28	C1+	Positive Terminal of Voltage-Doubler Charge-Pump Capacitor

+3.0V to +5.5V, 10nA, 250kbps RS-232 Transceivers with $\pm 15\text{kV}$ ESD-Protected I/O and Logic Pins

Table 1. Output Control Truth Table

FORCEON	$\overline{\text{FORCEOFF}}$	AutoShutdown Plus	OPERATION STATUS	T_OUT	R_OUT	R1OUTB
X	0	X	Shutdown (Forced Off)	High-Z	High-Z	Active
1	1	X	Normal Operation (Forced On)	Active	Active	Active
0	1	<30s*	Normal Operation (AutoShutdown Plus)	Active	Active	Active
0	1	>30s*	Shutdown (AutoShutdown Plus)	High-Z	Active	Active

X = Don't care

*Time since last receiver or transmitter input transition.

Detailed Description

Dual Charge-Pump Voltage Converter

The MAX3238E/MAX3248Es' internal power supply consists of a regulated dual charge pump that provides output voltages of +5.5V (doubling charge pump) and -5.5V (inverting charge pump), regardless of the input voltage (V_{CC}) over the 3.0V to 5.5V range. The charge pumps operate in a discontinuous mode: if the output voltages are less than 5.5V, the charge pumps are enabled; if the output voltages exceed 5.5V, the charge pumps are disabled. Each charge pump requires a flying capacitor (C1, C2) and a reservoir capacitor (C3, C4) to generate the V_+ and V_- supplies.

RS-232 Transmitters

The MAX3248E transmitters are inverting level translators that convert a logic low of 0.6V and logic high of 1.2V to 5.0V EIA/TIA-232 levels. The MAX3238E transmitters are inverting level translators that convert CMOS-logic levels to 5.0V EIA/TIA-232 levels. The MAX3238E/MAX3248E transmitters both guarantee a 250kbps data rate with worst-case loads of $3\text{k}\Omega$ in parallel with 1000pF, providing compatibility with PC-to-PC communication software (such as LapLink™). Transmitters can be paralleled to drive multiple receivers. Figure 1 shows a complete system connection.

When $\overline{\text{FORCEOFF}}$ is driven to ground, the transmitters and receivers are disabled and the outputs go high impedance, except for R1OUTB. When the Auto-Shutdown Plus circuitry senses that all receiver and transmitter inputs are inactive for more than 30s, the transmitters are disabled and the outputs go into a high-impedance state, but the receivers remain active. When the power is off, the MAX3238E/MAX3248E permit the outputs to be driven up to $\pm 12\text{V}$.

The transmitter inputs, FORCEON and $\overline{\text{FORCEOFF}}$, have a $400\text{k}\Omega$ active positive-feedback resistor. Once driven to a valid logic level, they will retain this level if the driving signal is removed or goes high-impedance. Unused transmitter inputs may be left unconnected.

RS-232 Receivers

The receivers convert RS-232 signals to CMOS-logic output levels. All receivers have inverting three-state outputs and are inactive in shutdown ($\overline{\text{FORCEOFF}}$) (Table 1). The MAX3238E/MAX3248E also feature an extra, always-active noninverting output, R1OUTB. This extra output monitors receiver activity while the other receivers are high impedance, allowing Ring Indicator to be monitored without forward biasing other devices connected to the receiver outputs. This is ideal for systems where V_{CC} is set to 0 in shutdown to accommodate peripherals, such as UARTs (Figure 2).

+3.0V to +5.5V, 10nA, 250kbps RS-232 Transceivers with ±15kV ESD-Protected I/O and Logic Pins

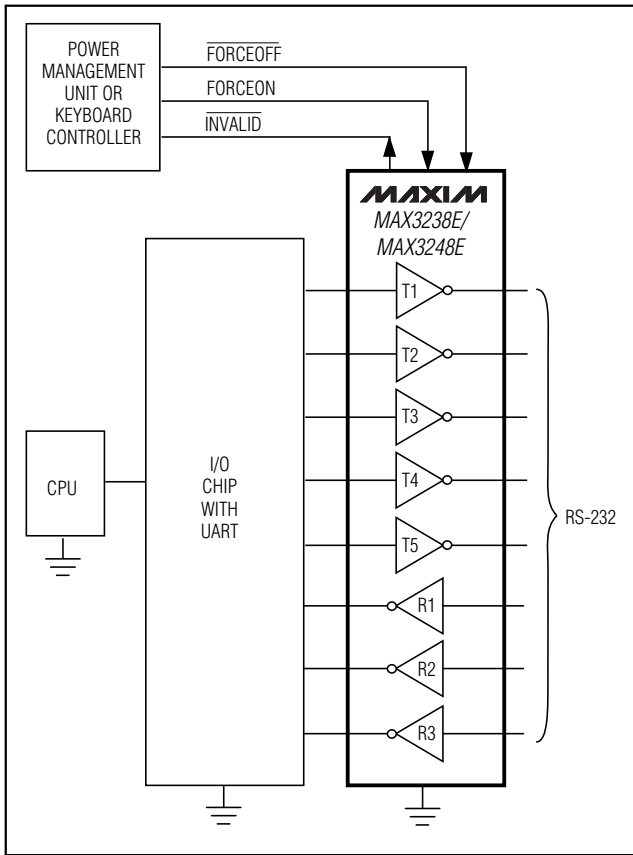

Figure 1. Interface Under Control of PMU

AutoShutdown Plus Mode

A 10nA supply current is achieved with Maxim's AutoShutdown Plus feature, which operates when $\overline{\text{FORCEOFF}}$ is low and FORCEON is high. When the MAX3238E/MAX3248E sense no valid signal transitions on all receiver and transmitter inputs for 30s, the on-board power supply and drivers are shut off, reducing supply current to $1\mu\text{A}$. If the receiver inputs are in the invalid range ($-0.3\text{V} < R_{\text{IN}} < +0.3\text{V}$) and the transmitter inputs are at GND or V_{CC} , supply current is further reduced to 10nA. This occurs if the RS-232 cable is disconnected or if the connected peripheral transmitters are turned off. The system turns on again when a valid transition is applied to any RS-232 receiver or transmitter input. As a result, the system saves power without changes to the existing BIOS or operating system. The $\overline{\text{INVALID}}$ output is high when the receivers are active. Since $\overline{\text{INVALID}}$ indicates the receiver inputs' condition, it can be used in any mode (Figure 3).

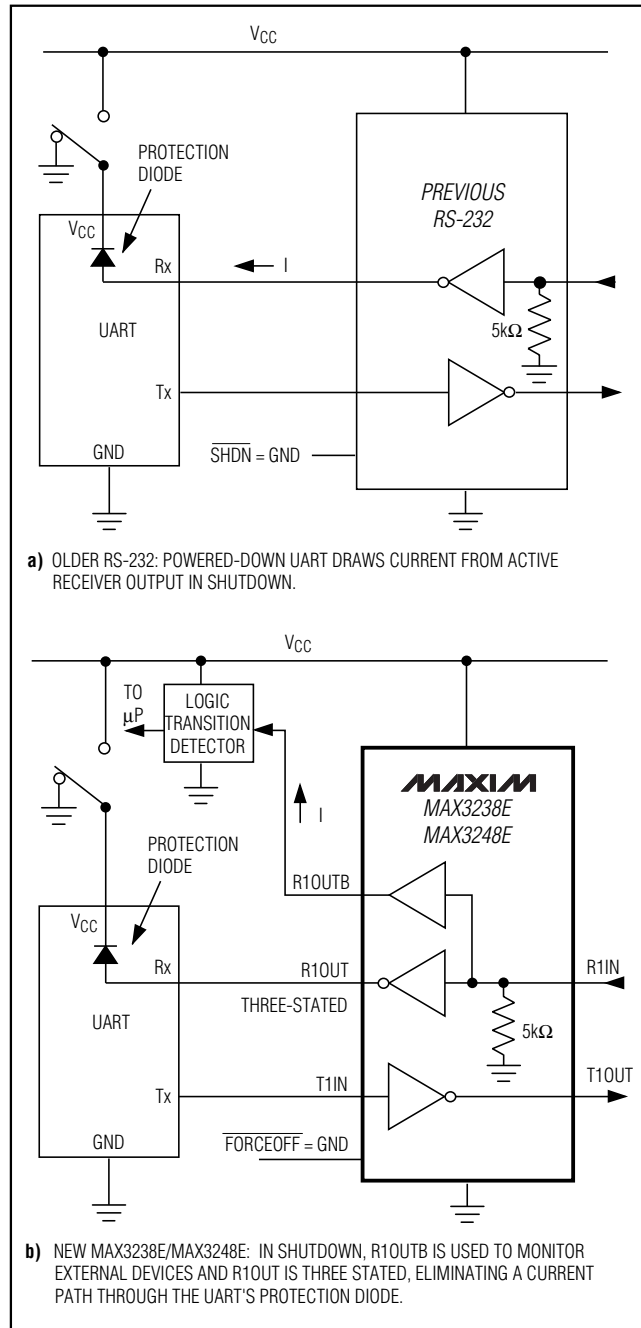

Figure 2. MAX3238E/MAX3248E detect RS-232 activity when the UART and interface are shut down.

+3.0V to +5.5V, 10nA, 250kbps RS-232 Transceivers with ±15kV ESD-Protected I/O and Logic Pins

Table 2. $\overline{\text{INVALID}}$ Truth Table

RS-232 SIGNAL PRESENT AT ANY RECEIVER INPUT	$\overline{\text{INVALID}}$ OUTPUT
Yes	H
No	L

Tables 1 and 2 and Figure 3 summarize the MAX3238E/MAX2348Es' operating modes. FORCEON and $\overline{\text{FORCEOFF}}$ override the automatic circuitry and force the transceiver into its normal operating state or into its low-power standby state. When neither control is asserted, the IC enters AutoShutdown Plus mode and selects between these states automatically, based on the last receiver or transmitter input edge received.

When shut down, the devices' charge pumps turn off, V+ decays to VCC, V- decays to ground, and the transmitter outputs are disabled (high impedance). The time required to recover from shutdown is typically 25µs (Figure 4b).

Software-Controlled Shutdown

If direct software control is desired, use $\overline{\text{INVALID}}$ to indicate DTR or Ring Indicator signal. Tie $\overline{\text{FORCEOFF}}$ and FORCEON together to bypass the AutoShutdown Plus feature so the line acts like a SHDN input.

ESD Protection

As with all Maxim devices, ESD protection structures are incorporated to protect against electrostatic discharges (ESDs) encountered during handling and assembly. The MAX3238E/MAX3248E RS-232 transmitters and receivers, as well as the I/O have extra protection against static electricity found in normal operation. Maxim's engineers developed state-of-the-art structures to protect these pins against ESD of ±15kV without damage. After an ESD event, the MAX3238E/MAX3248E keep working without latchup.

ESD protection can be tested in various ways. The pins are characterized for protection to ±15kV and ±8kV (see *Electrical Characteristics*).

ESD Test Conditions

Contact Maxim for a reliability report that documents test setup, methodology, and results.

Human Body Model

Figure 5a shows the Human Body Model, and Figure 5b shows the current waveform it generates when discharged into a low impedance. This model consists of a 100pF capacitor charged to the ESD voltage of inter-

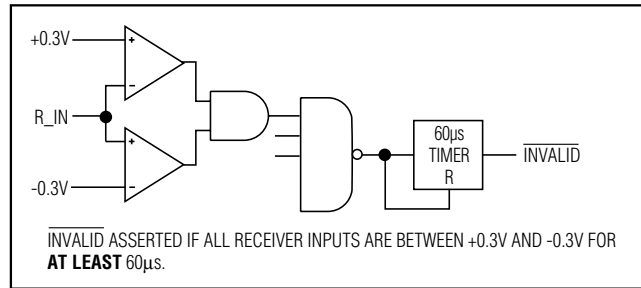

Figure 3a. $\overline{\text{INVALID}}$ Functional Diagram, $\overline{\text{INVALID}}$ Low

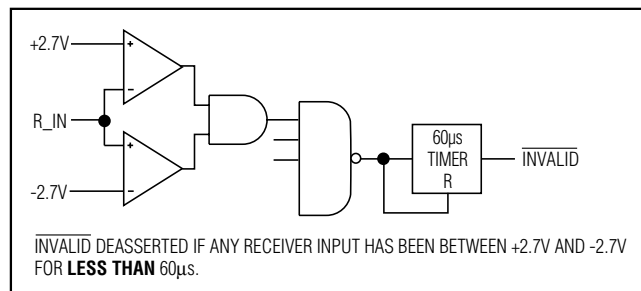

Figure 3b. $\overline{\text{INVALID}}$ Functional Diagram, $\overline{\text{INVALID}}$ High

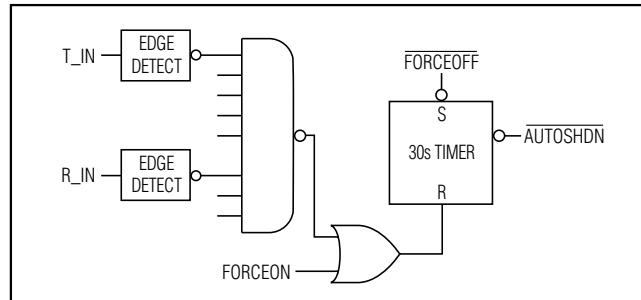

Figure 3c. AutoShutdown Plus Logic

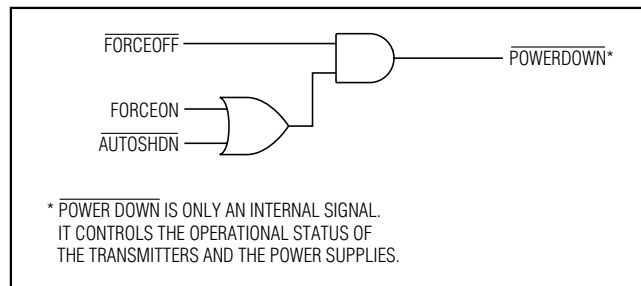

Figure 3d. Power-Down Logic

+3.0V to +5.5V, 10nA, 250kbps RS-232 Transceivers with ±15kV ESD-Protected I/O and Logic Pins

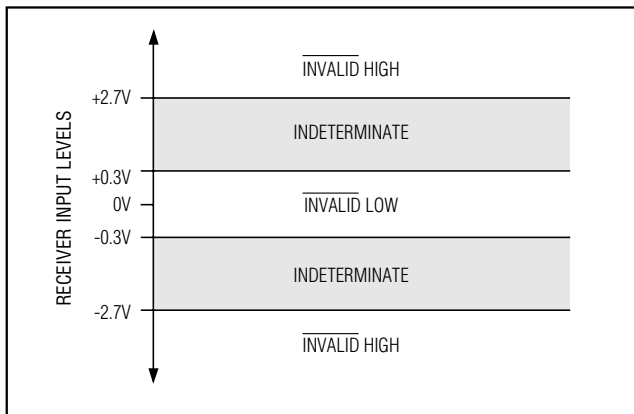

Figure 4a. Receiver Positive/Negative Thresholds for $\overline{\text{INVALID}}$

est, which is then discharged into the test device through a 1.5kΩ resistor.

IEC 1000-4-2

The IEC 1000-4-2 standard covers ESD testing and performance of finished equipment; it does not specifically refer to integrated circuits. The MAX3238E/MAX3248E

help you design equipment that meets Level 4 (the highest level) of IEC 1000-4-2, without additional ESD protection components.

The major difference between tests done using the Human Body Model and IEC 1000-4-2 is higher peak current in IEC 1000-4-2. Because series resistance is lower in the IEC 1000-4-2 ESD test model (Figure 6a), the ESD withstand voltage measured to this standard is generally lower than that measured using the Human Body Model. Figure 6b shows the current waveform for the ±8kV IEC 1000-4-2 Level 4 ESD Contact Discharge test.

The Air-Gap test involves approaching the device with a charged probe. The Contact Discharge method connects the probe to the device before the probe is energized.

Machine Model

The Machine Model for ESD testing uses a 200pF storage capacitor and zero-discharge resistance. Its objective is to mimic the stress caused by contact that occurs with handling and assembly during manufacturing. Of course, all pins (not just RS-232 inputs and outputs) require this protection during manufacturing.

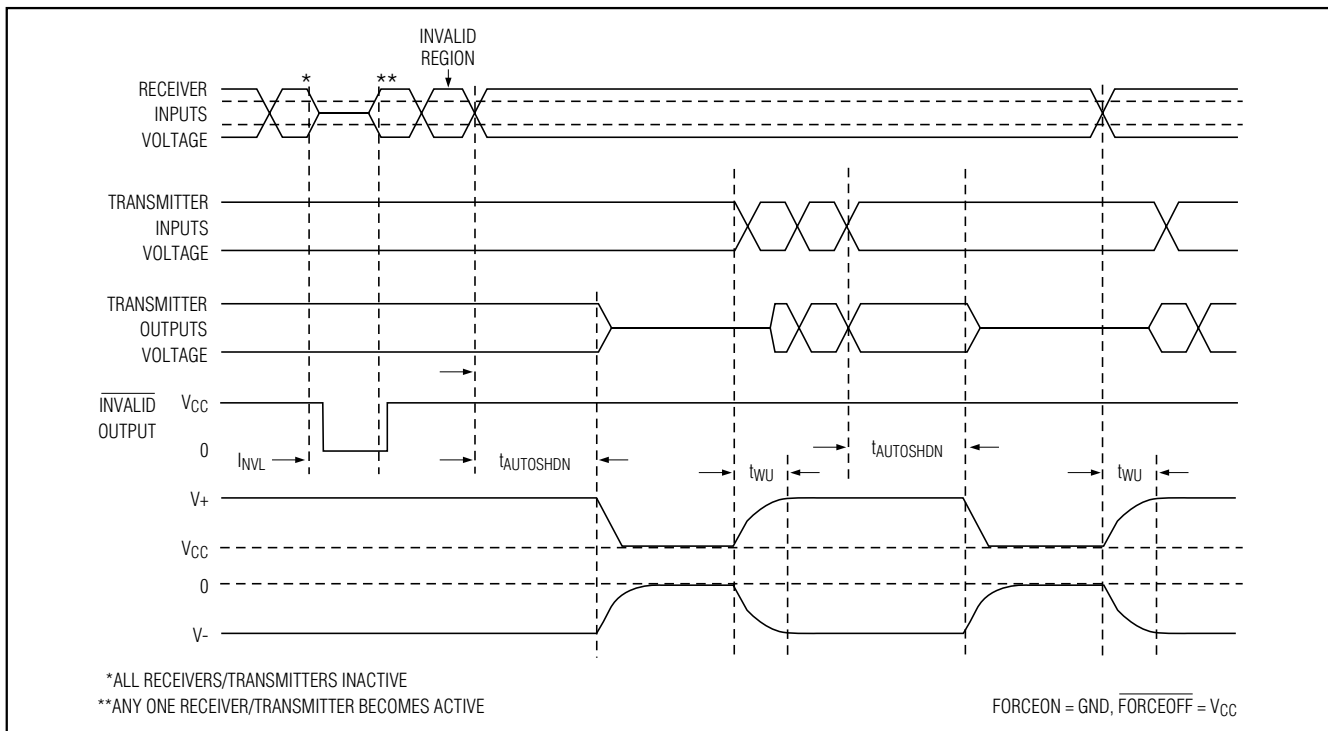

Figure 4b. AutoShutdown Plus and $\overline{\text{INVALID}}$ Timing Diagram

+3.0V to +5.5V, 10nA, 250kbps RS-232 Transceivers with ±15kV ESD-Protected I/O and Logic Pins

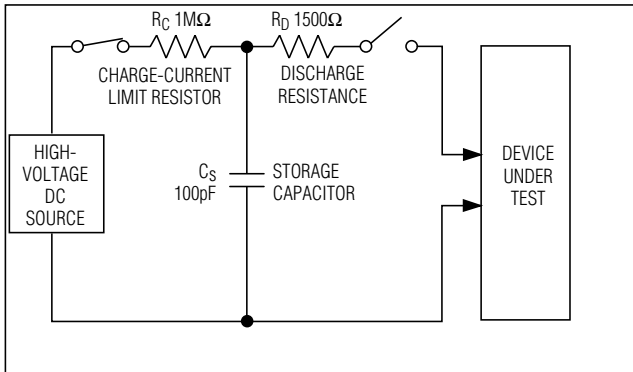

Figure 5a. Human Body ESD Test Model

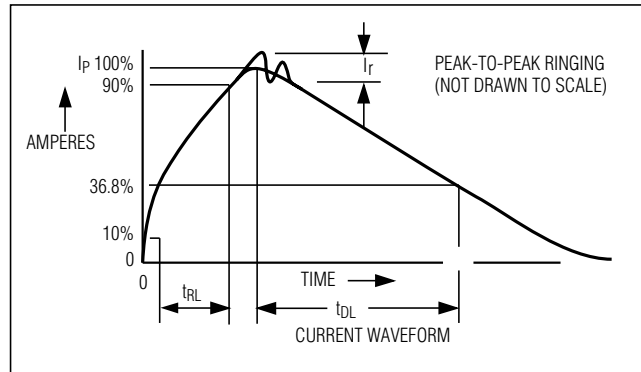

Figure 5b. Human Body Model Current Waveform

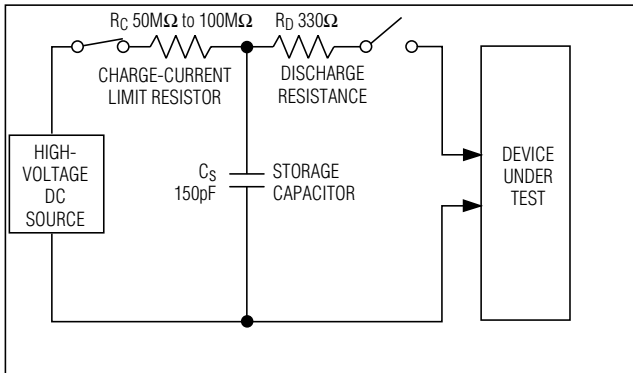

Figure 6a. IEC 1000-4-2 ESD Test Model

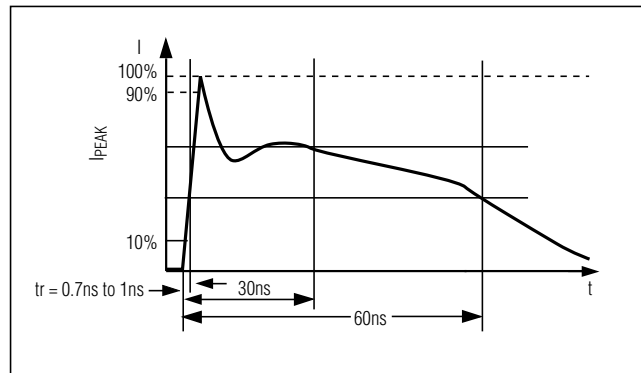

Figure 6b. IEC 1000-4-2 ESD Generator Current Waveform

Therefore, the Machine Model is less relevant to the I/O ports than the Human Body Model and IEC 1000-4-2.

Applications Information

Capacitor Selection

The capacitor type used for C1–C4 is not critical for proper operation; polarized or nonpolarized capacitors can be used. The charge pump requires 0.1μF capacitors for 3.3V operation. For other supply voltages, see Table 3 for required capacitor values. Do not use values smaller than those listed in Table 3. Increasing the capacitor values (e.g., by a factor of 2) reduces ripple on the transmitter outputs and slightly reduces power consumption. C2, C3, and C4 can be increased without changing C1's value. However, **do not increase C1 without also increasing the values of C2, C3, C4, and CBYPASS** to maintain the proper ratios (C1 to the other capacitors).

Power-Supply Decoupling

In most applications, decouple VCC to ground with a 0.1μF capacitor. Further increasing this capacitor value reduces power-supply ripple and enhances noise margin. Connect the bypass capacitor as close to the IC as possible.

Table 3. Required Minimum Capacitance Values

VCC (V)	C1, CBYPASS (μF)	C2, C3, C4 (μF)
3.0 to 3.6	0.22	0.22
3.15 to 3.6	0.1	0.1
4.5 to 5.5	0.047	0.33
3.0 to 5.5	0.22	1

+3.0V to +5.5V, 10nA, 250kbps RS-232 Transceivers with ±15kV ESD-Protected I/O and Logic Pins

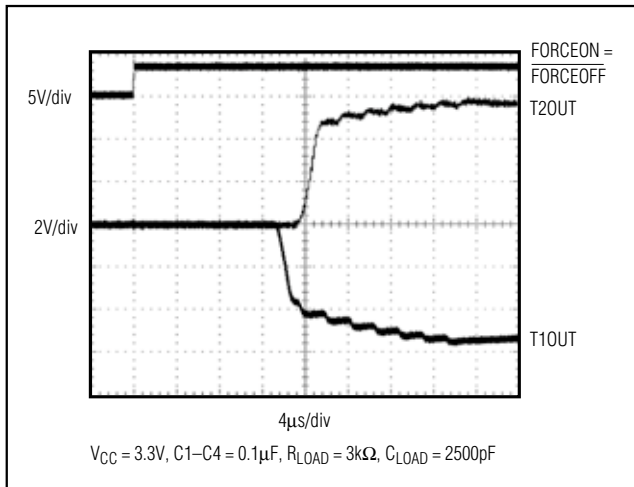

Figure 7. Transmitter Outputs when Recovering from Shutdown or Powering Up

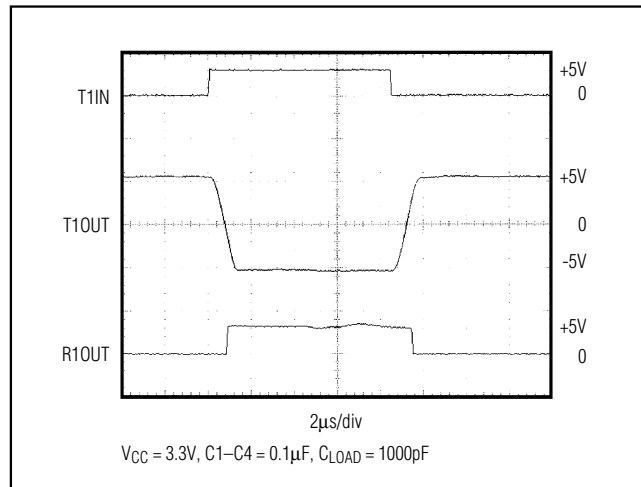

Figure 9. Loopback Test Result at 120kbps

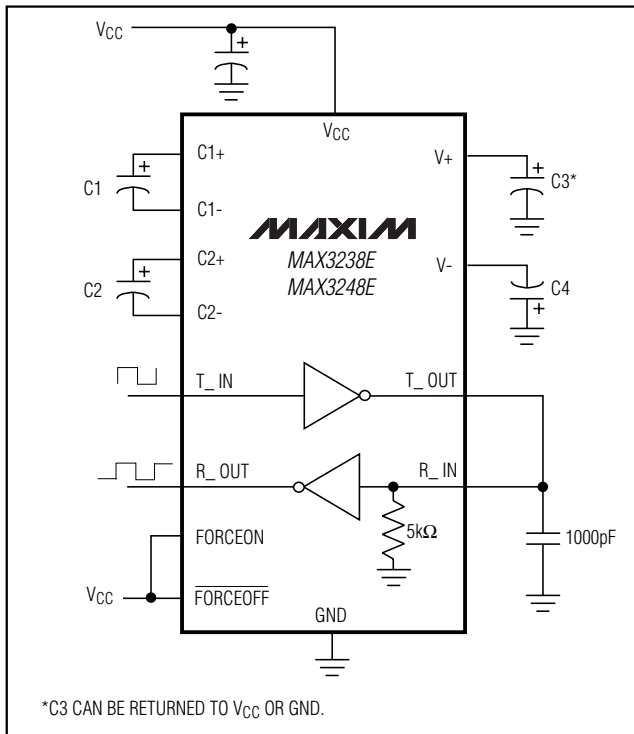

Figure 8. Loopback Test Circuit

Transmitter Outputs when Recovering from Shutdown

Figure 7 shows two transmitter outputs when recovering from shutdown mode. As they become active, the out-

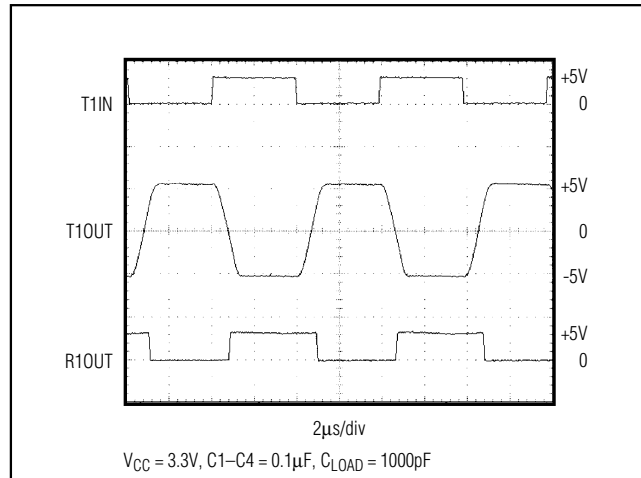

Figure 10. Loopback Test Result at 250kbps

puts are shown going to opposite RS-232 levels (one transmitter input is high, the other is low). Each transmitter is loaded with 3kΩ in parallel with 2500pF. The transmitter outputs display no ringing or undesirable transients as they come out of shutdown. Note that the transmitters are enabled only when the magnitude of V- exceeds approximately 3V.

High Data Rates

The MAX3238E/MAX3248E maintain the RS-232 ±5.0V minimum transmitter output voltage even at high data rates. Figure 8 shows a transmitter loopback test circuit. Figure 9 shows a loopback test result at 120kbps,

+3.0V to +5.5V, 10nA, 250kbps RS-232 Transceivers with ±15kV ESD-Protected I/O and Logic Pins

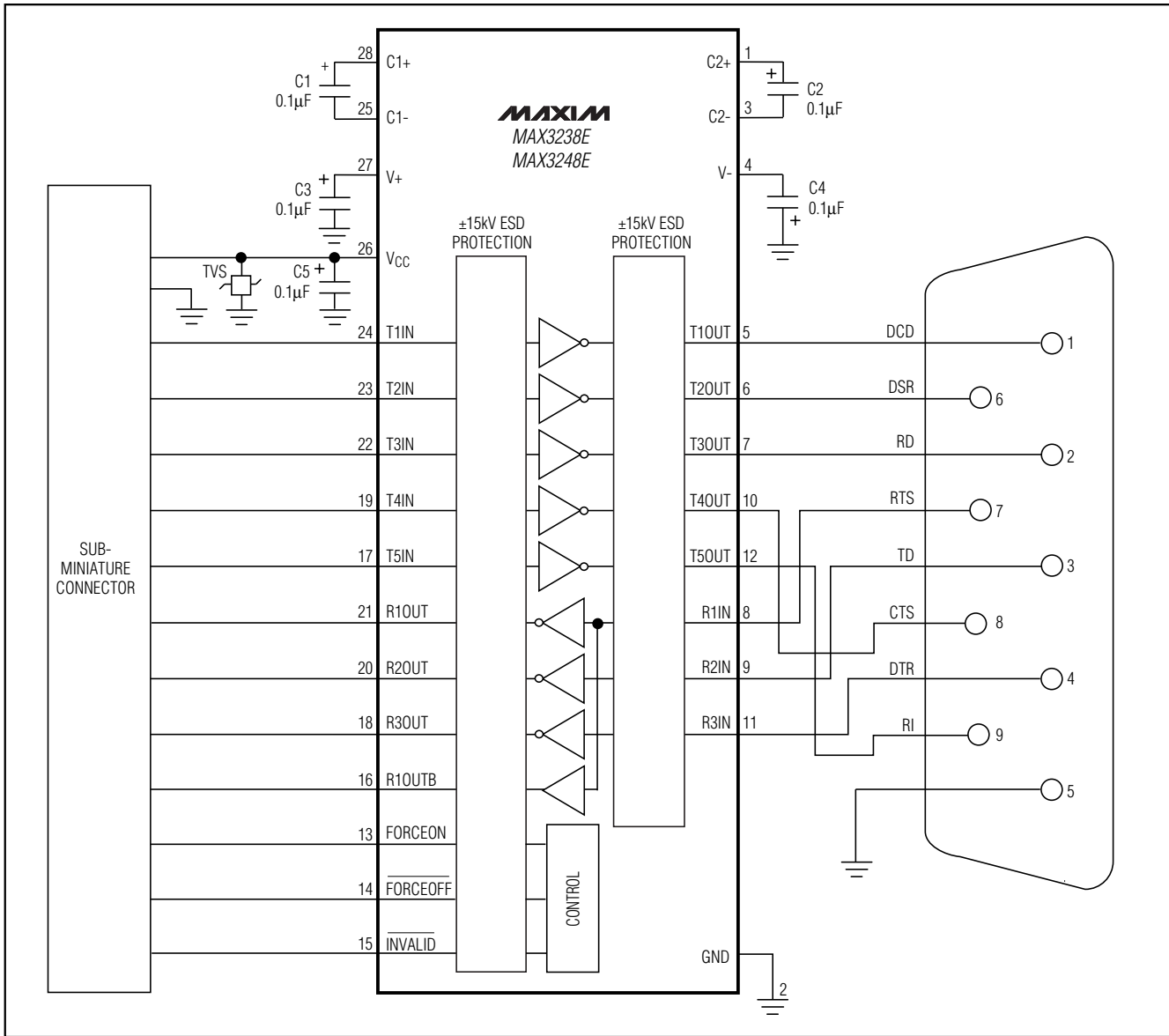
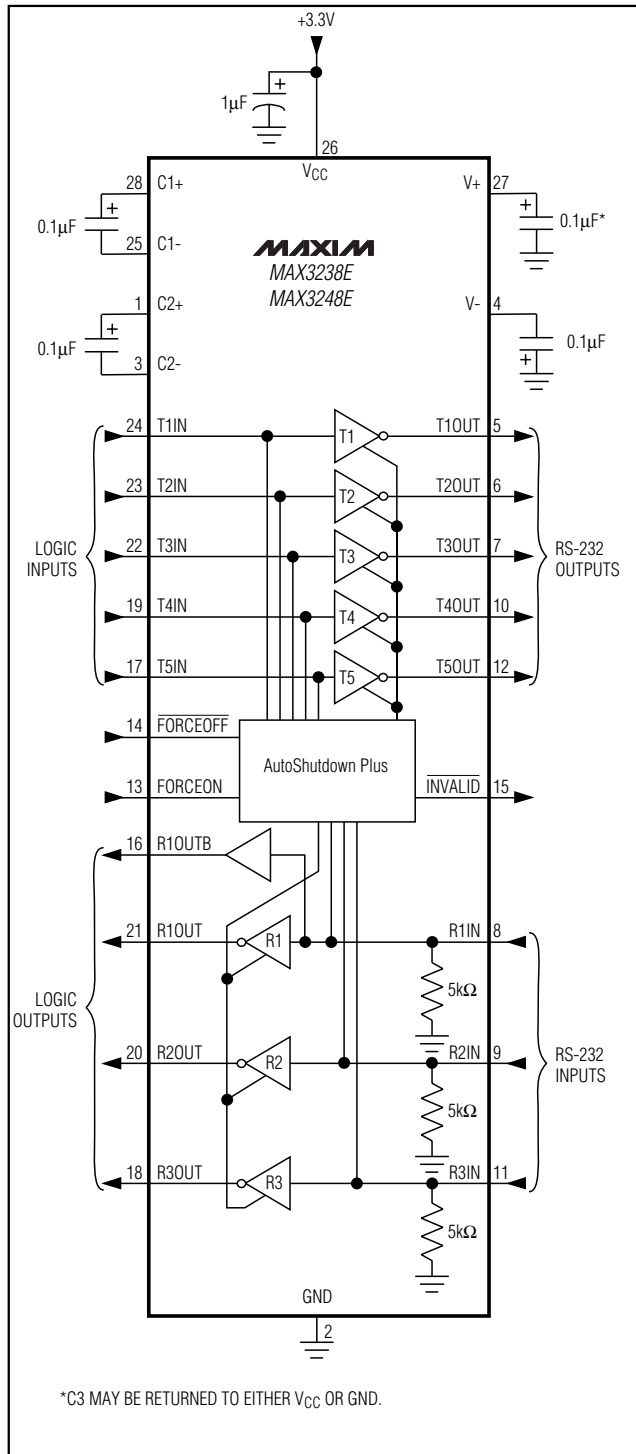

Figure 11. Data Cable Application Example

+3.0V to +5.5V, 10nA, 250kbps RS-232 Transceivers with ±15kV ESD-Protected I/O and Logic Pins

Typical Operating Circuit



and Figure 10 shows the same test at 250kbps. For Figure 9, all transmitters were driven simultaneously at 120kbps into RS-232 loads in parallel with 1000pF. For Figure 10, a single transmitter was driven at 250kbps, and all transmitters were loaded with an RS-232 receiver in parallel with 1000pF.

Data Cable Applications

The MAX3238E/MAX3248Es' ±15kV ESD protection on both the RS-232 I/Os as well as the logic I/Os makes them ideal candidates for data cable applications. A data cable is both an electrical connection and a level translator, allowing ultra-miniaturization of cell phones and other small portable devices.

Previous data cable approaches suffered from complexity due to the required protection circuits on both the logic side of the cable as well as on the RS-232 connections. The example shown in Figure 10 shows the ease of using the MAX3238E/MAX3248E in data cable applications.

The MAX3238E/MAX3248Es' five-transmitter and three-receiver configuration is optimized for a data communication equipment (DCE) application, allowing full hardware handshaking. The 9-pin RS-232 connector is configured for direct attachment to a PC's serial port.

R1OUTB is also connected to the subminiature connector. This allows the remote system to shut down until the PC asserts the ready to send (RTS) signal. R1OUTB stays active when the MAX3238E/MAX3248E is shut down (FORCEOFF = GND).

Chip Information

TRANSISTOR COUNT: 2110

+3.0V to +5.5V, 10nA, 250kbps RS-232 Transceivers with ±15kV ESD-Protected I/O and Logic Pins

Package Information

DIM	INCHES		MILLIMETERS	
	MIN	MAX	MIN	MAX
A	0.068	0.078	1.73	1.99
A1	0.002	0.008	0.05	0.21
B	0.010	0.015	0.25	0.38
C	0.004	0.008	0.09	0.20
D	SEE VARIATIONS			
E	0.205	0.209	5.20	5.38
e	0.0256	BSC	0.65	BSC
H	0.301	0.311	7.65	7.90
L	0.025	0.037	0.63	0.95
α	0°	8°	0°	8°

D	INCHES		MILLIMETERS		N
	MIN	MAX	MIN	MAX	
D	0.239	0.249	6.07	6.33	14L
D	0.239	0.249	6.07	6.33	16L
D	0.278	0.289	7.07	7.33	20L
D	0.317	0.328	8.07	8.33	24L
D	0.397	0.407	10.07	10.33	28L

NOTES:

1. D&E DO NOT INCLUDE MOLD FLASH.
2. MOLD FLASH OR PROTRUSIONS NOT TO EXCEED .15mm (.006").
3. CONTROLLING DIMENSION: MILLIMETERS.
4. MEETS JEDEC MO150.

PROPRIETARY INFORMATION

TITLE:
PACKAGE OUTLINE, SSOP, 5.3x.65mm

APPROVAL	DOCUMENT CONTROL NO. 21-0056	REV B	1/1
----------	---------------------------------	----------	-----

SSOP/EPS