



PRELIMINARY DATA SHEET

# 256M bits SDRAM WTR (Wide Temperature Range)

**EDS2504APTA-TI (64M words × 4 bits)**  
**EDS2508APTA-TI (32M words × 8 bits)**  
**EDS2516APTA-TI (16M words × 16 bits)**

**Description**

The EDS2504AP is a 256M bits SDRAM organized as 16,777,216 words × 4 bits × 4 banks. The EDS2508 AP is a 256M bits SDRAM organized as 8,388,608 words × 8 bits × 4 banks. The EDS2516 AP is a 256M bits SDRAM organized as 4194304 words × 16 bits × 4 banks. All inputs and outputs are referred to the rising edge of the clock input. It is packaged in standard 54-pin plastic TSOP (II).

**Features**

- 3.3V power supply
- Clock frequency: 133MHz (max.)
- LVTTTL interface
- Single pulsed /RAS
- 4 banks can operate simultaneously and independently
- Burst read/write operation and burst read/single write operation capability
- Programmable burst length (BL): 1, 2, 4, 8, full page
- 2 variations of burst sequence
  - Sequential (BL = 1, 2, 4, 8)
  - Interleave (BL = 1, 2, 4, 8)
- Programmable /CAS latency (CL): 2, 3
- Byte control by DQM
  - : DQM (EDS2504/08AP)
  - : UDQM, LDQM (EDS2516AP)
- Refresh cycles: 8192 refresh cycles/64ms
- 2 variations of refresh
  - Auto refresh
  - Self refresh
- Ambient temperature range: -40 to +85°C

**Pin Configurations**

/xxx indicates active low signal.

			54-pin TSOP					
VDD	VDD	VDD	1	54	VSS	VSS	VSS	
NC	DQ0	DQ0	2	53	DQ15	DQ7	NC	
VDDQ	VDDQ	VDDQ	3	52	VSSQ	VSSQ	VSSQ	
NC	NC	DQ1	4	51	DQ14	NC	NC	
DQ0	DQ1	DQ2	5	50	DQ13	DQ6	DQ3	
VSSQ	VSSQ	VSSQ	6	49	VDDQ	VDDQ	VDDQ	
NC	NC	DQ3	7	48	DQ12	NC	NC	
NC	DQ2	DQ4	8	47	DQ11	DQ5	NC	
VDDQ	VDDQ	VDDQ	9	46	VSSQ	VSSQ	VSSQ	
NC	NC	DQ5	10	45	DQ10	NC	NC	
DQ1	DQ3	DQ6	11	44	DQ9	DQ4	DQ2	
VSSQ	VSSQ	VSSQ	12	43	VDDQ	VDDQ	VDDQ	
NC	NC	DQ7	13	42	DQ8	NC	NC	
VDD	VDD	VDD	14	41	VSS	VSS	VSS	
NC	NC	LDQM	15	40	NC	NC	NC	
/WE	/WE	/WE	16	39	UDQM	DQM	DQM	
/CAS	/CAS	/CAS	17	38	CLK	CLK	CLK	
/RAS	/RAS	/RAS	18	37	CKE	CKE	CKE	
/CS	/CS	/CS	19	36	A12	A12	A12	
BA0	BA0	BA0	20	35	A11	A11	A11	
BA1	BA1	BA1	21	34	A9	A9	A9	
A10	A10	A10	22	33	A8	A8	A8	
A0	A0	A0	23	32	A7	A7	A7	
A1	A1	A1	24	31	A6	A6	A6	
A2	A2	A2	25	30	A5	A5	A5	
A3	A3	A3	26	29	A4	A4	A4	
VDD	VDD	VDD	27	28	VSS	VSS	VSS	

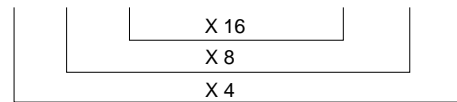

(Top view)

A0 to A12,	Address input	DQM	Input/output mask
BA0, BA1	Bank select address	CKE	Clock enable
DQ0 to DQ15	Data-input/output	CLK	Clock input
/CS	Chip select	VDD	Power for internal circuit
/RAS	Row address strobe	VSS	Ground for internal circuit
/CAS	Column address strobe	VDDQ	Power for DQ circuit
/WE	Write enable	VSSQ	Ground for DQ circuit
		NC	No connection

**Ordering Information**

Part number	Mask Version	Organization (words × bits)	Internal Banks	Clock frequency MHz (max.)	/CAS latency	Package
EDS2504APTA-7ATI	P	64M × 4	4	133	2, 3	54-pin Plastic TSOP (II)
EDS2504APTA-75TI					3	
EDS2508APTA-7ATI		32M × 8			2, 3	
EDS2508APTA-75TI					3	
EDS2516APTA-7ATI		16M × 16			2, 3	
EDS2516APTA-75TI					3	

**Part Number**

**EDS2504APTA - 7ATI**

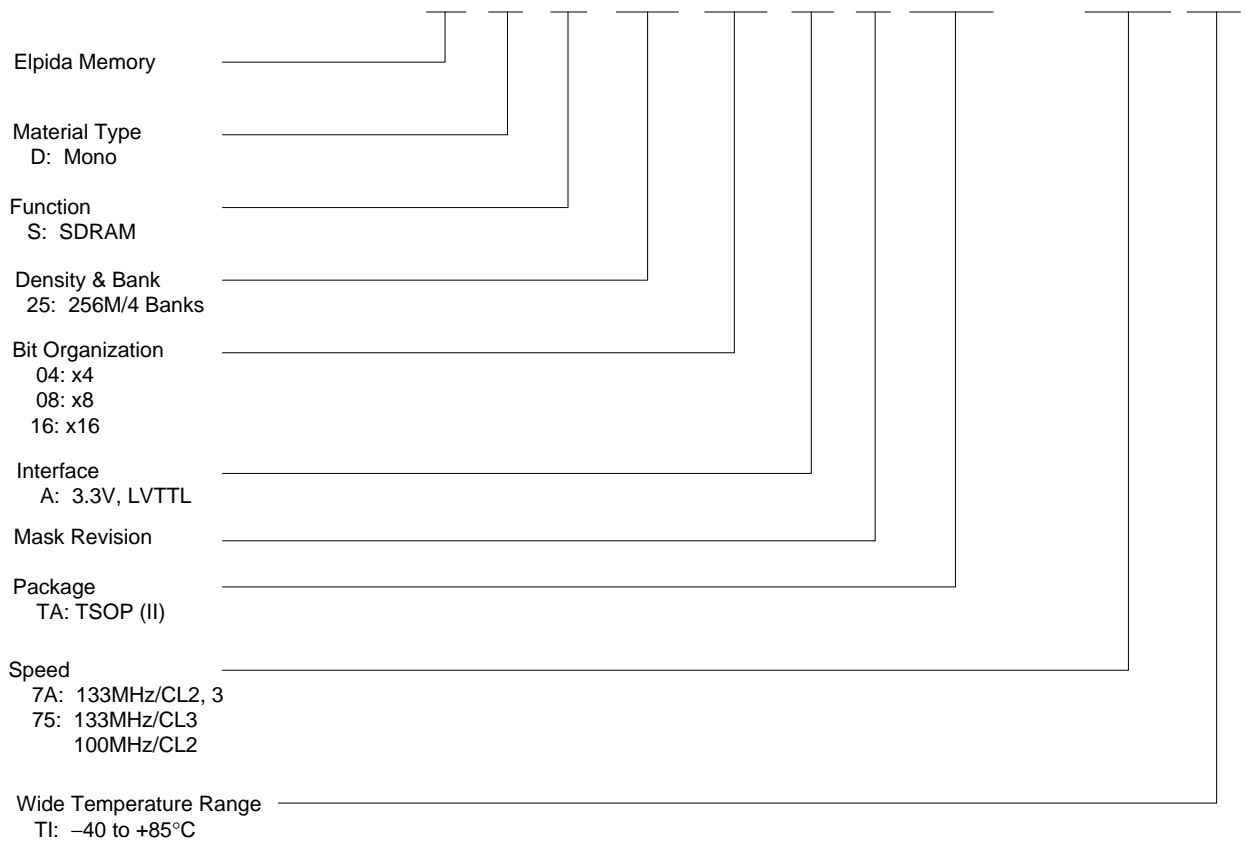

**CONTENTS**

Description ..... 1

Features ..... 1

Pin Configurations ..... 1

Ordering Information ..... 2

Part Number ..... 2

Electrical Specifications..... 4

Block Diagram ..... 8

Pin Function ..... 13

Command Operation ..... 15

Simplified State Diagram..... 23

Mode Register Configuration ..... 24

Power-up sequence ..... 25

Operation of the SDRAM ..... 26

Timing Waveforms ..... 42

Package Drawing ..... 48

Recommended Soldering Conditions..... 49

Revision History ..... 52

## Electrical Specifications

- All voltages are referenced to VSS (GND).
- After power up, wait more than 100  $\mu$ s and then, execute Power on sequence and CBR (auto) Refresh before proper device operation is achieved.

## Absolute Maximum Ratings

Parameter	Symbol	Rating	Unit	Note
Voltage on any pin relative to VSS	VT	-0.5 to VDD + 0.5 ( $\leq$ 4.6 (max.))	V	
Supply voltage relative to VSS	VDD	-0.5 to +4.6	V	
Short circuit output current	IOS	50	mA	
Power dissipation	PD	1.0	W	
Operating temperature	TA	-40 to +85	$^{\circ}$ C	
Storage temperature	Tstg	-55 to +125	$^{\circ}$ C	

Notes: 1. Respect to VSS.

## Caution

**Exposing the device to stress above those listed in Absolute Maximum Ratings could cause permanent damage. The device is not meant to be operated under conditions outside the limits described in the operational section of this specification. Exposure to Absolute Maximum Rating conditions for extended periods may affect device reliability.**

## Recommended Operating Conditions (TA = -40 to +85 $^{\circ}$ C)

Parameter	Symbol	min.	max.	Unit	Notes
Supply voltage	VDD, VDDQ	3.0	3.6	V	1, 2
	VSS, VSSQ	0	0	V	3
Input high voltage	VIH	2.0	VDD + 0.3	V	1, 4
Input low voltage	VIL	-0.3	0.8	V	1, 5

Notes: 1. All voltage referred to VSS.

2. The supply voltage with all VDD and VDDQ pins must be on the same level.
3. The supply voltage with all VSS and VSSQ pins must be on the same level.
4. VIH (max.) = VDD + 2.0 V for pulse width  $\leq$  3ns at VDD.
5. VIL (min.) = VSS - 2.0 V for pulse width  $\leq$  3ns at VSS.

## DC Characteristics 1 (TA = -40 to +85°C, VDD, VDDQ = 3.3V ± 0.3V, VSS, VSSQ = 0V)

Parameter	Symbol	Grade	max.			Unit	Test condition	Notes
			× 4	× 8	× 16			
Operating current	ICC1	-7A	130	130	135	mA	Burst length = 1 tRC = min.	1, 2, 3
	ICC1	-75	110	110	115	mA	Burst length = 1 tRC = min.	
Standby current in power down	ICC2P		3	3	3	mA	CKE = VIL, tCK = min.	6
Standby current in power down (input signal stable)	ICC2PS		2	2	2	mA	CKE = VIL, tCK = ∞	7
Standby current in non power down	ICC2N		20	20	20	mA	CKE, /CS = VIH, tCK = min.	4
Standby current in non power down (input signal stable)	ICC2NS		9	9	9	mA	CKE = VIH, tCK = ∞, /CS = VIH	8
Active standby current in power down	ICC3P		4	4	4	mA	CKE = VIL, tCK = min.	1, 2, 6
Active standby current in power down (input signal stable)	ICC3PS		3	3	3	mA	CKE = VIL, tCK = ∞	2, 7
Active standby current in non power down	ICC3N		30	30	30	mA	CKE, /CS = VIH, tCK = min.	1, 2, 4
Active standby current in non power down (input signal stable)	ICC3NS		15	15	15	mA	CKE = VIH, tCK = ∞, /CS = VIH	2, 8
Burst operating current	ICC4		130	135	145	mA	tCK = min., BL = 4	1, 2, 5
Refresh current	ICC5	-7A	250	250	250	mA	tRC = min.	3
	ICC5	-75	220	220	220	mA	tRC = min.	
Self refresh current	ICC6		3	3	3	mA	VIH ≥ VDD - 0.2V VIL ≤ 0.2V	

Notes: 1. ICC depends on output load condition when the device is selected. ICC (max.) is specified at the output open condition.

2. One bank operation.
3. Input signals are changed once per one clock.
4. Input signals are changed once per two clocks.
5. Input signals are changed once per four clocks.
6. After power down mode, CLK operating current.
7. After power down mode, no CLK operating current.
8. Input signals are VIH or VIL fixed.

**DC Characteristics 2 (TA = -40 to +85°C, VDD, VDDQ = 3.3V ± 0.3V, VSS, VSSQ = 0V)**

Parameter	Symbol	min.	max.	Unit	Test condition	Notes
Input leakage current	ILI	-1	1	μA	0 ≤ VIN ≤ VDD	
Output leakage current	ILO	-1.5	1.5	μA	0 ≤ VOUT ≤ VDD, DQ = disable	
Output high voltage	VOH	2.4	—	V	IOH = -4 mA	
Output low voltage	VOL	—	0.4	V	IOL = 4 mA	

**Pin Capacitance (TA = 25°C, VDD, VDDQ = 3.3V ± 0.3V)**

Parameter	Symbol	Pins	min.	Typ	max.	Unit	Notes
Input capacitance	C11	CLK	2.5	—	3.5	pF	1, 2, 4
	C12	Address, CKE, /CS, /RAS, /CAS, /WE, DQM,	2.5	—	3.8	pF	1, 2, 4
Data input/output capacitance	CI/O	DQ	4	—	6.5	pF	1, 2, 3, 4

Notes: 1. Capacitance measured with Boonton Meter or effective capacitance measuring method.

2. Measurement condition: f = 1MHz, 1.4V bias, 200mV swing.

3. DQM = VIH to disable DOUT.

4. This parameter is sampled and not 100% tested.

**AC Characteristics (TA = -40 to +85°C, VDD, VDDQ = 3.3V ± 0.3V, VSS, VSSQ = 0V)**

Parameter	Symbol	-7A	-75	max.	Unit	Notes
		min.	min.			
System clock cycle time	tCK	7.5	7.5	—	ns	1
CLK high pulse width	tCH	2.5	2.5	—	ns	1
CLK low pulse width	tCL	2.5	2.5	—	ns	1
Access time from CLK	tAC	—	—	5.4	ns	1, 2
Data-out hold time	tOH	2.7	2.7	—	ns	1, 2
CLK to Data-out low impedance	tLZ	1	1	—	ns	1, 2, 3
CLK to Data-out high impedance	tHZ	—	—	5.4	ns	1, 4
Input setup time	tSI	1.5	1.5	—	ns	1
Input hold time	tHI	0.8	0.8	—	ns	1
Ref/Active to Ref/Active command period	tRC	60	67.5	—	ns	1
Active to Precharge command period	tRAS	45	45	120000	ns	1
Active command to column command (same bank)	tRCD	15	20	—	ns	1
Precharge to active command period	tRP	15	20	—	ns	1
Write recovery or data-in to precharge lead time	tDPL	15	15	—	ns	1
Last data into active latency	tDAL	2CLK + 15ns	2CLK + 20ns	—		
Active (a) to Active (b) command period	tRRD	15	15	—	ns	1
Transition time (rise and fall)	tT	0.5	0.5	5	ns	
Refresh period (8192 refresh cycles)	tREF	—	—	64	ms	

Notes: 1. AC measurement assumes tT = 0.5ns. Reference level for timing of input signals is 1.4V.

2. Access time is measured at 1.4V. Load condition is CL = 50pF.

3. tLZ (min.) defines the time at which the outputs achieves the low impedance state.

4. tHZ (max.) defines the time at which the outputs achieves the high impedance state.

**Test Conditions**

- Input and output timing reference levels: 1.4V
- Input waveform and output load: See following figures

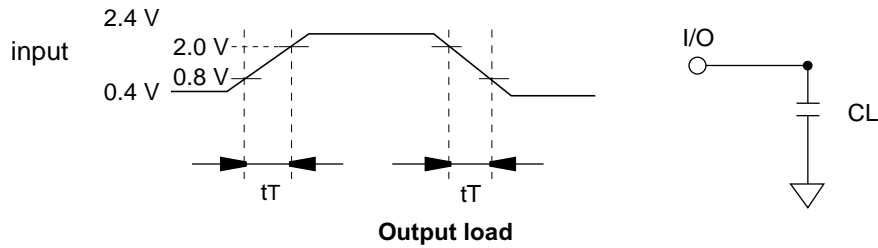

**Relationship Between Frequency and Minimum Latency**

Parameter		-7A	-75	
Frequency (MHz)		133		
tCK (ns)	Symbol	7.5	7.5	Notes
Active command to column command (same bank)	IRCD	2	3	1
Active command to active command (same bank)	IRC	8	9	1
Active command to precharge command (same bank)	IRAS	6	6	1
Precharge command to active command (same bank)	IRP	2	3	1
Write recovery or data-in to precharge command (same bank)	IDPL	2	2	1
Active command to active command (different bank)	IRRD	2	2	1
Self refresh exit time	ISREX	1	1	2
Last data in to active command (Auto precharge, same bank)	IDAL	4	5	= [IDPL + IRP]
Self refresh exit to command input	ISEC	8	9	= [IRC] 3
Precharge command to high impedance (CL = 2)	IHZP	2	2	
(CL = 3)	IHZP	3	3	
Last data out to active command (auto precharge) (same bank)	IAPR	1	1	
Last data out to precharge (early precharge) (CL = 2)	IEP	-1	-1	
(CL = 3)	IEP	-2	-2	
Column command to column command	ICCD	1	1	
Write command to data in latency	IWCD	0	0	
DQM to data in	IDID	0	0	
DQM to data out	IDOD	2	2	
CKE to CLK disable	ICLE	1	1	
Register set to active command	IMRD	2	2	
/CS to command disable	ICDD	0	0	
Power down exit to command input	IPEC	1	1	

Notes: 1. IRCD to IRRD are recommended value.

2. Be valid [DESL] or [NOP] at next command of self refresh exit.
3. Except [DESL] and [NOP]

**VIL/VIH Clamp**

This SDRAM component has VIL and VIH clamp for CLK, CKE, /CS, DQM and DQ pins.

**[Minimum VIL Clamp Current]**

VIL (V)	I (mA)
-2	-32
-1.8	-25
-1.6	-19
-1.4	-13
-1.2	-8
-1	-4
-0.9	-2
-0.8	-0.6
-0.6	0
-0.4	0
-0.2	0
0	0

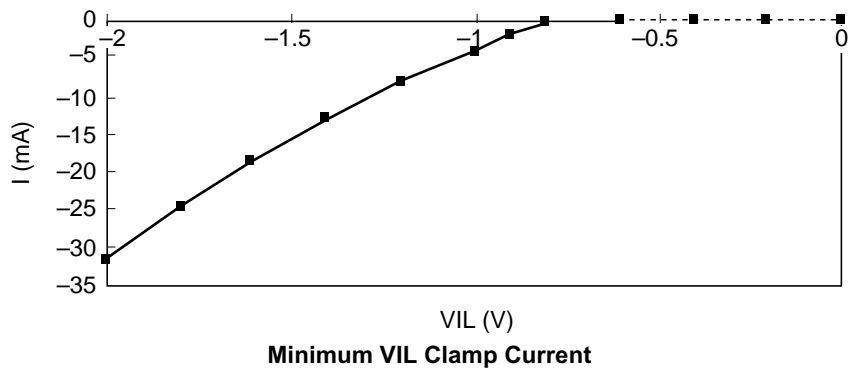

**[Minimum VIH Clamp Current]**

VIH (V)	I (mA)
VDD + 2	10
VDD + 1.8	8
VDD + 1.6	5.5
VDD + 1.4	3.5
VDD + 1.2	1.5
VDD + 1	0.3
VDD + 0.8	0
VDD + 0.6	0
VDD + 0.4	0
VDD + 0.2	0
VDD + 0	0

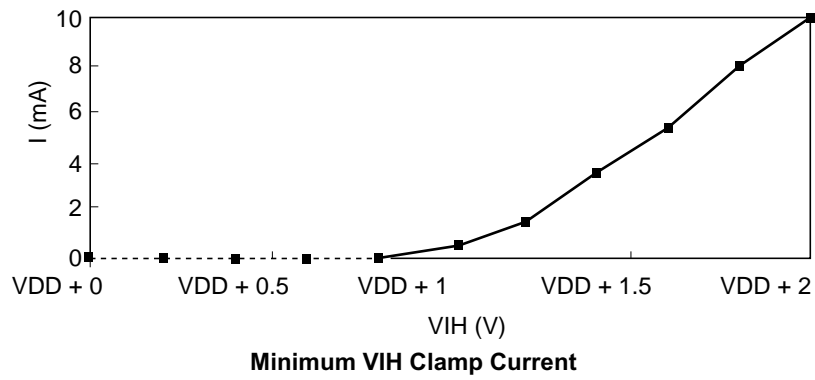

IOL/IOH Characteristics

[Output Low Current (IOL)]

VOUT (V)	IOL	
	min. (mA)	max. (mA)
0	0	0
0.4	27	71
0.65	41	108
0.85	51	134
1	58	151
1.4	70	188
1.5	72	194
1.65	75	203
1.8	77	209
1.95	77	212
3	80	220
3.45	81	223

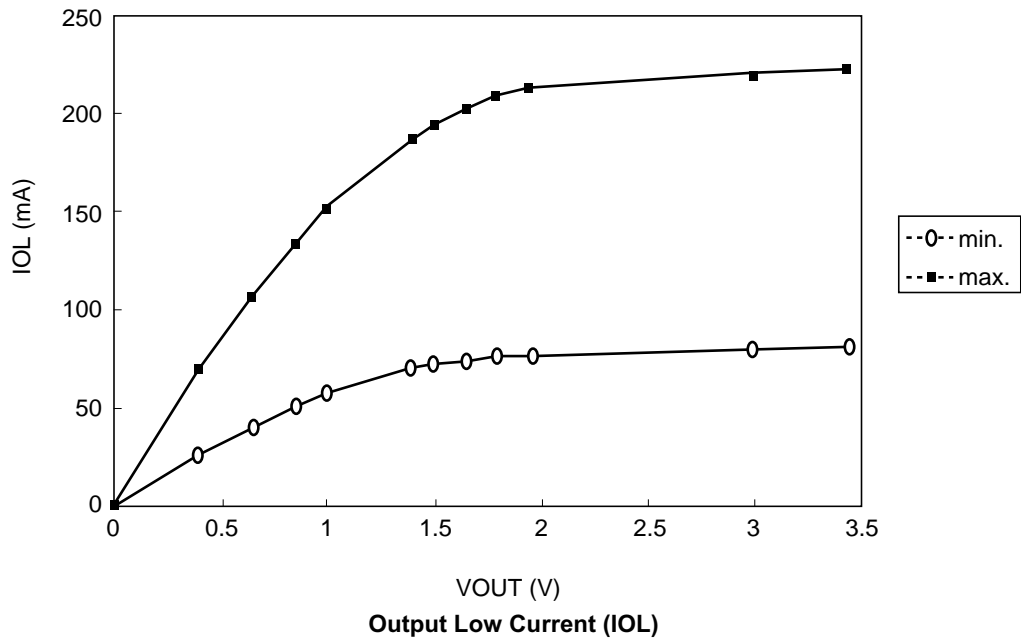

[Output High Current (IOH)]

VOUT (V)	IOH	
	min. (mA)	max. (mA)
3.45	—	-3
3.3	—	-28
3	0	-75
2.6	-21	-130
2.4	-34	-154
2	-59	-197
1.8	-67	-227
1.65	-73	-248
1.5	-78	-270
1.4	-81	-285
1	-89	-345
0	-93	-503

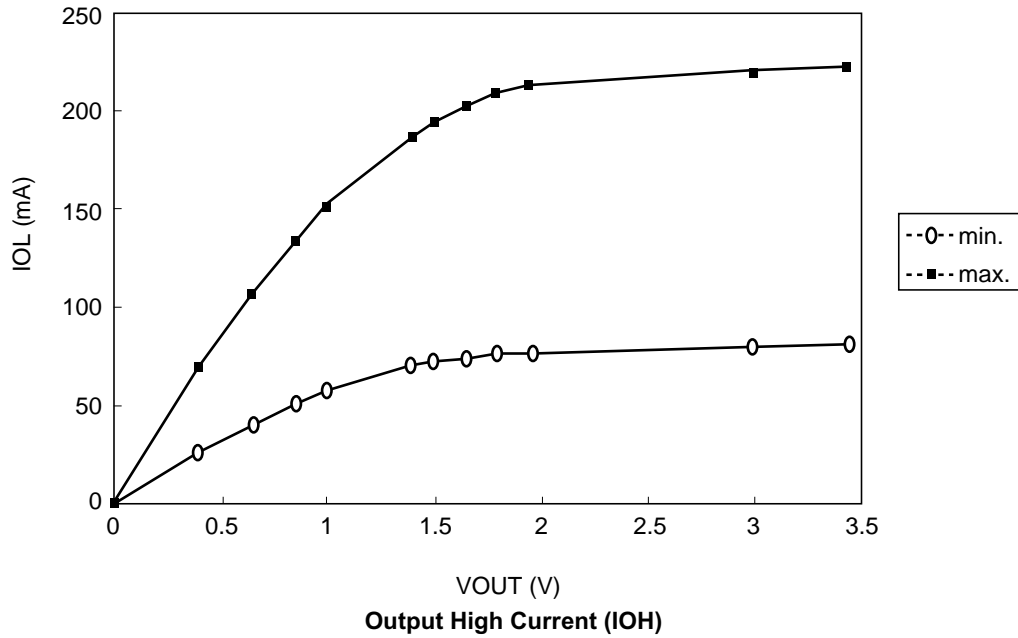

**Block Diagram**

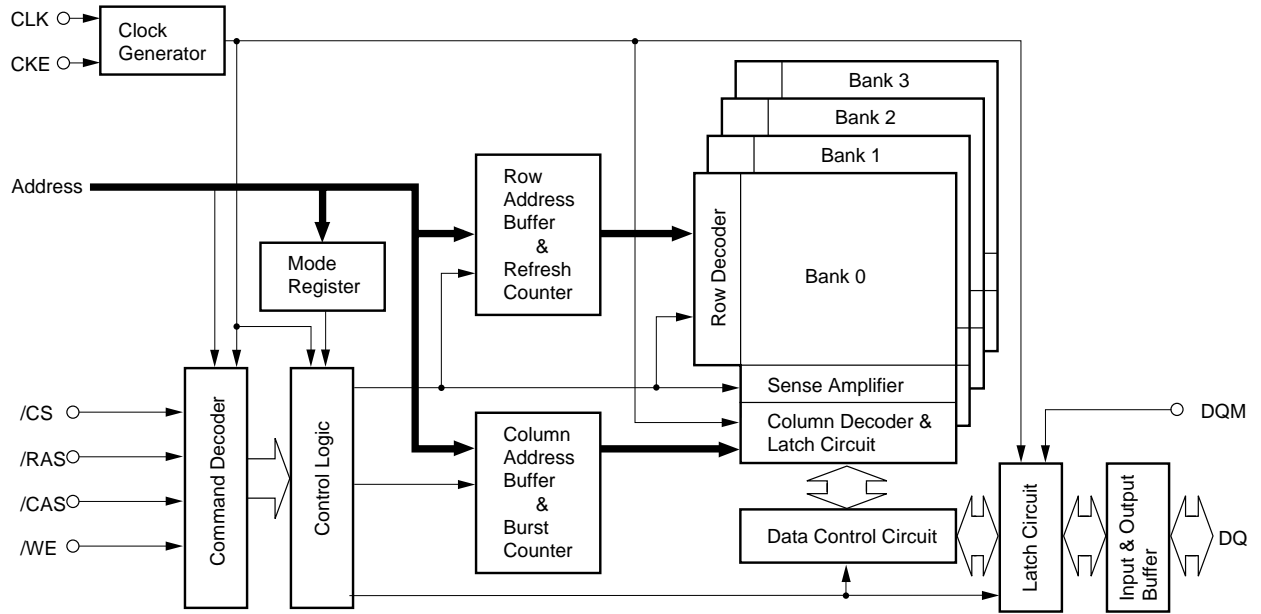

**Pin Function****CLK (input pin)**

CLK is the master clock input to this pin. The other input signals are referred at CLK rising edge.

**/CS (input pin)**

When /CS is Low, the command input cycle becomes valid. When /CS is High, all inputs are ignored. However, internal operations (bank active, burst operations, etc.) are held.

**/RAS, /CAS, and /WE (input pins)**

Although these pin names are the same as those of conventional DRAMs, they function in a different way. These pins define operation commands (read, write, etc.) depending on the combination of their voltage levels. For details, refer to the command operation section.

**A0 to A12 (input pins)**

Row address (AX0 to AX12) is determined by A0 to A12 at the bank active command cycle CLK rising edge. Column address is determined by A0 to A8, A9 or A11 (see Address Pins Table) at the read or write command cycle CLK rising edge. And this column address becomes burst access start address.

**[Address Pins Table]**

Part number	Address (A0 to A12)	
	Row address	Column address
EDS2504AP	AX0 to AX12	AY0 to AY9, AY11
EDS2508AP	AX0 to AX12	AY0 to AY9
EDS2516AP	AX0 to AX12	AY0 to AY8

A10 defines the precharge mode. When A10 = High at the precharge command cycle, all banks are precharged. But when A10 = Low at the precharge command cycle, only the bank that is selected by BA0 and BA1 (BS) is precharged. For details refer to the command operation section.

**BA0 and BA1 (input pin)**

BA0 and BA1 are bank select signal (BS). (See Bank Select Signal Table)

**[Bank Select Signal Table]**

	BA0	BA1
Bank 0	L	L
Bank 1	H	L
Bank 2	L	H
Bank 3	H	H

Remark: H: VIH. L: VIL. x: VIH or VIL

**CKE (input pin)**

This pin determines whether or not the next CLK is valid. If CKE is High, the next CLK rising edge is valid. If CKE is Low, the next CLK rising edge is invalid. This pin is used for power-down mode, clock suspend mode and self refresh mode.

## **DQM, UDQM and LDQM (input pins)**

DQM controls input/output buffers. In  $16M \times 16$  products, UDQM and LDQM control upper byte (DQ8 to DQ15) and lower byte (DQ0 to DQ7).

Read operation: If DQM is High, the output buffer becomes High-Z. If the DQM is Low, the output buffer becomes Low-Z. (The latency of DQM during reading is 2 clocks.)

Write operation: If DQM is High, the previous data is held (the new data is not written). If DQM is Low, the data is written. (The latency of DQM during writing is 0 clock.)

## **DQ0 to DQ15 (input/output pins)**

Data is input to and output from these pins (DQ0 to DQ3; EDS2504AP, DQ0 to DQ7; EDS2508AP, DQ0 to DQ15; EDS2516AP).

## **VDD, VSS, VDDQ, VSSQ (Power supply)**

VDD and VSS are power supply pins for internal circuits. VDDQ and VSSQ are power supply pins for the output buffers.

## Command Operation

### Command Truth Table

The SDRAM recognizes the following commands specified by the /CS, /RAS, /CAS, /WE and address pins.

Function	Symbol	CKE		/CS	/RAS	/CAS	/WE	BA1,BA0	A10	A0 to A12
		n – 1	n							
Device deselect	DESL	H	×	H	×	×	×	×	×	×
No operation	NOP	H	×	L	H	H	H	×	×	×
Burst stop	BST	H	×	L	H	H	L	×	×	×
Read	READ	H	×	L	H	L	H	V	L	V
Read with auto precharge	READA	H	×	L	H	L	H	V	H	V
Write	WRIT	H	×	L	H	L	L	V	L	V
Write with auto precharge	WRITA	H	×	L	H	L	L	V	H	V
Bank activate	ACT	H	×	L	L	H	H	V	V	V
Precharge select bank	PRE	H	×	L	L	H	L	V	L	×
Precharge all banks	PALL	H	×	L	L	H	L	×	H	×
Mode register set	MRS	H	×	L	L	L	L	L	L	V

Remark: H: VIH. L: VIL. ×: VIH or VIL

#### Device deselect command [DESL]

When this command is set (/CS is High), the SDRAM ignore command input at the clock. However, the internal status is held.

#### No operation [NOP]

This command is not an execution command. However, the internal operations continue.

#### Burst stop command [BST]

This command can stop the current burst operation.

#### Column address strobe and read command [READ]

This command starts a read operation. In addition, the start address of burst read is determined by the column address (see Address Pins Table in Pin Function) and the bank select address. After the read operation, the output buffer becomes High-Z.

#### Read with auto-precharge [READA]

This command automatically performs a precharge operation after a burst read with a burst length of 1, 2, 4 or 8.

#### Column address strobe and write command [WRIT]

This command starts a write operation. When the burst write mode is selected, the column address (see Address Pins Table in Pin Function) and the bank select address (BA0, BA1) become the burst write start address. When the single write mode is selected, data is only written to the location specified by the column address (see Address Pins Table in Pin Function) and the bank select address (BA0, BA1).

#### Write with auto-precharge [WRITA]

This command automatically performs a precharge operation after a burst write with a length of 1, 2, 4 or 8, or after a single write operation.

**Row address strobe and bank activate [ACT]**

This command activates the bank that is selected by BA0, BA1 and determines the row address (AX0 to AX12). (See Bank Select Signal Table)

**Precharge selected bank [PRE]**

This command starts precharge operation for the bank selected by BA0, BA1. (See Bank Select Signal Table)

**[Bank Select Signal Table]**

	BA0	BA1
Bank 0	L	L
Bank 1	H	L
Bank 2	L	H
Bank 3	H	H

Remark: H: VIH. L: VIL. x: VIH or VIL

**Precharge all banks [PALL]**

This command starts a precharge operation for all banks.

**Refresh [REF/SELF]**

This command starts the refresh operation. There are two types of refresh operation, the one is auto-refresh, and the other is self-refresh. For details, refer to the CKE truth table section.

**Mode register set [MRS]**

The SDRAM has a mode register that defines how it operates. The mode register is specified by the address pins (A0 to BA0 and BA1) at the mode register set cycle. For details, refer to the mode register configuration. After power on, the contents of the mode register are undefined, execute the mode register set command to set up the mode register.

**DQM Truth Table**

Commands	Symbol	CKE		DQM	
		n – 1	n	UDQM	LDQM
Write enable/output enable	ENB	H	×	L	
Write inhibit/output disable	MASK	H	×	H	
Upper byte write enable/output enable	ENBU	H	×	L	×
Lower byte write enable/output enable	ENBL	H	×	×	L
Upper byte write inhibit/output disable	MASKU	H	×	H	×
Lower byte write inhibit/output disable	MASKL	H	×	×	H

Remark: H: VIH. L: VIL. x: VIH or VIL  
 Write: IDID is needed.  
 Read: IDOD is needed.

**CKE Truth Table**

Current state	Function	Symbol	CKE						
			n – 1	n	/CS	/RAS	/CAS	/WE	Address
Activating	Clock suspend mode entry		H	L	×	×	×	×	×
Any	Clock suspend mode		L	L	×	×	×	×	×
Clock suspend	Clock suspend mode exit		L	H	×	×	×	×	×
Idle	CBR (auto) refresh command	REF	H	H	L	L	L	H	×
Idle	Self refresh entry	SELF	H	L	L	L	L	H	×
Self refresh	Self refresh exit		L	H	L	H	H	H	×
			L	H	H	×	×	×	×
Idle	Power down entry		H	L	L	H	H	H	×
			H	L	H	×	×	×	×
Power down	Power down exit		L	H	H	×	×	×	×
			L	H	L	H	H	H	×

Remark: H: VIH. L: VIL. x: VIH or VIL

## Function Truth Table

The following table shows the operations that are performed when each command is issued in each mode of the SDRAM.

The following table assumes that CKE is high.

Current state	/CS	/RAS	/CAS	/WE	Address	Command	Operation
Precharge	H	×	×	×	×	DESL	Enter IDLE after tRP
	L	H	H	H	×	NOP	Enter IDLE after tRP
	L	H	H	L	×	BST	ILLEGAL
	L	H	L	H	BA, CA, A10	READ/READA	ILLEGAL* <sup>3</sup>
	L	H	L	L	BA, CA, A10	WRIT/WRITA	ILLEGAL* <sup>3</sup>
	L	L	H	H	BA, RA	ACT	ILLEGAL* <sup>3</sup>
	L	L	H	L	BA, A10	PRE, PALL	NOP* <sup>5</sup>
	L	L	L	H	×	REF, SELF	ILLEGAL
	L	L	L	L	MODE	MRS	ILLEGAL
Idle	H	×	×	×	×	DESL	NOP
	L	H	H	H	×	NOP	NOP
	L	H	H	L	×	BST	ILLEGAL
	L	H	L	H	BA, CA, A10	READ/READA	ILLEGAL* <sup>4</sup>
	L	H	L	L	BA, CA, A10	WRIT/WRITA	ILLEGAL* <sup>4</sup>
	L	L	H	H	BA, RA	ACT	Bank and row active
	L	L	H	L	BA, A10	PRE, PALL	NOP
	L	L	L	H	×	REF, SELF	Refresh
	L	L	L	L	MODE	MRS	Mode register set* <sup>8</sup>
Row active	H	×	×	×	×	DESL	NOP
	L	H	H	H	×	NOP	NOP
	L	H	H	L	×	BST	ILLEGAL
	L	H	L	H	BA, CA, A10	READ/READA	Begin read* <sup>6</sup>
	L	H	L	L	BA, CA, A10	WRIT/WRITA	Begin write* <sup>6</sup>
	L	L	H	H	BA, RA	ACT	Other bank active ILLEGAL on same bank* <sup>2</sup>
	L	L	H	L	BA, A10	PRE, PALL	Precharge* <sup>7</sup>
	L	L	L	H	×	REF, SELF	ILLEGAL
	L	L	L	L	MODE	MRS	ILLEGAL
Read	H	×	×	×	×	DESL	Continue burst to end
	L	H	H	H	×	NOP	Continue burst to end
	L	H	H	L	×	BST	Burst stop
	L	H	L	H	BA, CA, A10	READ/READA	Continue burst read to /CAS latency and New read
	L	H	L	L	BA, CA, A10	WRIT/WRITA	Term burst read/start write
	L	L	H	H	BA, RA	ACT	Other bank active ILLEGAL on same bank* <sup>2</sup>
	L	L	H	L	BA, A10	PRE, PALL	Term burst read and Precharge
	L	L	L	H	×	REF, SELF	ILLEGAL
	L	L	L	L	MODE	MRS	ILLEGAL

Current state	/CS	/RAS	/CAS	/WE	Address	Command	Operation
Read with auto-precharge	H	×	×	×	×	DESL	Continue burst to end and precharge
	L	H	H	H	×	NOP	Continue burst to end and precharge
	L	H	H	L	×	BST	ILLEGAL
	L	H	L	H	BA, CA, A10	READ/READA	ILLEGAL <sup>*3</sup>
	L	H	L	L	BA, CA, A10	WRIT/WRITA	ILLEGAL <sup>*3</sup>
	L	L	H	H	BA, RA	ACT	Other bank active ILLEGAL on same bank <sup>*2</sup>
	L	L	H	L	BA, A10	PRE, PALL	ILLEGAL <sup>*3</sup>
	L	L	L	H	×	REF, SELF	ILLEGAL
	L	L	L	L	MODE	MRS	ILLEGAL
Write	H	×	×	×	×	DESL	Continue burst to end
	L	H	H	H	×	NOP	Continue burst to end
	L	H	H	L	×	BST	Burst stop
	L	H	L	H	BA, CA, A10	READ/READA	Term burst and New read
	L	H	L	L	BA, CA, A10	WRIT/WRITA	Term burst and New write
	L	L	H	H	BA, RA	ACT	Other bank active ILLEGAL on same bank <sup>*3</sup>
	L	L	H	L	BA, A10	PRE, PALL	Term burst write and Precharge <sup>*1</sup>
	L	L	L	H	×	REF, SELF	ILLEGAL
	L	L	L	L	MODE	MRS	ILLEGAL
Write with auto-precharge	H	×	×	×	×	DESL	Continue burst to end and precharge
	L	H	H	H	×	NOP	Continue burst to end and precharge
	L	H	H	L	×	BST	ILLEGAL
	L	H	L	H	BA, CA, A10	READ/READA	ILLEGAL <sup>*3</sup>
	L	H	L	L	BA, CA, A10	WRIT/WRITA	ILLEGAL <sup>*3</sup>
	L	L	H	H	BA, RA	ACT	Other bank active ILLEGAL on same bank <sup>*3</sup>
	L	L	H	L	BA, A10	PRE, PALL	ILLEGAL <sup>*3</sup>
	L	L	L	H	×	REF, SELF	ILLEGAL
	L	L	L	L	MODE	MRS	ILLEGAL
Refresh (auto-refresh)	H	×	×	×	×	DESL	Enter IDLE after tRC
	L	H	H	H	×	NOP	Enter IDLE after tRC
	L	H	H	L	×	BST	ILLEGAL
	L	H	L	H	BA, CA, A10	READ/READA	ILLEGAL <sup>*4</sup>
	L	H	L	L	BA, CA, A10	WRIT/WRITA	ILLEGAL <sup>*4</sup>
	L	L	H	H	BA, RA	ACT	ILLEGAL <sup>*4</sup>
	L	L	H	L	BA, A10	PRE, PALL	ILLEGAL <sup>*4</sup>
	L	L	L	H	×	REF, SELF	ILLEGAL
	L	L	L	L	MODE	MRS	ILLEGAL

Current state	/CS	/RAS	/CAS	/WE	Address	Command	Operation
Mode register set	H	×	×	×	×	DESL	NOP
	L	H	H	H	×	NOP	NOP
	L	H	H	L	×	BST	ILLEGAL
	L	H	L	H	BA, CA, A10	READ/READA	ILLEGAL* <sup>4</sup>
	L	H	L	L	BA, CA, A10	WRIT/WRITA	ILLEGAL* <sup>4</sup>
	L	L	H	H	BA, RA	ACT	Bank and row active* <sup>9</sup>
	L	L	H	L	BA, A10	PRE, PALL	NOP
	L	L	L	H	×	REF, SELF	Refresh* <sup>9</sup>
	L	L	L	L	MODE	MRS	Mode register set* <sup>8</sup>

Remark: H: VIH. L: VIL. ×: VIH or VIL

Notes: 1.An interval of tDPL is required between the final valid data input and the precharge command.

2. If tRRD is not satisfied, this operation is illegal.
3. Illegal for same bank, except for another bank.
4. Illegal for all banks.
5. NOP for same bank, except for another bank.
6. Illegal if tRCD is not satisfied.
7. Illegal if tRAS is not satisfied.
8. MRS command must be issued after DOUT finished, in case of DOUT remaining.
9. Illegal if IMRD is not satisfied.

## Command Truth Table for CKE

Current State	CKE							Operation	Notes
	n – 1	n	/CS	/RAS	/CAS	/WE	Address		
Self refresh	H	x	x	x	x	x	x	INVALID, CLK (n – 1) would exit self refresh	
	L	H	H	x	x	x	x	Self refresh recovery	
	L	H	L	H	H	x	x	Self refresh recovery	
	L	H	L	H	L	x	x	ILLEGAL	
	L	H	L	L	x	x	x	ILLEGAL	
	L	L	x	x	x	x	x	Continue self refresh	
Self refresh recovery	H	H	H	x	x	x	x	Idle after t <sub>RC</sub>	
	H	H	L	H	H	x	x	Idle after t <sub>RC</sub>	
	H	H	L	H	L	x	x	ILLEGAL	
	H	H	L	L	x	x	x	ILLEGAL	
	H	L	H	x	x	x	x	ILLEGAL	
	H	L	L	H	H	x	x	ILLEGAL	
	H	L	L	H	L	x	x	ILLEGAL	
	H	L	L	L	x	x	x	ILLEGAL	
Power down	H	x	x	x	x	x		INVALID, CLK (n – 1) would exit power down	
	L	H	H	x	x	x	x	EXIT power down	
	L	H	L	H	H	H	x	EXIT power down	
	L	L	x	x	x	x	x	Continue power down mode	
All banks idle	H	H	H	x	x	x		Refer to operations in Function Truth Table	
	H	H	L	H	x	x		Refer to operations in Function Truth Table	
	H	H	L	L	H	x		Refer to operations in Function Truth Table	
	H	H	L	L	L	H	x	CBR (auto) Refresh	
	H	H	L	L	L	L	OPCODE	Refer to operations in Function Truth Table	
	H	L	H	x	x	x		Begin power down next cycle	
	H	L	L	H	x	x		Refer to operations in Function Truth Table	
	H	L	L	L	H	x		Refer to operations in Function Truth Table	
	H	L	L	L	L	H	x	Self refresh	1
	H	L	L	L	L	L	OPCODE	Refer to operations in Function Truth Table	
	L	H	x	x	x	x	x	Exit power down next cycle	
	L	L	x	x	x	x	x	Power down	1
	Row active	H	x	x	x	x	x	x	Refer to operations in Function Truth Table
L		x	x	x	x	x	x	Clock suspend	1
Any state other than listed above	H	H	x	x	x	x		Refer to operations in Function Truth Table	
	H	L	x	x	x	x	x	Begin clock suspend next cycle	2
	L	H	x	x	x	x	x	Exit clock suspend next cycle	
	L	L	x	x	x	x	x	Maintain clock suspend	

Remark: H: VIH. L: VIL. x: VIH or VIL

Notes: 1. Self refresh can be entered only from the all banks idle state. Power down can be entered only from all banks idle. Clock suspend can be entered only from following states, row active, read, read with auto-precharge, write and write with auto precharge.

2. Must be legal command as defined in Function Truth Table.

**Clock suspend mode entry**

The SDRAM enters clock suspend mode from active mode by setting CKE to Low. If command is input in the clock suspend mode entry cycle, the command is valid. The clock suspend mode changes depending on the current status (1 clock before) as shown below.

**ACTIVE clock suspend**

This suspend mode ignores inputs after the next clock by internally maintaining the bank active status.

**READ suspend and READ with Auto-precharge suspend**

The data being output is held (and continues to be output).

**WRITE suspend and WRIT with Auto-precharge suspend**

In this mode, external signals are not accepted. However, the internal state is held.

**Clock suspend**

During clock suspend mode, keep the CKE to Low.

**Clock suspend mode exit**

The SDRAM exits from clock suspend mode by setting CKE to High during the clock suspend state.

**IDLE**

In this state, all banks are not selected, and completed precharge operation.

**Auto-refresh command [REF]**

When this command is input from the IDLE state, the SDRAM starts auto-refresh operation. (The auto-refresh is the same as the CBR refresh of conventional DRAMs.) During the auto-refresh operation, refresh address and bank select address are generated inside the SDRAM. For every auto-refresh cycle, the internal address counter is updated. Accordingly, 8192 times are required to refresh the entire memory. Before executing the auto-refresh command, all the banks must be in the IDLE state. In addition, since the precharge for all banks is automatically performed after auto-refresh, no precharge command is required after auto-refresh.

**Self-refresh entry [SELF]**

When this command is input during the IDLE state, the SDRAM starts self-refresh operation. After the execution of this command, self-refresh continues while CKE is Low. Since self-refresh is performed internally and automatically, external refresh operations are unnecessary.

**Power down mode entry**

When this command is executed during the IDLE state, the SDRAM enters power down mode. In power down mode, power consumption is suppressed by cutting off the initial input circuit.

**Self-refresh exit**

When this command is executed during self-refresh mode, the SDRAM can exit from self-refresh mode. After exiting from self-refresh mode, the SDRAM enters the IDLE state.

**Power down exit**

When this command is executed at the power down mode, the SDRAM can exit from power down mode. After exiting from power down mode, the SDRAM enters the IDLE state.

Simplified State Diagram

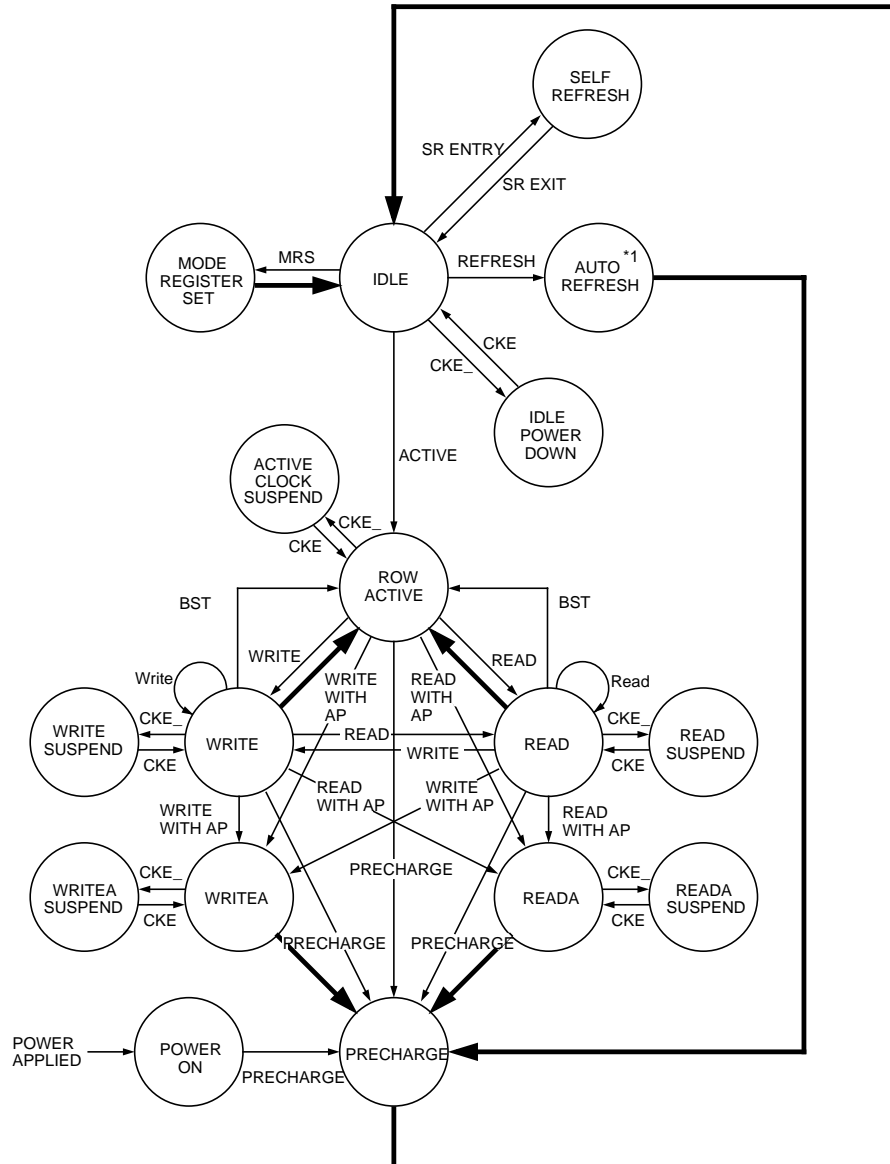

Automatic transition after completion of command.  
 Transition resulting from command input.

Note: 1. After the auto-refresh operation, precharge operation is performed automatically and enter the IDLE state.

**Mode Register Configuration**

The mode register is set by the input to the address pins (A0 to A12, BA0 and BA1) during mode register set cycles. The mode register consists of five sections, each of which is assigned to address pins.

BA1, BA0, A8, A9, A10, A11, A12: (OPCODE): The SDRAM has two types of write modes. One is the burst write mode, and the other is the single write mode. These bits specify write mode.

Burst read and burst write: Burst write is performed for the specified burst length starting from the column address specified in the write cycle.

Burst read and single write: Data is only written to the column address specified during the write cycle, regardless of the burst length.

A7: Keep this bit Low at the mode register set cycle. If this pin is high, the vendor test mode is set.

A6, A5, A4: (LMODE): These pins specify the /CAS latency.

A3: (BT): A burst type is specified.

A2, A1, A0: (BL): These pins specify the burst length.

BA1	BA0	A12	A11	A10	A9	A8	A7	A6	A5	A4	A3	A2	A1	A0
OPCODE							0	LMODE			BT	BL		

A6	A5	A4	CAS latency
0	0	0	R
0	0	1	R
0	1	0	2
0	1	1	3
1	X	X	R

A3	Burst type
0	Sequential
1	Interleave

A2	A1	A0	Burst length	
			BT=0	BT=1
0	0	0	1	1
0	0	1	2	2
0	1	0	4	4
0	1	1	8	8
1	0	0	R	R
1	0	1	R	R
1	1	0	R	R
1	1	1	R	R

BA1	BA0	A12	A11	A10	A9	A8	Write mode
0	0	0	0	0	0	0	Burst read and burst write
X	X	X	X	X	0	1	R
X	X	X	X	X	1	0	Burst read and single write
X	X	X	X	X	1	1	R

R is Reserved (inhibit)  
X: 0 or 1

**Mode Register Set Timing**

Burst length = 2			Burst length = 4				
Starting Ad.		Addressing(decimal)		Starting Ad.		Addressing(decimal)	
A0		Sequential	Interleave	A1	A0	Sequential	Interleave
0		0, 1,	0, 1,	0	0	0, 1, 2, 3,	0, 1, 2, 3,
1		1, 0,	1, 0,	0	1	1, 2, 3, 0,	1, 0, 3, 2,
				1	0	2, 3, 0, 1,	2, 3, 0, 1,
				1	1	3, 0, 1, 2,	3, 2, 1, 0,

Burst length = 8				
Starting Ad.			Addressing(decimal)	
A2	A1	A0	Sequential	Interleave
0	0	0	0, 1, 2, 3, 4, 5, 6, 7,	0, 1, 2, 3, 4, 5, 6, 7,
0	0	1	1, 2, 3, 4, 5, 6, 7, 0,	1, 0, 3, 2, 5, 4, 7, 6,
0	1	0	2, 3, 4, 5, 6, 7, 0, 1,	2, 3, 0, 1, 6, 7, 4, 5,
0	1	1	3, 4, 5, 6, 7, 0, 1, 2,	3, 2, 1, 0, 7, 6, 5, 4,
1	0	0	4, 5, 6, 7, 0, 1, 2, 3,	4, 5, 6, 7, 0, 1, 2, 3,
1	0	1	5, 6, 7, 0, 1, 2, 3, 4,	5, 4, 7, 6, 1, 0, 3, 2,
1	1	0	6, 7, 0, 1, 2, 3, 4, 5,	6, 7, 4, 5, 2, 3, 0, 1,
1	1	1	7, 0, 1, 2, 3, 4, 5, 6,	7, 6, 5, 4, 3, 2, 1, 0,

**Burst Sequence**

**Power-up sequence**

**Power-up sequence**

The SDRAM should be goes on the following sequence with power up.

The CLK, CKE, /CS, DQM and DQ pins keep low till power stabilizes.

The CLK pin is stabilized within 100 μs after power stabilizes before the following initialization sequence.

The CKE and DQM is driven to high between power stabilizes and the initialization sequence.

This SDRAM has VDD clamp diodes for CLK, CKE, /CS DQM and DQ pins. If these pins go high before power up, the large current flows from these pins to VDD through the diodes.

**Initialization sequence**

When 200 μs or more has past after the above power-up sequence, all banks must be precharged using the precharge command (PALL). After tRP delay, set 8 or more auto refresh commands (REF). Set the mode register set command (MRS) to initialize the mode register. We recommend that by keeping DQM and CKE to High, the output buffer becomes High-Z during Initialization sequence, to avoid DQ bus contention on memory system formed with a number of device.

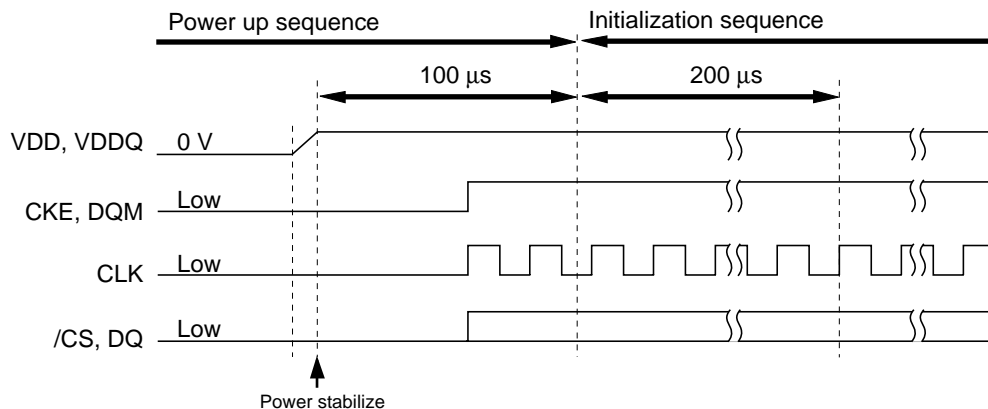

**Power-up sequence and Initialization sequence**

**Operation of the SDRAM**

**Read/Write Operations**

**Bank active**

Before executing a read or write operation, the corresponding bank and the row address must be activated by the bank active (ACT) command. An interval of tRCD is required between the bank active command input and the following read/write command input.

**Read operation**

A read operation starts when a read command is input. Output buffer becomes Low-Z in the (/CAS Latency - 1) cycle after read command set. The SDRAM can perform a burst read operation.

The burst length can be set to 1, 2, 4 and 8. The start address for a burst read is specified by the column address and the bank select address at the read command set cycle. In a read operation, data output starts after the number of clocks specified by the /CAS Latency. The /CAS Latency can be set to 2 or 3.

When the burst length is 1, 2, 4 and 8 the DOUT buffer automatically becomes High-Z at the next clock after the successive burst-length data has been output.

The /CAS latency and burst length must be specified at the mode register.

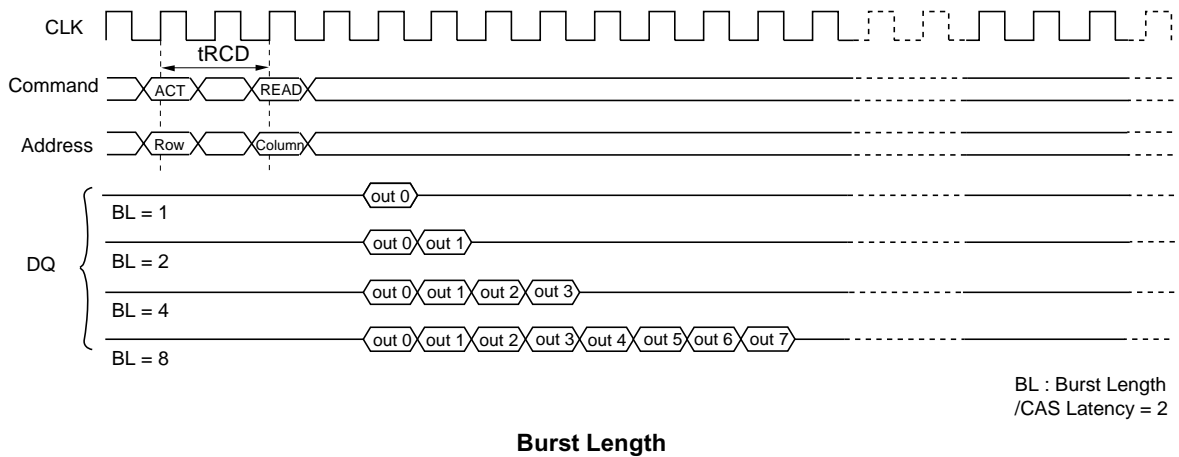
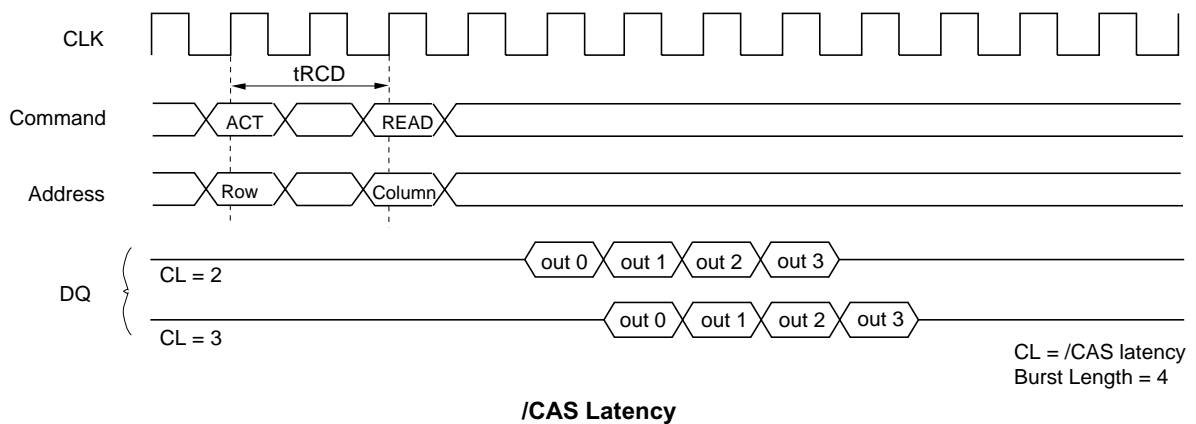

**Write operation**

Burst write or single write mode is selected by the OPCODE of the mode register.

1. Burst write: A burst write operation is enabled by setting OPCODE (A9, A8) to (0, 0). A burst write starts in the same clock as a write command set. (The latency of data input is 0 clock.) The burst length can be set to 1, 2, 4 and 8, like burst read operations. The write start address is specified by the column address and the bank select address at the write command set cycle.

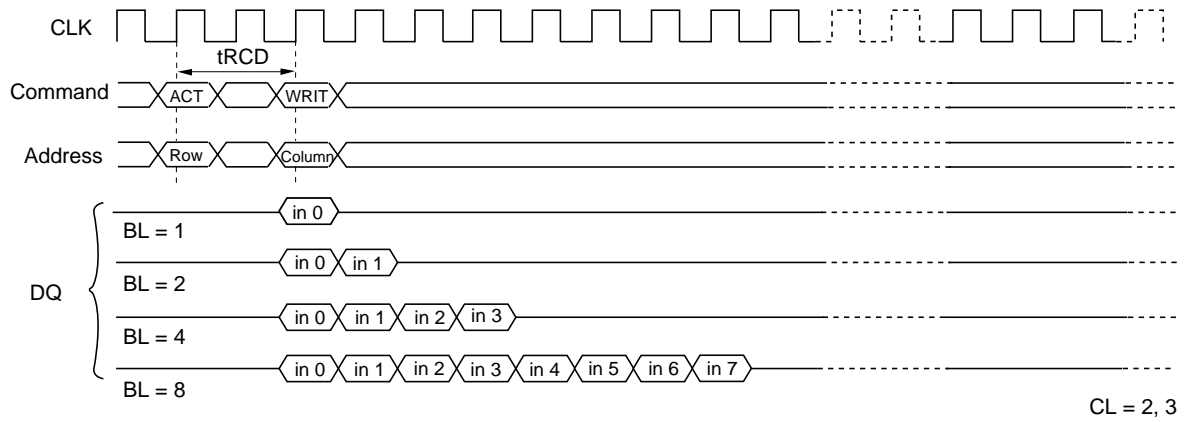

**Burst write**

2. Single write: A single write operation is enabled by setting OPCODE (A9, A8) to (1, 0). In a single write operation, data is only written to the column address and the bank select address specified by the write command set cycle without regard to the burst length setting. (The latency of data input is 0 clock).

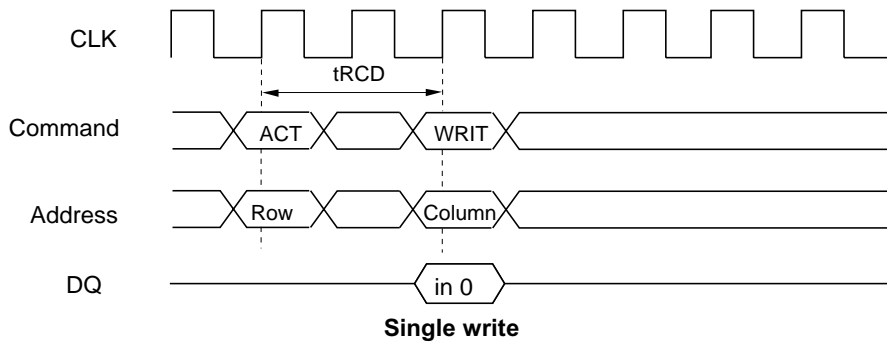

**Auto Precharge**

**Read with auto-precharge**

In this operation, since precharge is automatically performed after completing a read operation, a precharge command need not be executed after each read operation. The command executed for the same bank after the execution of this command must be the bank active (ACT) command. In addition, an interval defined by IAPR is required before execution of the next command.

**[Clock cycle time]**

/CAS latency	Precharge start cycle
3	2 cycle before the final data is output
2	1 cycle before the final data is output

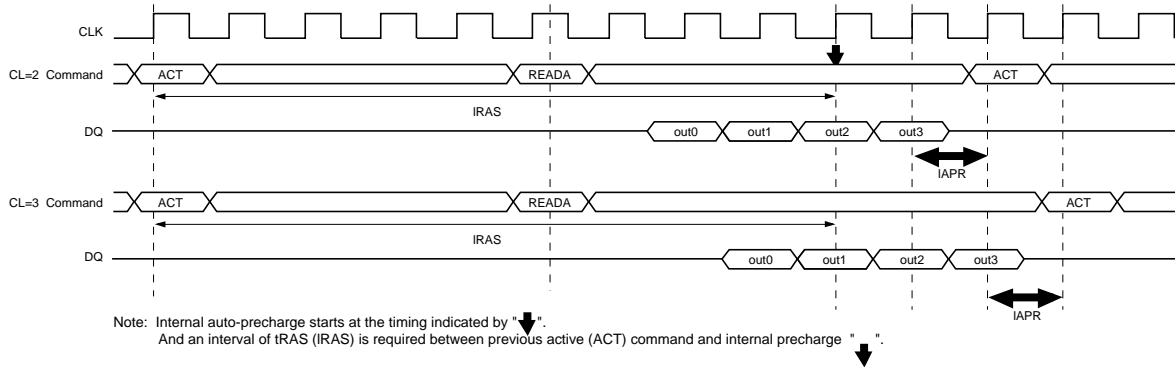

**Burst Read (BL = 4)**

**Write with auto-precharge**

In this operation, since precharge is automatically performed after completing a burst write or single write operation, a precharge command need not be executed after each write operation. The command executed for the same bank after the execution of this command must be the bank active (ACT) command. In addition, an interval of IDAL is required between the final valid data input and input of next command.

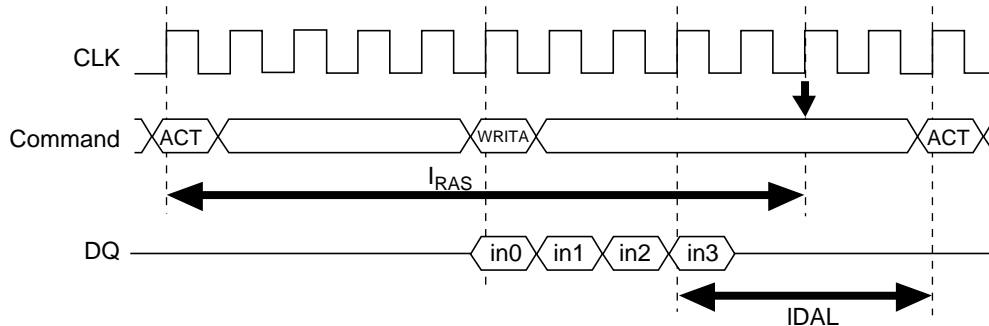

Note: Internal auto-precharge starts at the timing indicated by "↓".  
and an interval of tRAS (IRAS) is required between previous active (ACT) command and internal precharge "↓".

**Burst Write (BL = 4)**

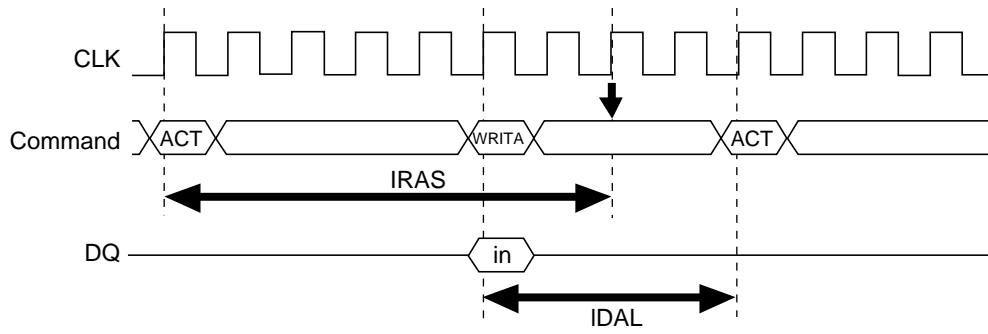

Note: Internal auto-precharge starts at the timing indicated by "↓".  
 and an interval of tRAS (IRAS) is required between previous active (ACT) command  
 and internal precharge "↓".

**Single Write**

**Burst Stop Command**

During a read cycle, when the burst stop command is issued, the burst read data are terminated and the data bus goes to High-Z after the /CAS latency from the burst stop command.

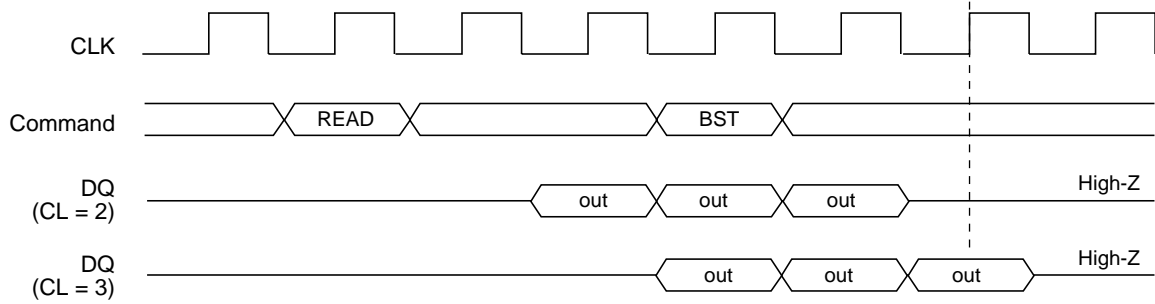

**Burst Stop at Read**

During a write cycle, when the burst stop command is issued, the burst write data are terminated and data bus goes to High-Z at the same clock with the burst stop command.

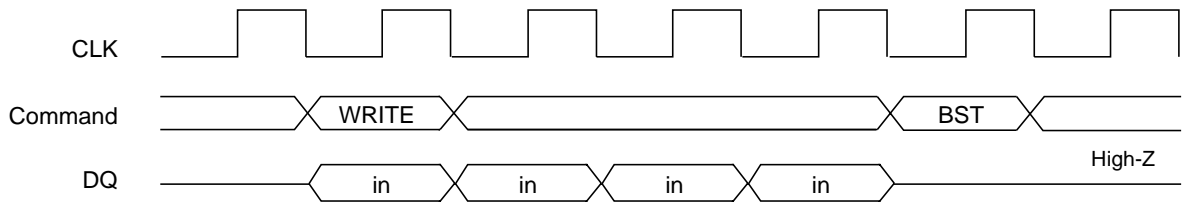

**Burst Stop at Write**

**Command Intervals**

**Read command to Read command interval**

1. Same bank, same ROW address: When another read command is executed at the same ROW address of the same bank as the preceding read command execution, the second read can be performed after an interval of no less than 1 clock. Even when the first command is a burst read that is not yet finished, the data read by the second command will be valid.

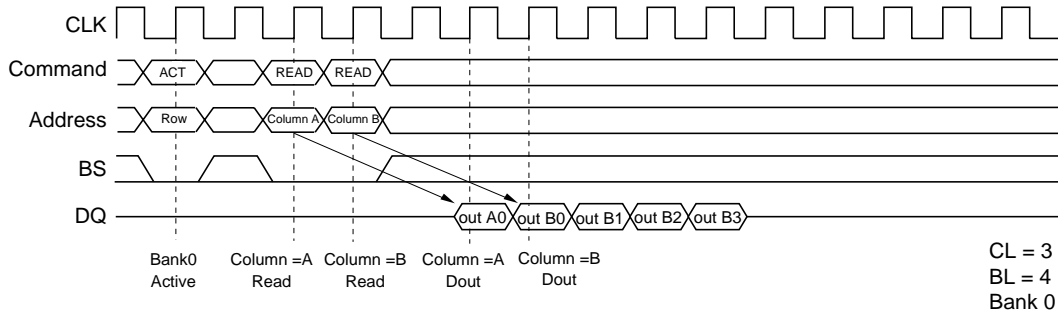

**READ to READ Command Interval (same ROW address in same bank)**

2. Same bank, different ROW address: When the ROW address changes on same bank, consecutive read commands cannot be executed; it is necessary to separate the two read commands with a precharge command and a bank active command.
3. Different bank: When the bank changes, the second read can be performed after an interval of no less than 1 clock, provided that the other bank is in the bank active state. Even when the first command is a burst read that is not yet finished, the data read by the second command will be valid.

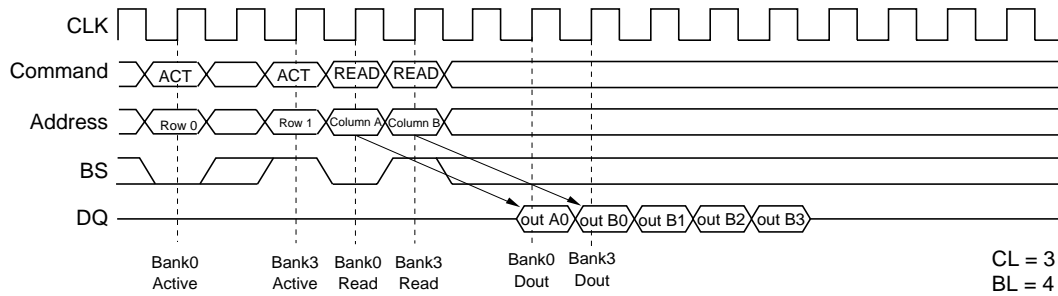

**READ to READ Command Interval (different bank)**

**Write command to Write command interval**

1. Same bank, same ROW address: When another write command is executed at the same ROW address of the same bank as the preceding write command, the second write can be performed after an interval of no less than 1 clock. In the case of burst writes, the second write command has priority.

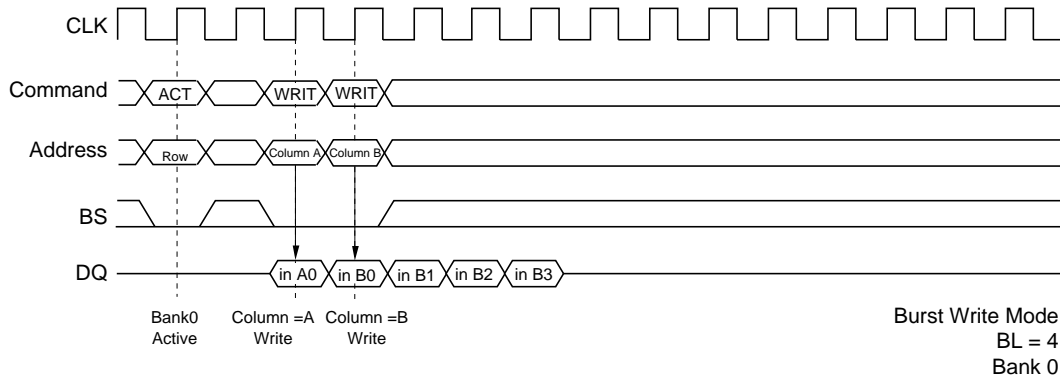

**WRITE to WRITE Command Interval (same ROW address in same bank)**

2. Same bank, different ROW address: When the ROW address changes, consecutive write commands cannot be executed; it is necessary to separate the two write commands with a precharge command and a bank active command.
3. Different bank: When the bank changes, the second write can be performed after an interval of no less than 1 clock, provided that the other bank is in the bank active state. In the case of burst write, the second write command has priority.

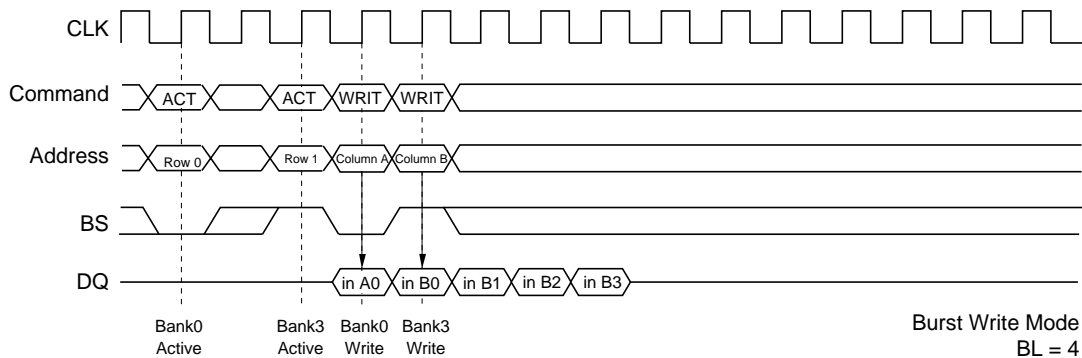

**WRITE to WRITE Command Interval (different bank)**

**Read command to Write command interval**

1. Same bank, same ROW address: When the write command is executed at the same ROW address of the same bank as the preceding read command, the write command can be performed after an interval of no less than 1 clock. However, DQM must be set High so that the output buffer becomes High-Z before data input.

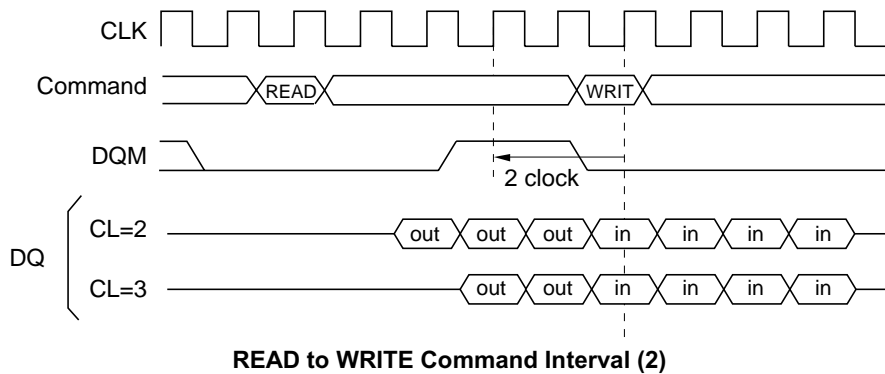
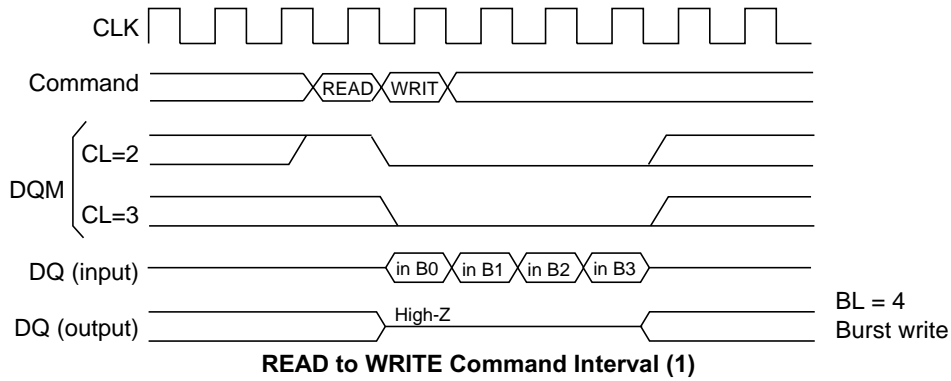

2. Same bank, different ROW address: When the ROW address changes, consecutive write commands cannot be executed; it is necessary to separate the two commands with a precharge command and a bank active command.
3. Different bank: When the bank changes, the write command can be performed after an interval of no less than 1 cycle, provided that the other bank is in the bank active state. However, DQM must be set High so that the output buffer becomes High-Z before data input.

**Write command to Read command interval:**

1. Same bank, same ROW address: When the read command is executed at the same ROW address of the same bank as the preceding write command, the read command can be performed after an interval of no less than 1 clock. However, in the case of a burst write, data will continue to be written until one clock before the read command is executed.

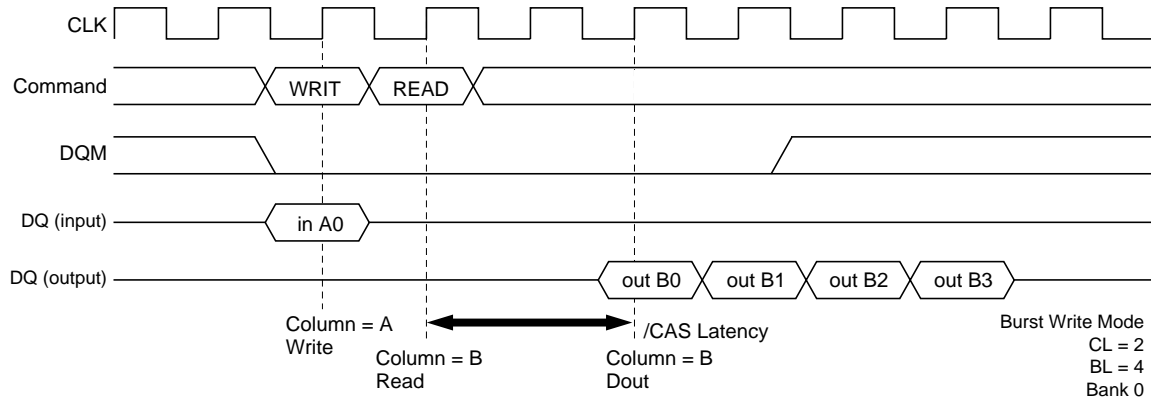

**WRITE to READ Command Interval (1)**

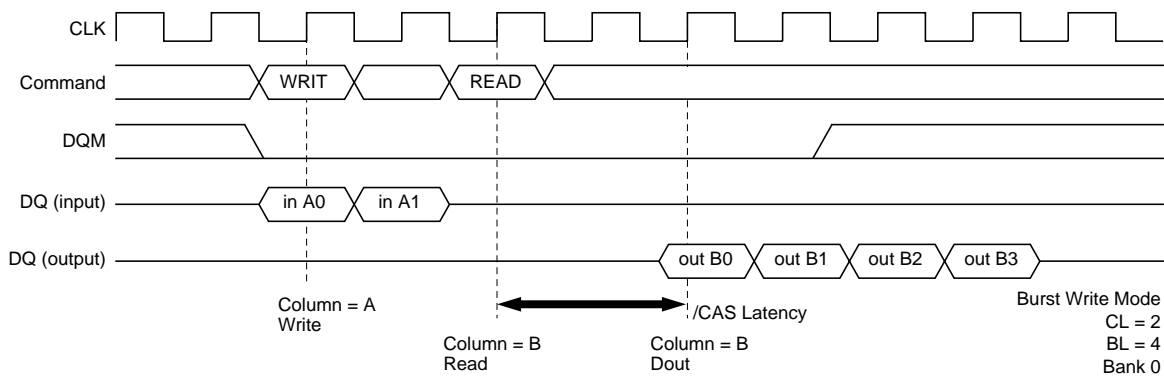

**WRITE to READ Command Interval (2)**

2. Same bank, different ROW address: When the ROW address changes, consecutive read commands cannot be executed; it is necessary to separate the two commands with a precharge command and a bank active command.
3. Different bank: When the bank changes, the read command can be performed after an interval of no less than 1 clock, provided that the other bank is in the bank active state. However, in the case of a burst write, data will continue to be written until one clock before the read command is executed (as in the case of the same bank and the same address).

**Read with auto precharge to Read command interval**

1. Different bank: When some banks are in the active state, the second read command (another bank) is executed. Even when the first read with auto-precharge is a burst read that is not yet finished, the data read by the second command is valid. The internal auto-precharge of one bank starts at the next clock of the second command.

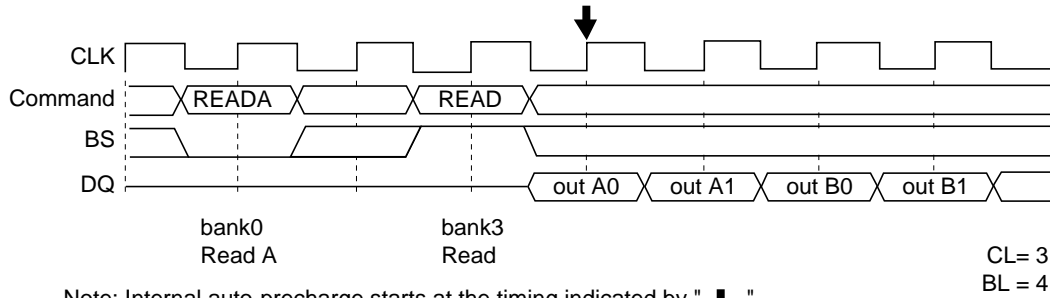

Note: Internal auto-precharge starts at the timing indicated by " ↓ ".

**Read with Auto Precharge to Read Command Interval (Different bank)**

2. Same bank: The consecutive read command (the same bank) is illegal.

**Write with auto precharge to Write command interval**

1. Different bank: When some banks are in the active state, the second write command (another bank) is executed. In the case of burst writes, the second write command has priority. The internal auto-precharge of one bank starts 2 clocks later from the second command.

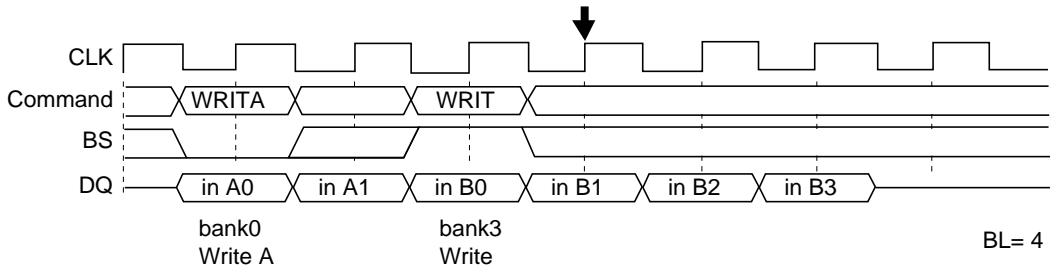

Note: Internal auto-precharge starts at the timing indicated by " ↓ ".

**Write with Auto Precharge to Write Command Interval (Different bank)**

2. Same bank: The consecutive write command (the same bank) is illegal.

**Read with auto precharge to Write command interval**

1. Different bank: When some banks are in the active state, the second write command (another bank) is executed. However, DQM must be set High so that the output buffer becomes High-Z before data input. The internal auto-precharge of one bank starts at the next clock of the second command.

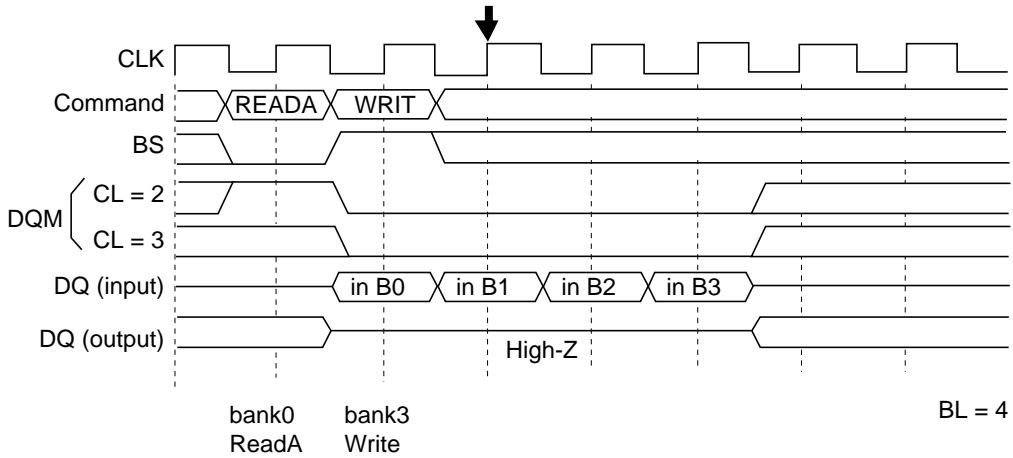

Note: Internal auto-precharge starts at the timing indicated by " ↓ ".

**Read with Auto Precharge to Write Command Interval (Different bank)**

2. Same bank: The consecutive write command from read with auto precharge (the same bank) is illegal. It is necessary to separate the two commands with a bank active command.

**Write with auto precharge to Read command interval**

1. Different bank: When some banks are in the active state, the second read command (another bank) is executed. However, in case of a burst write, data will continue to be written until one clock before the read command is executed. The internal auto-precharge of one bank starts at 2 clocks later from the second command.

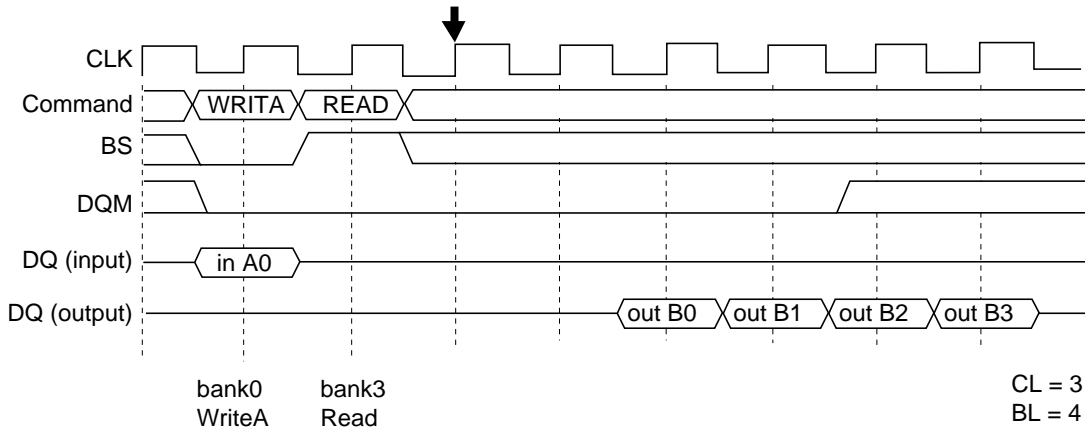

Note: Internal auto-precharge starts at the timing indicated by " ↓ ".

**Write with Auto Precharge to Read Command Interval (Different bank)**

2. Same bank: The consecutive read command from write with auto precharge (the same bank) is illegal. It is necessary to separate the two commands with a bank active command.

**Read command to Precharge command interval (same bank)**

When the precharge command is executed for the same bank as the read command that preceded it, the minimum interval between the two commands is one clock. However, since the output buffer then becomes High-Z after the clocks defined by IHZP, there is a case of interruption to burst read data output will be interrupted, if the precharge command is input during burst read. To read all data by burst read, the clocks defined by IEP must be assured as an interval from the final data output to precharge command execution.

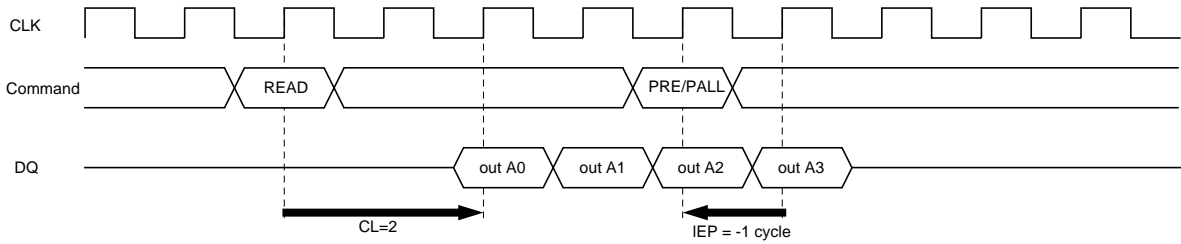

**READ to PRECHARGE Command Interval (same bank): To output all data (CL = 2, BL = 4)**

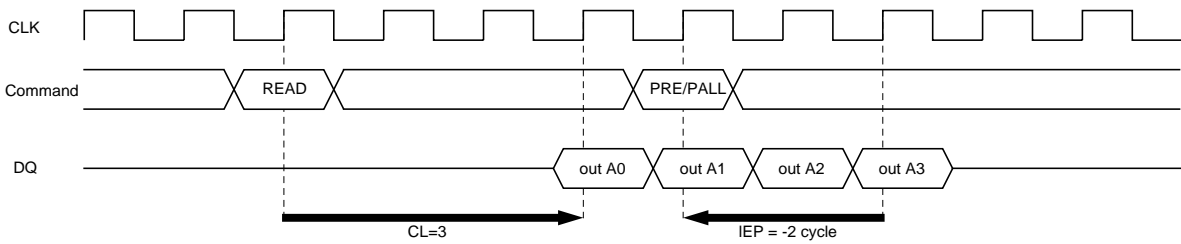

**READ to PRECHARGE Command Interval (same bank): To output all data (CL = 3, BL = 4)**

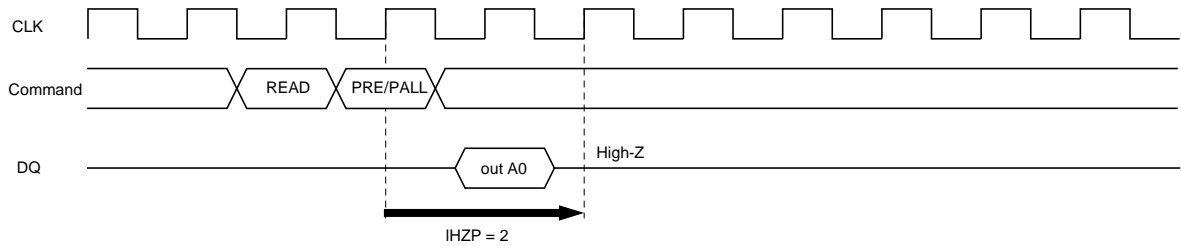

**READ to PRECHARGE Command Interval (same bank): To stop output data (CL = 2, BL = 1, 2, 4, 8)**

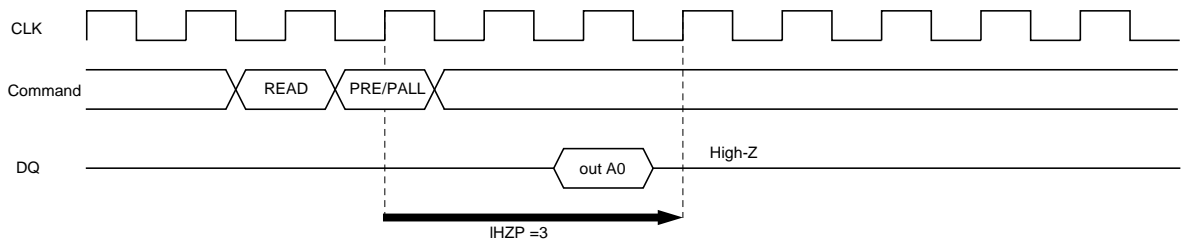

**READ to PRECHARGE Command Interval (same bank): To stop output data (CL = 3, BL = 1, 2, 4, 8)**

**Write command to Precharge command interval (same bank)**

When the precharge command is executed for the same bank as the write command that preceded it, the minimum interval between the two commands is 1 clock. However, if the burst write operation is unfinished, the input data must be masked by means of DQM for assurance of the clock defined by tDPL.

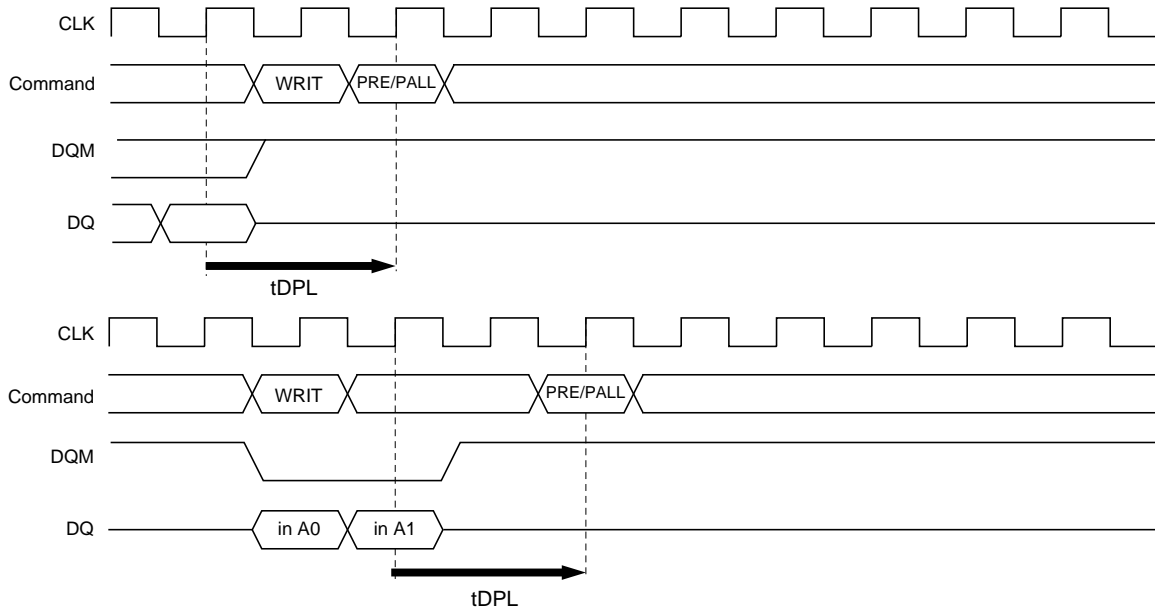

**WRITE to PRECHARGE Command Interval (same bank) (BL = 4 (To stop write operation))**

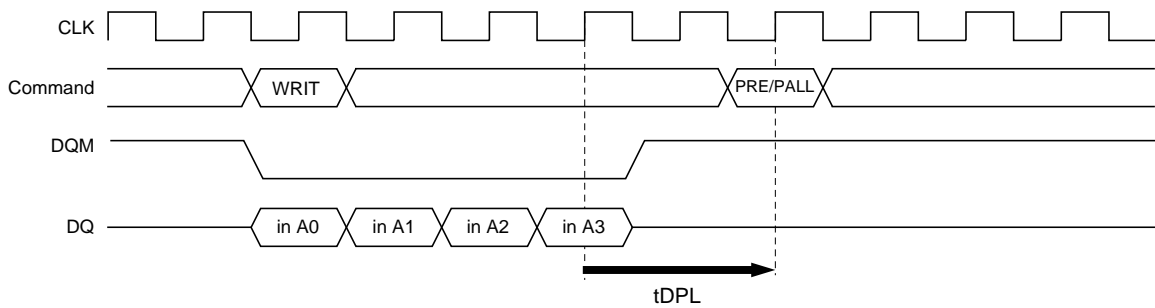

**WRITE to PRECHARGE Command Interval (same bank) (BL = 4 (To write all data))**

**Bank active command interval**

1. Same bank: The interval between the two bank active commands must be no less than  $t_{RC}$ .
2. In the case of different bank active commands: The interval between the two bank active commands must be no less than  $t_{RRD}$ .

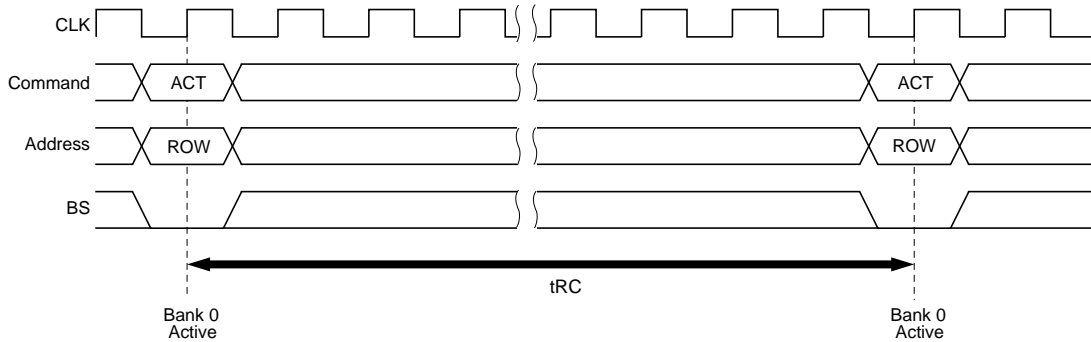

**Bank Active to Bank Active for Same Bank**

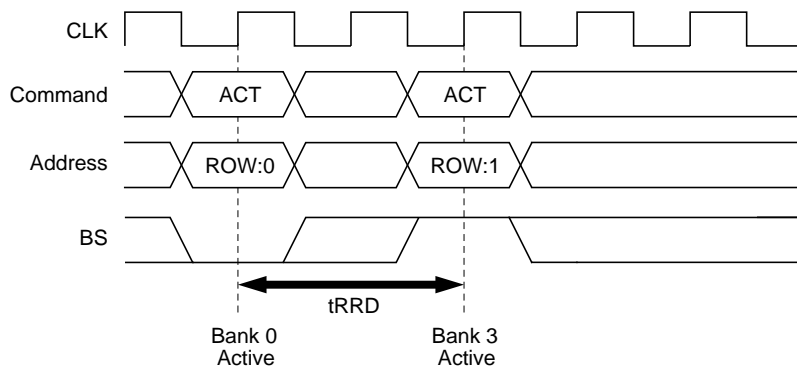

**Bank Active to Bank Active for Different Bank**

**Mode register set to Bank active command interval**

The interval between setting the mode register and executing a bank active command must be no less than  $t_{MRD}$ .

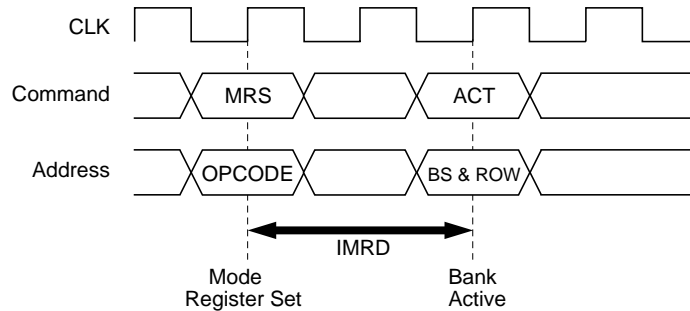

**Mode register set to Bank active command interval**

### DQM Control

The DQM mask the DQ data. The UDQM and LDQM mask the upper and lower bytes of the DQ data, respectively. The timing of UDQM/LDQM is different during reading and writing.

#### Reading

When data is read, the output buffer can be controlled by DQM. By setting DQM to Low, the output buffer becomes Low-Z, enabling data output. By setting DQM to High, the output buffer becomes High-Z, and the corresponding data is not output. However, internal reading operations continue. The latency of DQM during reading is 2 clocks.

#### Writing

Input data can be masked by DQM. By setting DQM to Low, data can be written. In addition, when DQM is set to High, the corresponding data is not written, and the previous data is held. The latency of DQM during writing is 0 clock.

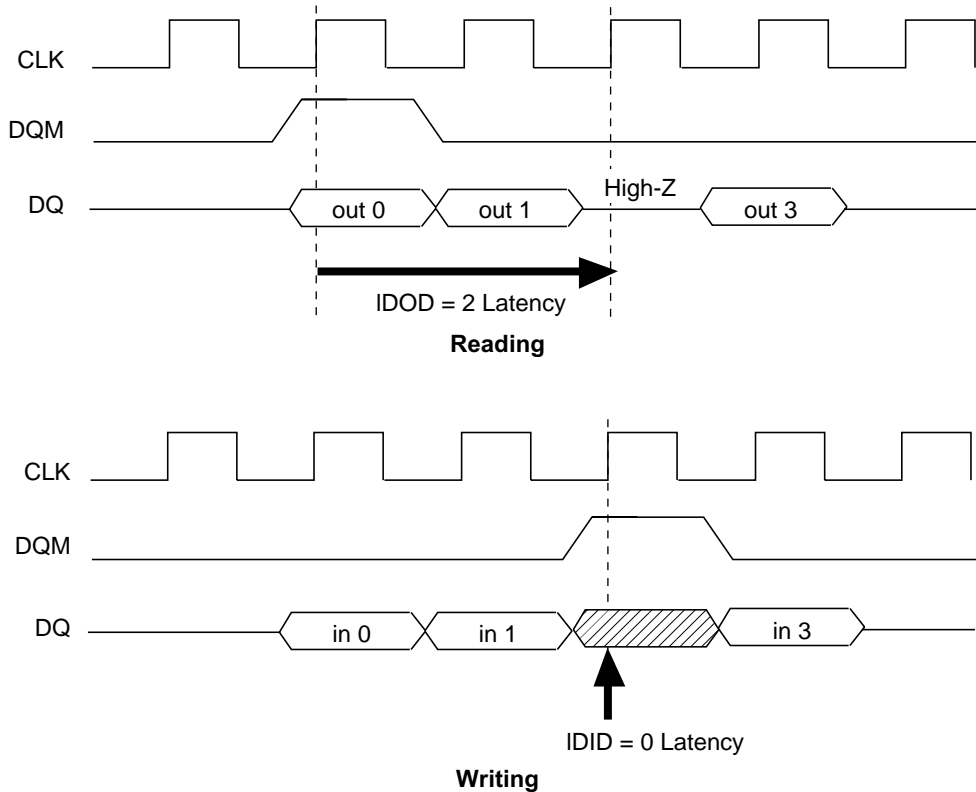

## Refresh

### Auto-refresh

All the banks must be precharged before executing an auto-refresh command. Since the auto-refresh command updates the internal counter every time it is executed and determines the banks and the ROW addresses to be refreshed, external address specification is not required. The refresh cycles are required to refresh all the ROW addresses within tREF (max.). The output buffer becomes High-Z after auto-refresh start. In addition, since a precharge has been completed by an internal operation after the auto-refresh, an additional precharge operation by the precharge command is not required.

### Self-refresh

After executing a self-refresh command, the self-refresh operation continues while CKE is held Low. During self-refresh operation, all ROW addresses are refreshed by the internal refresh timer. A self-refresh is terminated by a self-refresh exit command. Before and after self-refresh mode, execute auto-refresh to all refresh addresses in or within tREF (max.) period on the condition 1 and 2 below.

1. Enter self-refresh mode within time as below\* after either burst refresh or distributed refresh at equal interval to all refresh addresses are completed.
2. Start burst refresh or distributed refresh at equal interval to all refresh addresses within time as below\*after exiting from self-refresh mode.

Note: tREF (max.) / refresh cycles.

## Others

### Power-down mode

The SDRAM enters power-down mode when CKE goes Low in the IDLE state. In power down mode, power consumption is suppressed by deactivating the input initial circuit. Power down mode continues while CKE is held Low. In addition, by setting CKE to High, the SDRAM exits from the power down mode, and command input is enabled from the next clock. In this mode, internal refresh is not performed.

### Clock suspend mode

By driving CKE to Low during a bank active or read/write operation, the SDRAM enters clock suspend mode. During clock suspend mode, external input signals are ignored and the internal state is maintained. When CKE is driven High, the SDRAM terminates clock suspend mode, and command input is enabled from the next clock. For details, refer to the "CKE Truth Table".

Timing Waveforms

Read Cycle

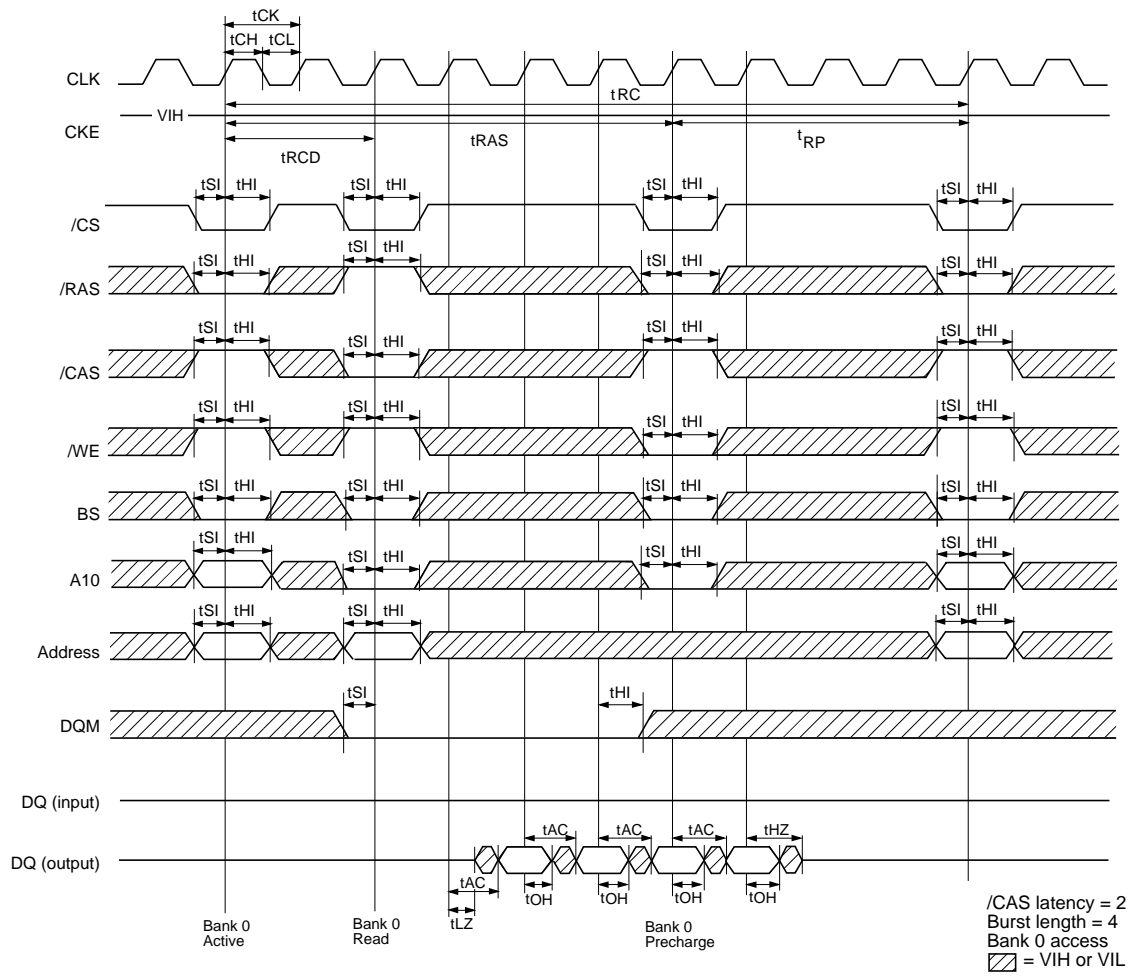

Write Cycle

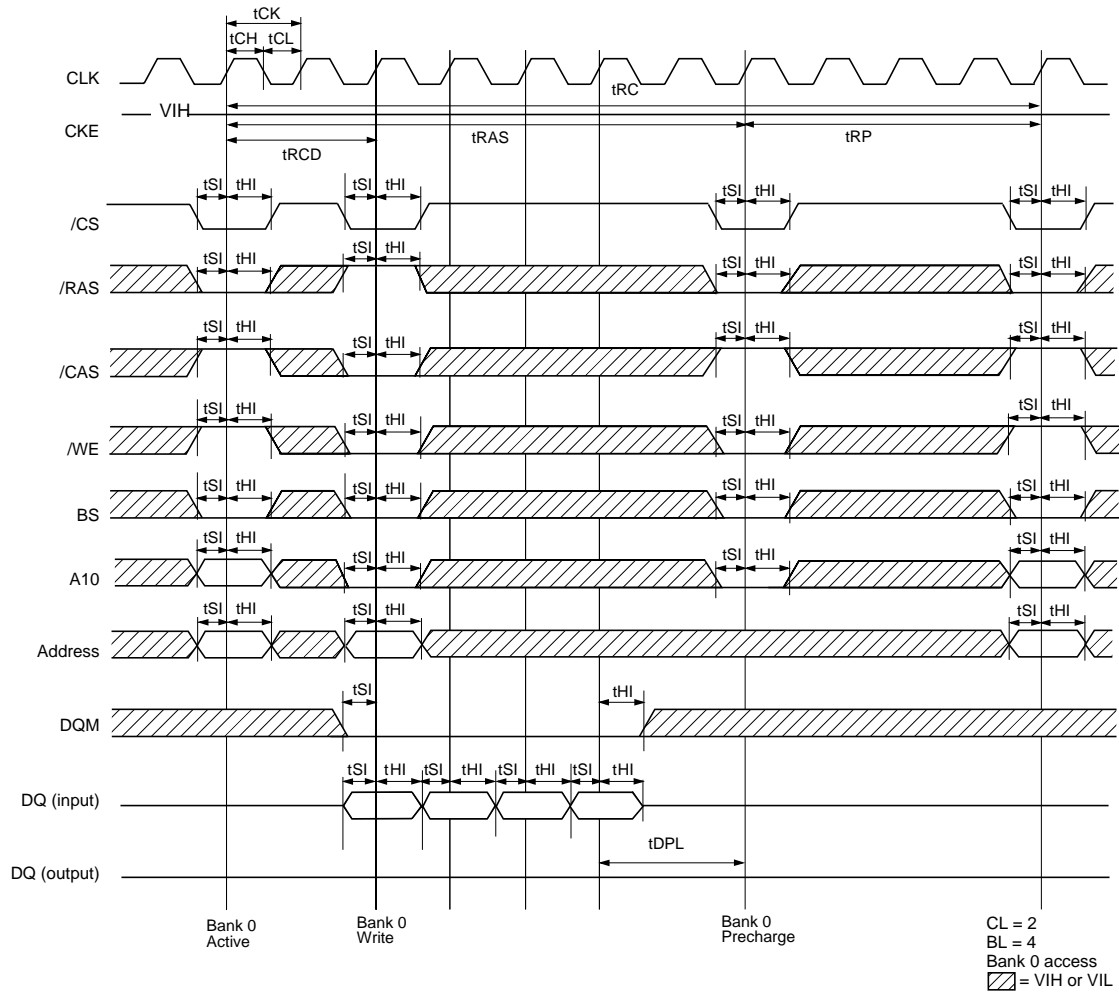

Mode Register Set Cycle

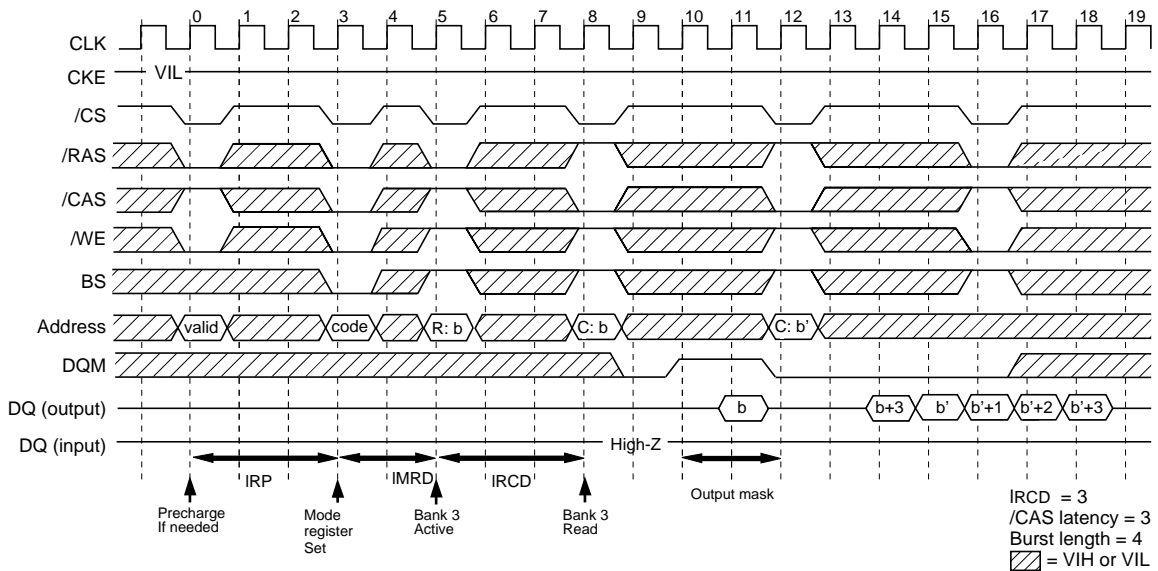

Read Cycle/Write Cycle

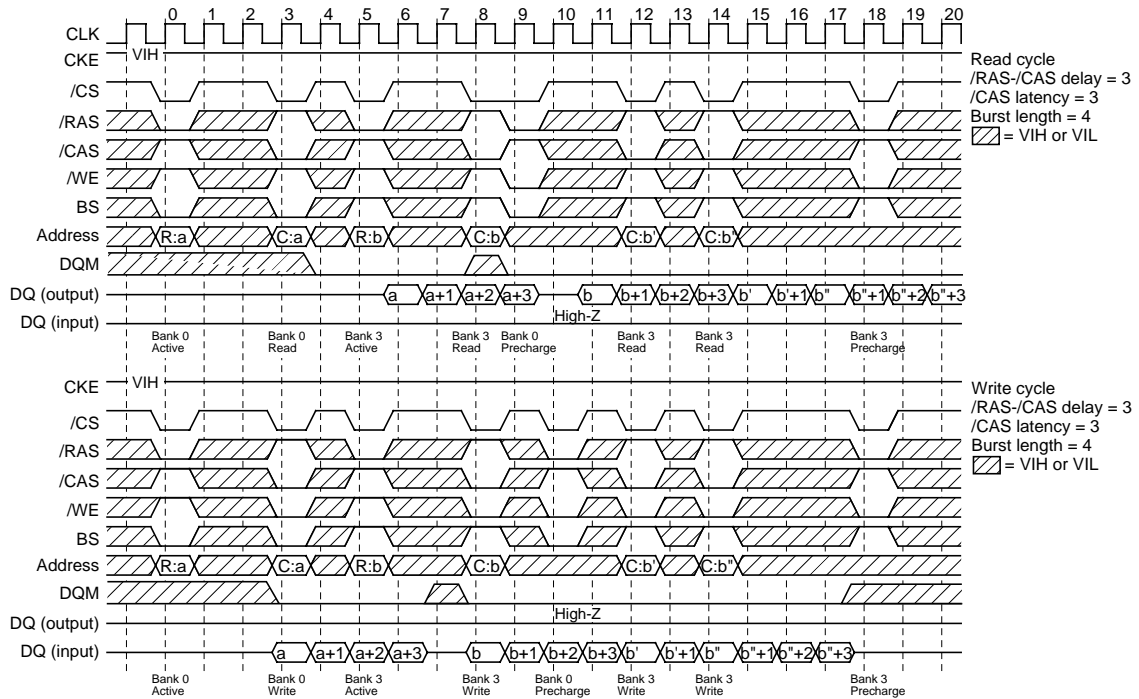

Read/Single Write Cycle

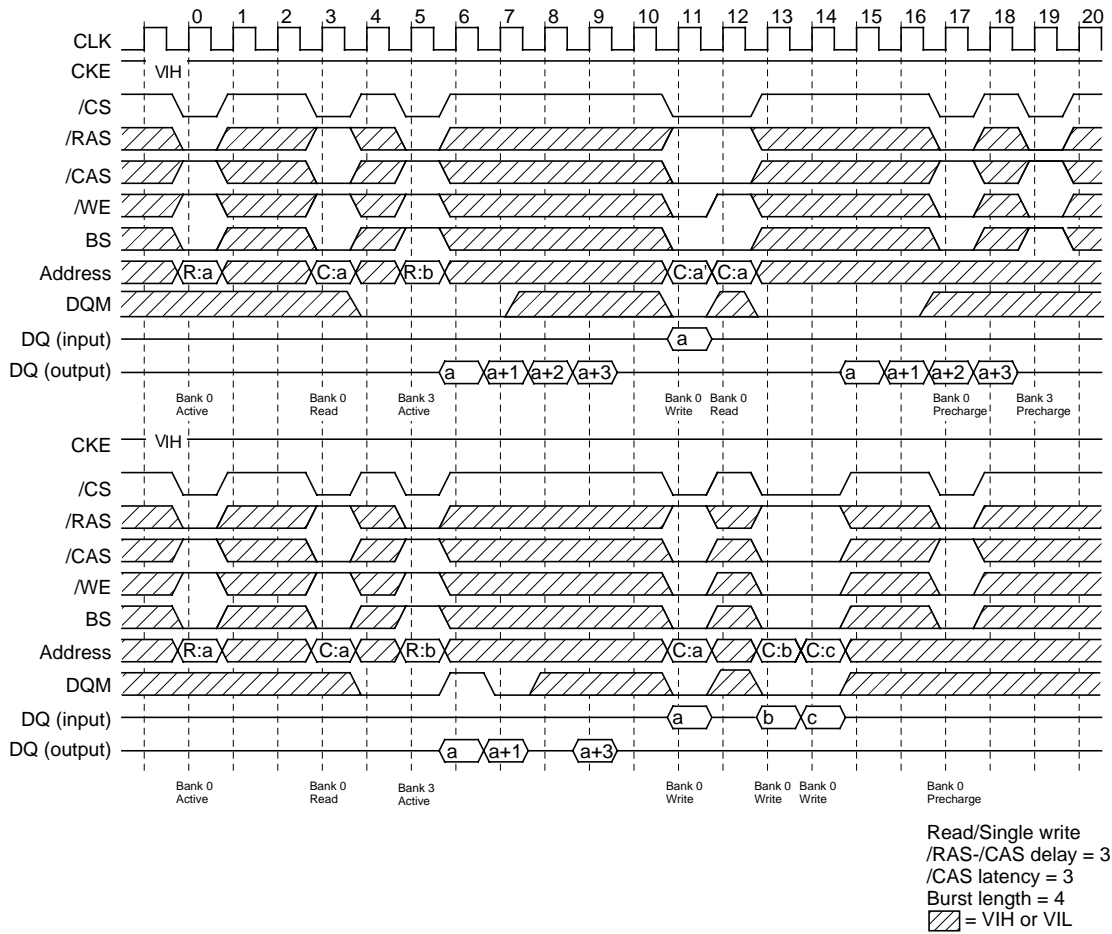

Read/Burst Write Cycle

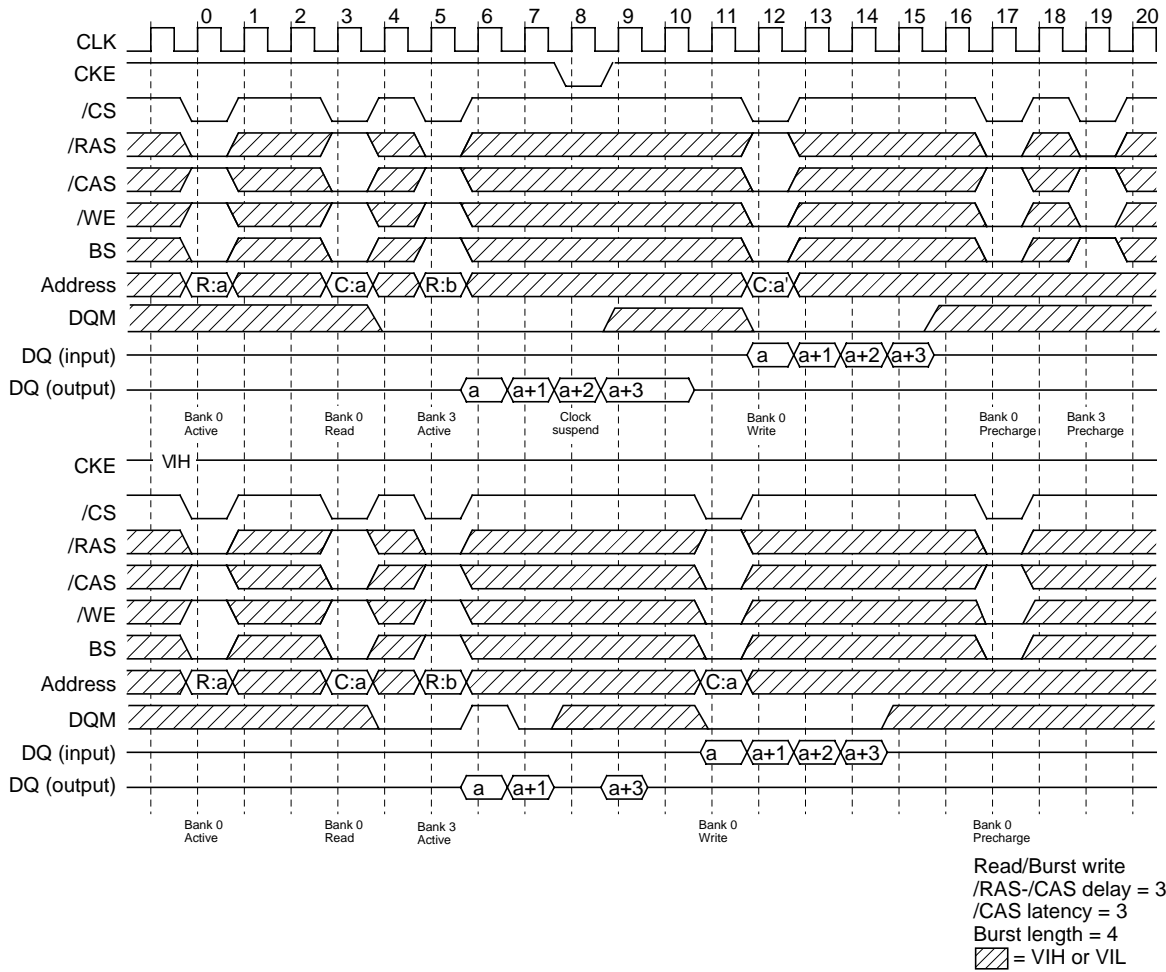

Auto Refresh Cycle

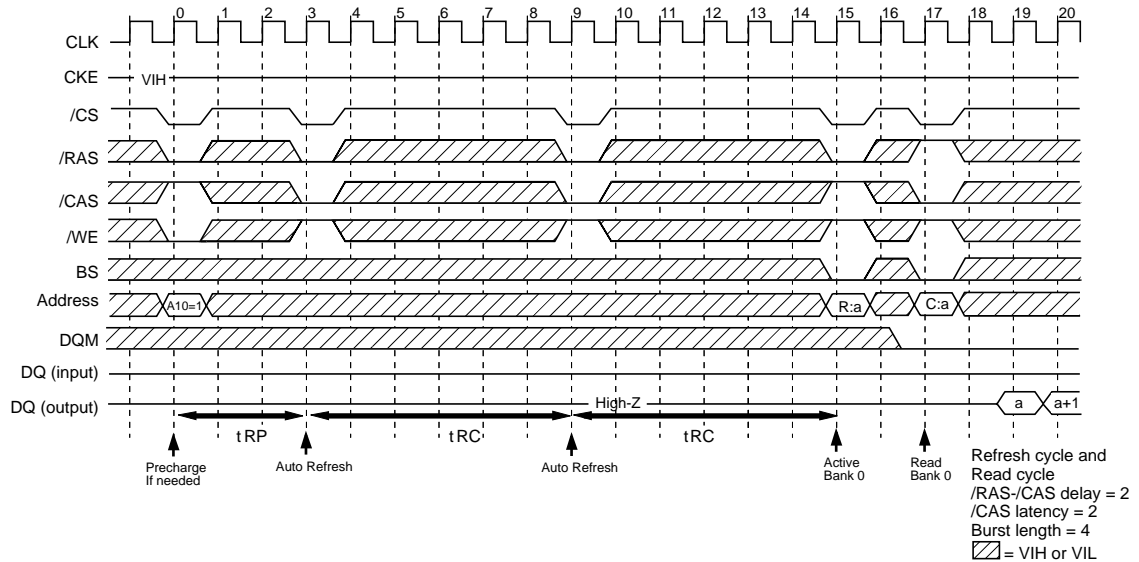

Self Refresh Cycle

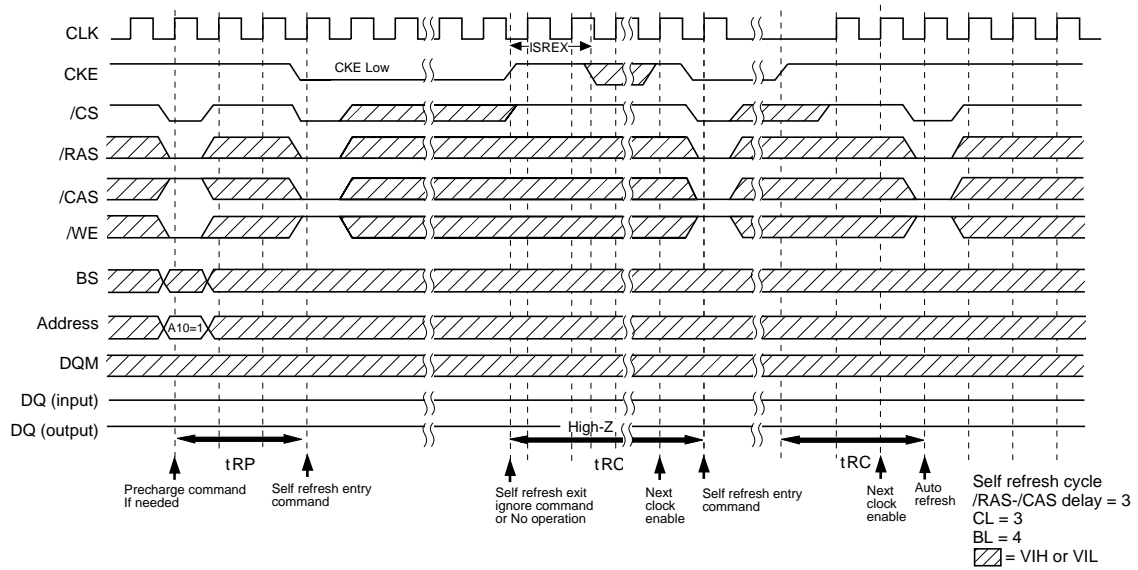

Clock Suspend Mode

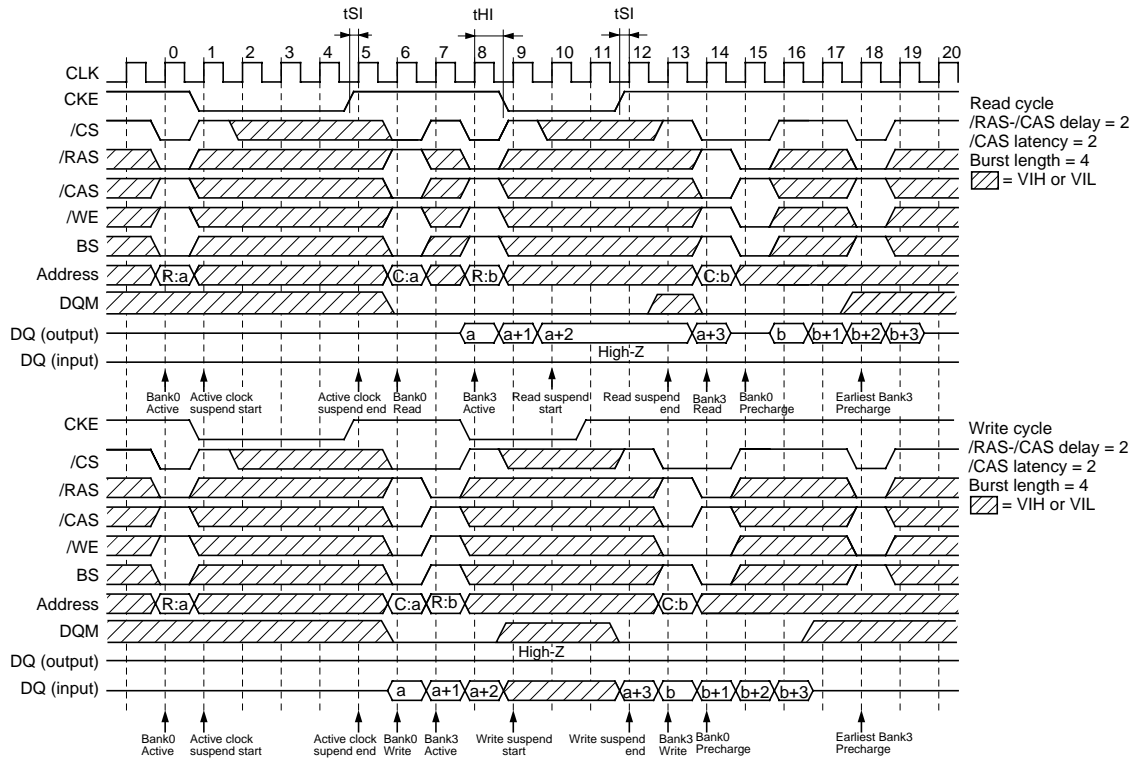

Power Down Mode

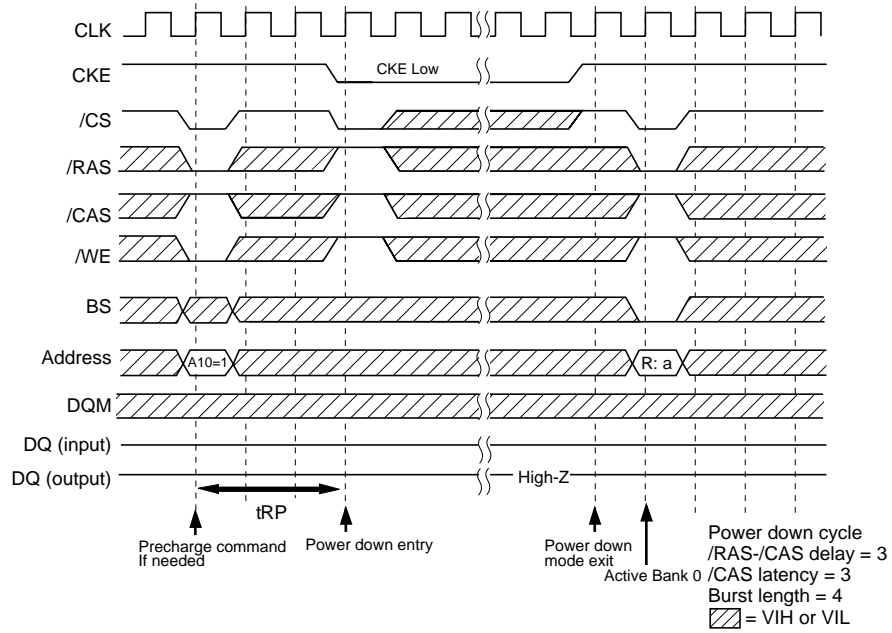

Initialization Sequence

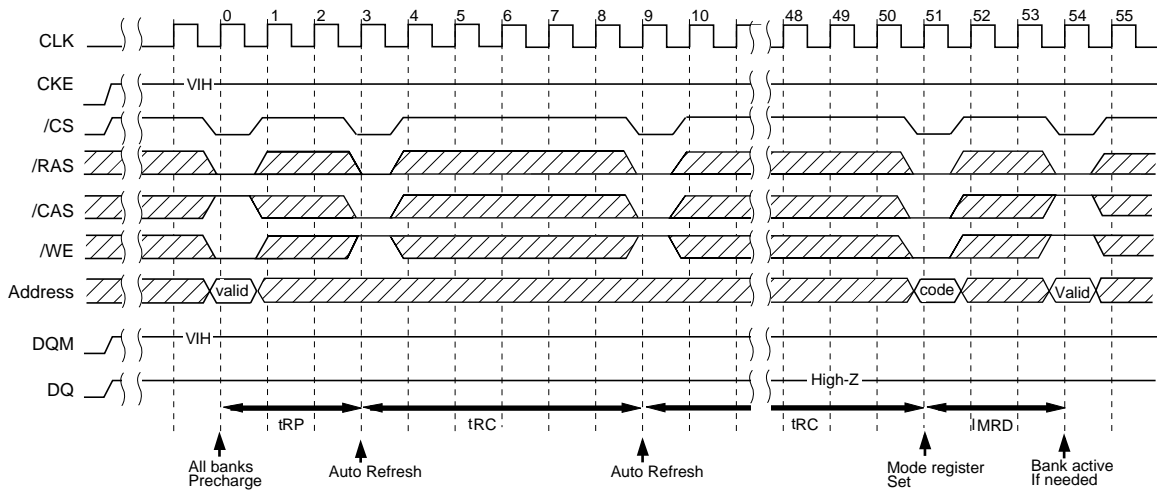

Package Drawing

Unit: mm

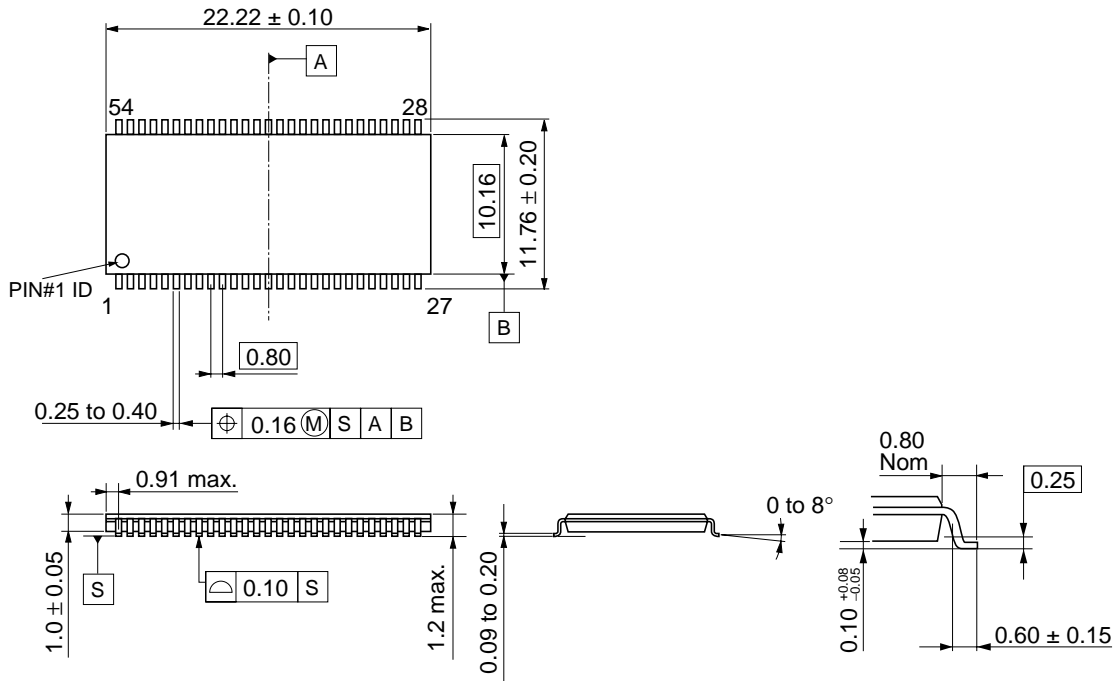

Note: Dimension "A" does not include mold flash, protrusions or gate burrs. Mold flash, protrusions or gate burrs shall not exceed 0.20mm per side.

ECA-TS2-0016-01

## **Recommended Soldering Conditions**

Please consult with our sales offices for soldering conditions of the EDS25XXAPTA.

## **Type of Surface Mount Device**

EDS25XXAPTA: 54-pin Plastic TSOP (II)

**NOTES FOR CMOS DEVICES****① PRECAUTION AGAINST ESD FOR MOS DEVICES**

Exposing the MOS devices to a strong electric field can cause destruction of the gate oxide and ultimately degrade the MOS devices operation. Steps must be taken to stop generation of static electricity as much as possible, and quickly dissipate it, when once it has occurred. Environmental control must be adequate. When it is dry, humidifier should be used. It is recommended to avoid using insulators that easily build static electricity. MOS devices must be stored and transported in an anti-static container, static shielding bag or conductive material. All test and measurement tools including work bench and floor should be grounded. The operator should be grounded using wrist strap. MOS devices must not be touched with bare hands. Similar precautions need to be taken for PW boards with semiconductor MOS devices on it.

**② HANDLING OF UNUSED INPUT PINS FOR CMOS DEVICES**

No connection for CMOS devices input pins can be a cause of malfunction. If no connection is provided to the input pins, it is possible that an internal input level may be generated due to noise, etc., hence causing malfunction. CMOS devices behave differently than Bipolar or NMOS devices. Input levels of CMOS devices must be fixed high or low by using a pull-up or pull-down circuitry. Each unused pin should be connected to  $V_{DD}$  or GND with a resistor, if it is considered to have a possibility of being an output pin. The unused pins must be handled in accordance with the related specifications.

**③ STATUS BEFORE INITIALIZATION OF MOS DEVICES**

Power-on does not necessarily define initial status of MOS devices. Production process of MOS does not define the initial operation status of the device. Immediately after the power source is turned ON, the MOS devices with reset function have not yet been initialized. Hence, power-on does not guarantee output pin levels, I/O settings or contents of registers. MOS devices are not initialized until the reset signal is received. Reset operation must be executed immediately after power-on for MOS devices having reset function.

CME0107

The information in this document is subject to change without notice. Before using this document, confirm that this is the latest version.

No part of this document may be copied or reproduced in any form or by any means without the prior written consent of Elpida Memory, Inc.

Elpida Memory, Inc. does not assume any liability for infringement of any intellectual property rights (including but not limited to patents, copyrights, and circuit layout licenses) of Elpida Memory, Inc. or third parties by or arising from the use of the products or information listed in this document. No license, express, implied or otherwise, is granted under any patents, copyrights or other intellectual property rights of Elpida Memory, Inc. or others.

Descriptions of circuits, software and other related information in this document are provided for illustrative purposes in semiconductor product operation and application examples. The incorporation of these circuits, software and information in the design of the customer's equipment shall be done under the full responsibility of the customer. Elpida Memory, Inc. assumes no responsibility for any losses incurred by customers or third parties arising from the use of these circuits, software and information.

**[Product applications]**

Elpida Memory, Inc. makes every attempt to ensure that its products are of high quality and reliability. However, users are instructed to contact Elpida Memory's sales office before using the product in aerospace, aeronautics, nuclear power, combustion control, transportation, traffic, safety equipment, medical equipment for life support, or other such application in which especially high quality and reliability is demanded or where its failure or malfunction may directly threaten human life or cause risk of bodily injury.

**[Product usage]**

Design your application so that the product is used within the ranges and conditions guaranteed by Elpida Memory, Inc., including the maximum ratings, operating supply voltage range, heat radiation characteristics, installation conditions and other related characteristics. Elpida Memory, Inc. bears no responsibility for failure or damage when the product is used beyond the guaranteed ranges and conditions. Even within the guaranteed ranges and conditions, consider normally foreseeable failure rates or failure modes in semiconductor devices and employ systemic measures such as fail-safes, so that the equipment incorporating Elpida Memory, Inc. products does not cause bodily injury, fire or other consequential damage due to the operation of the Elpida Memory, Inc. product.

**[Usage environment]**

This product is not designed to be resistant to electromagnetic waves or radiation. This product must be used in a non-condensing environment.

If you export the products or technology described in this document that are controlled by the Foreign Exchange and Foreign Trade Law of Japan, you must follow the necessary procedures in accordance with the relevant laws and regulations of Japan. Also, if you export products/technology controlled by U.S. export control regulations, or another country's export control laws or regulations, you must follow the necessary procedures in accordance with such laws or regulations.

If these products/technology are sold, leased, or transferred to a third party, or a third party is granted license to use these products, that third party must be made aware that they are responsible for compliance with the relevant laws and regulations.

M01E0107