

# CS8190

## Precision Air-Core Tach/Speedo Driver with Return to Zero

The CS8190 is specifically designed for use with air-core meter movements. The IC provides all the functions necessary for an analog tachometer or speedometer. The CS8190 takes a speed sensor input and generates sine and cosine related output signals to differentially drive an air-core meter.

Many enhancements have been added over industry standard tachometer drivers such as the CS289 or LM1819. The output utilizes differential drivers which eliminates the need for a zener reference and offers more torque. The device withstands 60 V transients which decreases the protection circuitry required. The device is also more precise than existing devices allowing for fewer trims and for use in a speedometer.

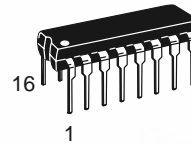
### Features

- Direct Sensor Input
- High Output Torque
- Low Pointer Flutter
- High Input Impedance
- Overvoltage Protection
- Return to Zero
- Internally Fused Leads in DIP-16 and SO-20L Packages

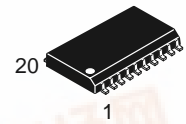


ON Semiconductor™

<http://onsemi.com>

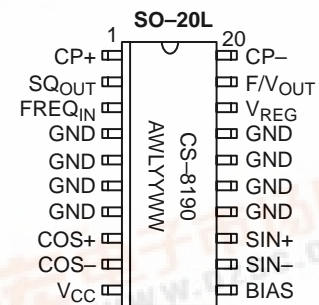
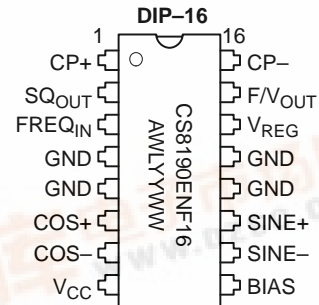


DIP-16  
NF SUFFIX  
CASE 648



SO-20L  
DWF SUFFIX  
CASE 751D

### PIN CONNECTIONS AND MARKING DIAGRAM



A = Assembly Location  
WL, L = Wafer Lot  
YY, Y = Year  
WW, W = Work Week

### ORDERING INFORMATION

Device	Package	Shipping
CS8190ENF16	DIP-16	25 Units/Rail
CS8190EDWF20	SO-20L	37 Units/Rail
CS8190EDWFR20	SO-20L	1000 Tape & Reel



# CS8190

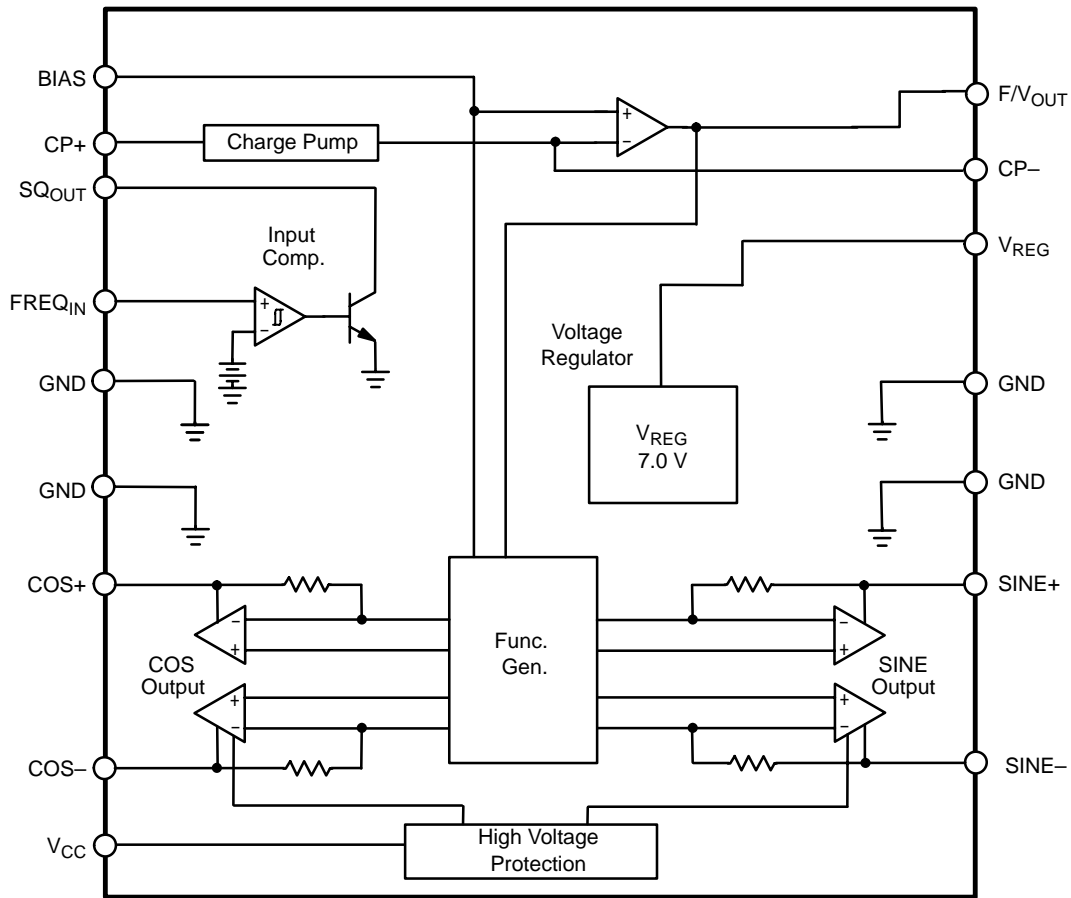


Figure 1. Block Diagram

## ABSOLUTE MAXIMUM RATINGS\*

Rating	Value	Unit	
Supply Voltage, V <sub>CC</sub>	< 100 ms Pulse Transient	60	V
	Continuous	24	V
Operating Temperature	-40 to +105	°C	
Storage Temperature	-40 to +165	°C	
Junction Temperature	-40 to +150	°C	
ESD (Human Body Model)	4.0	kV	
Lead Temperature Soldering:	Wave Solder (through hole styles only) (Note 1.)	260 peak	°C
	Reflow: (SMD styles only) (Note 2.)	230 peak	°C

1. 10 seconds maximum.

2. 60 second maximum above 183°C.

\*The maximum package power dissipation must be observed.

# CS8190

## ELECTRICAL CHARACTERISTICS ( $-40^{\circ}\text{C} \leq T_A \leq 85^{\circ}\text{C}$ , $8.5\text{ V} \leq V_{CC} \leq 15\text{ V}$ , unless otherwise specified.)

Characteristic	Test Conditions	Min	Typ	Max	Unit
<b>Supply Voltage Section</b>					
$I_{CC}$ Supply Current	$V_{CC} = 16\text{ V}$ , $-40^{\circ}\text{C}$ , No Load	–	50	125	mA
$V_{CC}$ Normal Operation Range	–	8.5	13.1	16	V

<b>Input Comparator Section</b>					
Positive Input Threshold	–	1.0	2.0	3.0	V
Input Hysteresis	–	200	500	–	mV
Input Bias Current (Note 3.)	$0\text{ V} \leq V_{IN} \leq 8.0\text{ V}$	–	–10	–80	$\mu\text{A}$
Input Frequency Range	–	0	–	20	kHz
Input Voltage Range	in series with $1.0\text{ k}\Omega$	–1.0	–	$V_{CC}$	V
Output $V_{SAT}$	$I_{CC} = 10\text{ mA}$	–	0.15	0.40	V
Output Leakage	$V_{CC} = 7.0\text{ V}$	–	–	10	$\mu\text{A}$
Low $V_{CC}$ Disable Threshold	–	7.0	8.0	8.5	V
Logic 0 Input Voltage	–	1.0	–	–	V

<b>Voltage Regulator Section</b>					
Output Voltage	–	6.25	7.00	7.50	V
Output Load Current	–	–	–	10	mA
Output Load Regulation	0 to 10 mA	–	10	50	mV
Output Line Regulation	$8.5\text{ V} \leq V_{CC} \leq 16\text{ V}$	–	20	150	mV
Power Supply Rejection	$V_{CC} = 13.1\text{ V}$ , $1.0\text{ V}_{P/P}$ $1.0\text{ kHz}$	34	46	–	dB

<b>Charge Pump Section</b>					
Inverting Input Voltage	–	1.5	2.0	2.5	V
Input Bias Current	–	–	40	150	nA
$V_{BIAS}$ Input Voltage	–	1.5	2.0	2.5	V
Non Invert. Input Voltage	$I_{IN} = 1.0\text{ mA}$	–	0.7	1.1	V
Linearity (Note 4.)	@ 0, 87.5, 175, 262.5, + 350 Hz	–0.10	0.28	+0.70	%
F/ $V_{OUT}$ Gain	@ 350 Hz, $C_{CP} = 0.0033\text{ }\mu\text{F}$ , $R_T = 243\text{ k}\Omega$	7.0	10	13	mV/Hz
Norton Gain, Positive	$I_{IN} = 15\text{ }\mu\text{A}$	0.9	1.0	1.1	I/I
Norton Gain, Negative	$I_{IN} = 15\text{ }\mu\text{A}$	0.9	1.0	1.1	I/I

### Function Generator Section: $-40^{\circ}\text{C} \leq T_A \leq 85^{\circ}\text{C}$ , $V_{CC} = 13.1\text{ V}$ unless otherwise noted.

Return to Zero Threshold	$T_A = 25^{\circ}\text{C}$	5.2	6.0	7.0	V
Differential Drive Voltage ( $V_{COS+} - V_{COS-}$ )	$8.5\text{ V} \leq V_{CC} \leq 16\text{ V}$ $\Theta = 0^{\circ}$	5.5	6.5	7.5	V
Differential Drive Voltage ( $V_{SIN+} - V_{SIN-}$ )	$8.5\text{ V} \leq V_{CC} \leq 16\text{ V}$ $\Theta = 90^{\circ}$	5.5	6.5	7.5	V
Differential Drive Voltage ( $V_{COS+} - V_{COS-}$ )	$8.5\text{ V} \leq V_{CC} \leq 16\text{ V}$ $\Theta = 180^{\circ}$	–7.5	–6.5	–5.5	V
Differential Drive Voltage ( $V_{SIN+} - V_{SIN-}$ )	$8.5\text{ V} \leq V_{CC} \leq 16\text{ V}$ $\Theta = 270^{\circ}$	–7.5	–6.5	–5.5	V

3. Input is clamped by an internal 12 V Zener.

4. Applies to % of full scale ( $270^{\circ}$ ).

## CS8190

### ELECTRICAL CHARACTERISTICS (continued) ( $-40^{\circ}\text{C} \leq T_A \leq 85^{\circ}\text{C}$ , $8.5\text{ V} \leq V_{CC} \leq 15\text{ V}$ , unless otherwise specified.)

Characteristic	Test Conditions	Min	Typ	Max	Unit
<b>Function Generator Section: <math>-40^{\circ}\text{C} \leq T_A \leq 85^{\circ}\text{C}</math>, <math>V_{CC} = 13.1\text{ V}</math> unless otherwise noted. (continued)</b>					
Differential Drive Current	$8.5\text{ V} \leq V_{CC} \leq 16\text{ V}$	–	33	42	mA
Zero Hertz Output Angle	–	–1.5	0	1.5	deg
Function Generator Error (Note 5.) Reference Figures 2, 3, 4, 5	$V_{CC} = 13.1\text{ V}$ $\Theta = 0^{\circ}$ to $305^{\circ}$	–2.0	0	+2.0	deg
Function Generator Error	$13.1\text{ V} \leq V_{CC} \leq 16\text{ V}$	–2.5	0	+2.5	deg
Function Generator Error	$13.1\text{ V} \leq V_{CC} \leq 11\text{ V}$	–1.0	0	+1.0	deg
Function Generator Error	$13.1\text{ V} \leq V_{CC} \leq 9.0\text{ V}$	–3.0	0	+3.0	deg
Function Generator Error	$25^{\circ}\text{C} \leq T_A \leq 80^{\circ}\text{C}$	–3.0	0	+3.0	deg
Function Generator Error	$25^{\circ}\text{C} \leq T_A \leq 105^{\circ}\text{C}$	–5.5	0	+5.5	deg
Function Generator Error	$-40^{\circ}\text{C} \leq T_A \leq 25^{\circ}\text{C}$	–3.0	0	+3.0	deg
Function Generator Gain	$T_A = 25^{\circ}\text{C}$ , $\Theta$ vs $F/V_{OUT}$	60	77	95	$^{\circ}/\text{V}$

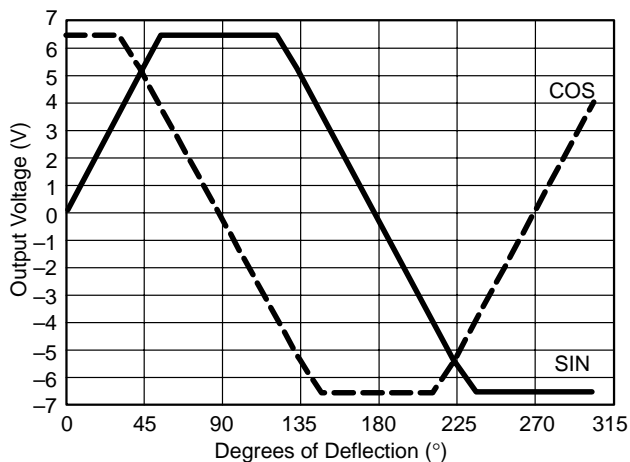
5. Deviation from nominal per Table 1 after calibration at  $0^{\circ}$  and  $270^{\circ}$ .

### PIN FUNCTION DESCRIPTION

PACKAGE PIN #		PIN SYMBOL	FUNCTION
DIP-16	SO-20L		
1	1	CP+	Positive input to charge pump.
2	2	SQ <sub>OUT</sub>	Buffered square wave output signal.
3	3	FREQ <sub>IN</sub>	Speed or RPM input signal.
4, 5, 12, 13	4-7, 14-17	GND	Ground Connections.
6	8	COS+	Positive cosine output signal.
7	9	COS-	Negative cosine output signal.
8	10	V <sub>CC</sub>	Ignition or battery supply voltage.
9	11	BIAS	Test point or zero adjustment.
10	12	SIN-	Negative sine output signal.
11	13	SIN+	Positive sine output signal.
14	18	V <sub>REG</sub>	Voltage regulator output.
15	19	F/V <sub>OUT</sub>	Output voltage proportional to input signal frequency.
16	20	CP-	Negative input to charge pump.

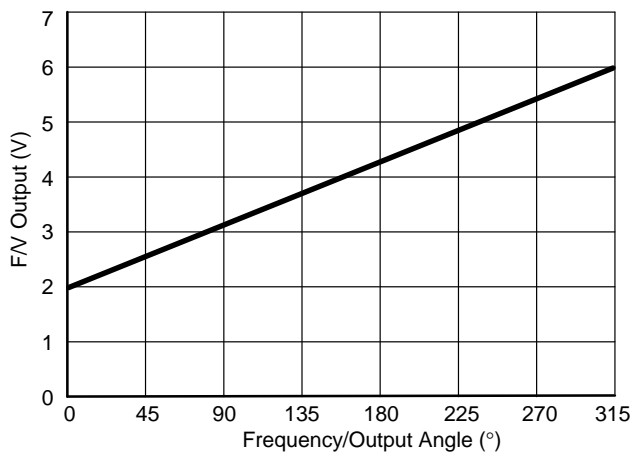
# CS8190

## TYPICAL PERFORMANCE CHARACTERISTICS

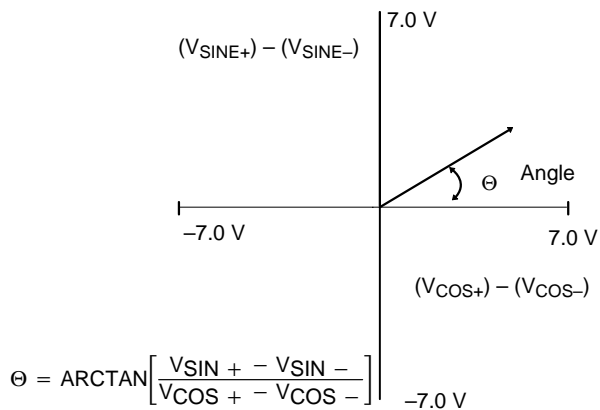


**Figure 2. Function Generator Output Voltage vs. Degrees of Deflection**

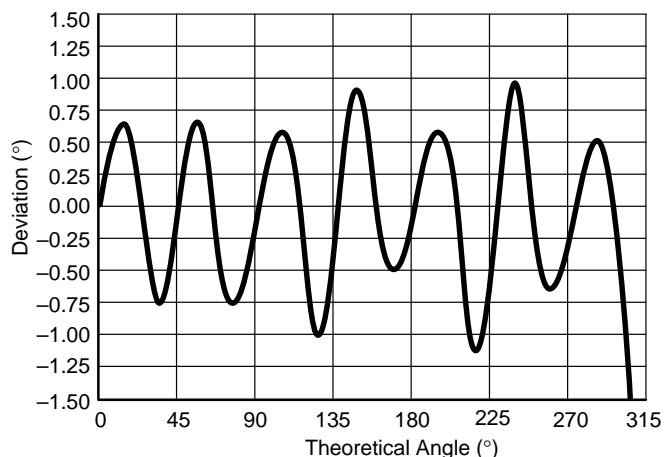
$$F/V_{OUT} = 2.0 V + 2.0 \times \text{FREQ} \times C_{CP} \times R_T \times (V_{REG} - 0.7 V)$$



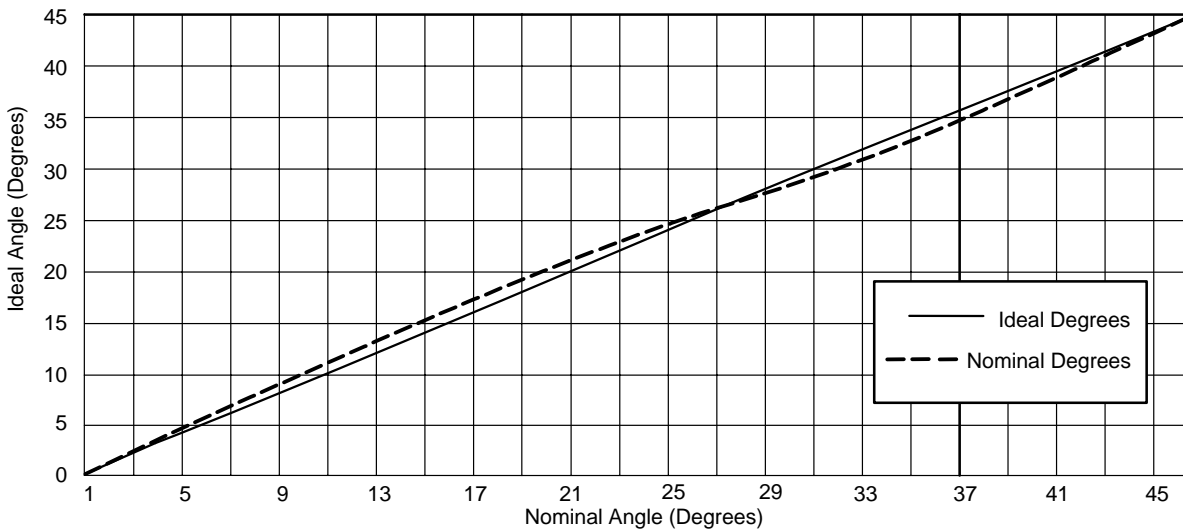
**Figure 3. Charge Pump Output Voltage vs. Output Angle**



**Figure 4. Output Angle in Polar Form**



**Figure 5. Nominal Output Deviation**



**Figure 6. Nominal Angle vs. Ideal Angle (After Calibrating at 180°)**

## CS8190

**Table 1. Function Generator Output Nominal Angle vs. Ideal Angle (After Calibrating at 270°)**

Ideal $\Theta$ Degrees	Nominal $\Theta$ Degrees	Ideal $\Theta$ Degrees	Nominal $\Theta$ Degrees	Ideal $\Theta$ Degrees	Nominal $\Theta$ Degrees	Ideal $\Theta$ Degrees	Nominal $\Theta$ Degrees	Ideal $\Theta$ Degrees	Nominal $\Theta$ Degrees	Ideal $\Theta$ Degrees	Nominal $\Theta$ Degrees
0	0	17	17.98	34	33.04	75	74.00	160	159.14	245	244.63
1	1.09	18	18.96	35	34.00	80	79.16	165	164.00	250	249.14
2	2.19	19	19.92	36	35.00	85	84.53	170	169.16	255	254.00
3	3.29	20	20.86	37	36.04	90	90.00	175	174.33	260	259.16
4	4.38	21	21.79	38	37.11	95	95.47	180	180.00	265	264.53
5	5.47	22	22.71	39	38.21	100	100.84	185	185.47	270	270.00
6	6.56	23	23.61	40	39.32	105	106.00	190	190.84	275	275.47
7	7.64	24	24.50	41	40.45	110	110.86	195	196.00	280	280.84
8	8.72	25	25.37	42	41.59	115	115.37	200	200.86	285	286.00
9	9.78	26	26.23	43	42.73	120	119.56	205	205.37	290	290.86
10	10.84	27	27.07	44	43.88	125	124.00	210	209.56	295	295.37
11	11.90	28	27.79	45	45.00	130	129.32	215	214.00	300	299.21
12	12.94	29	28.73	50	50.68	135	135.00	220	219.32	305	303.02
13	13.97	30	29.56	55	56.00	140	140.68	225	225.00		
14	14.99	31	30.39	60	60.44	145	146.00	230	230.58		
15	16.00	32	31.24	65	64.63	150	150.44	235	236.00		
16	17.00	33	32.12	70	69.14	155	154.63	240	240.44		

Note: Temperature, voltage and nonlinearity not included.

### CIRCUIT DESCRIPTION and APPLICATION NOTES

The CS8190 is specifically designed for use with air-core meter movements. It includes an input comparator for sensing an input signal from an ignition pulse or speed sensor, a charge pump for frequency to voltage conversion, a bandgap voltage regulator for stable operation, and a function generator with sine and cosine amplifiers to differentially drive the meter coils.

From the partial schematic of Figure 7, the input signal is applied to the  $FREQ_{IN}$  lead, this is the input to a high impedance comparator with a typical positive input threshold of 2.0 V and typical hysteresis of 0.5 V. The output of the comparator,  $SQ_{OUT}$ , is applied to the charge pump input  $CP+$  through an external capacitor  $C_{CP}$ . When the input signal changes state,  $C_{CP}$  is charged or discharged through  $R3$  and  $R4$ . The charge accumulated on  $C_{CP}$  is mirrored to  $C4$  by the Norton Amplifier circuit comprising of  $Q1$ ,  $Q2$  and  $Q3$ . The charge pump output voltage,  $F/V_{OUT}$ , ranges from 2.0 V to 6.3 V depending on the input signal frequency and the gain of the charge pump according to the formula:

$$F/V_{OUT} = 2.0 V + 2.0 \times FREQ \times C_{CP} \times R_T \times (V_{REG} - 0.7 V)$$

$R_T$  is a potentiometer used to adjust the gain of the F/V output stage and give the correct meter deflection. The F/V output voltage is applied to the function generator which generates the sine and cosine output voltages. The output voltage of the sine and cosine amplifiers are derived from the

on-chip amplifier and function generator circuitry. The various trip points for the circuit (i.e., 0°, 90°, 180°, 270°) are determined by an internal resistor divider and the bandgap voltage reference. The coils are differentially driven, allowing bidirectional current flow in the outputs, thus providing up to 305° range of meter deflection. Driving the coils differentially offers faster response time, higher current capability, higher output voltage swings, and reduced external component count. The key advantage is a higher torque output for the pointer.

The output angle,  $\Theta$ , is equal to the F/V gain multiplied by the function generator gain:

$$\Theta = AF/V \times AFG,$$

where:

$$AFG = 77^\circ/V(\text{typ})$$

The relationship between input frequency and output angle is:

$$\Theta = AFG \times 2.0 \times FREQ \times C_{CP} \times R_T \times (V_{REG} - 0.7 V)$$

$$\text{or, } \Theta = 970 \times FREQ \times C_{CP} \times R_T$$

The ripple voltage at the F/V converter's output is determined by the ratio of  $C_{CP}$  and  $C4$  in the formula:

$$\Delta V = \frac{C_{CP}(V_{REG} - 0.7 V)}{C4}$$

## CS8190

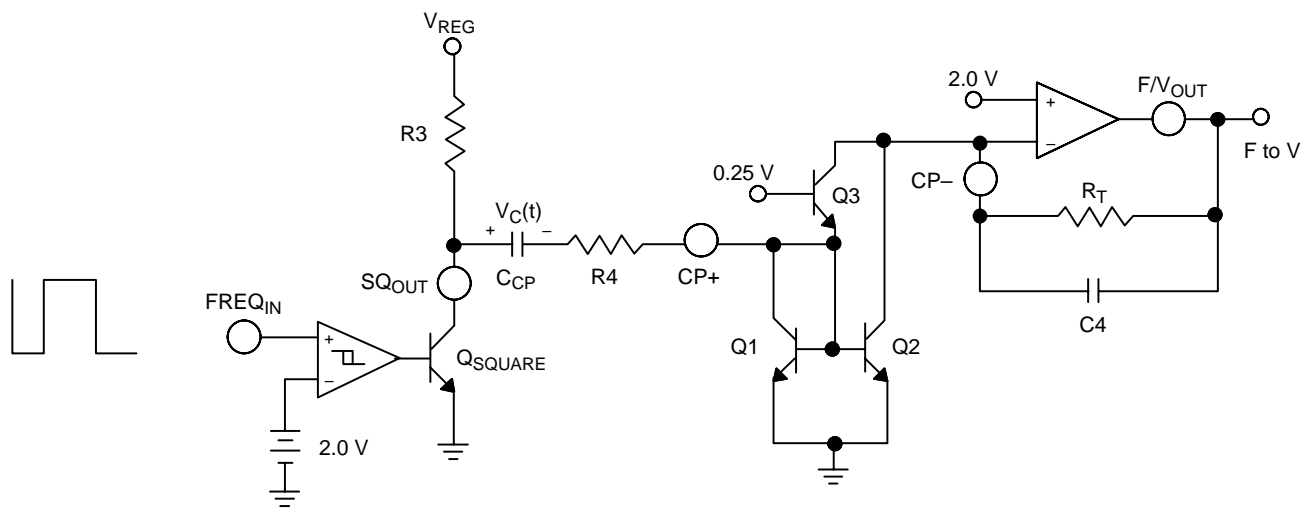


Figure 7. Partial Schematic of Input and Charge Pump

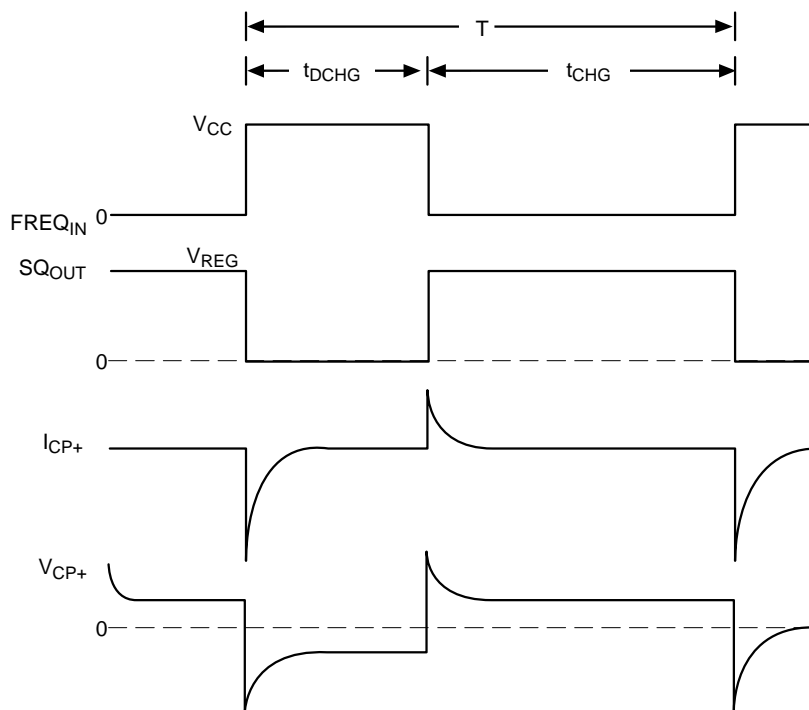


Figure 8. Timing Diagram of  $FREQ_{IN}$  and  $I_{CP}$

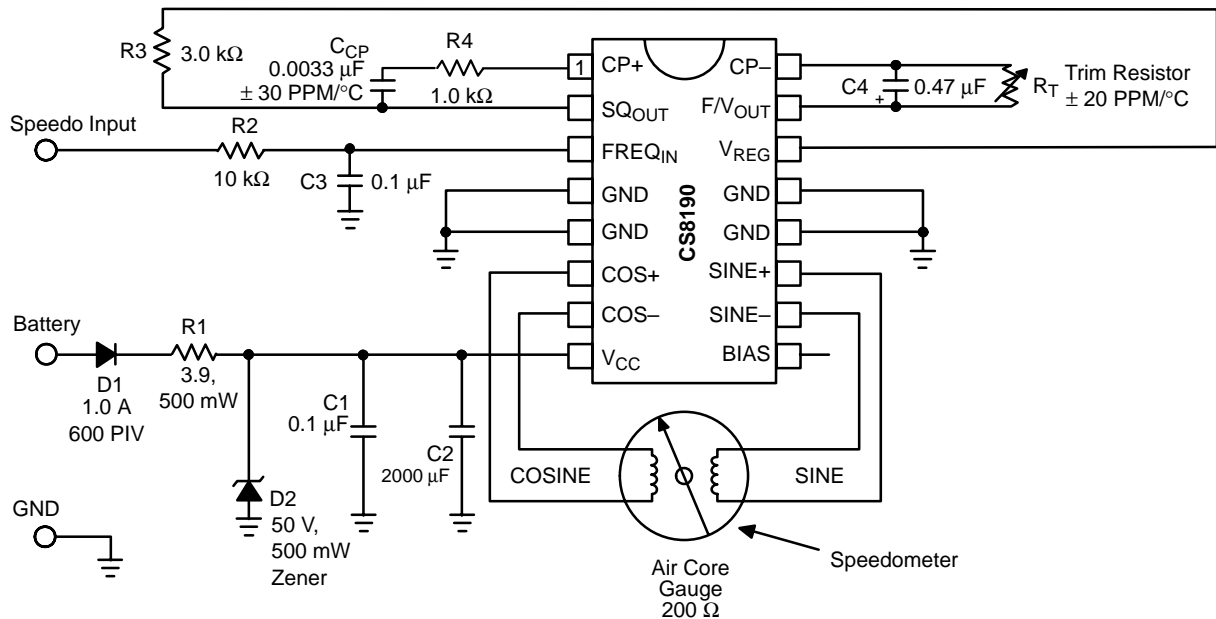
Ripple voltage on the F/V output causes pointer or needle flutter especially at low input frequencies.

The response time of the F/V is determined by the time constant formed by  $R_T$  and  $C_4$ . Increasing the value of  $C_4$  will reduce the ripple on the F/V output but will also increase the response time. An increase in response time causes a very slow meter movement and may be unacceptable for many applications.

The CS8190 has an undervoltage detect circuit that disables the input comparator when  $V_{CC}$  falls below 8.0 V (typical). With no input signal the F/V output voltage decreases and the needle moves towards zero. A second undervoltage detect circuit at 6.0 V (typical) causes the function generator to

generate a differential SIN drive voltage of zero volts and the differential COS drive voltage to go as high as possible. This combination of voltages (Figure 2) across the meter coil moves the needle to the  $0^\circ$  position. Connecting a large capacitor ( $> 2000 \mu\text{F}$ ) to the  $V_{CC}$  lead ( $C_2$  in Figure 9) increases the time between these undervoltage points since the capacitor discharges slowly and ensures that the needle moves towards  $0^\circ$  as opposed to  $360^\circ$ . The exact value of the capacitor depends on the response time of the system, the maximum meter deflection and the current consumption of the circuit. It should be selected by breadboarding the design in the lab.

## CS8190



Notes:

1. C<sub>2</sub> (> 2000 μF) is needed if return to zero function is required.
2. The product of C<sub>4</sub> and R<sub>T</sub> have a direct effect on gain and therefore directly affect temperature compensation.
3. C<sub>4</sub> Range; 20 pF to 0.2 μF.
4. R<sub>4</sub> Range; 100 kΩ to 500 kΩ.
5. The IC must be protected from transients above 60 V and reverse battery conditions.
6. Additional filtering on the FREQ<sub>IN</sub> lead may be required.
7. Gauge coil connections to the IC must be kept as short as possible (≤ 3.0 inch) for best pointer stability.

**Figure 9. Speedometer or Tachometer Application**

### Design Example

Maximum meter Deflection = 270°

Maximum input Frequency = 350 Hz

#### 1. Select R<sub>T</sub> and C<sub>CP</sub>

$$\Theta = 970 \times \text{FREQ} \times C_{CP} \times R_T = 270^\circ$$

Let C<sub>CP</sub> = 0.0033 μF, find R<sub>T</sub>

$$R_T = \frac{270^\circ}{970 \times 350 \text{ Hz} \times 0.0033 \mu\text{F}}$$

$$R_T = 243 \text{ k}\Omega$$

R<sub>T</sub> should be a 250 kΩ potentiometer to trim out any inaccuracies due to IC tolerances or meter movement pointer placement.

#### 2. Select R<sub>3</sub> and R<sub>4</sub>

Resistor R<sub>3</sub> sets the output current from the voltage regulator. The maximum output current from the voltage regulator is 10 mA. R<sub>3</sub> must ensure that the current does not exceed this limit.

Choose R<sub>3</sub> = 3.3 kΩ

The charge current for C<sub>CP</sub> is

$$\frac{V_{REG} - 0.7 \text{ V}}{3.3 \text{ k}\Omega} = 1.90 \text{ mA}$$

C<sub>CP</sub> must charge and discharge fully during each cycle of the input signal. Time for one cycle at maximum frequency is 2.85 ms. To ensure that C<sub>CP</sub> is charged, assume that the

(R<sub>3</sub> + R<sub>4</sub>) C<sub>CP</sub> time constant is less than 10% of the minimum input period.

$$T = 10\% \times \frac{1}{350 \text{ Hz}} = 285 \mu\text{s}$$

Choose R<sub>4</sub> = 1.0 kΩ

Discharge time: t<sub>DCHG</sub> = R<sub>3</sub> × C<sub>CP</sub> = 3.3 kΩ × 0.0033 μF = 10.9 μs

Charge time: t<sub>CHG</sub> = (R<sub>3</sub> + R<sub>4</sub>)C<sub>CP</sub> = 4.3 kΩ × 0.0033 μF = 14.2 μs

#### 3. Determine C<sub>4</sub>

C<sub>4</sub> is selected to satisfy both the maximum allowable ripple voltage and response time of the meter movement.

$$C_4 = \frac{C_{CP}(V_{REG} - 0.7 \text{ V})}{\Delta V_{MAX}}$$

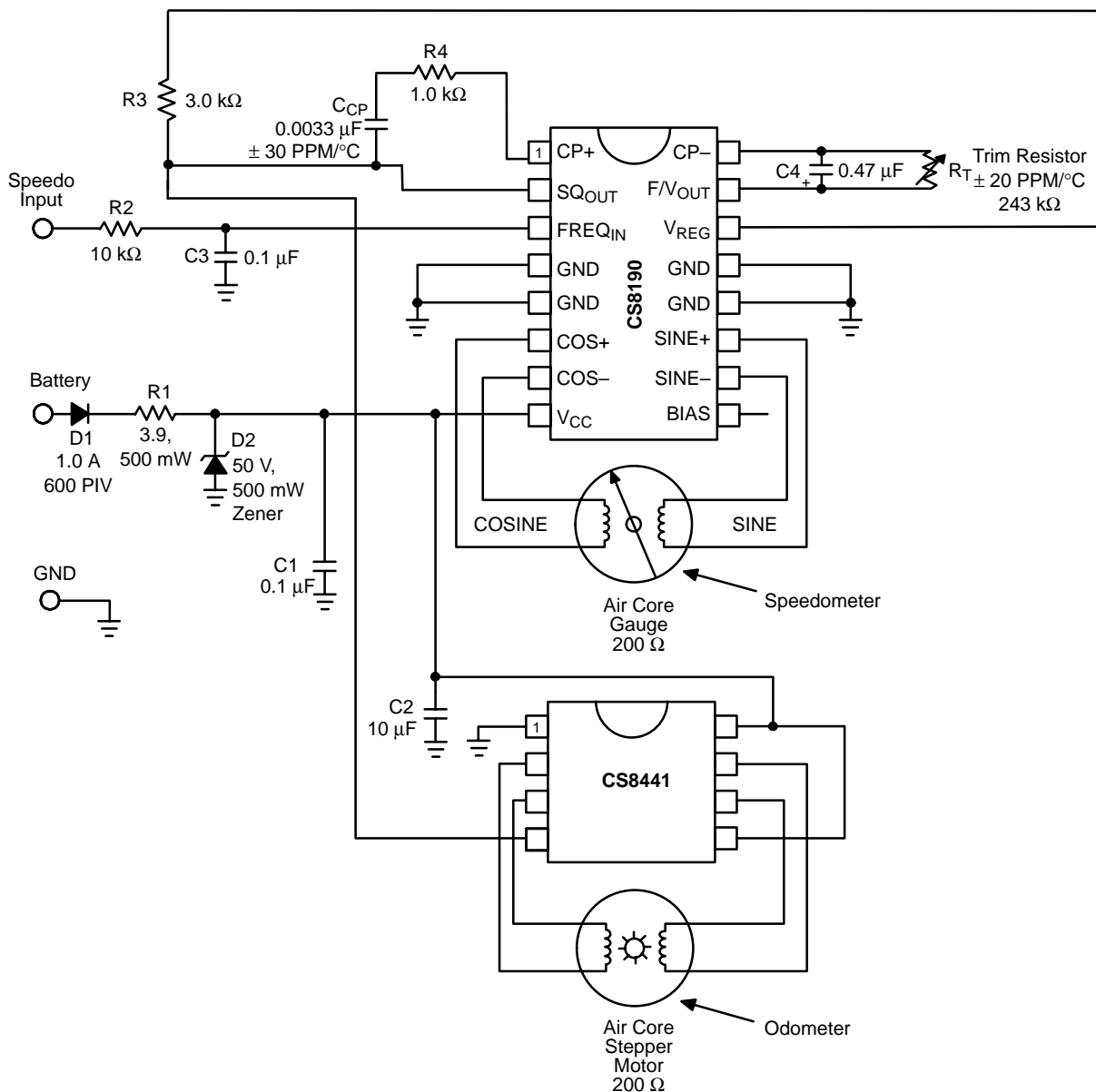
With C<sub>4</sub> = 0.47 μF, the F/V ripple voltage is 44 mV.

The last component to be selected is the return to zero capacitor C<sub>2</sub>. This is selected by increasing the input signal frequency to its maximum so the pointer is at its maximum deflection, then removing the power from the circuit. C<sub>2</sub> should be large enough to ensure that the pointer always returns to the 0° position rather than 360° under all operating conditions.

Figure 10 shows how the CS8190 and the CS8441 are used to produce a Speedometer and Odometer circuit.



## CS8190



### Notes:

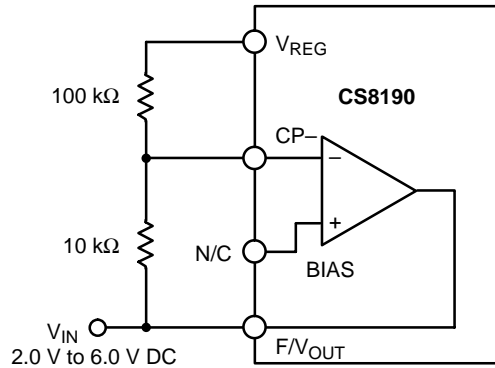
1. C2 = 10  $\mu$ F with CS8441 application.
2. The product of C4 and R<sub>T</sub> have a direct effect on gain and therefore directly affect temperature compensation.
3. C4 Range; 20 pF to 0.2  $\mu$ F.
4. R4 Range; 100 k $\Omega$  to 500 k $\Omega$ .
5. The IC must be protected from transients above 60 V and reverse battery conditions.
6. Additional filtering on the FREQ<sub>IN</sub> lead may be required.
7. Gauge coil connections to the IC must be kept as short as possible ( $\leq$  3.0 inch) for best pointer stability.

**Figure 10. Speedometer With Odometer or Tachometer Application**

## CS8190

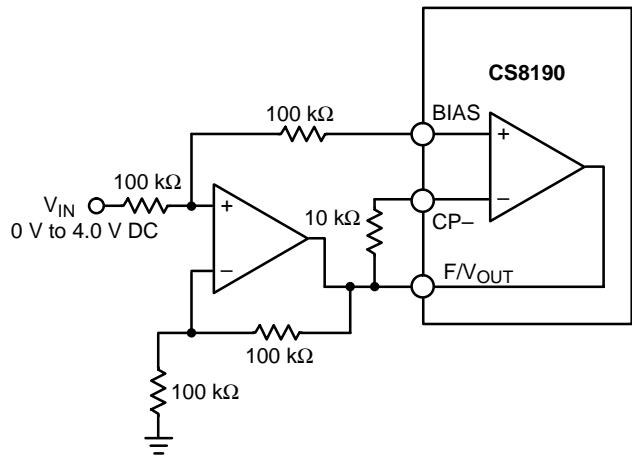
In some cases a designer may wish to use the CS8190 only as a driver for an air-core meter having performed the F/V conversion elsewhere in the circuit.

Figure 11 shows how to drive the CS8190 with a DC voltage ranging from 2.0 V to 6.0 V. This is accomplished by forcing a voltage on the F/V<sub>OUT</sub> lead. The alternative scheme shown in Figure 12 uses an external op amp as a buffer and operates over an input voltage range of 0 V to 4.0 V.



**Figure 11. Driving the CS8190 from an External DC Voltage**

Figures 11 and 12 are not temperature compensated.

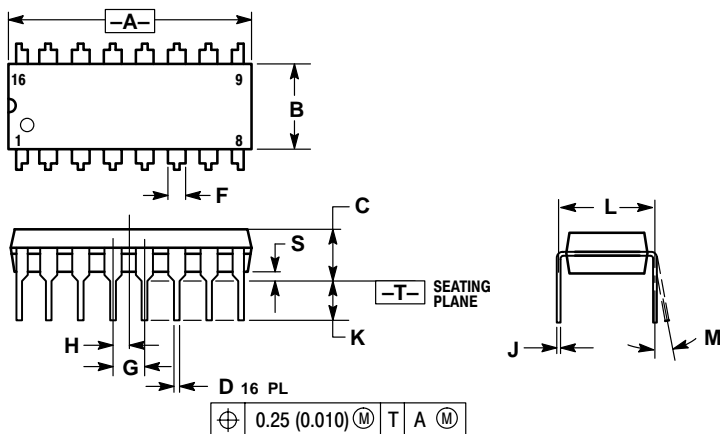


**Figure 12. Driving the CS8190 from an External DC Voltage Using an Op Amp Buffer**

# CS8190

## PACKAGE DIMENSIONS

**DIP-16**  
**NF SUFFIX**  
 CASE 648-08  
 ISSUE R

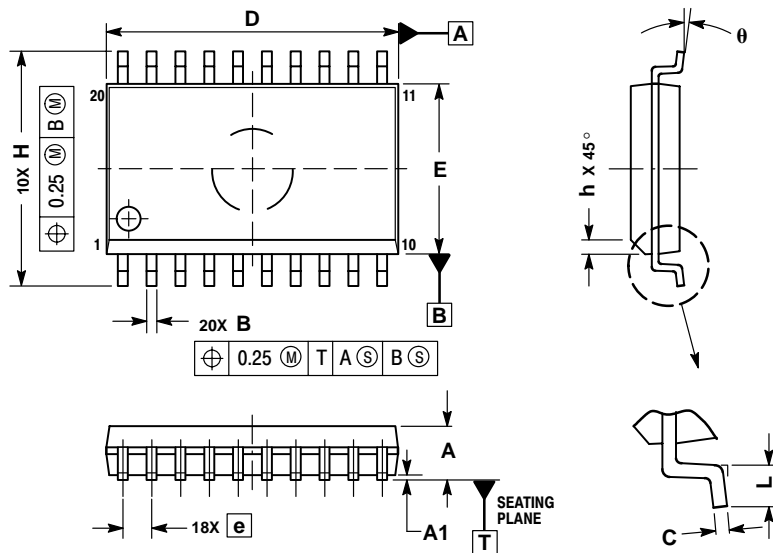


**NOTES:**

- DIMENSIONING AND TOLERANCING PER ANSI Y14.5M, 1982.
- CONTROLLING DIMENSION: INCH.
- DIMENSION L TO CENTER OF LEADS WHEN FORMED PARALLEL.
- DIMENSION B DOES NOT INCLUDE MOLD FLASH.
- ROUNDED CORNERS OPTIONAL.

DIM	INCHES		MILLIMETERS	
	MIN	MAX	MIN	MAX
A	0.740	0.770	18.80	19.55
B	0.250	0.270	6.35	6.85
C	0.145	0.175	3.69	4.44
D	0.015	0.021	0.39	0.53
F	0.040	0.70	1.02	1.77
G	0.100 BSC		2.54 BSC	
H	0.050 BSC		1.27 BSC	
J	0.008	0.015	0.21	0.38
K	0.110	0.130	2.80	3.30
L	0.295	0.305	7.50	7.74
M	0°	10°	0°	10°
S	0.020	0.040	0.51	1.01

**SO-20L**  
**DWF SUFFIX**  
 CASE 751D-05  
 ISSUE F



**NOTES:**


- DIMENSIONS ARE IN MILLIMETERS.
- INTERPRET DIMENSIONS AND TOLERANCES PER ASME Y14.5M, 1994.
- DIMENSIONS D AND E DO NOT INCLUDE MOLD PROTRUSION.
- MAXIMUM MOLD PROTRUSION 0.15 PER SIDE.
- DIMENSION B DOES NOT INCLUDE DAMBAR PROTRUSION. ALLOWABLE PROTRUSION SHALL BE 0.13 TOTAL IN EXCESS OF B DIMENSION AT MAXIMUM MATERIAL CONDITION.

DIM	MILLIMETERS	
	MIN	MAX
A	2.35	2.65
A1	0.10	0.25
B	0.35	0.49
C	0.23	0.32
D	12.65	12.95
E	7.40	7.60
e	1.27 BSC	
H	10.05	10.55
h	0.25	0.75
L	0.50	0.90
theta	0°	7°

**PACKAGE THERMAL DATA**

Parameter		DIP-16	SO-20L	Unit
R <sub>thetaJC</sub>	Typical	15	9	°C/W
R <sub>thetaJA</sub>	Typical	50	55	°C/W

# CS8190

**ON Semiconductor** and  are trademarks of Semiconductor Components Industries, LLC (SCILLC). SCILLC reserves the right to make changes without further notice to any products herein. SCILLC makes no warranty, representation or guarantee regarding the suitability of its products for any particular purpose, nor does SCILLC assume any liability arising out of the application or use of any product or circuit, and specifically disclaims any and all liability, including without limitation special, consequential or incidental damages. "Typical" parameters which may be provided in SCILLC data sheets and/or specifications can and do vary in different applications and actual performance may vary over time. All operating parameters, including "Typicals" must be validated for each customer application by customer's technical experts. SCILLC does not convey any license under its patent rights nor the rights of others. SCILLC products are not designed, intended, or authorized for use as components in systems intended for surgical implant into the body, or other applications intended to support or sustain life, or for any other application in which the failure of the SCILLC product could create a situation where personal injury or death may occur. Should Buyer purchase or use SCILLC products for any such unintended or unauthorized application, Buyer shall indemnify and hold SCILLC and its officers, employees, subsidiaries, affiliates, and distributors harmless against all claims, costs, damages, and expenses, and reasonable attorney fees arising out of, directly or indirectly, any claim of personal injury or death associated with such unintended or unauthorized use, even if such claim alleges that SCILLC was negligent regarding the design or manufacture of the part. SCILLC is an Equal Opportunity/Affirmative Action Employer.

## PUBLICATION ORDERING INFORMATION

### **NORTH AMERICA Literature Fulfillment:**

Literature Distribution Center for ON Semiconductor  
P.O. Box 5163, Denver, Colorado 80217 USA  
**Phone:** 303-675-2175 or 800-344-3860 Toll Free USA/Canada  
**Fax:** 303-675-2176 or 800-344-3867 Toll Free USA/Canada  
**Email:** ONlit@hibbertco.com  
Fax Response Line: 303-675-2167 or 800-344-3810 Toll Free USA/Canada

**N. American Technical Support:** 800-282-9855 Toll Free USA/Canada

### **EUROPE:** LDC for ON Semiconductor – European Support

**German Phone:** (+1) 303-308-7140 (Mon-Fri 2:30pm to 7:00pm CET)  
**Email:** ONlit-german@hibbertco.com  
**French Phone:** (+1) 303-308-7141 (Mon-Fri 2:00pm to 7:00pm CET)  
**Email:** ONlit-french@hibbertco.com  
**English Phone:** (+1) 303-308-7142 (Mon-Fri 12:00pm to 5:00pm GMT)  
**Email:** ONlit@hibbertco.com

**EUROPEAN TOLL-FREE ACCESS\*: 00-800-4422-3781**

\*Available from Germany, France, Italy, UK, Ireland

### **CENTRAL/SOUTH AMERICA:**

**Spanish Phone:** 303-308-7143 (Mon-Fri 8:00am to 5:00pm MST)  
**Email:** ONlit-spanish@hibbertco.com

### **ASIA/PACIFIC:** LDC for ON Semiconductor – Asia Support

**Phone:** 303-675-2121 (Tue-Fri 9:00am to 1:00pm, Hong Kong Time)  
**Toll Free** from Hong Kong & Singapore:  
**001-800-4422-3781**  
**Email:** ONlit-asia@hibbertco.com

### **JAPAN:** ON Semiconductor, Japan Customer Focus Center

4-32-1 Nishi-Gotanda, Shinagawa-ku, Tokyo, Japan 141-0031  
**Phone:** 81-3-5740-2745  
**Email:** r14525@onsemi.com

**ON Semiconductor Website:** <http://onsemi.com>

For additional information, please contact your local Sales Representative.