



# CAT32

## CMOS White LED Driver

### FEATURES

- Low quiescent ground current (0.5mA typical)
- Power efficiency over 80%
- Compatible pinout with LT1932
- Adjustable output current (up to 40mA)
- High frequency 1.2MHz operation
- Input voltage operation down to 2.0V
- Low resistance (0.5Ω) high voltage power switch
- Drives up to 4 White LEDs in series
- Shutdown current less than 1μA
- Load fault protection against open-circuits
- Low value external components
- Low profile (1mm) 6-lead SOT23 and TDFN (0.8mm) package

### APPLICATIONS

- Color LCD and keypad backlighting
- Cellular phones
- Handheld terminals
- Digital cameras
- PDAs/Games
- Portable MP3 players

### DESCRIPTION

The CAT32 is a DC/DC step up converter that delivers a regulated output current. Operation at a constant switching frequency of 1.2MHz allows the device to be used with very small value external inductor and ceramic capacitors.

The CAT32 is targeted to drive multiple white light-emitting diodes (LEDs) connected in series and provides the necessary regulated current to control the brightness and the color purity. An external resistor  $R_{SET}$  controls the output current level. LED currents of up to 40mA can be supported over a wide range of input supply voltages from 2V to 7V, making the device ideal for battery-powered applications.

A high voltage output stage allows up to 4 White LEDs to be driven in series. Series drive provides inherent current matching.

LED dimming can be done by using a DC voltage, a logic signal, or a pulse width modulation (PWM) signal. The shutdown input pin allows the device to be placed in power-down mode with "near zero" quiescent current.

In addition to overcurrent limiting protection, the device also includes detection circuitry to ensure protection against open-circuit load fault conditions.

The device is available in a low profile (1 mm max height) 6-lead thin SOT23 package and in a TDFN (0.8mm max height) package.

### TYPICAL APPLICATION

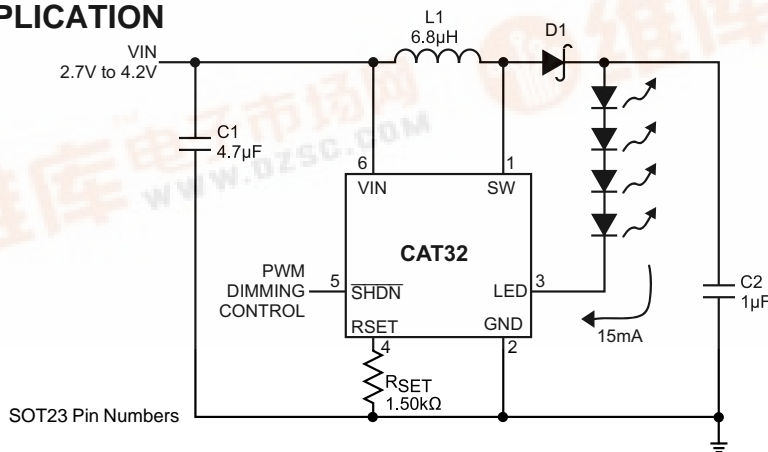

- C1: Taiyo Yuden JMK212BJ475
- C2: Taiyo Yuden EMK212BJ105
- D1: Zetex ZHCS400
- L1: Sumida CLQ4D106R8 (Panasonic ELJEA6R8)

Figure 1. Li-Ion Driver for Four High-Brightness White LEDs



## CAT32

### ORDERING INFORMATION

Part Number	Package	Tube Quantity	Reel Quantity	Package Marking Code
CAT32EKT-TE7	6-lead, thin SOT23	—	3000	BD
CAT32RD4-TE7	8-pad TDFN (3x3mm)	—	3500	CCEM
CAT32RD4	8-pad TDFN (3x3mm)	120	—	CCEM
CAT32TDI-TE7	6-lead thin SOT23, Lead Free	—	3000	LL

### PIN CONFIGURATION

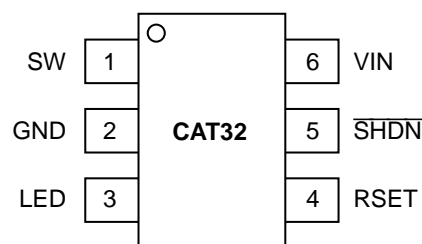

6-Lead SOT-23  
1mm maximum height

$$\theta_{JA} = 250^{\circ}\text{C/W}$$

[Free Air]

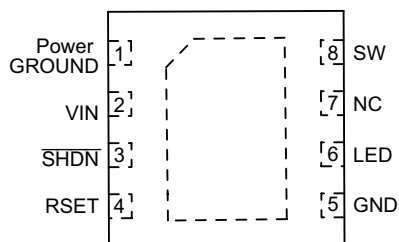

(Top View)  
TDFN Package: 3mm x 3mm  
0.8mm maximum height  
(RD4)

### PIN DESCRIPTIONS

Pin Number SOT23	Pin Number TDFN	Name	Function
1	8	SW	Switch pin. This is the drain of the internal power switch. For minimum EMI, minimize the trace area connected to this pin.
2	5	GND	Ground pin. Connect pin 2 to ground.
3	6	LED	LED (cathode) connection pin.
4	4	RSET	RESET pin. A resistor connected from pin 4 to ground sets the LED current. This pin is also used to dim the LEDs.
5	3	SHDN	Shutdown pin.
6	2	VIN	Input supply pin. This pin should be bypassed with a capacitor to ground. A 4.7μF capacitor mounted close to the pin is recommended.
—	1	Power Ground	Power Ground

## ABSOLUTE MAXIMUM RATINGS

These are stress ratings only and functional operation is not implied. Exposure to absolute maximum ratings for prolonged time periods may affect device reliability. All voltages are with respect to ground.

$V_{IN}$ , LED, $\overline{SHDN}$ Voltage .....	8V	Lead Soldering Temperature (10 secs) .....	300°C
SW Voltage .....	20V	Storage Temperature .....	-65°C to 150°C
RSET Voltage .....	1V	ESD Rating - Human Body Model .....	2000V
Junction Temperature .....	125°C		

## RECOMMENDED OPERATING CONDITIONS

Parameter	Range	Unit
$V_{IN}$	2 to 7	V
Ambient Temperature Range	-40 to +85	° C
Inductor L1	6.8 ±20% typical	µH
Input Capacitor C1	4.7 ±20% typical	µF
Output Capacitor C2	1.0 ±20% typical	µF
$I_{LED}$ with 1 to 4 LEDs in series	0 to 20	mA

## ELECTRICAL SPECIFICATIONS

Over recommended operating conditions unless otherwise specified.  $T_A = 25^\circ\text{C}$ ,  $V_{IN} = 2\text{V}$  and  $V_{\overline{SHDN}} = 1.2\text{V}$ .

Symbol	Parameter	Conditions	Min	Typ	Max	Units
$I_Q$	Quiescent Current	$V_{RSET} = 0.2\text{V}$		0.5	0.7	mA
$I_{GND}$	Ground Current in Shutdown	$V_{\overline{SHDN}} = 0\text{V}$		0.05	1	µA
$V_{LED}$	LED Pin Voltage	$V_{IN} < V_{OUT}$ , $I_{LED} = 15\text{mA}$		120	180	mV
$I_{LED}$	LED Current Adjust Range		5		40	mA
$I_{LED}$	Programmed LED Current	$R_{SET} = 562\Omega$	33	38	45	mA
		$R_{SET} = 750\Omega$	25	30	36	
		$R_{SET} = 1.5\text{k}\Omega$	12.5	15	17.5	
		$R_{SET} = 4.53\text{k}\Omega$		5		
$I_{LED}$	LED Pin Current Temperature Coefficient	$I_{LED} = 15\text{mA}$		-0.01		mA/° C
$V_{RSET}$	$R_{SET}$ Pin Voltage	$R_{SET} = 1.5\text{k}\Omega$		100		mV
	Shutdown Pin Logic High Level		0.85			V
	Shutdown Pin Logic Low Level				0.25	V
$f_{SW}$	Boost Converter Frequency		0.8	1.2	1.6	MHz
$I_{SWL}$	Switch Current Limit		400	550	780	mA
$R_{SW}$	Switch Resistance	$V_{IN} = 2\text{V}$ , $I_{SW} = 100\text{mA}$		0.7	1.2	Ω
		$V_{IN} = 3\text{V}$ , $I_{SW} = 100\text{mA}$		0.5	0.9	Ω
	Switch Leakage Current	Switch Off, $V_{SW} = 5\text{V}$		0.01	5	µA
	Efficiency	Components shown on Figure 1		83		%

**TYPICAL CHARACTERISTICS**

$V_{IN}=3.6V$ ,  $T_{AMB}=25^{\circ}C$ ,  $C_{IN}=4.7\mu F$ ,  $C_{OUT}=1\mu F$ ,  $L=6.8\mu H$ , unless otherwise specified.

**Quiescent Current vs. Input Voltage**

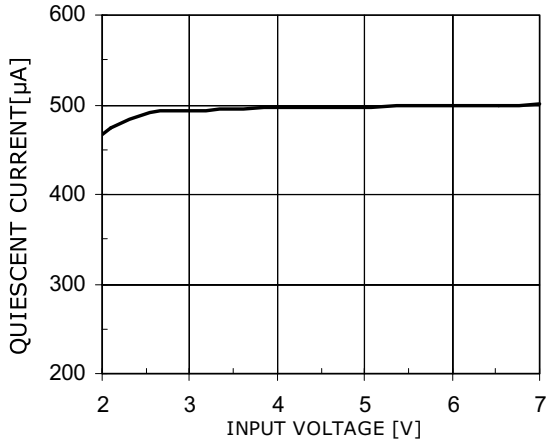

**Quiescent Current vs. Temperature**

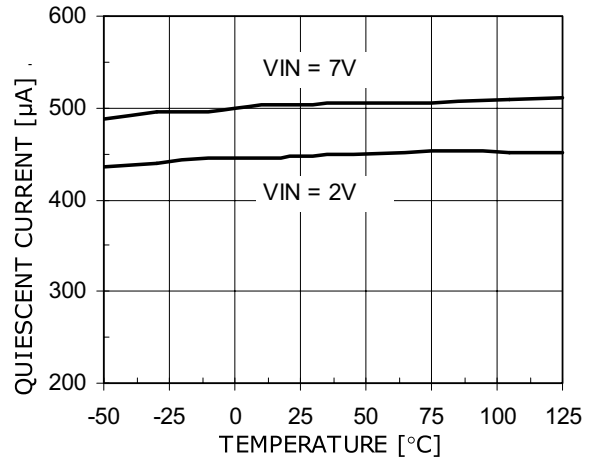

**Switching Frequency vs. Input Voltage**

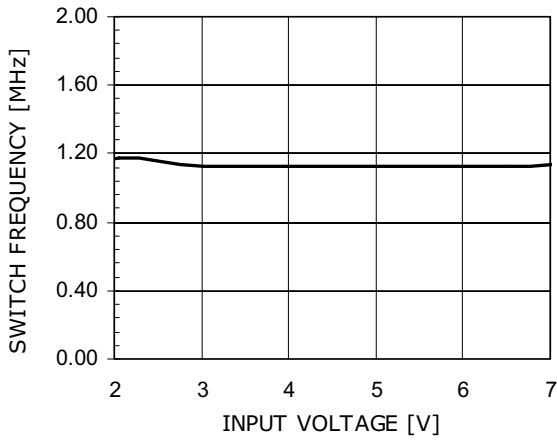

**Switching Frequency vs. Temperature**

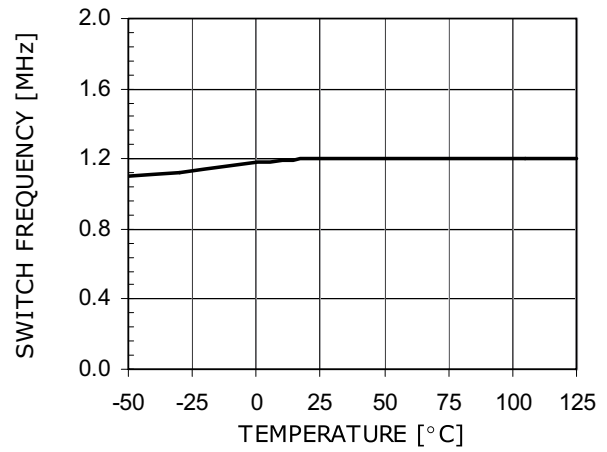

**LED Current vs. Input Voltage**

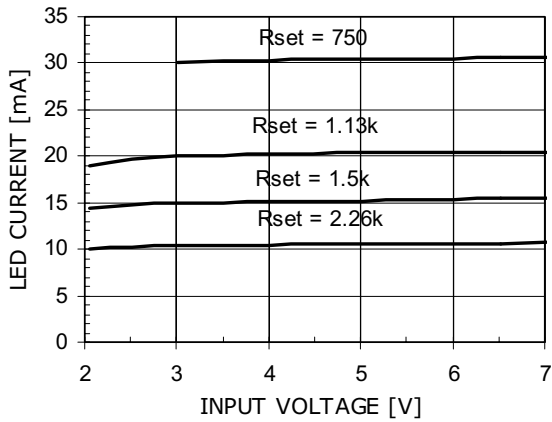

**LED Current vs. Temperature**

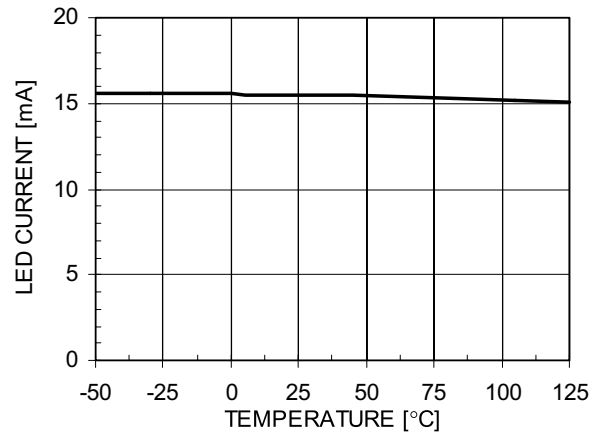

**TYPICAL CHARACTERISTICS**

$V_{IN}=3.6V, T_{AMB}=25^{\circ}C, C_{IN}=4.7\mu F, C_{OUT}=1\mu F, L=6.8\mu H$ , unless otherwise specified.

**Switch Resistance vs. Input Voltage**

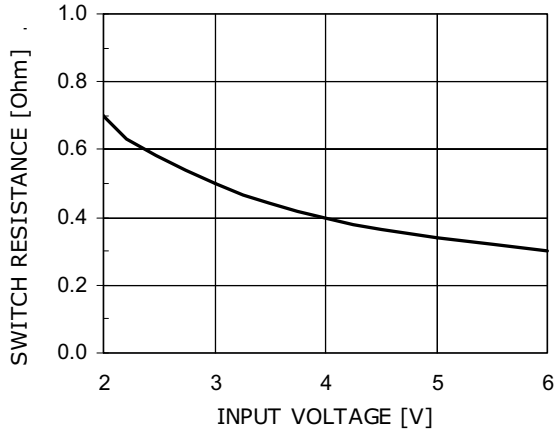

**Switch Resistance vs. Temperature**

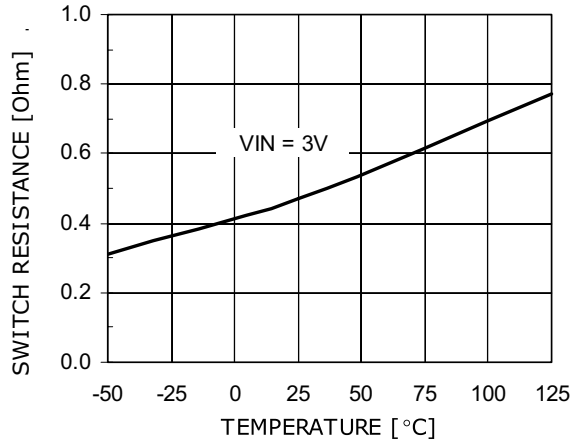

**LED Pin Voltage vs. LED current**

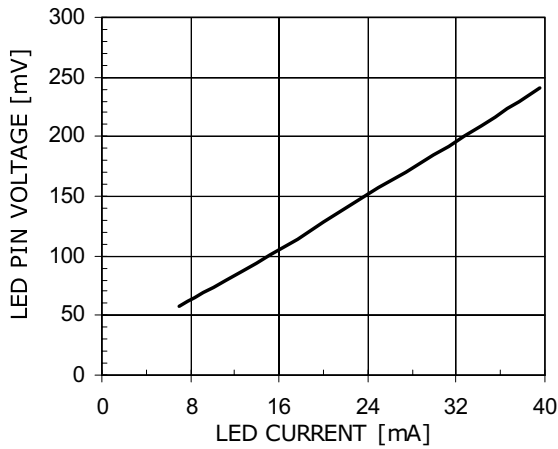

**Vsw, I<sub>L</sub>, & Vout Signal Waveforms**

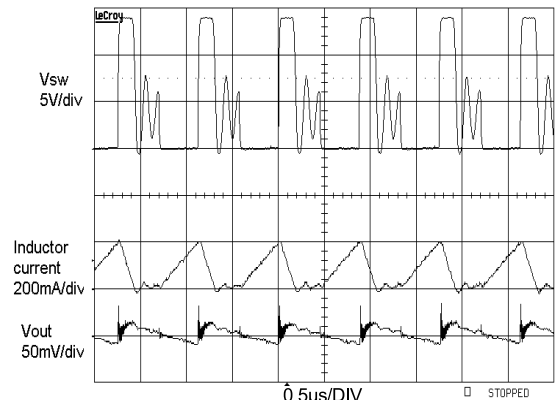

VIN = 3.7V with 15mA load through 4 LEDs

**Efficiency vs. Input Voltage**

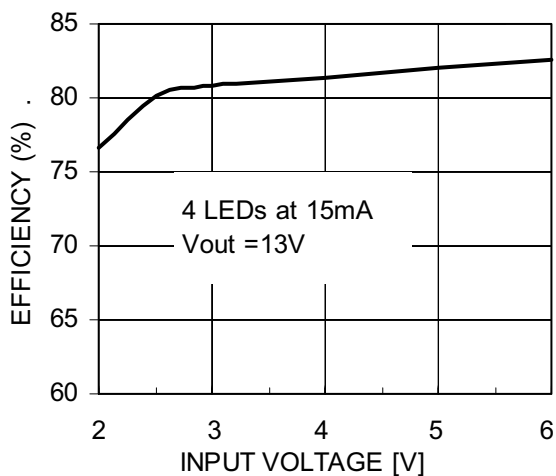

**PWM on SHDN pin Waveform**

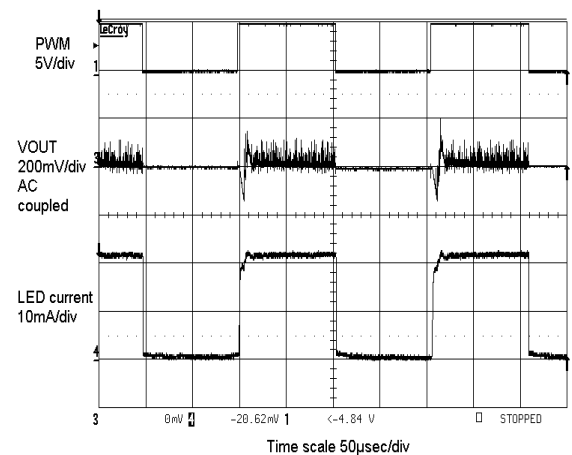

# CAT32

## OPERATION

The CAT32 device is a high efficiency, constant frequency, current regulating boost converter.

The device includes a switch and an internally compensated loop for the regulation of the LED current.

Operation can be best understood by examining the block diagram. The RSET pin is regulated at 100mV and the current through the external resistor will set the regulated current in the LEDs (from 5mA to 40mA) with a multiplication factor of 225.

While maintaining LED current regulation, the CAT32 automatically adjusts the LED pin voltage to be as low as

possible. A low LED pin voltage ensures high efficiency.

Current through the internal power switch is continuously monitored cycle-by-cycle. If the current limit is exceeded, the switch is immediately turned off, protecting the device, for the remainder of the cycle.

PWM dimming operation can be achieved by switching the SHDN pin or by pulling the RSET pin higher than 0.1V.

## BLOCK DIAGRAM

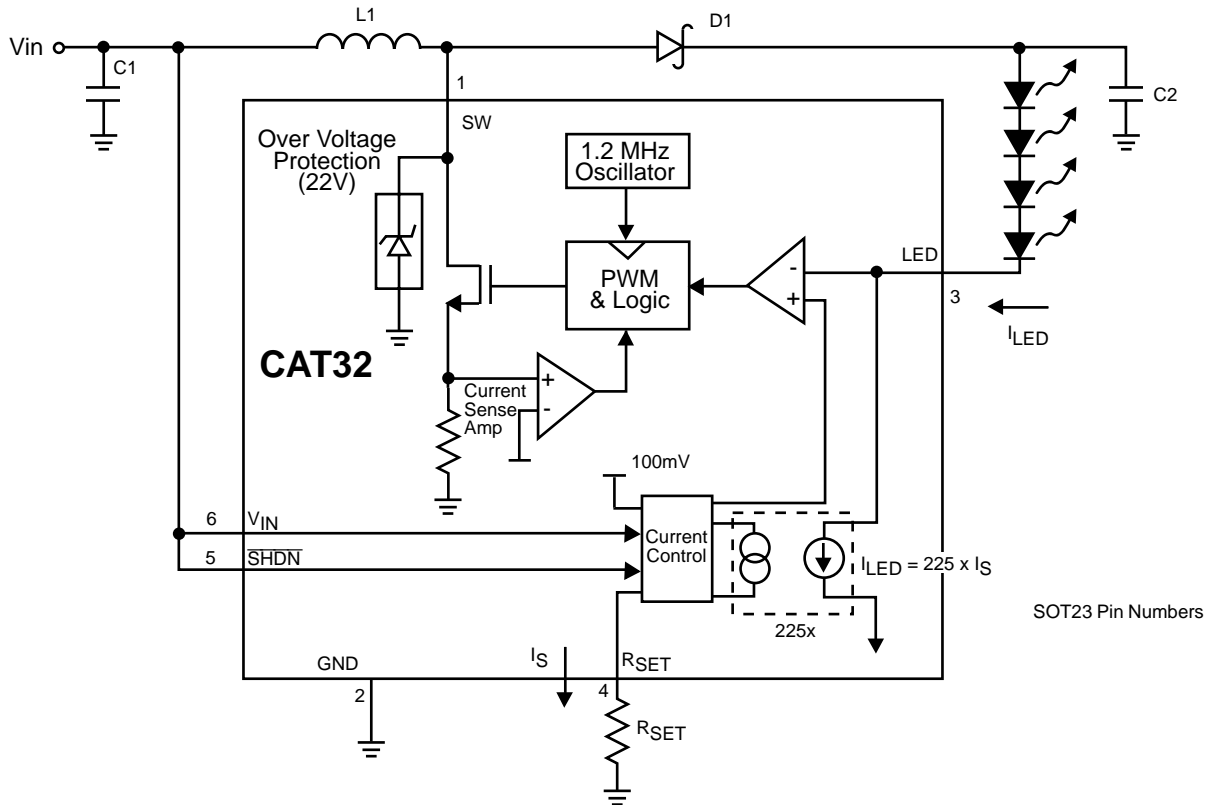

Figure 2. CAT32 Block Diagram

## APPLICATION INFORMATION

### Inductor Selection and Efficiency

Inductor vendors are shown below. Contact the manufacturer for detailed technical data and new product information.

Table 1: Inductor Manufacturers

Inductor	L ( $\mu$ H)	Maximum DCR ( $m\Omega$ )	Maximum Height (mm)	Vendor	Web
ELJEA4R7	4.7	180	2.2	Panasonic 714.373.7334	www.panasonic.com
ELJEA6R8	6.8	250	2.2		
LQH3C4R7M24, LQH32CN4R7M11	4.7	260	2.2	Murata 770.436.1300	www.murata.com
LQH3C100K24, LQH32CN100K11	10	300	2.2		
LB2016B4R7	4.7	250	2.0	Taiyo Yuden 408.573.4150	www.t-yuden.com
LB2016B100	3.8	350	2.0		
CMD4D06-4R7	4.7	216	0.8	Sumida 847.956.0666	www.sumida.com
CMD4D06-6R8	6.8	296	0.8		
CLQ4D10-4R7	4.7	162	1.2		
CLQ4D10-6R8	6.8	195	1.2		

### CAPACITOR SELECTION

Low ESR (equivalent series resistance) capacitors should be used at the output to minimize the output ripple voltage. The low ESR and small package options available with multilayer ceramic capacitors make them excellent choices. The X5R and X7R capacitor types are preferred because they retain their capacitance over wider voltage and temperature ranges than the Y5V or Z5U types. A  $1.0\mu$ F or  $2.2\mu$ F output capacitor is recommended for most applications.

The voltage rating of the output capacitor C2 depends on the number of LEDs driven in series. A 10V ceramic capacitor is recommended when driving two LEDs. A 16V ceramic capacitor is recommended when driving 3 or 4 LEDs.

Low profile ceramic capacitors with a 1mm maximum height/thickness are available for designs height requirements. Ceramic capacitors also make a good choice for the input capacitor, which should be mounted as close as possible to the CAT32. A  $2.2\mu$ F or  $4.7\mu$ F input capacitor is recommended. Table 2 shows a list of several ceramic capacitor manufacturers. Consult the manufacturers for detailed information as new products and package options are introduced regularly.

Table 2: Ceramic Capacitor Manufacturers

Supplier	Phone	Web
Taiyo Yuden	408.573.4150	www.t-yuden.com
Murata	814.237.1431	www.murata.com
Kemet	408.986.0424	www.kemet.com

### DIODE SELECTION

Schottky diodes, with their low forward voltage drop and fast switching speed, are the ideal choice for high efficiency applications. Table 3 shows several different Schottky diodes that work well with the CAT32. Make sure that the diode has a voltage rating greater than the

output voltage. The diode conducts current only when the power switch is turned off (typically less than one-third the time), so a 0.4A or 0.5A diode will be sufficient for most designs.

Table 3: Schottky Diode Suppliers

Part	Supplier
MBR0520	ON Semiconductor
MBR0530	www.onsemi.com
MBR0540	800.282.9855
ZHCS400	Zetex

### LED CURRENT PROGRAMMING

The LED current is programmed with a single resistor connected to the RSET pin. The RSET pin is internally regulated to 100mV, which sets the current flowing out of this pin, I<sub>SET</sub>, equal to 100mV/RSET. The CAT32

regulates the current into the LED pin, I<sub>LED</sub>, to 225 times the value of I<sub>SET</sub>. For the best accuracy, a 1% or better resistor is recommended. Table 4 shows several typical 1% R<sub>SET</sub> values.

Table 4: RSET Resistor Values

I <sub>LED</sub> (mA)	RSET
40	562Ω
30	750Ω
25	909Ω
20	1.13kΩ
15	1.50kΩ
10	2.26kΩ
5	4.53kΩ

For other LED current values, use the following equation to choose R<sub>SET</sub>.

$$R_{SET} = 225 \times \left( \frac{0.1V}{I_{LED}} \right)$$

Most white LEDs are driven at maximum currents of 15mA to 20mA. Some higher power designs will use two parallel strings of LEDs for greater light output, resulting in 30mA to 40mA (two strings of 15mA to 20mA) flowing into the LED pin.



## LED DIMMING WITH PWM SIGNAL

PWM brightness control provides the widest dimming range (greater than 20:1). By turning the LEDs ON and OFF using the control signal the LEDs operate at either zero or full current, but their average current changes with the PWM signal duty cycle. Typically, a 5kHz to 40kHz PWM signal is used. PWM dimming with the CAT32 can be accomplished two different ways.

The  $\overline{\text{SHDN}}$  pin can be driven directly or a resistor can be added to drive the RSET pin. If the  $\overline{\text{SHDN}}$  pin is used, increasing the duty cycle will increase the LED brightness. Using this method, the LEDs can be dimmed and turned off completely using the same control signal. A 0% duty cycle signal will turn off the CAT32, reducing the total quiescent current to near zero.

If the RSET pin is used, increasing the duty cycle will decrease the brightness. Using this method, the LEDs are dimmed using RSET and turned off completely using SHDN. If the RSET pin is used to provide PWM dimming, the approximate value of  $R_{\text{PWM}}$  should be calculated (where  $V_{\text{MAX}}$  is the "HIGH" value of the PWM signal):

$$R_{\text{PWM}} = R_{\text{SET}} \times \left( \frac{V_{\text{MAX}}}{0.15\text{V}} - 1 \right)$$

## LED DIMMING WITH A LOGIC SIGNAL

For applications that need to adjust the LED brightness in discrete steps, a logic signal can be used.  $R_{\text{MIN}}$  sets the minimum LED current value (when the NMOS is OFF):

$$R_{\text{MIN}} = 225 \times \left( \frac{0.1\text{V}}{I_{\text{LED(MIN)}}} \right)$$

In addition to providing the widest dimming range, PWM brightness control also ensures the "purest" white LED color over the entire dimming range. The true color of a white LED changes with operating current, and is the "purest" white at a specific forward current, usually 15mA or 20mA. If the LED current is less than or more than this value, the emitted light becomes more blue. Applications involving color LCDs can find the blue tint objectionable.

When a PWM control signal is used to drive the  $\overline{\text{SHDN}}$  pin of the CAT32, the LEDs are turned off and on at the PWM frequency. The current through them alternates between full current and zero current, so the average current changes with duty cycle. This ensures that when the LEDs are on, they can be driven at the appropriate current to give the purest white light. LED brightness varies linearly with the PWM duty cycle.

$R_{\text{INCR}}$  determines how much LED current increases when the external NMOS switch is turned ON.

$$R_{\text{INCR}} = 225 \times \left( \frac{0.1\text{V}}{I_{\text{LED(Increase)}}} \right)$$

## LED DIMMING WITH A DC VOLTAGE

$$R_{\text{ADJ}} = 225 \times \left( \frac{V_{\text{MAX}} - 0.1\text{V}}{I_{\text{LED(MAX)}} - I_{\text{LED(MIN)}}} \right)$$

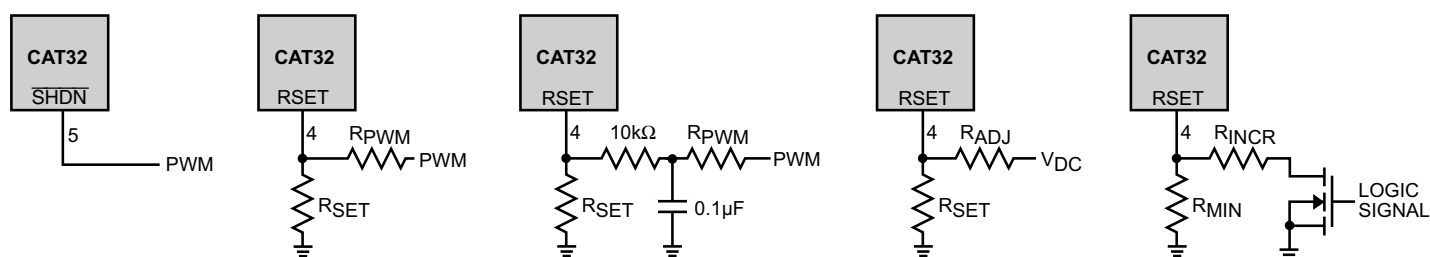

Figure 3: LED Dimming Circuits

# CAT32

## PCB LAYOUT GUIDELINES

The CAT32 is a high-frequency switching regulator and therefore proper PCB board layout and component placement can minimize noise and radiation and increase efficiency. To maximize efficiency, the CAT32 design has fast switch rise and fall times. To prevent radiation and high frequency resonance problems minimize the length and area of all traces connected to the SW pin and

use a ground plane under the switching regulator.

The switch, schottky output diode and output capacitor signal path should be kept as short as possible. The ground connection for the  $R_{SET}$  resistor should be tied directly to the GND pin and not be shared with other components.

## TYPICAL APPLICATION CIRCUITS

The application diagrams below are shown for the SOT23 packages.

### Two LEDs with DC Level Dimming Control:

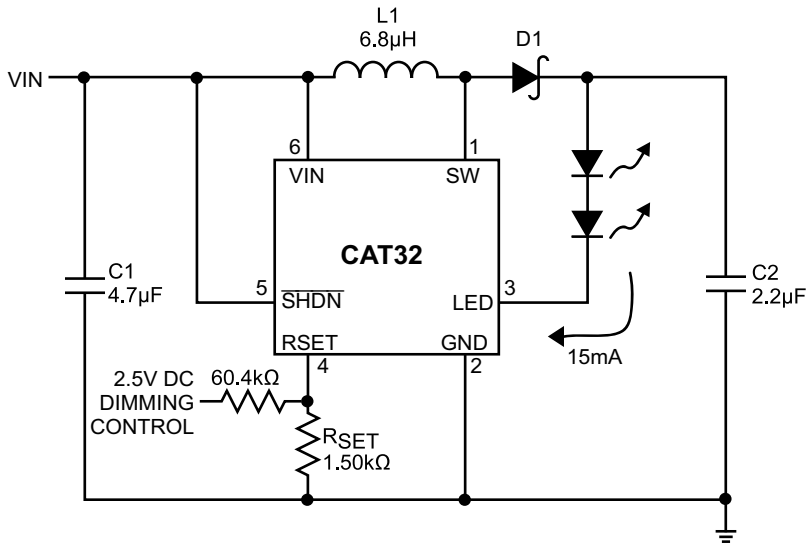

### Three LEDs with DC Level Dimming Control:

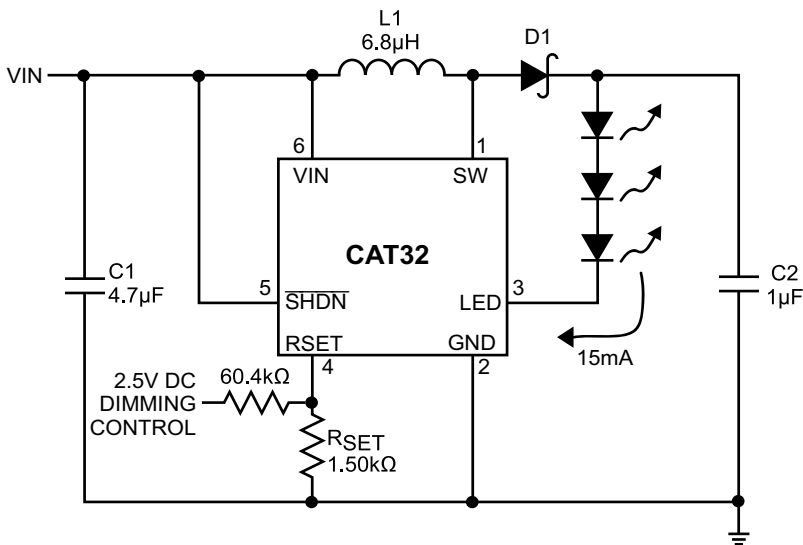

### Efficiency - Three LEDs

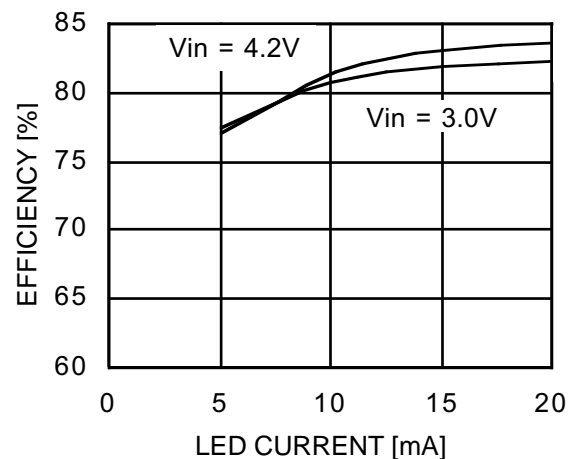

Four LEDs with PWM Dimming Control:

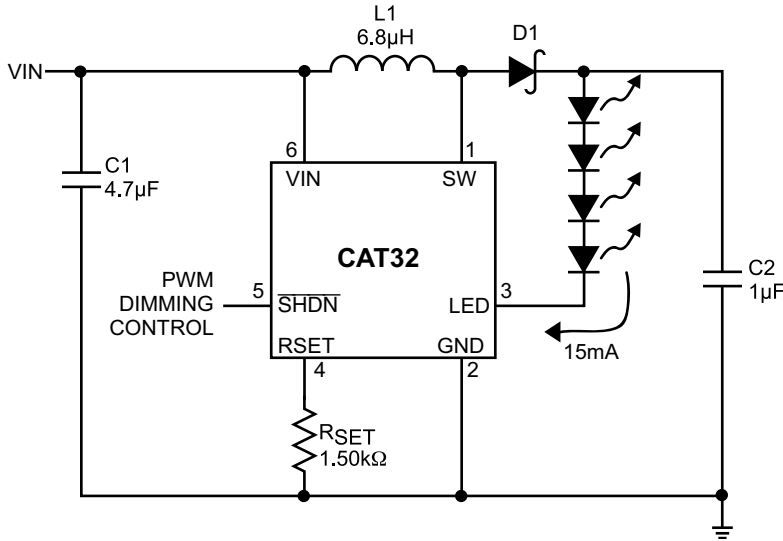

Efficiency - Four LEDs

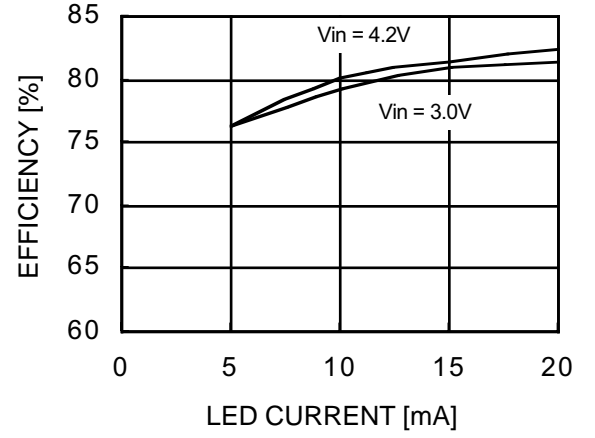

**PACKAGE OUTLINES**  
**6 LEAD SOT-23**  
**(AA OPTION)**

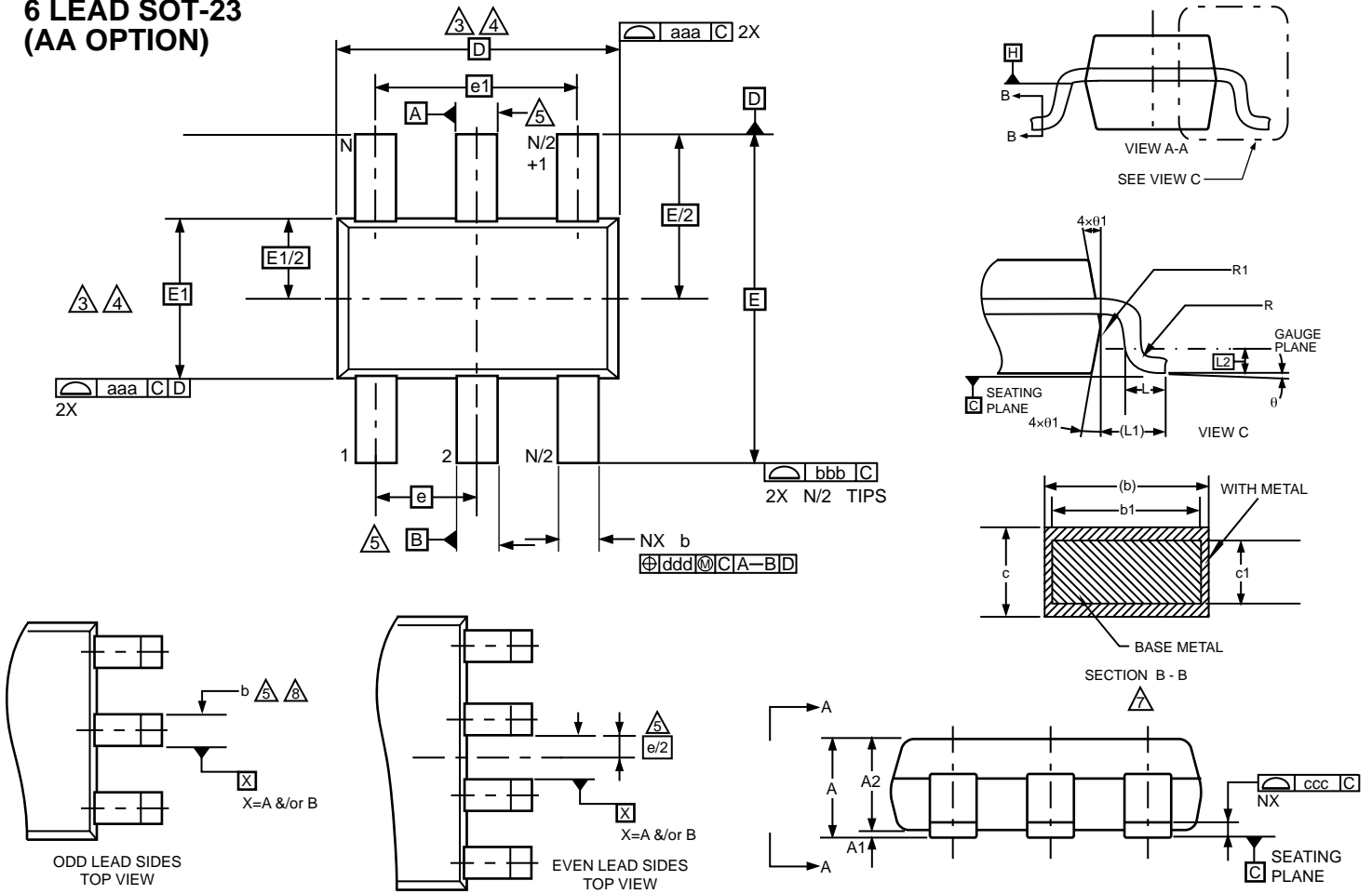

All Dimensions are in Millimeters

	Min	Nom	Max	Notes
A	—	—	1.00	
A1	0.01	0.05	0.10	
A2	0.84	0.87	0.90	
c	0.12	0.15	0.20	7
c1	0.08	0.13	0.16	7
D	2.90BSC			3,4
E	2.80BSC			3,4
E1	1.60BSC			3,4
L	0.30	0.40	0.50	
L1	0.60REF			
L2	0.25BSC			
R	0.10	—	—	
R1	0.10	—	0.25	
θ	0°	4°	8°	
θ1	4°	10°	12°	

Tolerances of Form and Position		Notes								
aaa	0.15	1,2								
bbb	0.25	1,2								
ccc	0.10	1,2								
Variations										
AA			△ AB			BA				
	Min	Nom	Max	Min	Nom	Max	Min	Nom	Max	Notes
b	0.30	—	0.45	0.30	—	0.45	0.22	—	0.36	7,8
b1	0.31	0.35	0.39	0.31	0.35	0.39	0.22	0.26	0.30	
e	0.95BSC			0.95BSC			0.65BSC			
e1	1.90BSC			1.90BSC			1.95BSC			
N	6			5			8			
Tolerances of Form and Position										
ddd	0.20			0.20			0.13			1,2

**Notes:**

1. Dimensions and tolerancing per ASME Y14.5M - 1994
2. Dimension are in mm.
3. Dimension D does not include mold flash, protrusions or gate burrs. Mold flash, protrusions or gate burrs shall not exceed 0.15mm per end. Dimension E1 does not include interlead flash or protrusion. Interlead flash or protrusion shall not exceed 0.15mm per side. D and E1 dimensions are determined at Datum H.

- △ The package top may be smaller than the package bottom. Dimensions D and E1 are determined at the outermost extremes of the plastic body exclusive of mold flash, the bar burrs, gate burrs and interlead flash, but including any mismatch between the top and bottom of the plastic body. D and E1 dimensions are determined at Datum H.
- △ Datums A & B to be determined at Datum H.
- △ Package variation "AB" is a 5 lead version of the 6 lead variation "AA" where lead #5 has been removed from the 6 lead "AA" variation.
- △ These dimensions apply to the flat section of the lead between 0.08mm and 0.15mm from the lead tip.
- △ Dimension "b" does not include dambar protrusion. Allowable dambar protrusion shall be 0.08mm total in excess of the "b" dimension at maximum material condition. The dambar cannot be located on the lower radius of the foot. Minimum space between protrusion and an adjacent lead shall not be less than 0.07mm.

TDFN 3X3 PACKAGE (RD4)

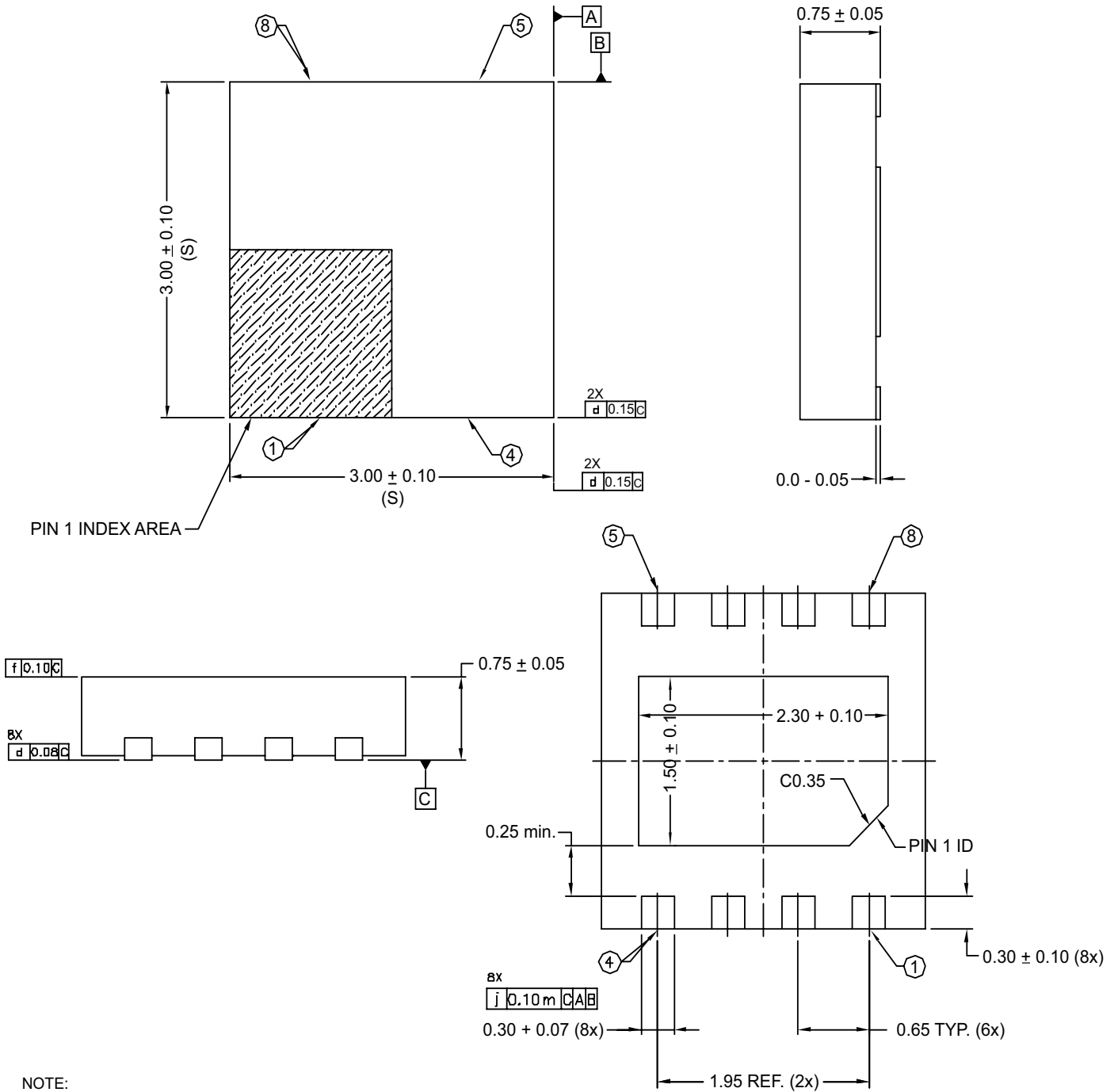

NOTE:

1. ALL DIMENSION ARE IN mm. ANGLES IN DEGREES.
2. COPLANARITY SHALL NOT EXCEED 0.08 mm.
3. WARPAGE SHALL NOT EXCEED 0.10 mm.
4. PACKAGE LENGTH / PACKAGE WIDTH ARE CONSIDERED AS SPECIAL CHARACTERISTIC(S)
5. REFER JEDEC MO-229 / WEEC

## REVISION HISTORY

Date	Rev.	Reason
10/9/2003	AA	Revised Typical Characteristics plots
2/11/2004	AB	Revised Efficiency plots
11/1/2004	AC	Added Green package designation Eliminated TDFN (3x4.9mm) package

---

### Copyrights, Trademarks and Patents

Trademarks and registered trademarks of Catalyst Semiconductor include each of the following:

DPP™ AE<sup>2</sup>™

Catalyst Semiconductor has been issued U.S. and foreign patents and has patent applications pending that protect its products. For a complete list of patents issued to Catalyst Semiconductor contact the Company's corporate office at 408.542.1000.

*CATALYST SEMICONDUCTOR MAKES NO WARRANTY, REPRESENTATION OR GUARANTEE, EXPRESS OR IMPLIED, REGARDING THE SUITABILITY OF ITS PRODUCTS FOR ANY PARTICULAR PURPOSE, NOR THAT THE USE OF ITS PRODUCTS WILL NOT INFRINGE ITS INTELLECTUAL PROPERTY RIGHTS OR THE RIGHTS OF THIRD PARTIES WITH RESPECT TO ANY PARTICULAR USE OR APPLICATION AND SPECIFICALLY DISCLAIMS ANY AND ALL LIABILITY ARISING OUT OF ANY SUCH USE OR APPLICATION, INCLUDING BUT NOT LIMITED TO, CONSEQUENTIAL OR INCIDENTAL DAMAGES.*

Catalyst Semiconductor products are not designed, intended, or authorized for use as components in systems intended for surgical implant into the body, or other applications intended to support or sustain life, or for any other application in which the failure of the Catalyst Semiconductor product could create a situation where personal injury or death may occur.

Catalyst Semiconductor reserves the right to make changes to or discontinue any product or service described herein without notice. Products with data sheets labeled "Advance Information" or "Preliminary" and other products described herein may not be in production or offered for sale.

Catalyst Semiconductor advises customers to obtain the current version of the relevant product information before placing orders. Circuit diagrams illustrate typical semiconductor applications and may not be complete.

---



# CATALYST

Catalyst Semiconductor, Inc.  
Corporate Headquarters  
1250 Borregas Avenue  
Sunnyvale, CA 94089  
Phone: 408.542.1000  
Fax: 408.542.1200  
www.catalyst-semiconductor.com

Publication #: 5001  
Revision: AC  
Issue date: 11/1/04  
Type: Preliminary