

Sync Separator w/50% Slice, AGC

élantec

The EL1882C video sync separator is manufactured using Elantec's high performance analog CMOS process.

This device extracts sync timing information from both standard and non-standard video input. It provides composite sync, vertical sync, burst/back porch timing and odd/even field detection. 50% sync tip slicing provides precise sync edge detection when the video input level is between 0.5V_{P-P} and 2V_{P-P} (sync tip amplitude 143mV to 572mV). A single external resistor sets all internal timing to adjust for various video standards. The **composite sync** output follows **video in** sync pulses, and a **vertical sync** pulse is output on the rising edge of the first vertical serration following the vertical pre-equalizing string. For non-standard vertical inputs, a default vertical pulse is output when the vertical signal stays low for longer than the vertical sync default delay time. The **odd/even** output indicates field polarity detected during the vertical blanking interval. The EL1882C is plug-in compatible with the industry standard LM1881 and can be substituted for that part in 5V applications with improved 50% slicing and lower required supply current.

Ordering Information

PART NO.	TEMP. RANGE	PACKAGE	PKG. NO.
EL1882CN	-40°C to +85°C	8-pin DIP	MDP0031
EL1882CS	-40°C to +85°C	8-lead SO	MDP0027

Features

- NTSC, PAL, SECAM, non-standard video sync separation
- Precision 50% slicing of video input levels from 0.5V_{P-P} to 2V_{P-P}
- Low supply current - 1.5mA typ.
- Single +5V supply
- Composite, vertical sync output
- Odd/Even field output
- Burst/Back porch output
- Plug-in compatible with industry standard LM1881 in 5V applications
- Available in 8-pin DIP and SO package

Applications

- Video special effects
- Video test equipment
- Video distribution
- Displays
- Imaging
- Video data capture
- Video triggers

Demo Board

A dedicated demo board is not available. However, this device can be placed on the EL4584/5 demo board.

Pinout

EL1882C
(8-PIN PDIP, SO)
TOP VIEW

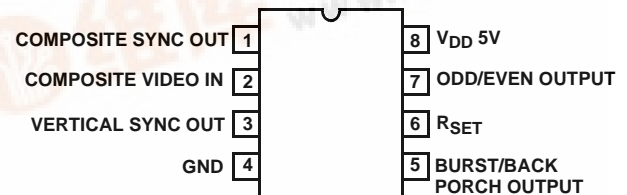

EL1882C

Absolute Maximum Ratings (T_A = 25°C)

V _{CC} Supply 7V	Operating Ambient Temperature Range -40°C to +85°C
Storage Temperature. -65°C to +150°C	Operating Junction Temperature. 125°C
Lead Temperature (5 sec) 260°C	Power Dissipation 400mW
Pin Voltages. -0.5V to V _{CC} +0.5V	

CAUTION: Stresses above those listed in "Absolute Maximum Ratings" may cause permanent damage to the device. This is a stress only rating and operation of the device at these or any other conditions above those indicated in the operational sections of this specification is not implied.

IMPORTANT NOTE: All parameters having Min/Max specifications are guaranteed. Typical values are for information purposes only. Unless otherwise noted, all tests are at the specified temperature and are pulsed tests, therefore: T_J = T_C = T_A

DC Electrical Specifications V_{DD} = 5V, T_A = 25°C, R_{SET} = 680kΩ, unless otherwise specified.

PARAMETER	DESCRIPTION	MIN	TYP	MAX	UNIT
I _{DD} , Quiescent	V _{DD} = 5V	0.75	1.5	3.0	mA
Clamp Voltage	Pin 2, Unloaded	1.35	1.5	1.65	V
Clamp Discharge Current	Pin 2 = 2V	3.2	12	16	μA
Clamp Charge Current	Pin 2 = 1V	-2.0	-1.5	-0.8	mA
R _{SET} Pin Reference Voltage	Pin 6	1.20	1.31	1.40	V
V _{OL} Output Low Voltage	I _{OL} = 1.6mA		0.4	0.8	V
V _{OH} Output High Voltage	I _{OH} = -40μA	4	4.8		V
	I _{OH} = -1.6mA	2.4	3.5		

Dynamic Specifications

PARAMETER	DESCRIPTION	MIN	TYP	MAX	UNIT
Comp Sync Prop Delay, t _{CS}	See Figure 2	10	25	40	ns
Vertical Sync Width, t _{VS}	Normal or Default Trigger, 50%-50%	190	270	350	μs
Vertical Sync Default Delay, t _{VSD}	See Figure 3	35	65	85	μs
Burst/Back Porch Delay, t _{BD}	See Figure 2	250	450	650	ns
Burst/Back Porch Width, t _B	See Figure 2	2.5	3.6	4.5	μs
Input Dynamic Range	Video Input Amplitude to Maintain 50% Slice Spec	0.5		2	V _{P-P}
Slice Level	V _{SLICE} /V _{CLAMP}	40	50	60	%

EL1882C

Pin Descriptions

PIN NUMBER	PIN NAME	FUNCTION
1	Composite Sync Out	Composite sync pulse output; sync pulses start on a falling edge and end on a rising edge.
2	Composite Video In	AC coupled composite video input; sync tip must be at the lowest potential (positive picture phase).
3	Vertical Sync Out	Vertical sync pulse output; the falling edge of vert sync is the start of the vertical period.
4	GND	Supply ground.
5	Burst/Back Porch Output	Burst/back porch output; low during burst portion of composite video.
6	R _{SET} (Note 1)	An external resistor to ground sets all internal timing; a 681k 1% resistor will provide correct timing for NTSC signals.
7	Odd/Even Output	Odd/even field output; high during odd fields, low during even fields; transitions occur at start of vert sync pulse.
8	V _{DD} 5V	Positive supply (5V).

NOTE:

1. R_{SET} must be a 1% resistor.

Typical Performance Curves

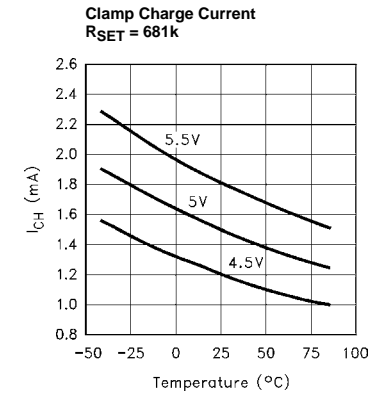
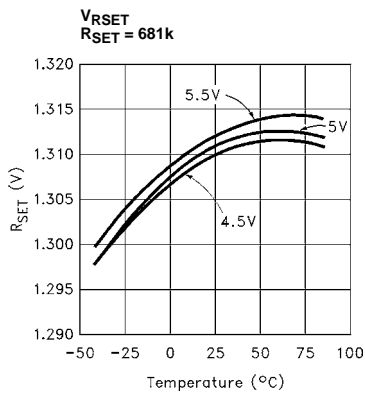
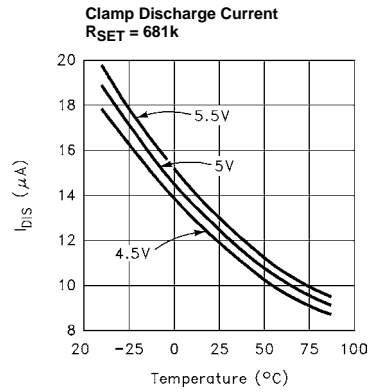
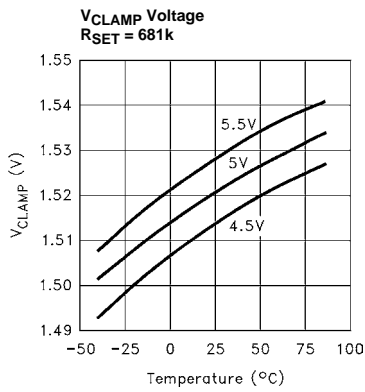
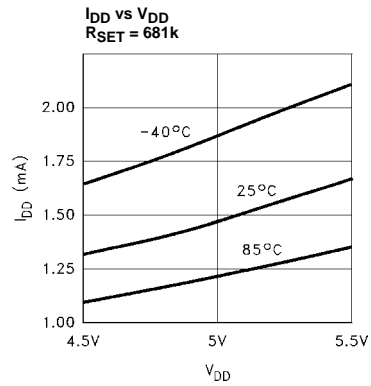
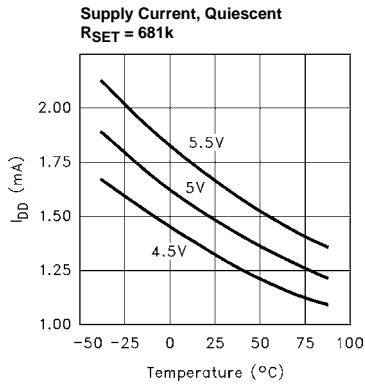

EL1882C

Typical Performance Curves (Continued)

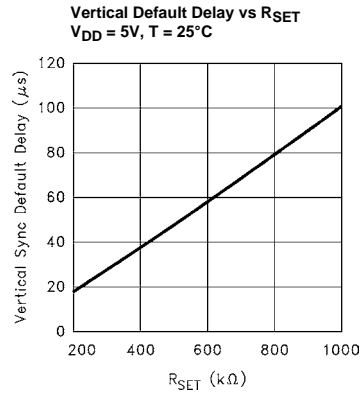
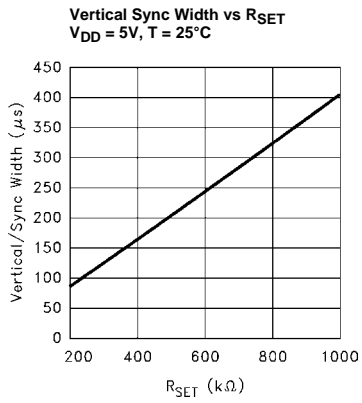
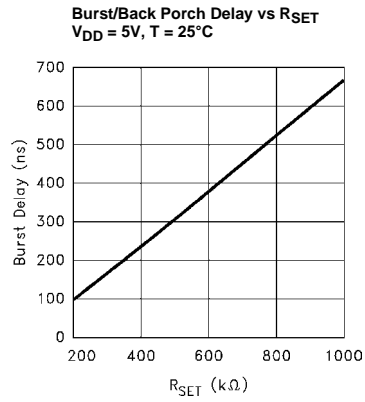
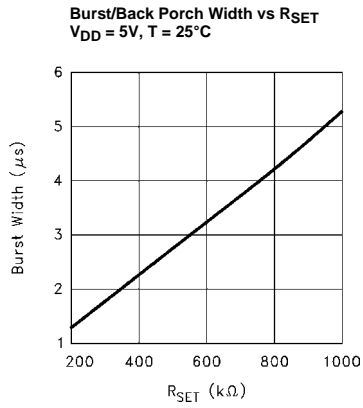
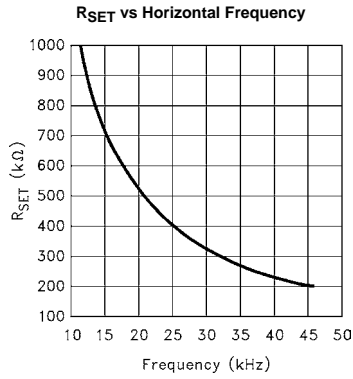

EL1882C

Typical Performance Curves (Continued)

Composite Sync Prop Delay
RSET = 681k, VDD = 5V

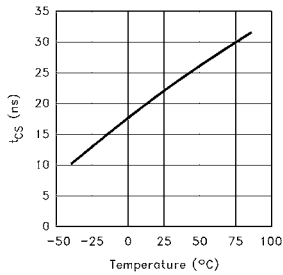

Burst/Back Porch Width,
RSET = 681k

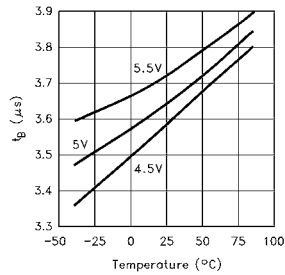

Burst/Back Porch Delay Time,
RSET = 681k

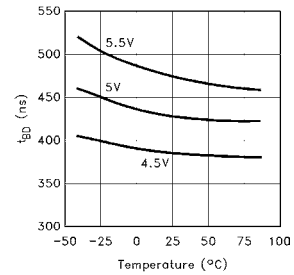

Vertical Sync Pulse Width
RSET = 681k

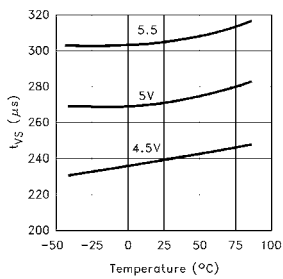

Vertical Sync Default Delay Time,
RSET = 681k

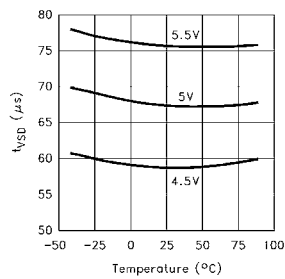

Composite Sync vs Delay Time
RSET = 681k

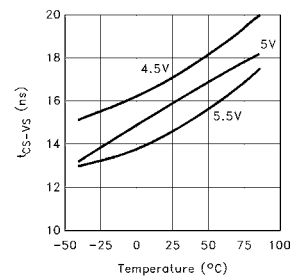

Composite Sync to
Odd/Even Delay Time
RSET = 681k

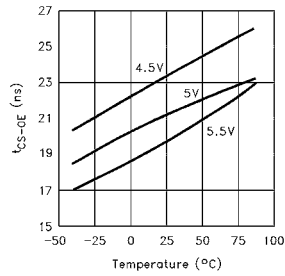

Timing Diagrams

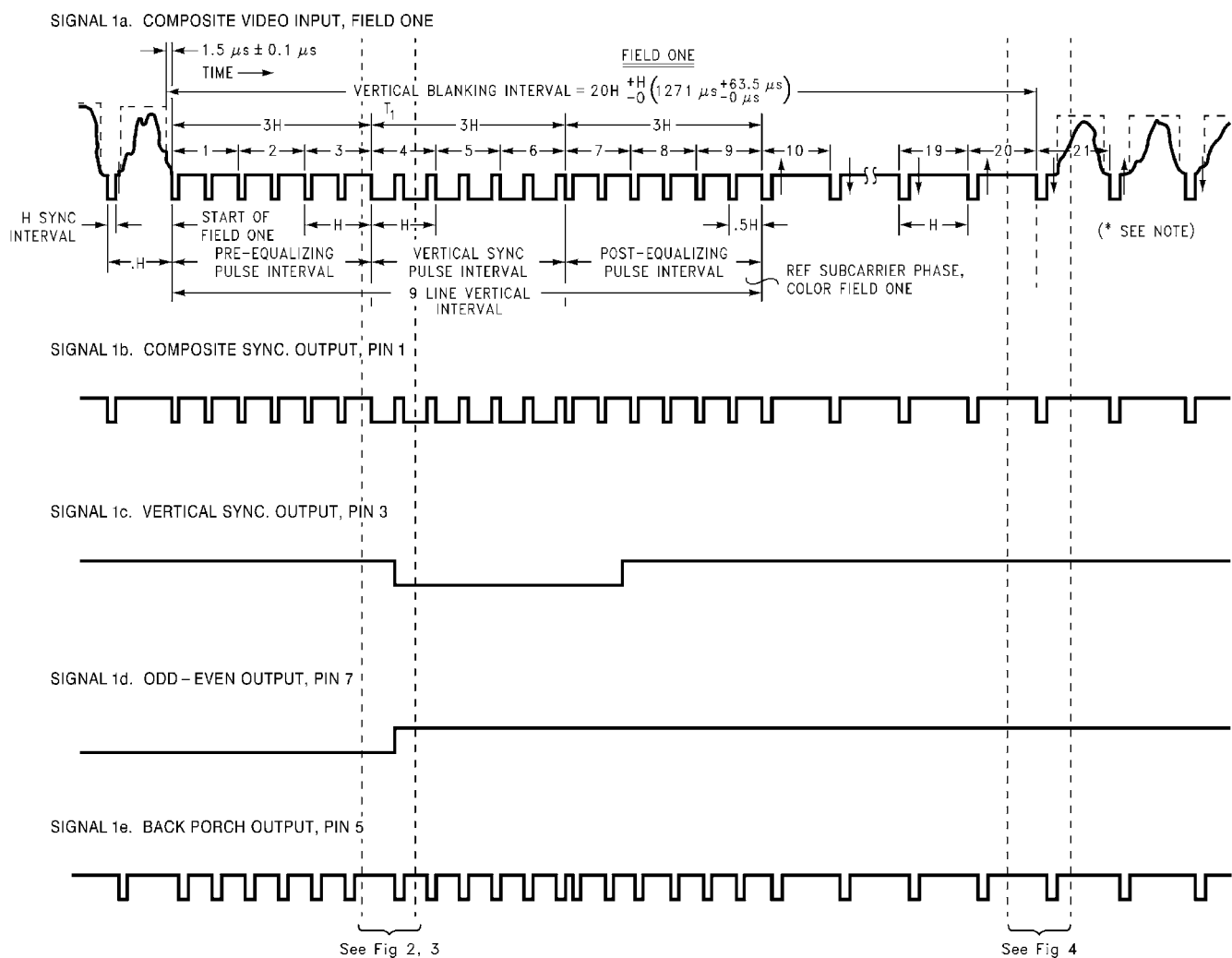

NOTES:

- b. The composite sync output reproduces all the video input sync pulses, with a propagation delay.
- c. Vertical sync leading edge is coincident with the first vertical serration pulse leading edge, with a propagation delay.
- d. Odd-even output is low for even field, and high for odd field.
- e. Back porch goes low for a fixed pulse width on the trailing edge of video input sync pulses. Note that for serration pulses during vertical, the back porch starts on the rising edge of the serration pulse (with propagation delay).

* Signal 1a drawing reproduced with permission from EIA.

FIGURE 1. STANDARD (NTSC INPUT) TIMING

Expanded Timing Diagrams

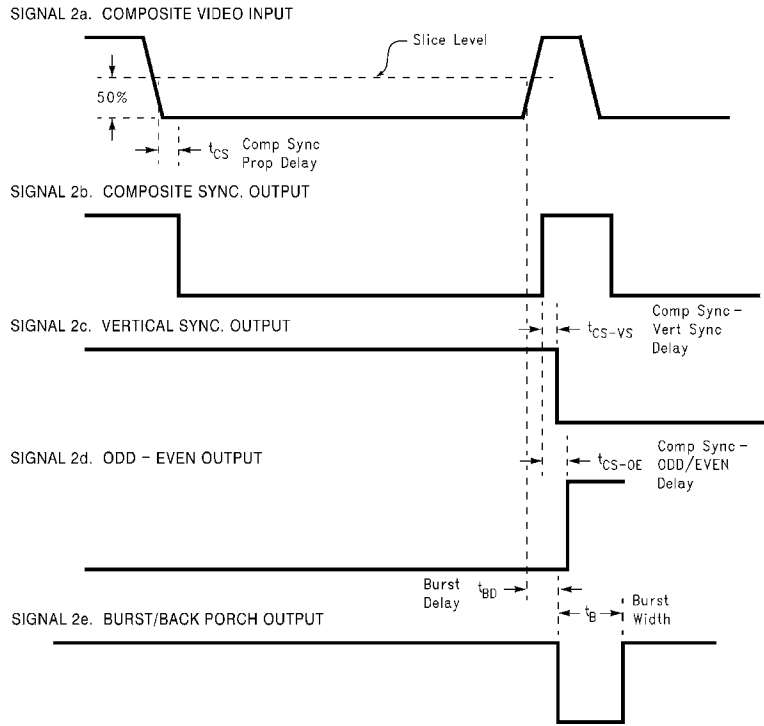

FIGURE 2. STANDARD VERTICAL TIMING

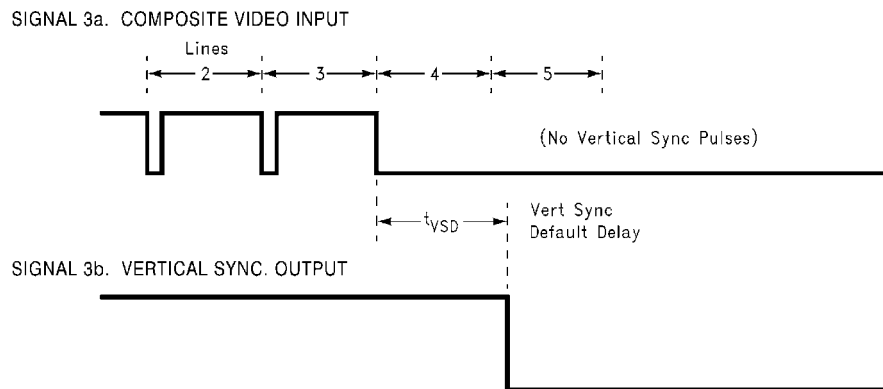

FIGURE 3. NON-STANDARD VERTICAL TIMING

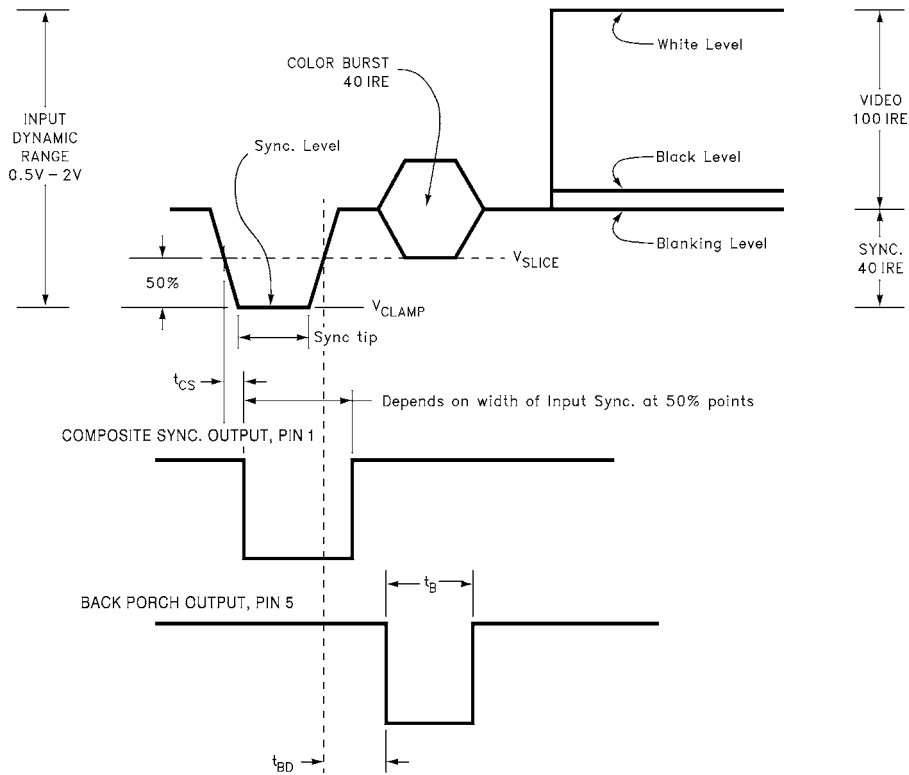

FIGURE 4. STANDARD (NTSC INPUT) H. SYNC DETAIL

Applications Information

Video In

A simplified block diagram is shown in Figure 6.

An AC coupled video signal is input to **Video In** pin 2 via C_1 , nominally $0.1\mu\text{F}$. Clamp charge current will prevent the signal on pin 2 from going any more negative than Sync Tip Ref, about 1.5V . This charge current is nominally about 1mA . A clamp discharge current of about $10\mu\text{A}$ is always attempting to discharge C_1 to Sync Tip Ref, thus charge is lost between sync pulses that must be replaced during sync pulses. The droop voltage that will occur can be calculated from $IT = CV$, where V is the droop voltage, I is the discharge current, T is the time between sync pulses (sync period - sync tip width), and C is C_1 .

An NTSC video signal has a horizontal frequency of 15.73kHz , and a sync tip width of $4.7\mu\text{s}$. This gives a period of $63.6\mu\text{s}$ and a time $T = 58.9\mu\text{s}$. The droop voltage will then be $V = 5.9\text{mV}$. This is less than 2% of a nominal sync tip amplitude of 286mV . The charge represented by this droop is replaced in a time given by $T = CV/I$, where I = clamp charge current = 1mA . Here $T = 590\text{ns}$, about 12% of the sync pulse width of $4.7\mu\text{s}$. It is important to choose C_1 large enough so that the droop voltage does not approach the 50% switching threshold of the internal comparator.

AGC and Composite Sync

The clamped video signal then passes to the AGC, which will maintain the blanking level of its output (sensed during burst) at the blanking reference level. The AGC should therefore present a constant amplitude signal to the comparator, if the input is within the AGC's dynamic range. A 50% slicing reference is compared with the AGC's output at the comp circuit. Comp's output is level shifted and buffered to TTL levels, and sent out as **Comp Sync** on pin 1.

Burst

A low-going Burst pulse follows each rising edge of sync, and lasts approximately $3.5\mu\text{s}$ for an R_{SET} of $681\text{k}\Omega$. This signal is used internally to gate the AGC feedback for determining blanking level.

Vertical Sync

A low-going **Vertical Sync** pulse is output during the start of the vertical cycle of the incoming video signal. The vertical cycle starts with a pre-equalizing phase of pulses with a duty cycle of about 93%, followed by a vertical serration phase that has a duty cycle of about 15%. Vertical Sync is clocked out of the EL1882C on the first rising edge during the vertical serration phase. In the absence of vertical serration pulses, a vertical sync pulse will be forced out after the vertical sync

EL1882C

default delay time, approximately $60\mu\text{s}$ after the last falling edge of the vertical equalizing phase for $R_{\text{SET}} = 681\text{k}\Omega$.

Odd/Even

Because a typical television picture is composed of two interlaced fields, there is an odd field that includes all the odd lines, and an even field that consists of the even lines. This odd/even field information is decoded by the EL1882C during the end of picture information and the beginning of vertical information. The odd/even circuit includes a T-flip-flop that is reset during full horizontal lines, but not during half lines or vertical equalization pulses. The T-flip-flop is clocked during each falling edge of these half period pulses. Even fields will toggle until a low state is clocked to the odd/even pin 7 at the beginning of vertical sync, and odd fields will cause a high state to be clocked to the odd/even pin at the start of the next vertical sync pulse. Odd/even can be ignored if using non-interlaced video, as there is no change in timing from one field to the next.

R_{SET}

An external R_{SET} resistor, connected from R_{SET} pin 6 to ground, produces a reference current that is used internally as the timing reference for vertical sync width, vertical sync

default delay, burst gate delay and burst width. Decreasing the value of R_{SET} increases the reference current, which in turn decreases reference times and pulse widths. A higher frequency video input necessitates a lower R_{SET} value.

Chroma Filter

When the EL1882 is used in composite color systems, a chroma filter is required at the video input. This is so because the color burst signal extends to the 50% point of the sync pulse (-20 IRE). Since the EL1882 slices at the 50% level, a chroma filter is required to attenuate the color burst signal to a point above the 50% level. Without this filter false sync triggering may occur during color burst. An example chroma filter is shown in Figure 5. It can be implemented very simply and inexpensively with a series resistor of 620Ω and a parallel capacitor of 500pF , which gives a single pole roll-off frequency of about 500kHz . This sufficiently attenuates the 3.58MHz (NTSC) or 4.43MHz (PAL) color burst signal, yet passes the approximately 15kHz sync signals without appreciable attenuation. A chroma filter will increase the propagation delay from composite sync to outputs.

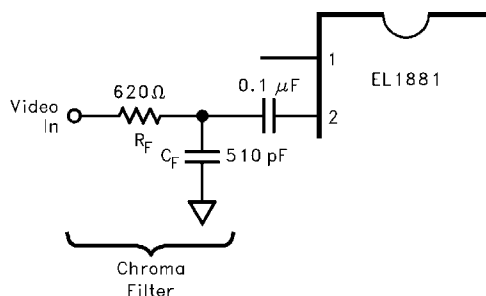

FIGURE 5.

