

élantec
HIGH PERFORMANCE ANALOG INTEGRATED CIRCUITS

EL2009C

90 MHz 1 Amp Buffer Amplifier

EL2009C

Features

- High slew rate—3000 V/ μ s
- Wide bandwidth—
125 MHz @ $R_L = 50\Omega$
90 MHz @ $R_L = 10\Omega$
- Output current—1A continuous
- Output impedance— 1Ω
- Short circuit protected
- Power package with isolated metal tab

Applications

- Video distribution amplifier
- Fast op amp booster
- Flash converter driver
- Motor driver
- Pulse transformer driver
- A.T.E. pin driver

Ordering Information

Part No.	Temp. Range	Package	Outline #
EL2009CT	0°C to +75°C	TO-220	MDP0028

Connection Diagram

5-Pin TO-220

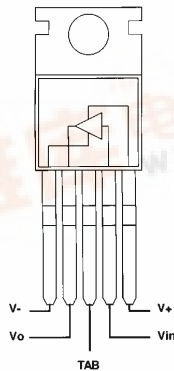

Top View

2009-1

General Description

The EL2009 is a patented high speed bipolar monolithic buffer amplifier designed to provide currents over 1 amp at high frequencies, while drawing 40 mA of quiescent supply current. The EL2009's 3000 V/ μ s slew rate and 90 MHz bandwidth driving a 10 Ω load insures stability in fast op amp feedback loops. Elantec has applied for patents on unique circuitry within the EL2009.

Used as an open loop buffer, the EL2009's low output impedance (1 Ω) gives a gain of 0.99 when driving a 100 Ω load and 0.9 driving a 10 Ω load.

The EL2009 has an output short circuit current limit which will protect the device under both a DC fault condition and AC operation with reactive loads.

The EL2009 is constructed using Elantec's proprietary Complementary Bipolar process that produces PNP and NPN transistors with essentially identical AC and DC characteristics. In the EL2009, the Complementary Bipolar process also insulates the package's metal heat sink tab from all supply voltages. Therefore, the tab may be mounted to an external heat sink or the chassis without an insulator.

The EL2009CT is specified for operation over the 0°C to +75°C temperature range and is provided in a 5-lead TO-220 plastic power package.

Simplified Schematic

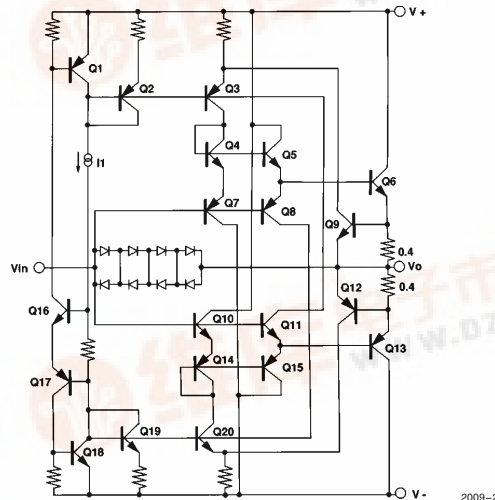

2009-2

Manufactured under U.S. Patent No. 4,833,424 and 4,827,223 and U.K. Patent No. 2217134.

December 1995 Rev C

Note: All information contained in this data sheet has been carefully checked and is believed to be accurate as of the date of publication; however, this data sheet cannot be a "controlled document". Current revisions, if any, to these specifications are maintained at the factory and are available upon your request. We recommend checking the revision level before finalization of your design documentation.



EL2009C

90 MHz 1 Amp Buffer Amplifier

Absolute Maximum Ratings ($T_A = 25^\circ\text{C}$)

V_S	Supply Voltage ($V_+ - V_-$)	$\pm 18\text{V}$ or 36V	T_A	Operating Temperature Range	0°C to $+75^\circ\text{C}$
V_{IN}	Input Voltage (Note 1)	$\pm 15\text{V}$ or V_S	T_J	Operating Junction Temp.	175°C
I_{IN}	Input Current (Note 1)	$\pm 50\text{ mA}$	T_{ST}	Storage Temp. Range	-65°C to $+150^\circ\text{C}$
P_D	Power Dissipation (Note 2)	See Curves	T_{LD}	Lead Solder Temp. < 10 seconds	300°C

Important Note:

All parameters having Min/Max specifications are guaranteed. The Test Level column indicates the specific device testing actually performed during production and Quality inspection. Elantec performs most electrical tests using modern high-speed automatic test equipment, specifically the LTX77 Series system. Unless otherwise noted, all tests are pulsed tests, therefore $T_J = T_C = T_A$.

Test Level	Test Procedure
I	100% production tested and QA sample tested per QA test plan QCX0002.
II	100% production tested at $T_A = 25^\circ\text{C}$ and QA sample tested at $T_A = 25^\circ\text{C}$, T_{MAX} and T_{MIN} per QA test plan QCX0002.
III	QA sample tested per QA test plan QCX0002.
IV	Parameter is guaranteed (but not tested) by Design and Characterization Data.
V	Parameter is typical value at $T_A = 25^\circ\text{C}$ for information purposes only.

Electrical Characteristics $V_S = \pm 15\text{V}$, $R_S = 50\Omega$, unless otherwise specified

Parameter	Description	Test Conditions			Limits			Test Level	Units
		V_{IN}	Load	Temp	Min	Typ	Max		
V_{OS}	Output Offset Voltage	0	∞	25°C	-60		60	I	mV
				T_{MIN}, T_{MAX}	-80		80	IV	mV
I_{IN}	Input Current	0	∞	25°C	-125	-5	125	I	μA
				T_{MIN}, T_{MAX}	-200		200	IV	μA
R_{IN}	Input Impedance	$\pm 12\text{V}$	100Ω	25°C	250	900		I	$\text{k}\Omega$
A_{V1}	Voltage Gain	$\pm 10\text{V}$	∞	25°C	0.985	0.999		I	V/V
A_{V2}	Voltage Gain	$\pm 10\text{V}$	10Ω	25°C	0.88	0.90		I	V/V
A_{V3}	Voltage Gain, $V_S = \pm 5\text{V}$	$\pm 3\text{V}$	10Ω	25°C	0.87	0.89		I	V/V
V_{O1}	Output Voltage Swing	$\pm 14\text{V}$	100Ω	25°C	± 13			I	V
V_{O2}	Output Voltage Swing	$\pm 12\text{V}$	10Ω	25°C	± 10.5	± 11		I	V
R_{O1}	Output Impedance	$\pm 10\text{V}$	$\pm 10\text{ mA}$	25°C			1.5	I	Ω
R_{O2}	Output Impedance	$\pm 10\text{V}$	$\pm 1\text{A}$	25°C		0.9	1.0	I	Ω
I_O	Output Current	$\pm 12\text{V}$	(Note 3)	25°C	1.4	1.8		I	A
				T_{MIN}, T_{MAX}	1			IV	A
I_S	Supply Current	0	∞	25°C	30	45	65	I	mA
PSRR	Supply Rejection (Note 4)	0	∞	25°C	60			I	dB

EL2009C

90 MHz 1 Amp Buffer Amplifier

Electrical Characteristics $V_S = \pm 15V, R_S = 50\Omega$, unless otherwise specified — Contd.

Parameter	Description	Test Conditions			Limits			Test Level	Units
		V_{IN}	Load	Temp	Min	Typ	Max		
$V_S +, V_S -$	Supply Sensitivity (Note 5)		∞	25°C			2	I	mV/V
SR_1	Slew Rate (Note 6)	$\pm 10V$	50 Ω 10 Ω	25°C		3000 2500		V	V/ μs
SR_2	Slew Rate (Note 7)	$\pm 5V$	10 Ω	25°C		1250		V	V/ μs
t_r, t_f	Rise/Fall Time	100 mV	10 Ω	25°C		7		V	ns
BW	-3 dB Bandwidth	100 mV	10 Ω	25°C		90		V	MHz
C_{IN}	Input Capacitance			25°C		25		V	pF
THD	Total Harmonic Distortion			25°C			1	I	%

Note 1: If the input exceeds the ratings shown (or the supplies) or if the input voltage exceeds $\pm 7.5V$ then the input current must be limited to ± 50 mA.

Note 2: The maximum power dissipation depends on package type, ambient temperature and heat sinking. See the characteristic curves for more details.

Note 3: Force the input to +12V and the output to +10V and measure the output current. Repeat with -12V input and -10V on the output.

Note 4: $V_S = \pm 4.5V$ then V_S is changed to $\pm 18V$.

Note 5: $V_S + = +15V, V_S - = 4.5V$ then $V_S -$ is changed to -18V and $V_S + = -15V, V_S - = +4.5V$ then $V_S +$ is changed to +18V.

Note 6: Slew Rate is measured between $V_{OUT} = +5V$ and $-5V$.

Note 7: Slew Rate is measured between $V_{OUT} = +2.5V$ and $-2.5V$.

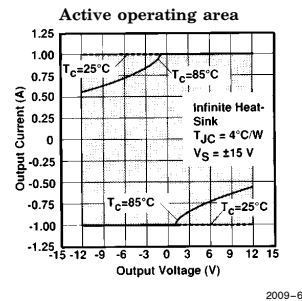
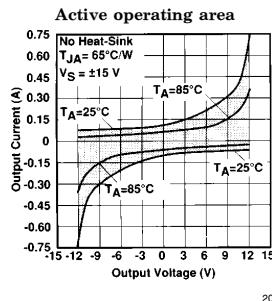
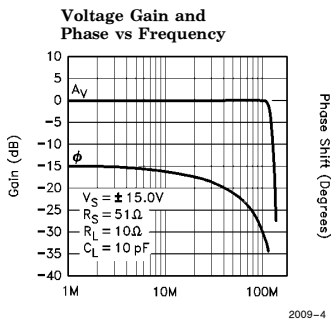

Applications Information

The EL2009 is a higher bandwidth of the EL2008. It is recommended that you read the EL2008 application section.

Video Distribution Amplifier

The EL2009 can drive 15 double matched 75 Ω cables. If the EL2009 is used within an op amp feedback loop the output levels are independent of loading. The circuit below accepts 1 of 2 inputs

and drives 15 cables. Pin 8 of the EL2020 (Disable) is used to multiplex between the inputs and can be easily expanded to accept more inputs. The circuit as shown when fully loaded has differential phase $< 0.1^\circ$ and differential gain $< 0.1\%$. The 100 Ω resistor at the EL2009 input (R_1) is necessary to stabilize the loop. The EL2009 operates with a CLASS AB output which exhibits a slight rise in output impedance when-

EL2009C

90 MHz 1 Amp Buffer Amplifier

Applications Information — Contd.
 ever the current it sources into the load approaches zero. In those cases, where differential gain and phase are measurably affected, resistor R2 may be added to ensure that the EL2009 out-

put current never reaches zero. This will result in a CLASS A output stage with active pulldown but with the penalty of power dissipation in R2. More information about driving cables can be found in the EL2003 data sheet.

Video Mux and Distribution Amp.

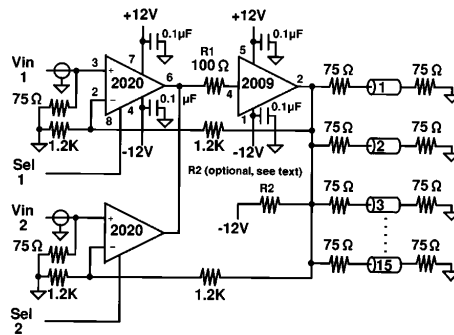

2009-3

EL2009C

90 MHz 1 Amp Buffer Amplifier

EL2009 Macromodel

```

* Connections:      + input
*                  |
*                  | + Vsupply
*                  | |
*                  | | - Vsupply
*                  | |
*                  | | output
*                  | |
.subckt M2009      4   5   1   2
*
* Input Stage
*
e1 10 0 4 0 1.0
r1 10 0 1K
rh 10 11 1K
ch 11 0 1pF
rc 11 12 6.3K
cc 12 0 0.159pF
e2 13 0 12 0 1.0
*
* Output Stage
*
q1 1 13 14 qp
q2 5 13 15 qn
q3 5 14 16 qn 10
q4 1 15 19 qp 10
r2 16 2 0.2
r3 19 2 0.2
c1 14 0 1.7pF
c1 15 0 1.7pF
i1 5 14 5mA
i2 15 1 5mA
*
* Bias Current
*
iin + 4 0 5μA
*
* Models
*
.model qn npn (is = 5e-15 bf = 500)
.model qp pnp (is = 5e-15 bf = 500)
*
.ends

```

BLANK

BLANK

EL2009C

90 MHz 1 Amp Buffer Amplifier

Package Outline

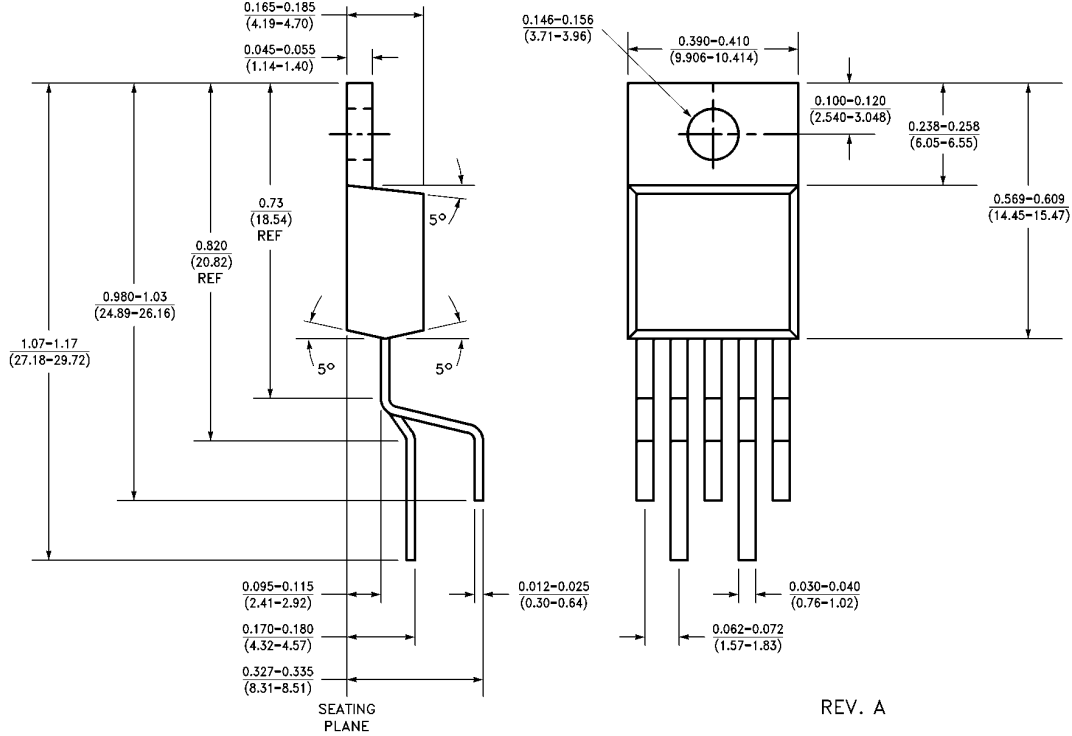

MDP0028 Rev. A
5-Pin TO-220 Package

General Disclaimer

Specifications contained in this data sheet are in effect as of the publication date shown. Elantec, Inc. reserves the right to make changes in the circuitry or specifications contained herein at any time without notice. Elantec, Inc. assumes no responsibility for the use of any circuits described herein and makes no representations that they are free from patent infringement.



Elantec, Inc.
1996 Tarob Court
Milpitas, CA 95035
Telephone: (408) 945-1323
(800) 333-6314
Fax: (408) 945-9305
European Office: 44-71-482-4596

WARNING — Life Support Policy

Elantec, Inc. products are not authorized for and should not be used within Life Support Systems without the specific written consent of Elantec, Inc. Life Support systems are equipment intended to support or sustain life and whose failure to perform when properly used in accordance with instructions provided can be reasonably expected to result in significant personal injury or death. Users contemplating application of Elantec, Inc. products in Life Support Systems are requested to contact Elantec, Inc. factory headquarters to establish suitable terms & conditions for these applications. Elantec, Inc.'s warranty is limited to replacement of defective components and does not cover injury to persons or property or other consequential damages.