

élantec
HIGH PERFORMANCE ANALOG INTEGRATED CIRCUITS

EL4585C
Horizontal Genlock, 8 F_{SC}

EL4585C

Features

- 36 MHz, general purpose PLL
- 8 F_{SC} timing. (Use the EL4584 for 4 F_{SC})
- Compatible with EL4583C Sync Separator
- VCXO, Xtal, or LC tank oscillator
- < 2nS jitter (VCXO)
- User-controlled PLL capture and lock
- Compatible with NTSC and PAL TV formats
- 8 pre-programmed popular TV scan rate clock divisors
- Single 5V, low current operation

Applications

- Pixel Clock regeneration
- Video compression engine (MPEG) clock generator
- Video Capture or digitization
- PIP (Picture In Picture) timing generator
- Text or Graphics overlay timing

Ordering Information

Part No.	Temp. Range	Package	Outline #
EL4585CN	-40°C to +85°C	16-Pin DIP	MDP0031
EL4585CS	-40°C to +85°C	16-Lead SO	MDP0027

For 3F_{sc} and 4F_{sc} clock frequency operation, see EL4584 datasheet.

Demo Board

A demo PCB is available for this product. Request "EL4584/5 Demo Board".

General Description

The EL4585C is a PLL (Phase Lock Loop) sub system, designed for video applications, but also suitable for general purpose use up to 36 MHz. In a video application this device generates a TTL/CMOS compatible Pixel Clock (Clk Out) which is a multiple of the TV Horizontal scan rate, and phase locked to it.

The reference signal is a horizontal sync signal, TTL/CMOS format, which can be easily derived from an analog composite video signal with the EL4583 Sync Separator. An input signal to "coast" is provided for applications where periodic disturbances are present in the reference video timing such as VTR head switching. The Lock detector output indicates correct lock.

The divider ratio is four ratios for NTSC and four similar ratios for the PAL video timing standards, by external selection of three control pins. These four ratios have been selected for common video applications including 8 F_{SC}, 6 F_{SC}, 27 MHz (CCIR 601 format) and square picture elements used in some workstation graphics. To generate 4 F_{SC}, 3 F_{SC}, 13.5 MHz (CCIR 601 format) etc., use the EL4584, which does not have the additional divide by 2 stage of the EL4585.

For applications where these frequencies are inappropriate or for general purpose PLL applications the internal divider can be by passed and an external divider chain used.

FREQUENCIES and DIVISORS

Function	6F _{sc}	CCIR 601	Square	8F _{sc}
Divisor*	1702	1728	1888	2270
PAL Fosc (MHz)	26.602	27.0	29.5	35.468
Divisor*	1364	1716	1560	1820
NTSC Fosc (MHz)	21.476	27.0	24.546	28.636

CCIR 601 divisors yield 1440 pixels in the active portion of each line for NTSC and PAL. Square pixels format gives 640 pixels for NTSC and 768 pixels for PAL.

6F_{sc} frequencies do not yield integer divisors.

*Divisor does not include ÷ 2 block.

Connection Diagram

EL4585 SO, P-DIP Packages

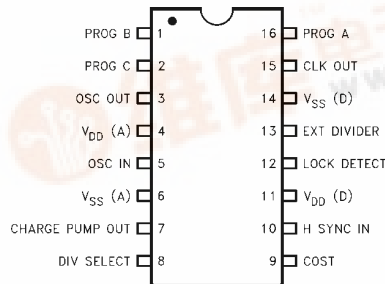

4585-17

March 1996 Rev C

Note: All information contained in this data sheet has been carefully checked and is believed to be accurate as of the date of publication; however, this data sheet cannot be a "controlled document". Current revisions, if any, to these specifications are maintained at the factory and are available upon your request. We recommend checking the revision level before finalization of your design documentation. #4585C



EL4585C

Horizontal Genlock, 8 F_{SC}

Absolute Maximum Ratings (T_A = 25°C)

V _{CC} Supply	7V	Operating Junction Temp	125°C
Storage Temperature	-65°C to +150°C	Power Dissipation	400mW
Lead Temperature	260°C	Oscillator Frequency	36MHz
Pin Voltages	-0.5V to V _{CC} + 0.5V		
Operating Ambient Temperature Range	-40°C to +85°C		

Important Note:

All parameters having Min/Max specifications are guaranteed. The Test Level column indicates the specific device testing actually performed during production and Quality inspection. Elantec performs most electrical tests using modern high-speed automatic test equipment, specifically the LTX77 Series system. Unless otherwise noted, all tests are pulsed tests, therefore T_J = T_C = T_A.

Test Level	Test Procedure
I	100% production tested and QA sample tested per QA test plan QCX0002.
II	100% production tested at T _A = 25°C and QA sample tested at T _A = 25°C, T _{MAX} and T _{MIN} per QA test plan QCX0002.
III	QA sample tested per QA test plan QCX0002.
IV	Parameter is guaranteed (but not tested) by Design and Characterization Data.
V	Parameter is typical value at T _A = 25°C for information purposes only.

DC Electrical Characteristics (V_{DD} = 5V, T_A = 25°C unless otherwise noted)

Parameter	Conditions	Temp	Min	Typ	Max	Test Level	Units
I _{DD}	V _{DD} = 5V (Note 1)	25°C		2	4	I	mA
V _{IL} Input Low Voltage		25°C			1.5	I	V
V _{IH} Input High Voltage		25°C	3.5			I	V
I _{IL} Input Low Current	All inputs except COAST, V _{in} = 1.5V	25°C	-100			I	nA
I _{IH} Input High Current	All inputs except COAST, V _{in} = 3.5V	25°C			100	I	nA
I _{IL} Input Low Current	COAST pin, V _{in} = 1.5V	25°C	-100	-60		I	μA
I _{IH} Input High Current	COAST pin, V _{in} = 3.5V	25°C		60	100	I	μA
V _{OL} Output Low Voltage	Lock Det, I _{OL} = 1.6mA	25°C			0.4	I	V
V _{OH} Output High Voltage	Lock Det, I _{OH} = -1.6mA	25°C	2.4			I	V
V _{OL} Output Low Voltage	CLK, I _{OL} = 3.2mA	25°C			0.4	I	V
V _{OH} Output High Voltage	CLK, I _{OH} = -3.2mA	25°C	2.4			I	V
V _{OL} Output Low Voltage	OSC Out, I _{OL} = 200μA	25°C			0.4	I	V
V _{OH} Output High Voltage	OSC Out, I _{OH} = -200μA	25°C	2.4			I	V
I _{OL} Output Low Current	Filter Out, V _{OUT} = 2.5V	25°C	200	300		I	μA
I _{OH} Output High Current	Filter Out, V _{OUT} = 2.5V	25°C		-300	-200	I	μA
I _{OL} /I _{OH} Current Ratio	Filter Out, V _{OUT} = 2.5V	25°C	1.05	1.0	0.95	I	
I _{LEAK} Filter Out	Coast Mode, V _{DD} > V _{OUT} > 0V	25°C	-100	±1	100	I	nA

Note 1: All inputs to 0V, COAST floating.

EL4585C

Horizontal Genlock, 8 F_{SC}

AC Electrical Characteristics (V_{DD} = 5V, T_A = 25°C unless otherwise noted)

Parameter	Conditions	Temp	Min	Typ	Max	Test Level	Units
VCO Gain @ 20 MHz	Test circuit 1	25°C		15.5		V	dB
H-sync S/N Ratio	V _{DD} = 5V (Note 2)	25°C	35			V	dB
Jitter	VCXO Oscillator	25°C		1		V	ns
Jitter	LC Oscillator (Typ)	25°C		10		V	ns

Note 2: Noisy video signal input to EL4583C, H-sync input to EL4585C. Test for positive signal lock.

Pin Description

Pin No.	Pin Name	Function
16, 1, 2	Prog A,B,C	Digital inputs to select ÷ N value for internal counter. See table below for values.
3	Osc/VCO Out	Output of internal inverter/oscillator. Connect to external crystal or LC tank VCO circuit.
4	V _{DD} (A)	Analog positive supply for oscillator, PLL circuits.
5	Osc/VCO In	Input from external VCO.
6	V _{SS} (A)	Analog ground for oscillator, PLL circuits.
7	Charge Pump Out	Connect to loop filter. If the H-sync phase is leading or H-sync frequency > CLK ÷ 2N, current is pumped into the filter capacitor to increase VCO frequency. If H-sync phase is lagging or frequency < CLK ÷ 2N, current is pumped out of the filter capacitor to decrease VCO frequency. During coast mode or when locked, charge pump goes to a high impedance state.
8	Div Select	Divide select input. When high, the internal divider is enabled and EXT DIV becomes a test pin, outputting CLK ÷ 2N. When low, the internal divider is disabled and EXT DIV is an input from an external ÷ N.
9	Coast	Tri-state logic input. Low(< 1/3 * V _{CC}) = normal mode, Hi Z (or 1/3 to 2/3 * V _{CC}) = fast lock mode, High(> 2/3 * V _{CC}) = coast mode.
10	H-sync In	Horizontal sync pulse (CMOS level) input.
11	V _{DD} (D)	Positive supply for digital, I/O circuits.
12	Lock Det	Lock Detect output. Low level when PLL is locked. Pulses high when out of lock.
13	Ext Div	External Divide input when DIV SEL is low, internal ÷ 2N output when DIV SEL is high.
14	V _{SS} (D)	Ground for digital, I/O circuits.
15	CLK Out	Buffered output of the VCO.

Table 5. VCO Divisors

Prog A Pin 16	Prog B Pin 1	Prog C Pin 2	Div Value N
0	0	0	1702
0	0	1	1728
0	1	0	1888
0	1	1	2270
1	0	0	1364
1	0	1	1716
1	1	0	1560
1	1	1	1820

EL4585C

Horizontal Genlock, 8 F_{SC}

Timing Diagrams

PLL Locked Condition (Phase Error = 0)

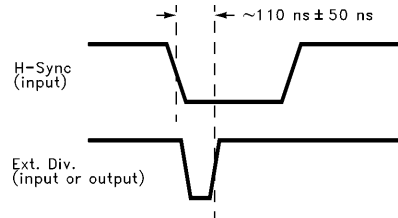

4585-2

Out of Lock Condition

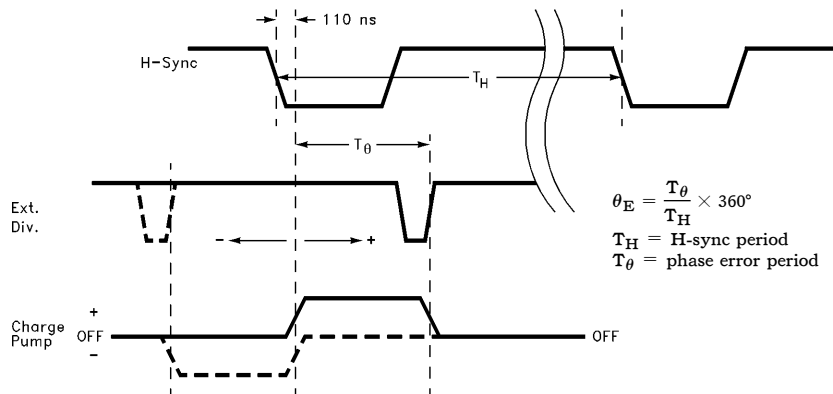

4585-3

Typical Performance Curves

Test Circuit 1

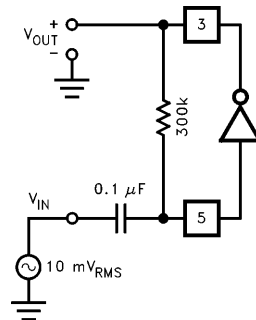

4585-5

EL4585C

Horizontal Genlock, 8 FSC

Typical Performance Curves — Contd.

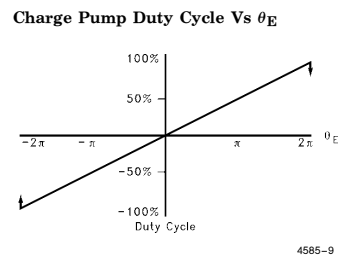
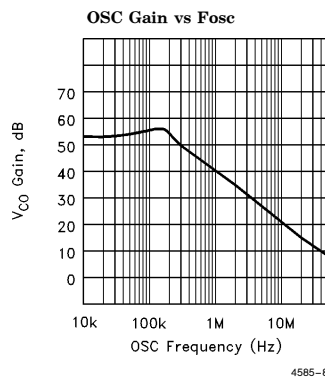
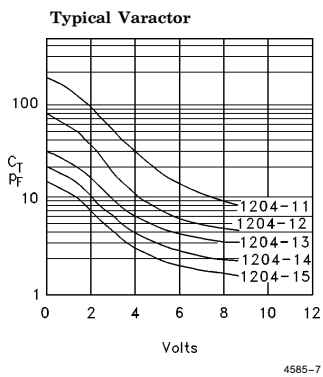
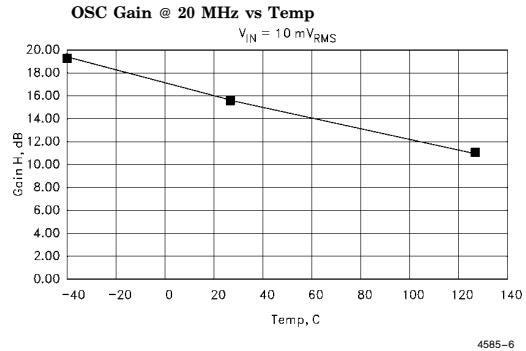
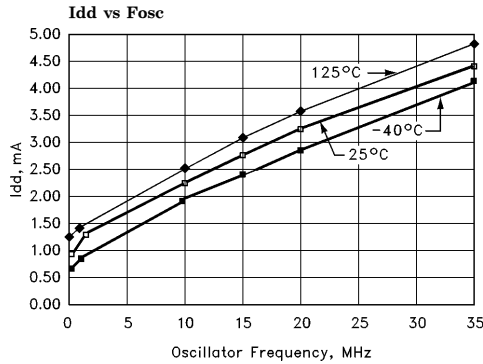

EL4585 Block Diagram

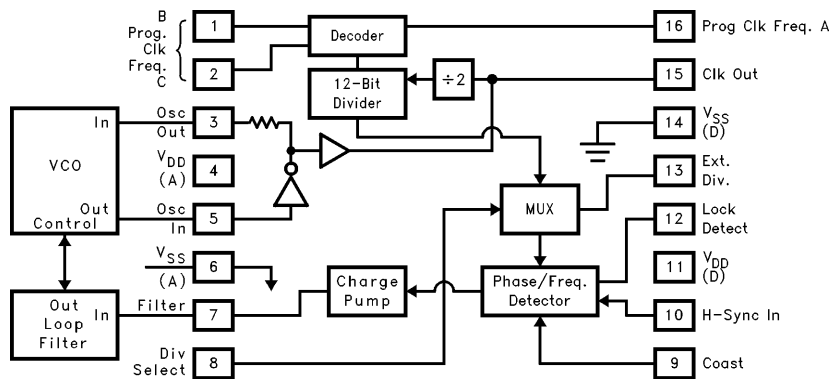

EL4585C

Horizontal Genlock, 8 F_{SC}

Description Of Operation

The horizontal sync signal (CMOS level, falling leading edge) is input to H-SYNC input (pin 10). This signal is delayed about 110nS, the falling edge of which becomes the reference to which the clock output will be locked. (See timing diagrams.) The clock is generated by the signal on pin 5, OSC in. There are 2 general types of VCO that can be used with the EL4585C, LC and crystal controlled. Additionally, each type can be either built up using discrete components, including a varactor as the frequency controlling element, or complete, self contained modules can be purchased with everything inside a metal can. These modules are very forgiving of PCB layout, but cost more than discrete solutions. The VCO or VCXO is used to regulate the clock. An LC tank resonator has greater "pull" than a crystal controlled circuit, but will also be more likely to drift over time, and thus will generate more jitter. The "pullability" of the circuit refers to the ability to pull the frequency of oscillation away from its center frequency by modulating the voltage on the control pin of the VCO module or varactor, and is a function of the slope and range of the capacitance-voltage curve of the varactor or VCO module used. The VCO signal is sent to the CLK out pin, divided by two, then sent to the divide by N counter. The divisor N is determined by the state of pins 1, 2, and 16 and is described in table 5 above. The divided signal is sent, along with the delayed H-sync input, to the phase/frequency detector, which compares the two signals for phase and frequency differences. Any phase difference is converted to a current at the charge pump output, (pin 7). A VCO with a positive frequency deviation with control voltage must be used. Varactors have negative capacitance slope with voltage, resulting in positive frequency deviation with increasing control voltage for the oscillators in figures 10 and 11 below.

VCO

The VCO should be tuned so that its frequency of oscillation is very close to the required clock output frequency when the voltage on the varactor is 2.5 volts. VCXO and VCO modules are already tuned to the desired frequency, so this step is not necessary if using one of these units. The output range of the charge pump output (pin 7) is 0 to

5 volts, and it can source or sink a maximum of about 300 μ A, so all frequency control must be accomplished with variable capacitance from the varactor within this range. Crystal oscillators are more stable than LC oscillators, which translates into lower jitter, but LC oscillators can be pulled from their mid-point values further, resulting in a greater capture and locking range. If the incoming horizontal sync signal is known to be very stable, then a crystal oscillator circuit can be used. If the H-sync signal experiences frequency variations of greater than about 300ppm, an LC oscillator should be considered, as crystal oscillators are very difficult to pull this far. When H-sync input frequency is greater than CLK frequency \div 2N, charge pump output (pin 7) sources current into the filter capacitor, increasing the voltage across the varactor, thus tending to increase VCO frequency. Conversely, charge pump output pulls current from the filter capacitor when H-sync frequency is less than CLK \div 2N, forcing the VCO frequency lower.

Loop Filter

The loop filter controls how fast the VCO will respond to a change in phase comparator output stimulus. Its components should be chosen so that fast lock can be achieved, yet with a minimum of VCO "hunting", preferably in one to two oscillations of charge pump output, assuming the VCO frequency starts within capture range. If the filter is under-damped, the VCO will over and under-shoot the desired operating point many times before a stable lock takes place. It is possible to under-damp the filter so much that the loop itself oscillates, and VCO lock is never achieved. If the filter is over-damped, the VCO response time will be excessive and many cycles will be required for a lock condition. Over-damping is also characterized by an easily unlocked system because the filter can't respond fast enough to perturbations in VCO frequency. A severely over damped system will seem to endlessly oscillate, like a very large mass at the end of a long pendulum. Due to parasitic effects of PCB traces and component variables, it will take some trial and error experimentation to determine the best values to use for any given situation. Use the component tables as a starting point, but be aware that deviations from these values are not out of the ordinary.

EL4585C

Horizontal Genlock, 8 F_{SC}

Description Of Operation — Contd.

External Divide

DIV SEL (pin 8) controls the use of the internal divider. When high, the internal divider is enabled and EXT DIV (pin 13) outputs the CLK out divided by 2N. This is the signal to which the horizontal sync input will lock. When divide select is low, the internal divider output is disabled, and external divide becomes an input from an external divider, so that a divisor other than one of the 8 pre-programmed internal divisors can be used.

Normal Mode

Normal mode is enabled by pulling COAST (pin 9) low (below $\frac{1}{3} * V_{CC}$). If H-SYNC and $CLK \div 2N$ have any phase or frequency difference, an error signal is generated and sent to the charge pump. The charge pump will either force current into or out of the filter capacitor in an attempt to modulate the VCO frequency. Modulation will continue until the phase and frequency of $CLK \div 2N$ exactly match the H-sync input. When the phase and frequency match (with some offset in phase that is a function of the VCO characteristics), the error signal goes to zero, lock detect no longer pulses high, and the charge pump enters a high impedance state. The clock is now locked to the H-sync input. As long as phase and frequency differences remain small, the PLL can adjust the VCO to remain locked and lock detect remains low.

Fast Lock Mode

Fast Lock mode is enabled by either allowing coast to float, or pulling it to mid supply (between $\frac{1}{3}$ and $\frac{2}{3} * V_{CC}$). In this mode, lock is achieved much faster than in normal mode, but the clock divisor is modified on the fly to achieve this. If the phase detector detects an error of enough magnitude, the clock is either inhibited or reset to attempt a "fast lock" of the signals. Forcing the clock to be synchronized to the H-sync input this way allows a lock in approximately 2 H-cycles, but the clock spacing will not

be regular during this time. Once the near lock condition is attained, charge pump output should be very close to its lock-on value, and placing the device into normal mode should result in a normal lock very quickly. Fast lock mode is intended to be used where H-sync becomes irregular, until a stable signal is again obtained.

Coast Mode

Coast mode is enabled by pulling COAST (pin 9) high (above $\frac{2}{3} * V_{CC}$). In coast mode the internal phase detector is disabled and filter out remains in high impedance mode to keep filter out voltage and VCO frequency as constant as possible. VCO frequency will drift as charge leaks from the filter capacitor, and the voltage changes the VCO operating point. Coast mode is intended to be used when noise or signal degradation result in loss of horizontal sync for many cycles. The phase detector will not attempt to adjust to the resultant loss of signal so that when horizontal sync returns, sync lock can be re-established quickly. However, if much VCO drift has occurred, it may take as long to re-lock as when restarting.

Lock Detect

Lock detect (pin 12) will go low when lock is established. Any DC current path from charge pump out will skew EXT DIV relative to H-SYNC in, tending to offset or add to the 110nS internal delay, depending on which way the extra current is flowing. This offset is called static phase error, and is always present in any PLL system. If, when the part stabilizes in a locked mode, lock detect is not low, adding or subtracting from the loop filter series resistor R_2 will change this static phase error to allow LDET to go low while in lock. The goal is to put the rising edge of EXT DIV in sync with the falling edge of H-SYNC + 110nS. (See timing diagrams.) Increasing R_2 decreases phase error, while decreasing R_2 increases phase error. (Phase error is positive when EXT DIV lags H-SYNC.) The resistance needed will depend on VCO design or VCXO module selection.

EL4585C

Horizontal Genlock, 8 F_{SC}

Applications Information

Choosing External Components

1. To choose LC VCO components, first pick the desired operating frequency. For our example we will use 28.636MHz, with an H-sync frequency of 15.734kHz.
2. Choose a reasonable inductor value (1-5μH works well). We choose 3.3μH.
3. Calculate C_T needed to produce F_{OSC}.

$$F_{OSC} = \frac{1}{2\pi \sqrt{LC_T}}$$

$$C_T = \frac{1}{4\pi^2 F^2 L} = \frac{1}{4\pi^2 (28.636e6)^2 (3.3e-6)} = 9.4pF$$

4. From the varactor data sheet find C_V @ 2.5V, the desired lock voltage. C_V = 23pF for our SMV1204-12 for example.
5. C₂ should be about 10C_V, so we choose C₂ = 220pF for our example.
6. Calculate C₁. Since

$$C_T = \frac{C_1 C_2 C_V}{(C_1 C_2) + (C_1 C_V) + (C_2 C_V)}$$

then

$$C_1 = \frac{C_2 C_T C_V}{(C_2 C_V) - (C_2 C_T) - (C_T C_V)}$$

For our example, C₁ = 17pF. (A trim cap may be used for fine tuning.) Examples for each frequency using the internal divider follow.

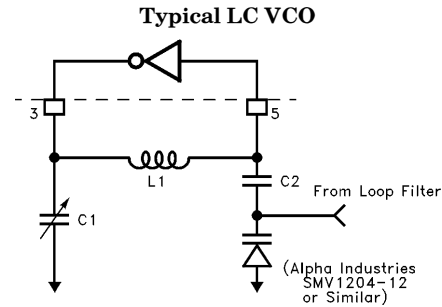

4585-10

LC VCO Component Values (Approximate)

Frequency (MHz)	L1 (μH)	C1 (pF)	C2 (pF)
26.602	3.3	22	220
27.0	3.3	21	220
29.5	2.7	22	220
35.468	2.2	16	220
21.476	4.7	26	220
24.546	3.9	22	220
28.636	3.3	17	220

Note: Use shielded inductors for optimum performance.

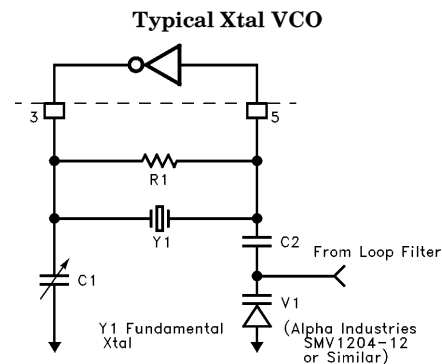

4585-11

EL4585C

Horizontal Genlock, 8 F_{SC}

Typical Application

Horizontal genlock provides clock for an analog to digital converter, digitizing analog video.

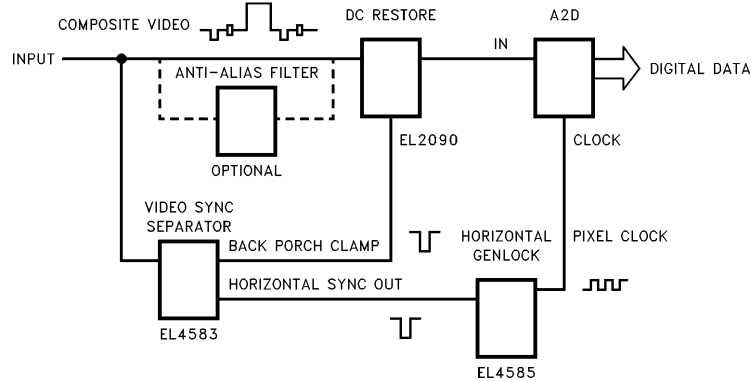

Xtal VCO Component Values (Approximate)

Frequency (MHz)	R1 (kΩ)	C1 (pF)	C2 (μF)
26.602	300	15	.001
27.0	300	15	.001
29.5	300	15	.001
35.468	300	15	.001
21.476	300	15	.001
24.546	300	15	.001
28.636	300	15	.001

The above oscillators are arranged as Colpitts oscillators, and the structure is redrawn here to emphasize the split capacitance used in a Colpitts oscillator. It should be noted that this oscillator configuration is just one of literally hundreds possible, and the configuration shown here does not necessarily represent the best solution for all applications. Crystal manufacturers are very informative sources on the design and use of oscillators in a wide variety of applications, and the reader is encouraged to become familiar with them.

Colpitts Oscillator

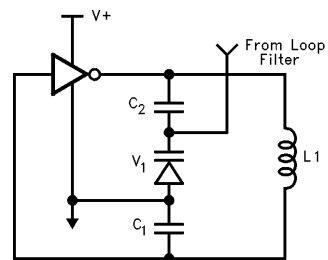

C₁ is to adjust the center frequency, C₂ DC isolates the control from the oscillator, and V₁ is the primary control device. C₂ should be much larger than C_V so that V₁ has maximum modulation capability. The frequency of oscillation is given by:

$$F = \frac{1}{2\pi\sqrt{LC_T}}$$

$$C_T = \frac{C_1 C_2 C_V}{(C_1 C_2) + (C_1 C_V) + (C_2 C_V)}$$

EL4585C

Horizontal Genlock, 8 F_{SC}

Choosing Loop Filter Components

The PLL, VCO, and loop filter can be described as:

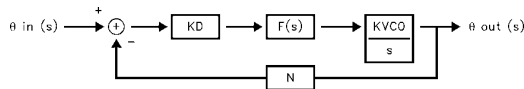

4585-13

Where:

K_d = phase detector gain in A/rad

$F(s)$ = loop filter impedance in V/A

K_{VCO} = VCO gain in rad/s/V

N = Total internal or external divisor (see 3 below)

It can be shown that for the loop filter shown below:

$$C_3 = \frac{K_d K_{VCO}}{N \omega_n^2}, C_4 = \frac{C_3}{10}, R_3 = \frac{2N\zeta\omega_n}{K_d K_{VCO}}$$

Where ω_n = loop filter bandwidth, and ζ = loop filter damping factor.

- $K_d = 300\mu\text{A}/2\pi\text{rad} = 4.77\text{e-}5\text{A/rad}$ for the EL4585C.
- The loop bandwidth should be about H-sync frequency/20, and the damping ratio should be 1 for optimum performance. For our example, $\omega_n = 15.734\text{kHz}/20 = 787\text{ Hz} \approx 5000\text{ rad/S}$.
- $N = 910 \times 2 = 1820$ from table 1.

$$N = \frac{F_{VCO}}{F_{Hsync}} = \frac{28.636\text{M}}{15.73426\text{k}} = 1820 = 910 \times 2$$

- K_{VCO} represents how much the VCO frequency changes for each volt applied at the control pin. It is assumed (but probably isn't) linear about the lock point (2.5V). Its value depends on the VCO configuration and the varactor

transfer function $C_v = F(V_C)$, where V_C is the reverse bias control voltage, and C_V is varactor capacitance. Since $F(V_C)$ is nonlinear, it is probably best to build the VCO and measure K_{VCO} about 2.5V. The results of one such measurement are shown below. The slope of the curve is determined by linear regression techniques and equals K_{VCO} . For our example, $K_{VCO} = 9.06\text{ Mrad/s/V}$.

FOSC vs V_C, LC VCO

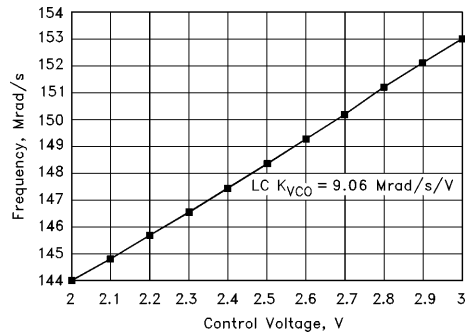

4585-14

- Now we can solve for C_3 , C_4 , and R_3 .

$$C_3 = \frac{K_d K_{VCO}}{N \omega_n^2} = \frac{(4.77\text{e-}5)(9.06\text{e}6)}{(1820)(5000)^2} = 0.01\mu\text{F}$$

$$C_4 = \frac{C_3}{10} = 0.001\mu\text{F}$$

$$R_3 = \frac{2N\zeta\omega_n}{K_d K_{VCO}} = \frac{(2)(1820)(1)(5000)}{(4.77\text{e-}5)(9.06\text{e}6)} = 42.1\text{k}\Omega$$

We choose $R_3 = 43\text{k}\Omega$ for convenience.

- Notice R_2 has little effect on the loop filter design. R_2 should be large, around 100k, and can be adjusted to compensate for any static phase error T_θ at lock, but if made too large, will slow loop response. If R_2 is made smaller, T_θ (see timing diagrams) increases, and if R_2 in-

EL4585C

Horizontal Genlock, 8 F_{SC}

creases, T_θ decreases. For LDET to be low at lock, $|T_\theta| < 50\text{nS}$. C_4 is used mainly to attenuate high frequency noise from the charge pump. The effect these components have on time to lock is illustrated below.

Lock Time

Let $T = R_3 C_3$. As T increases, damping increases, but so does lock time. Decreasing T decreases damping and speeds up loop response, but increases overshoot and thus increases the number of hunting oscillations before lock. Critical damping ($\zeta = 1$) occurs at minimum lock time. Because decreased damping also decreases loop stability, it is sometimes desirable to design slightly overdamped ($\zeta > 1$), trading lock time for increased stability.

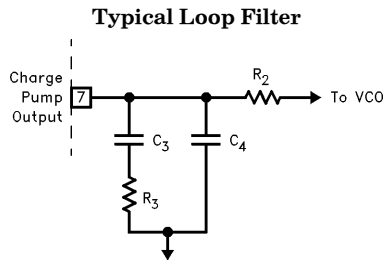

4585-16

LC Loop Filter Components (Approximate)

Frequency (MHz)	R2 (kΩ)	R3 (kΩ)	C3 (μF)	C4 (μF)
26.602	100	39	0.01	0.001
27.0	100	39	0.01	0.001
29.5	100	43	0.01	0.001
35.468	100	51	0.01	0.001
21.476	100	30	0.01	0.001
24.546	100	36	0.01	0.001
28.636	100	43	0.01	0.001

Xtal Loop Filter Components (Approximate)

Frequency (MHz)	R2 (kΩ)	R3 (MΩ)	C3 (pF)	C4 (pF)
26.602	100	4.3	68	6.8
27.0	100	4.3	68	6.8
29.5	100	4.3	68	6.8
35.468	100	4.3	68	6.8
21.476	100	4.3	68	6.8
24.546	100	4.3	68	6.8
28.636	100	4.3	68	6.8

PCB Layout Considerations

It is highly recommended that power and ground planes be used in layout. The oscillator and filter sections constitute a feedback loop and thus care must be taken to avoid any feedback signal influencing the oscillator except at the control input. The entire oscillator/filter section should be surrounded by copper ground to prevent unwanted influences from nearby signals. Use separate paths for analog and digital supplies, keeping the analog (oscillator section) as short and free from spurious signals as possible. Careful attention must be paid to correct bypassing. Keep lead lengths short and place bypass caps as close to the supply pins as possible. If laying out a PCB to use discrete components for the VCO section, care must be taken to avoid parasitic capacitance at the OSC pins 3 and 5, and FILTER out (pin 7). Remove ground and power plane copper above and below these traces to avoid making a capacitive connection to them. It is also recommended to enclose the oscillator section within a shielded cage to reduce external influences on the VCO, as they tend to be very sensitive to "hand waving" influences, the LC variety being more sensitive than crystal controlled oscillators. In general, the higher the operating frequency, the more important these considerations are. Self contained VCXO or VCO modules are already mounted in a shielding cage and therefore do not require as much consideration in layout. Many crystal manufacturers publish informative literature regarding use and layout of oscillators which should be helpful.

EL4585C

Horizontal Genlock, 8 F_{SC}

EL4585/4 Demo Board

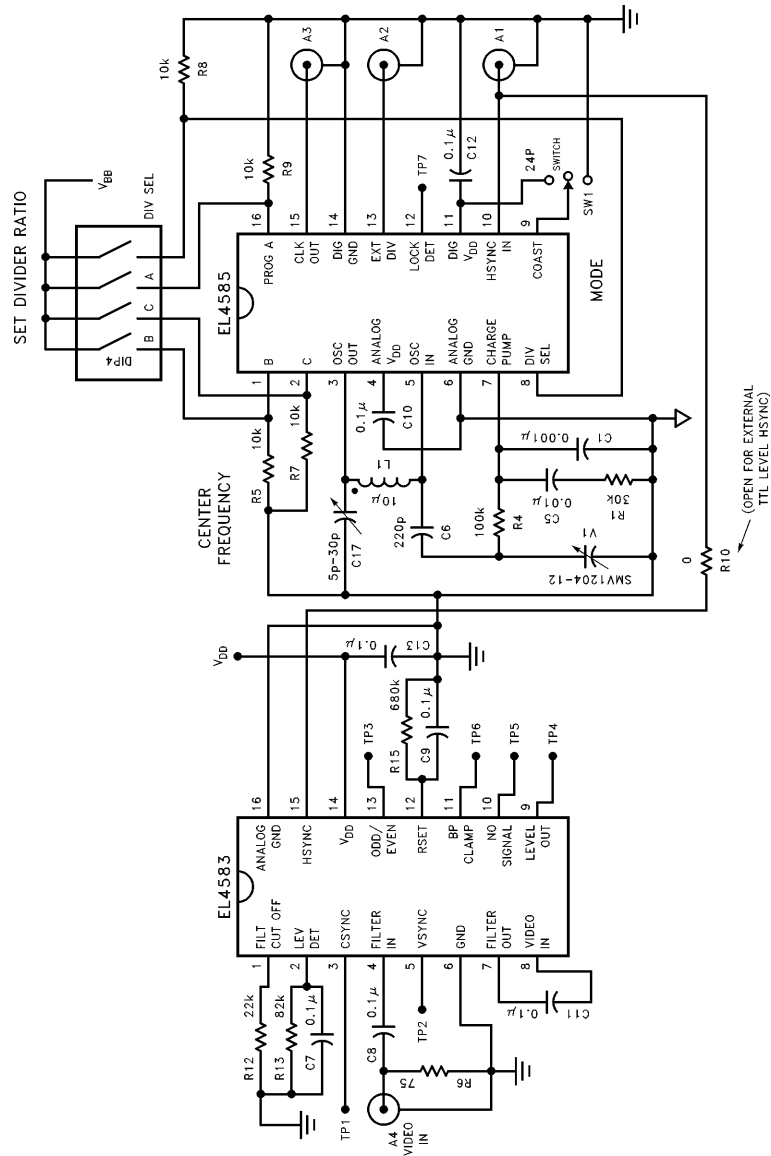

4895-19

EL4585C

Horizontal Genlock, 8 FSC

EL4585/4 Demo Board — Contd.

The VCO and loop filter section of the EL4583/4/5 Demo Board can be implemented in the following configurations:

(1) VCXO

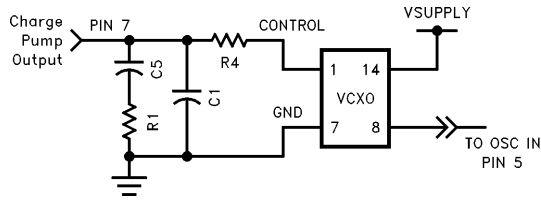

4585-20

(2) XTAL

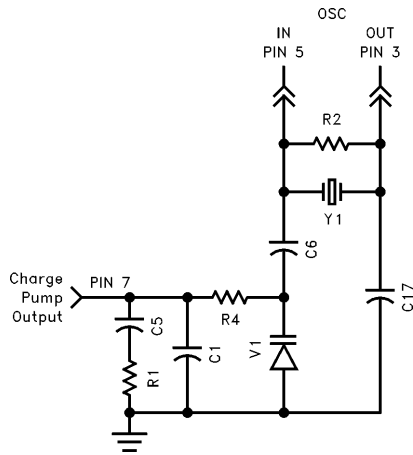

4585-21

(3) LC Tank

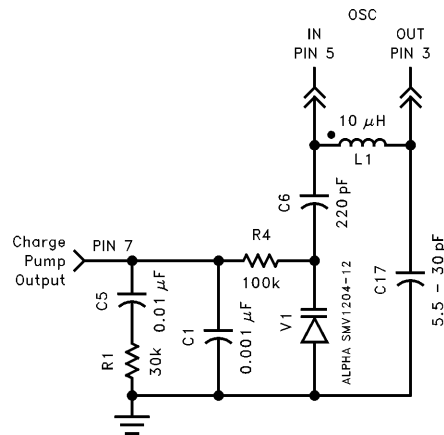

4585-22

BLANK

BLANK

EL4585C

Horizontal Genlock, 8 FSC

Component Sources

Inductors

- Dale Electronics
E. Highway 50
PO Box 180
Yankton, SD 57078-0180
(605) 665-9301

Crystals, VCXO, VCO Modules

- Connor-Winfield
2111 Comprehensive Drive
Aurora, IL 60606
(708) 851-4722
- Piezo Systems
100 K Street
PO Box 619
Carlisle, PA 17013
(717) 249-2151
- Reeves-Hoffman
400 West North Street
Carlisle, PA 17013
(717) 243-5929

- SaRonix
151 Laura Lane
Palo Alto, CA 94043
(415) 856-6900
- Standard Crystal
9940 Baldwin Place
El Monte, CA 91731
(818) 443-2121

Varactors

- Alpha Industries
20 Sylvan Road
Woburn, MA 01801
(617) 935-5150
- Motorola Semiconductor Products
2100 E. Elliot
Tempe, AZ 85284
(602) 244-6900

Note: These sources are provided for information purposes only. No endorsement of these companies is implied by this listing.

General Disclaimer

Specifications contained in this data sheet are in effect as of the publication date shown. Elantec, Inc. reserves the right to make changes in the circuitry or specifications contained herein at any time without notice. Elantec, Inc. assumes no responsibility for the use of any circuits described herein and makes no representations that they are free from patent infringement.

élantec
HIGH PERFORMANCE ANALOG INTEGRATED CIRCUITS

Elantec, Inc.
1996 Tarob Court
Milpitas, CA 95035
Telephone: (408) 945-1323
(800) 333-6314
Fax: (408) 945-9305
European Office: 44-71-482-4596

WARNING — Life Support Policy

Elantec, Inc. products are not authorized for and should not be used within Life Support Systems without the specific written consent of Elantec, Inc. Life Support systems are equipment intended to support or sustain life and whose failure to perform when properly used in accordance with instructions provided can be reasonably expected to result in significant personal injury or death. Users contemplating application of Elantec, Inc. products in Life Support Systems are requested to contact Elantec, Inc. factory headquarters to establish suitable terms & conditions for these applications. Elantec, Inc.'s warranty is limited to replacement of defective components and does not cover injury to persons or property or other consequential damages.