



**Preliminary**

## GENERAL DESCRIPTION

EM57P300 is a tiny-controlled-based voice/dual tone melody/dual tone sound effect Ics which contain all the function of EM57000 series and has an OTP (One Time Programmable) ROM inside.

## FEATURES

- EM57P300 – ROM : 64k x 10 bits (21 sec@6K sample rate).
- Working Voltage 2.4V ~ 5.1V.
- One 4-bit input port, two 4-bit I/O ports, and 32x4 bits RAM.
- 8k (maximum) program ROM.
- One 6-bit timer overflow control.
- ASPCM synthesizer and dual tone melody/sound effect generator.
- 4k~32k Hz playing speed for voice play-back.
- Multiple tempos for dual tone melody/sound effect play-back.
- Variable beats for dual tone melody/sound effect play-back.
- Multiple levels of volume control.
- Fixed current D/A output to drive external connected transistor for voice output.

## PIN DESCRIPTIONS

Pin NO.	I/O	Symbol	Function
1	I	VDD	Positive power supply.
2	O	VO	Voice output.
3	I/O	P3.3	Bit 3 of Port 3.
4	I/O	P3.2	Bit 2 of Port 3.
5	I/O	P3.1	Bit 1 of Port 3.
6		NC	No connect
7	I/O	P3.0	Bit 0 of Port 3.
8	I/O	P2.3	Bit 3 of Port 2.
9	I/O	P2.2	Bit 2 of Port 2.
10	I/O	P2.1/Dout	Bit 1 of Port 2 / Program data output signal
11	I/O	P2.0/Din	Bit 0 of Port 2 / Program data input signal
12	I	P1.3/Din.out.clk/Mode option	Bit 3 of Port 1 / Program control signal
13	I	P1.2/OEB/Mode option	Bit 2 of Port 1 / Program control signal
14	I	P1.1/PGMB/Mode option	Bit 1 of Port 1 / Program control signal
15	I	P1.0/ACLK	Bit 0 of Port 1 / Program control signal
16	I	VSS	Negative power supply.
17	I	OSC	Oscillation component connection pin.
18	I	TEST/Vpp	Test/Programing.



**Preliminary**

**PIN ASSIGNMENT**

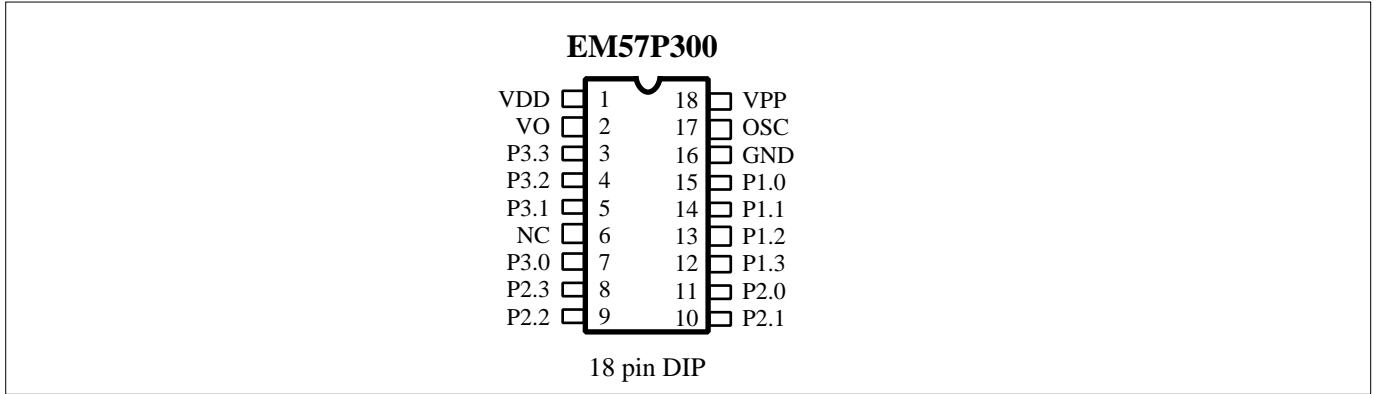

**PROGRAMMING TIMING DIAGRAM**

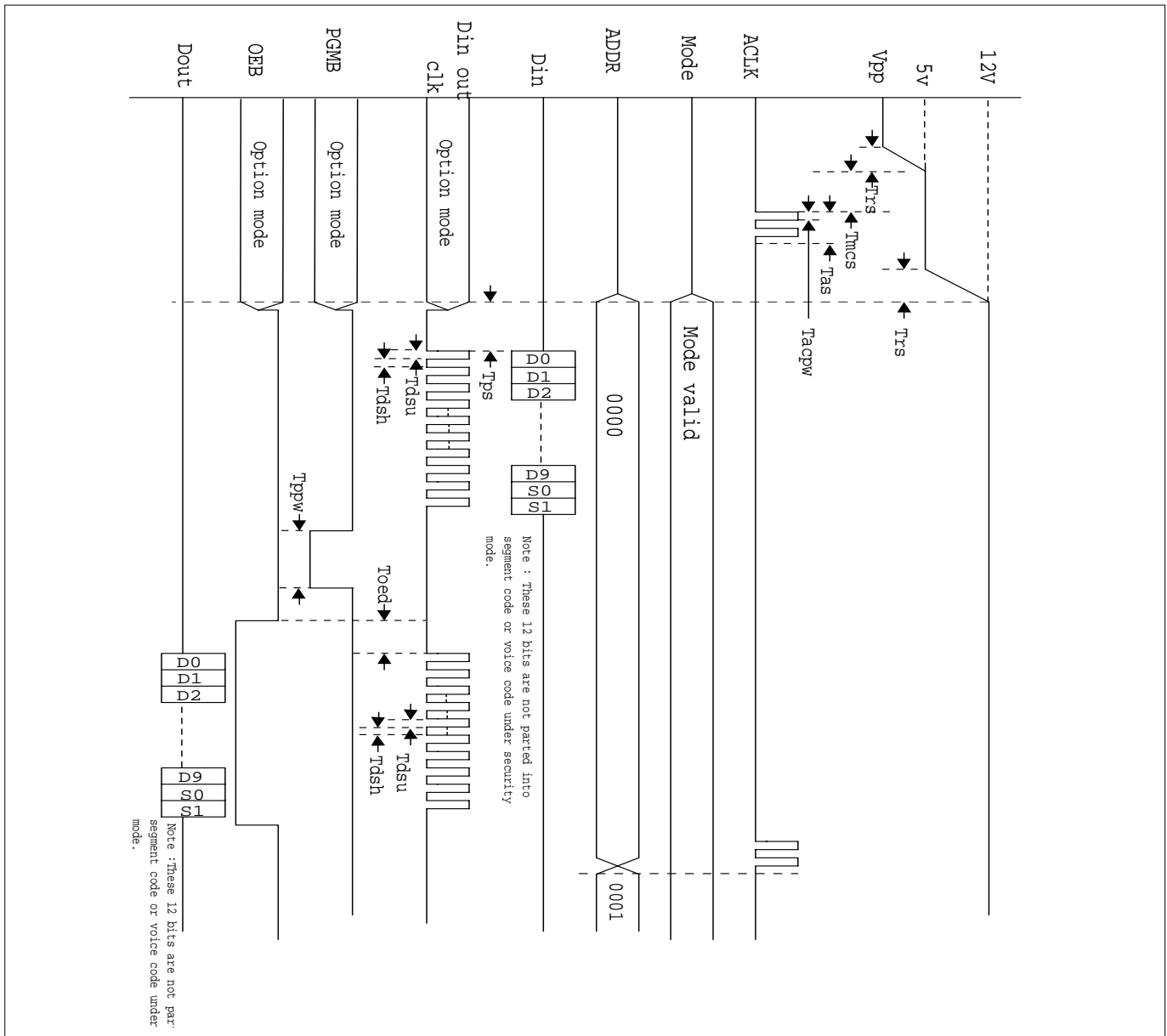



**Preliminary**

**PROGRAMMING MODE**

Mode	P13	P12	P11
Regular	0	0	0
Security	0	0	1

**TIMING PARAMETER**

Symbol	Parameter	Min.	Max.	Unit
Trs	Level set up time	2		us
Tmcs	Mode code setup time	2		us
Tdsu	Data set up time	100		ns
Tdsh	Data hold time	100		ns
Tas	ACLK to byte select time	2		us
Tacpw	Address clock pulse width	2		us
Tppw	Program pulse width	100		us
Tps	Programming mode set up time	4		us
Toed	Output enable setup time	300		ns

Note : Segment ROM S1, S0 is programed just while 5 LSBs of ADDR are all 0.

Programming for security mode :

When programming in security mode, the waveform is just like above. The programming data is as below :

B11 ~ B1	B0
User defined	Security bit

Note : When security = 0, enable security;

When security = 1, disable security.

**DC PROGRAMMING CHARACTERISTICS** ( $V_{DD} = 5V \pm 0.5v$ ,  $V_{PP} = 12.5V \pm 0.5v$ )

Items	Sym.	Min.	Max.	Unit	Test Conditions
Input high voltage	$V_{IH}$	2.2	$V_{DD}+1.0$	V	
Input low voltage	$V_{IL}$	-0.3	0.8	V	
Input current	$I_{IN}$	-	10	$\mu A$	$V_{DD}=5V$ , $V_{IN}=0 \sim V_{DD}$
Output high voltage	$V_{OH}$	2.4	-	V	$I_{OH}=400\mu A$
Output low volatge	$V_{OL}$	-	0.4	V	$I_{OL}=2.1mA$
VDD supply current	$I_{DD}$	-	100	mA	$V_{DD}=5V$
VPP supply current	$I_{PP}$	-	50	mA	$V_{PP}=12.5V$



**Preliminary**

**ABSOLUTE MAXIMUM RATINGS**

Items	Sym.	Min.	Max.	Unit
Supply Voltage	$V_{DD}-V_{SS}$	-0.3	6.0	V
Input Voltage	$V_{IN}$	$V_{SS}-0.3$	$V_{DD}+0.3$	V
Operating Temperature	$T_{OP}$	-20	70	°C
Storage Temperature	$T_{STG}$	-55	+125	°C

**ELECTRICAL CHARACTERISTICS** ( $V_{DD} = 3V, 25^{\circ}C$  unless otherwise specified)

Parameter	Sym.	Min.	Typ.	Max.	Unit	Condition
Operating voltage	$V_{DD}$	2.4	3.0	5.1	V	
Standby current	$I_{DDS}$	-	-	1.0	$\mu A$	$V_{DD}=3V$
Operating current	$I_{DDO}$	-	-	280	$\mu A$	$V_{DD}=3V$ , No load
Drive current of P2,P3	$I_{OD}$	1.0	-	-	mA	$V_{DD}=3V$ , $V_o=2.4V$
Sink current of P2, P3	$I_{OS}$	1.6	-	-	mA	$V_{DD}=3V$ , $V_o=0.4V$
Output current of VO	$I_{VO}$	2.0	3.0	4.0	mA	$V_{DD}=3V$ , $V_o=0.7V$ (Step 7)
Oscillation resistor	R	-	1.0	-	M $\Omega$	$V_{DD}=3V$
Oscillator frequency	$F_{osc}$	-	1.0	-	MHz	$V_{DD}=3V$

# Preliminary

## APPLICATION CIRCUIT

In the following application circuits:

- \*1 : For heavy loading application, adding an electrolytic capacitor between Vcc and Ground is recommended. The recommended value for button cell application is 10 $\mu$ F.
- \*2 : The recommended value for button cell application is 750 $\Omega$  or less.

### 4-key Application Circuit

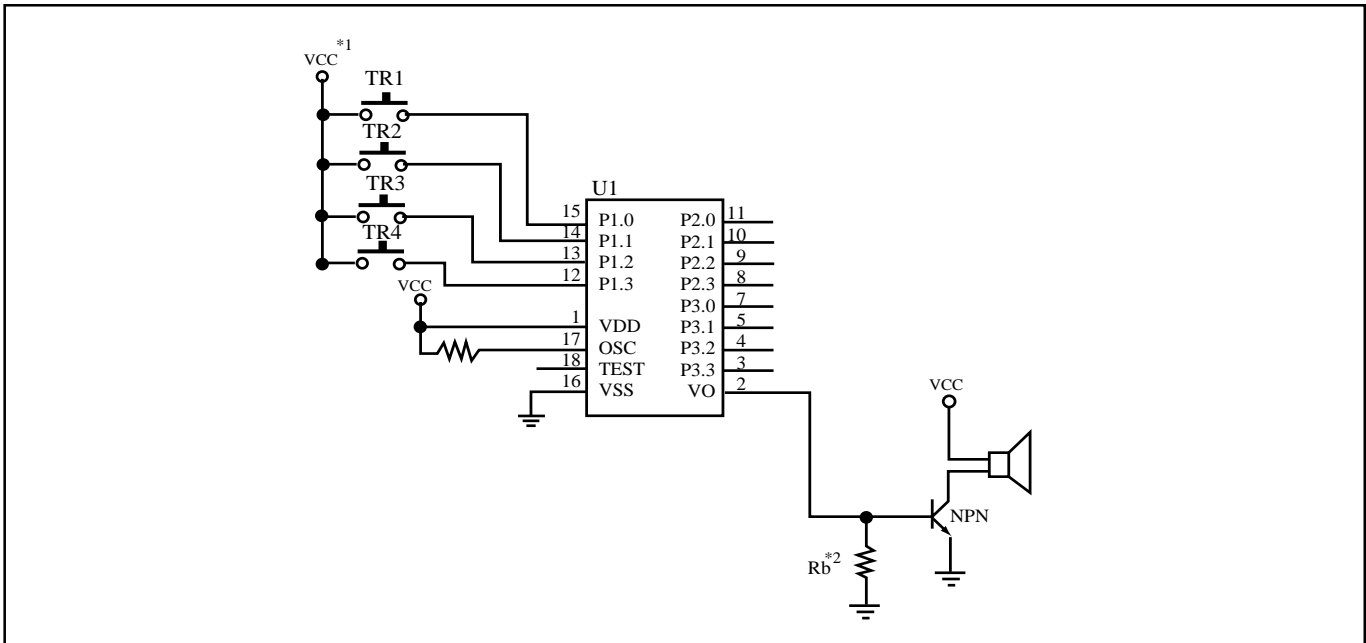

### 16-key Application Circuit

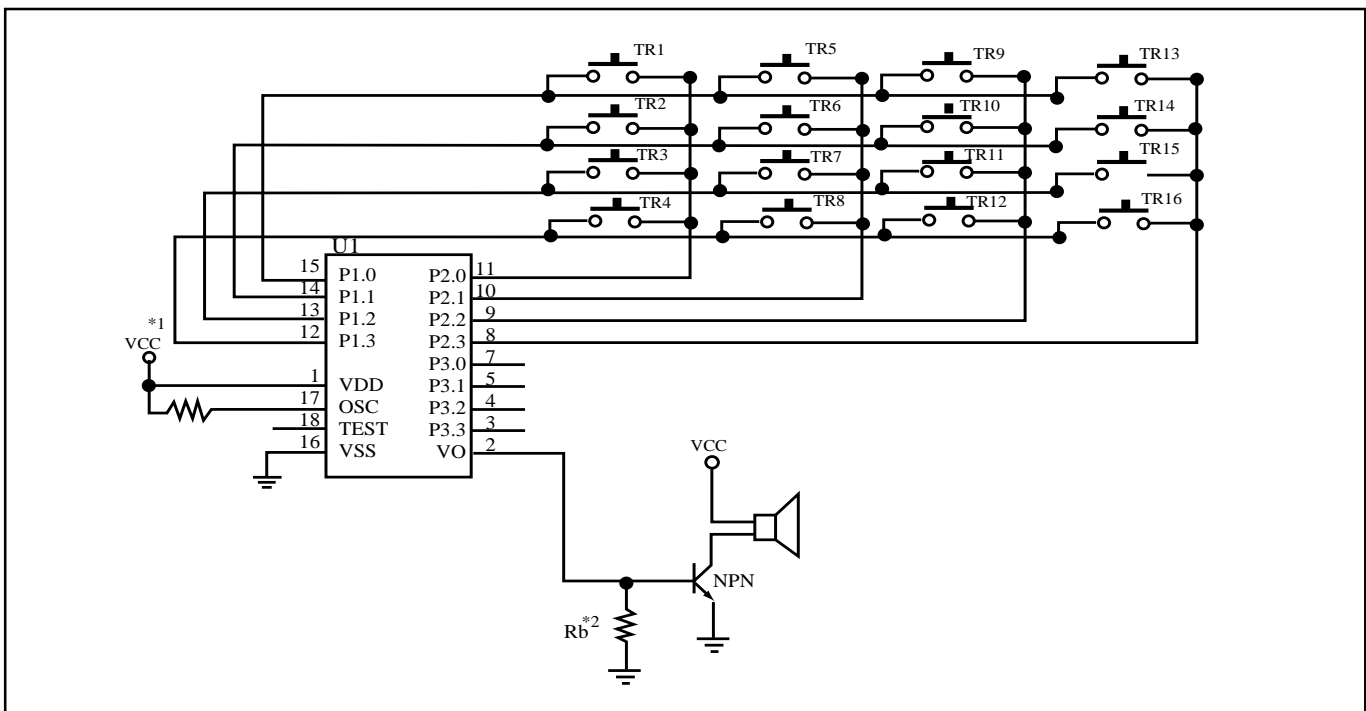

**Preliminary**

32-key Application Circuit

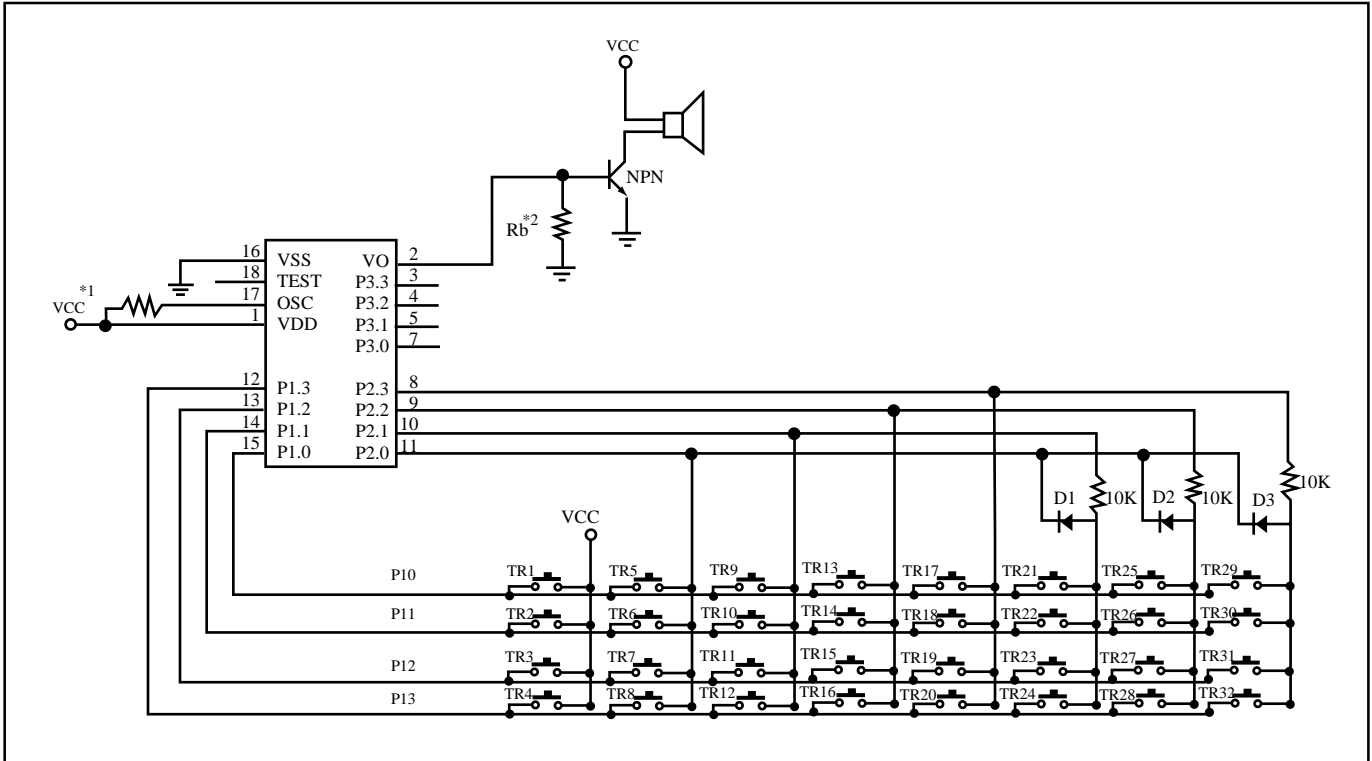

64-key Application Circuit

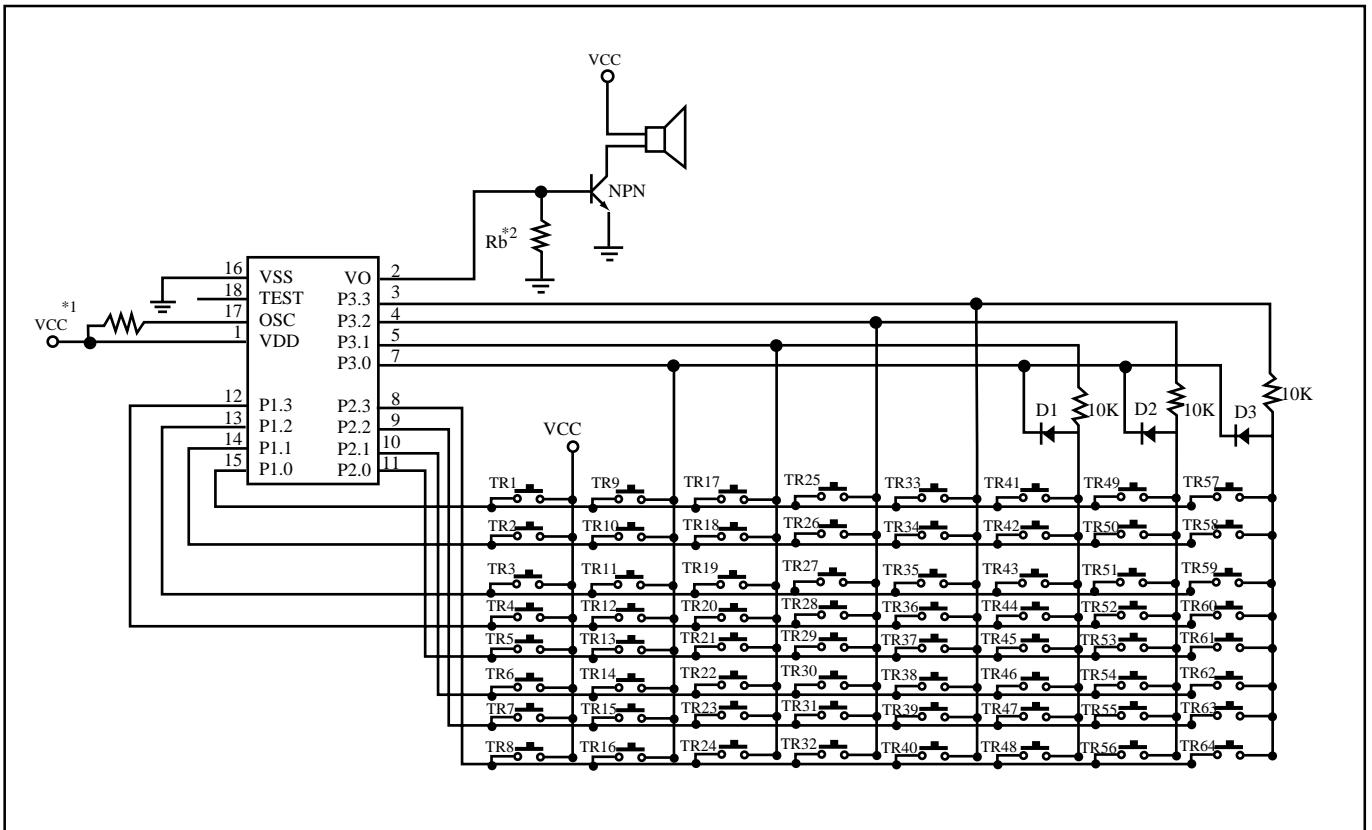



**Preliminary**

128-key Application Circuit (A)

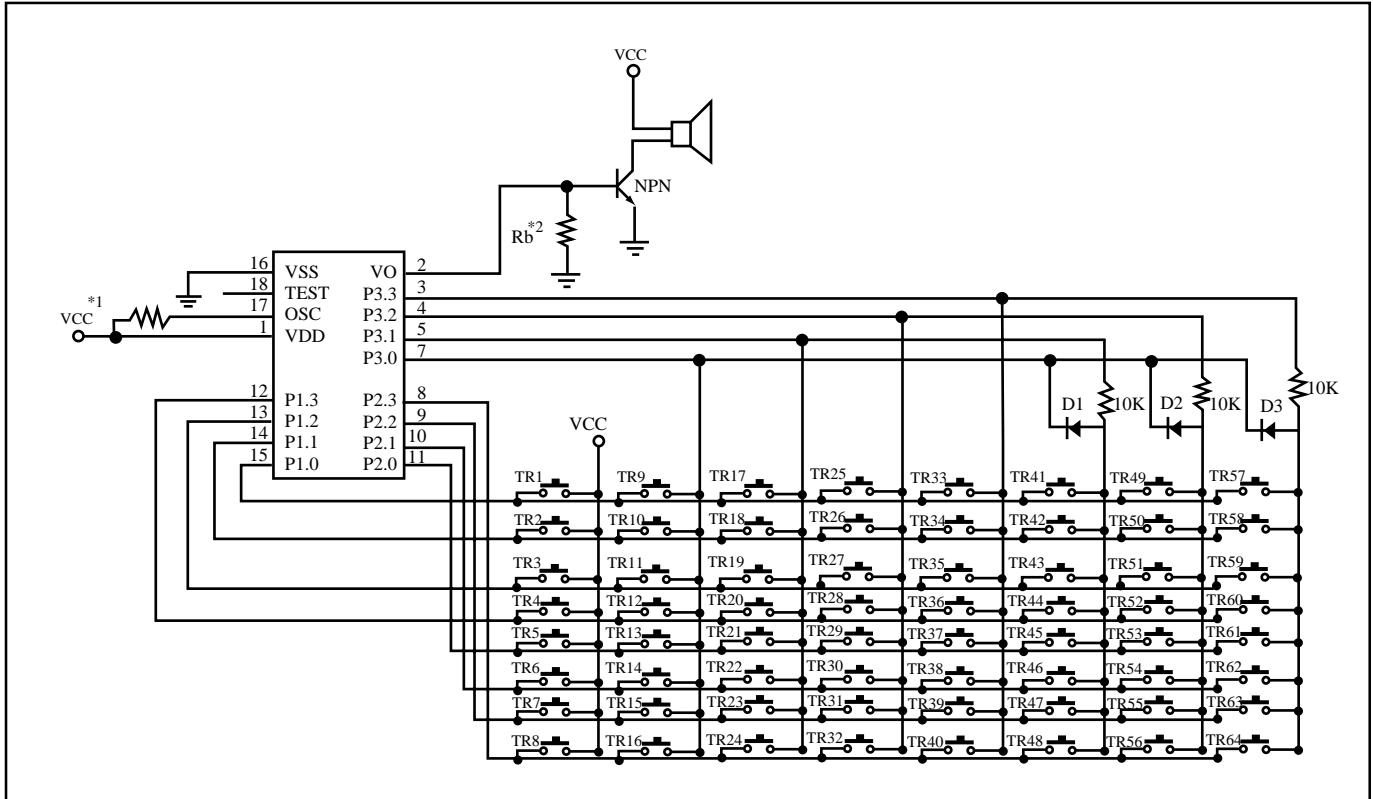

128-key Application Circuit (B)

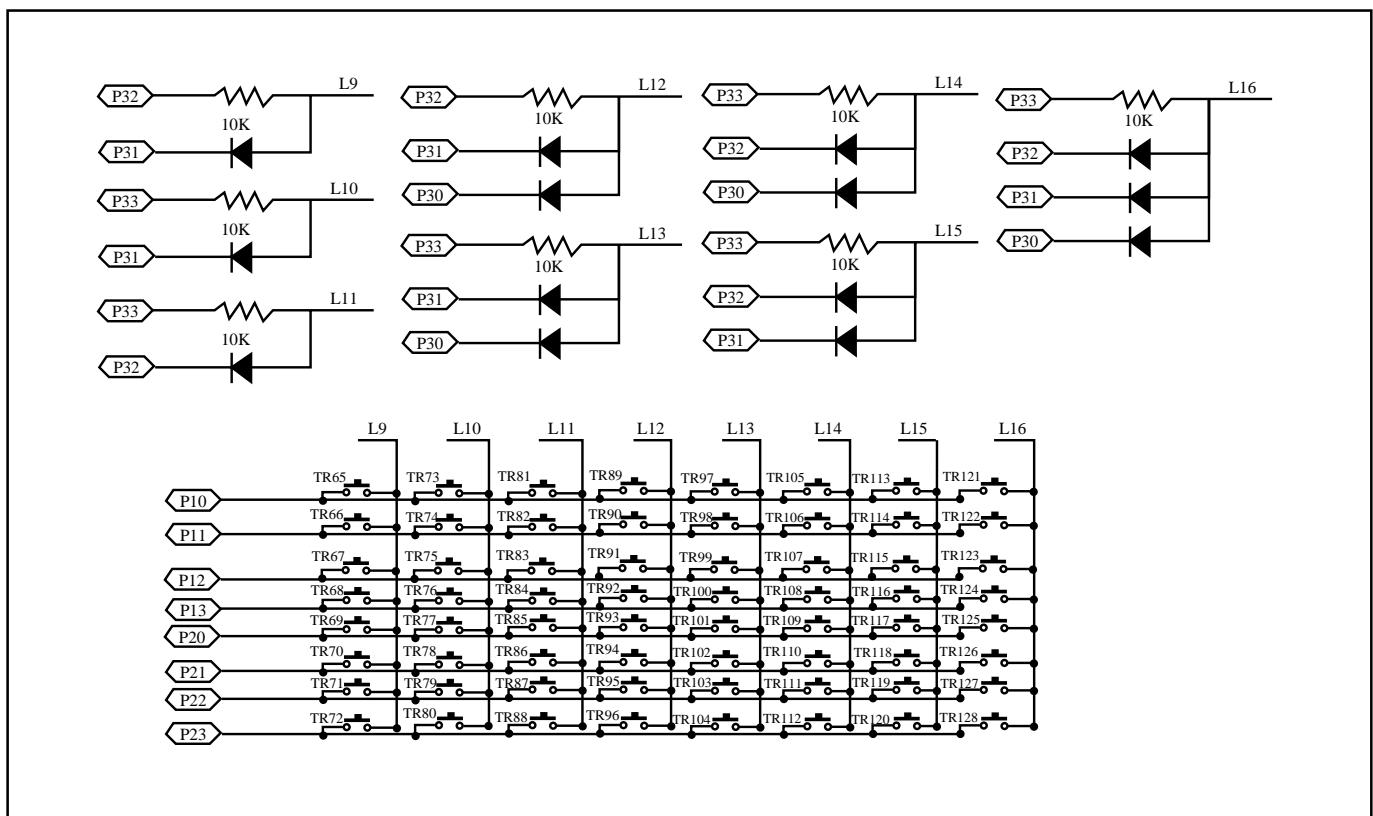



**Preliminary**

**PAD DIAGRAM**

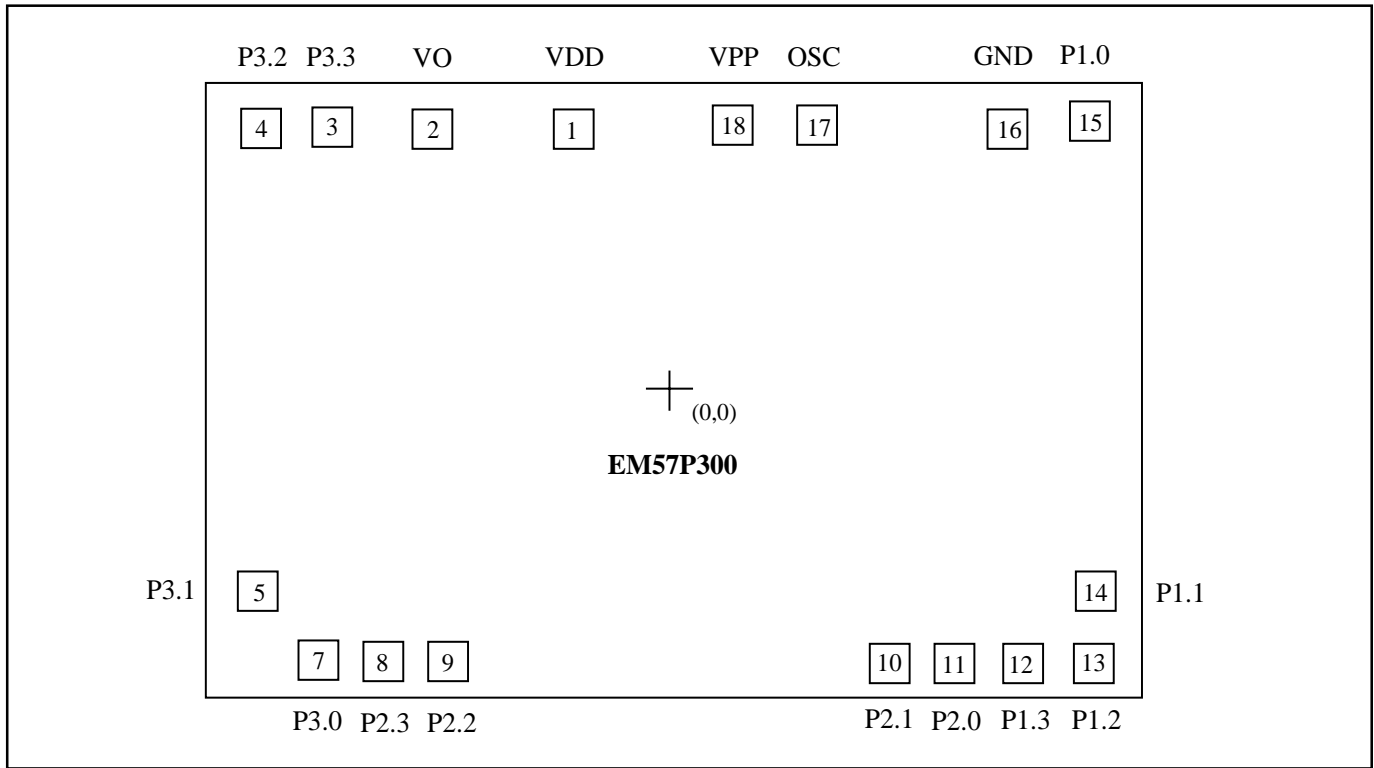

Chip Size : 3000 x 2100 um

For PCB layout, IC substrate must be connected to Vss.

Pad No.	Symbol	X	Y
1	VDD	-158.4	824.1
2	VO	-695.9	849.0
3	P3.3	-1077.0	849.0
4	P3.2	-1278.3	849.0
5	P3.1	-1310.0	-741.5
6	NC		
7	P3.0	-1128.5	-850.0
8	P2.3	-951.3	-850.0
9	P2.2	-780.0	-850.0
10	P2.1	752.2	-850.0
11	P2.0	923.5	-850.0
12	P1.3	1107.7	-850.0
13	P1.2	1284.0	-850.0
14	P1.1	1284.0	-721.5
15	P1.0	1246.7	849.0
16	GND	1014.6	824.1
17	OSC	342.9	849.0
18	VPP	182.7	849.0