



EM MICROELECTRONIC - MARIN SA

A COMPANY OF THE SWATCH GROUP

EM6415

## Sensor Signal Conditioner Circuit with 14 bits A/D Converter

### Description

The EM6415 is a high resolution A/D converter in low voltage CMOS technology intended to be used as a programmable link between one to four resistive sensors and a microcontroller.

There is no need of external components for calibration, error curve compensation or offset and gain adjustment, nor external amplifiers and sensor bridge drive circuits.

After exposure to a calibration signal/profile, all conversion parameters and profile coefficients are self calculated and stored in an external EEPROM.

In addition to a programmable dual slope 10/13/14 bit A/D conversion, EM6415 allows individual compensation of not only sensor offset and full scale errors, but also temperature error compensation of the sensor zero point and sensitivity, dynamically during the conversion process. EM6415 also contains a programmable sensor drive current source.

### Features

- Full sensor system on chip
- Four sensor channel multiplexer
- Programmable Dual slope A/D converter
- Program selectable 10, 13 or 14 bit resolution
- ADC resolves 1 $\mu$ V/Bit
- Programmable sensor offset, gain and linearity
- High flexibility in zero adjust and full scale adjust
- Sensor error compensation performed by software
- Parallel 4 bit microcontroller interface
- Self calibration of conversion parameters and profile coefficients
- Ultra low noise differential input amplifier with mask programmable gain
- Excellent linearity over full transfer curve
- Programmable current source for sensor supplies.
- Low supply voltage range 2.2V – 3.6 V
- Low operation current, 240  $\mu$ A at 800 kHz, 3V
- Ultra low power consumption (at standby or after conversion down to less than 0.1  $\mu$ A)
- Small SSOP36-300mils package

### Applications

- Portable sensor instruments
- Telemetry
- Resistive sensor interfaces
- Automotive sensors
- Industrial process control
- Consumer instruments

### Typical Application

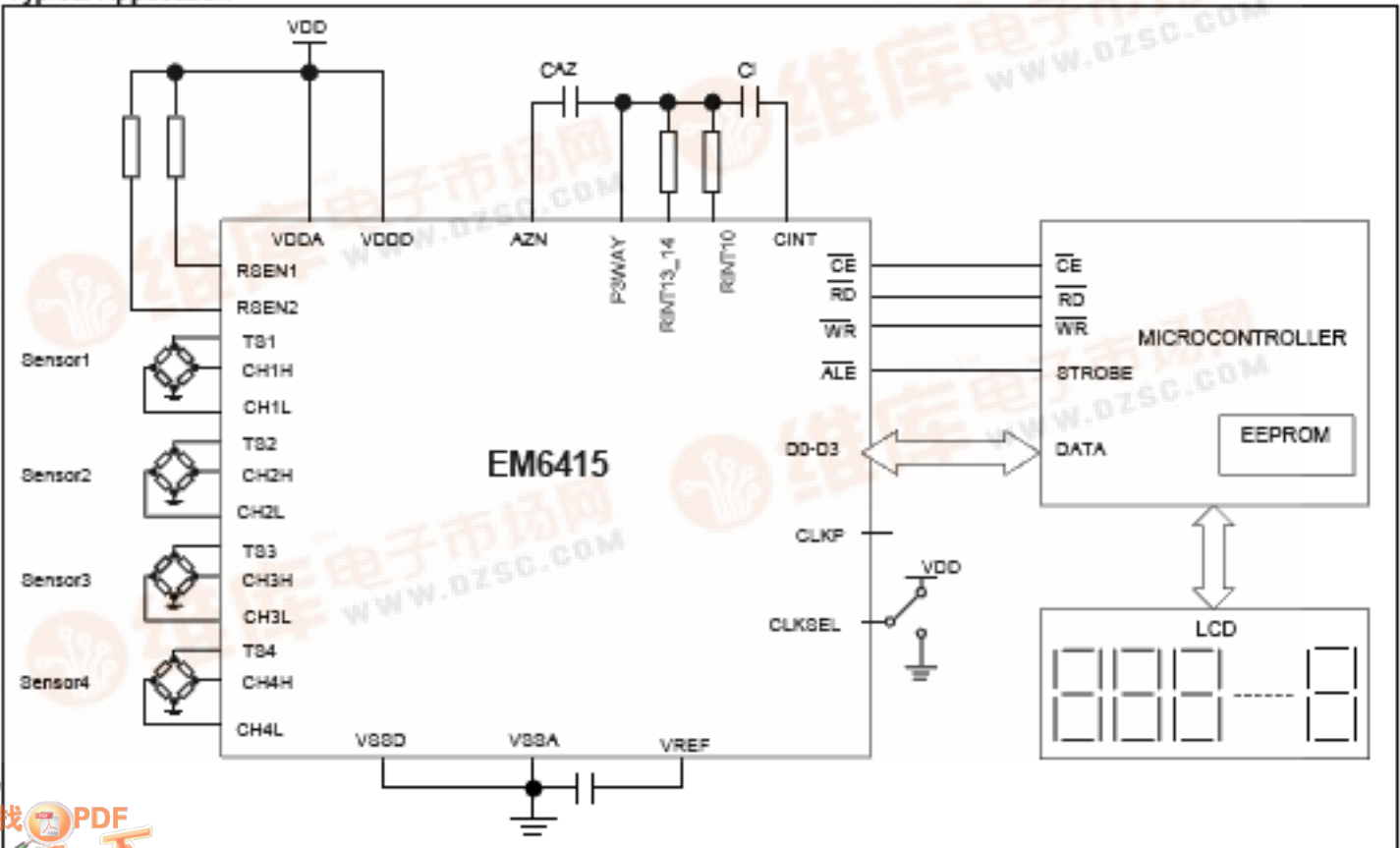

Fig. 1

## Block Diagram

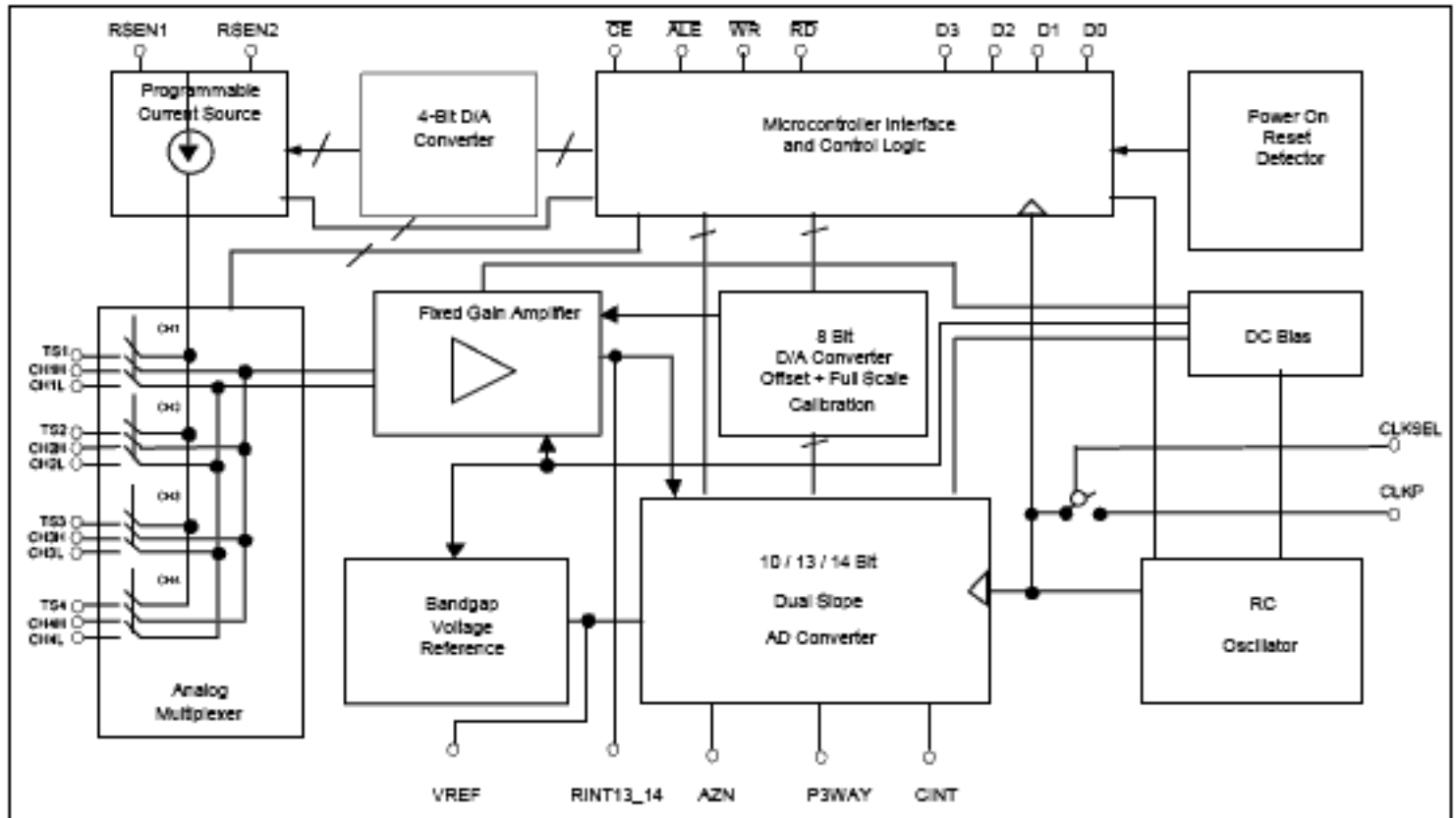

Fig. 2



# EM6415

## Absolute Maximum Ratings

Parameter	Symbol	Min	Max	Unit
Supply Voltage	V <sub>DD</sub>	-0.3	5.5	V
Voltage at remaining pins	V <sub>PIN</sub>	V <sub>SS</sub> -0.3	V <sub>DD</sub> +0.3	V
Storage temperature	T <sub>store</sub>	-55	150	°C
Operating temperature	T <sub>op</sub>	-40	+85	°C
Soldering Temperature*Time	TS <sub>MAX</sub>		250.10	°C-s

Stresses above these listed maximum ratings may cause permanent damages to the device. Exposure beyond specified operating conditions may affect device reliability or cause malfunction.

## Handling Procedures

This device has built-in protection against high static voltages or electric fields; however, anti-static precautions must be taken as for any other CMOS component. Unless otherwise specified, proper operation can only occur when all terminal voltages are kept within the voltage range. Unused inputs must always be tied to a defined logic voltage level.

## Electrical Characteristics

Operating Conditions (unless otherwise specified)

Positive supply	V <sub>DD</sub>	=	3.0V
Negative supply	V <sub>SS</sub>	=	0V
Ambient temperature	T	=	25°C
Sensor resistance	R <sub>SEN</sub>	=	300Ω to 10KΩ

## Power Supply

Parameter	Symbol	Conditions	Min.	Typ.	Max.	Unit
Operating Voltage Range	V <sub>DD</sub>	T = -20°C to 70°C	2.2	3.0	3.6	V
Current Consumption	I <sub>DD1</sub>	$\overline{CE} = V_{DD}$ at standby		0.2	1.0	μA
	I <sub>DD2</sub>	$\overline{CE} = V_{SS}$ at A/D conversion f <sub>ADOSC</sub> =800kHz	100	240	300	μA

## Programmable Internal Oscillator

Parameter	Symbol	Conditions	Min.	Typ.	Max.	Unit
Frequency	f <sub>ADOSC</sub>	D1,D0 = 00	350	500	800	kHz
Frequency Step Size	Δf <sub>ADOSC</sub>		40	70	120	kHz
Stability Against Supply Voltage Variations	Δf/f·ΔV <sub>DD</sub>	2.2V < V <sub>DD</sub> < 3.0V		15		kHz/V
Stability Against Temperature Variations	Δf/ΔT	-20°C < T < 70°C		-300		Hz/°C



# EM6415

## Sensor

Parameter	Symbol	Conditions	Min.	Typ.	Max.	Unit
Sensor Drive Current	$I_{SDRV}$	$R_{RSEN1}=1.0k\Omega$ , $R_{SEN}=4.0k\Omega$ , Program step 0 Mode S	276	300	324	$\mu A$
		$R_{RSEN1}=1.0k\Omega$ , $R_{SEN}=4.0k\Omega$ , Program step 15 Mode S	468	510	552	$\mu A$
Sensor Drive Current per Step	$I_{SDRV} /stp$	$R_{RSEN1}=1.0k\Omega$ , $R_{SEN}=4.0k\Omega$	10	15	20	$\mu A/stp$
Sensor Drive Current vs Voltage Deviation	$I_{SDRV}/V$	$R_{RSEN1}=1.0k\Omega$ , $R_{SEN}=4.0k\Omega$ $2.2V < VDD < 3.0V$	50	200	300	ppm
Sensor Bridge Resistance1	$R_{SEN1}$	$R_{RSEN1}=1.3k\Omega$ , $I_{SDRV} =200\mu A$	2.7	3.7	4.2	$k\Omega$
Sensor Bridge Resistance2	$R_{SEN2}$	$R_{RSEN2}=510\Omega$ , $I_{SDRV}=500\mu A$	1.0	1.5	2.0	$k\Omega$
RSEN1 Resistance	$R_{RSEN1}$		0.3		2.5	$k\Omega$
RSEN2 Resistance	$R_{RSEN2}$		0.3		2.5	$k\Omega$

## A/D Converter

Parameter	Symbol	Conditions	Min.	Typ.	Max.	Unit
Input Voltage Range FS	$V_{SENS}$	CH1,2,3,4H-CH1,2,3,4L To resolve 14 bits ADC	16		200	mV
Resolution	RESADC	$f_{ADOSC}=800kHz$	14			Bits
Integral Nonlinearity	INLADC	$f_{ADOSC}=800kHz$		4		LSB
Differential Nonlinearity	DNLADC	$f_{ADOSC}=800kHz$		3		LSB
Conversion Time	TCONVAD	$f_{ADOSC}=500kHz$ , 14bit		110		ms
Offset Adjust Range	$V_{OFFAD}$		-60	$\pm 40$	+60	mV
FS Fine Ajust Range	$V_{FSFAD}$	12 bit FS fine adjust	-12.5		+12.5	%FS



# EM6415

## DC Characteristics

Parameter	Symbol	Conditions	Min.	Typ.	Max	Unit
Input Low Voltage	$V_{IL}$	$\overline{ALE}$ , $\overline{RD}$ , $\overline{WR}$ , $\overline{CE}$ , CLKP, CLKSEL, D0-D3			$0.2 \cdot V_{DD}$	V
Input High Voltage	$V_{IH}$	$\overline{ALE}$ , $\overline{RD}$ , $\overline{WR}$ , $\overline{CE}$ , CLKP, CLKSEL, D0-D3	$0.8 \cdot V_{DD}$			V
Input Low Current	$I_{IL}$	$\overline{ALE}$ , $\overline{RD}$ , $\overline{WR}$ , $\overline{CE}$ , CLKP, CLKSEL, D0-D3	-20	1		nA
Input High Current	$I_{IH}$	$\overline{ALE}$ , $\overline{RD}$ , $\overline{WR}$ , $\overline{CE}$ , CLKP, CLKSEL, D0 - D3		1	20	nA
Output Low Voltage	$V_{OL}$	$I_{OL} = 2\text{mA}$ , D0 -D3		0.1	0.4	V
Output High Voltage	$V_{OH}$	$I_{OH} = -1\text{mA}$ , D0 -D3	2.4	2.95		V

## Timing Characteristics

### Data Write cycle

$V_{DD} = 3.0\text{V}$ ,  $V_{SS} = 0\text{V}$ ,  $T = 25^\circ\text{C}$ ,  $V_{OH} = 0.8 \cdot V_{DD}$ ,  $V_{OL} = 0.2 \cdot V_{DD}$

Item	Symbol	Min.	Typ.	Max.	Unit
Address Set-up Time	$T_{was}$	20	25	-	ns
Address Hold Time	$T_{wah}$	30	35	-	ns
Data Set-up Time	$T_{wds}$	20	25	-	ns
Data Hold Time	$T_{wdh}$	30	35	-	ns
$\overline{ALE}$ Pulse Width	$T_{wap}$	60	65	-	ns
$\overline{WR}$ Pulse Width	$T_{wwp}$	60	65	-	ns

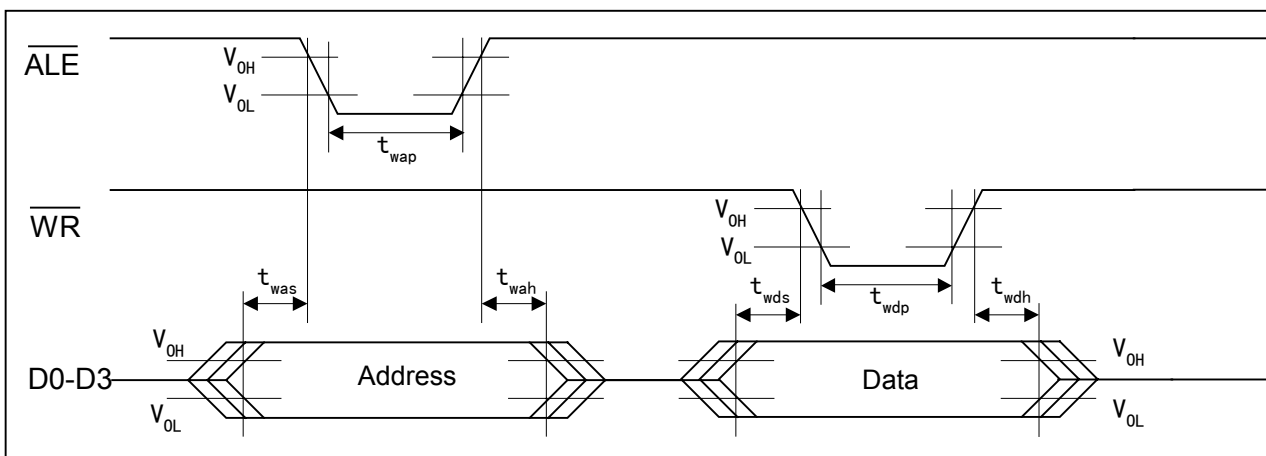

Fig. 3



# EM6415

## Data Read cycle

$V_{DD} = 3.0V, V_{SS} = 0V, T = 25\text{ }^{\circ}C, V_{OH} = 0.8 \cdot V_{DD}, V_{OL} = 0.2 \cdot V_{DD}$

Item	Symbol	Min.	Typ.	Max.	Unit
Address Set-up Time	$T_{ras}$	100		-	ns
Address Hold Time	$T_{rah}$	40	45	-	ns
Data Set-up Time	$T_{rds}$	20	25	-	ns
Data Hold Time	$T_{rdh}$	20	25	-	ns
$\overline{ALE}$ Pulse Width	$T_{rap}$	60	65	-	ns
$\overline{RD}$ Pulse Width	$T_{rtp}$	60	65	-	ns

## Timing Waveforms

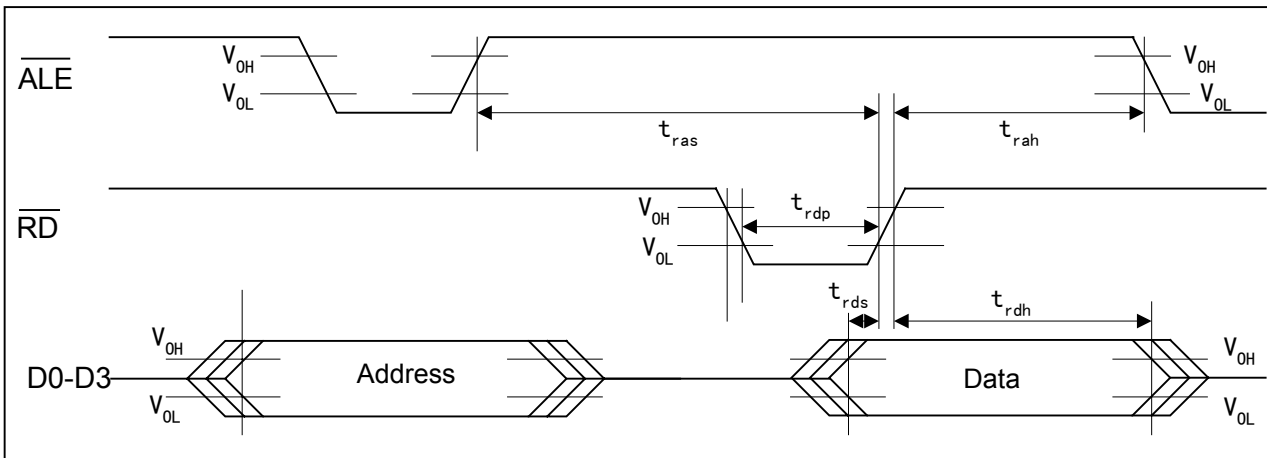

Fig. 4



# EM6415

## Functional Description

EM6415 comprises a four channel analog multiplexer followed by a fixed gain amplifier followed by the integrator of the dual slope converter, a bandgap voltage reference, RC oscillator, power on/off detector. The sensor is supplied directly by a programmable current source.

In order to minimize noise, the analog and digital circuits internal to EM6415 use separate power supplies. These power buses are brought out to separate pins and should be tied together as close as possible to the device. In addition, the output of the internal bandgap voltage reference is brought to the pin VREF, which could allow the connection of an external capacitor to V<sub>SS</sub>, if the output stability is not enough to resolve 1μV/bit ADC.

## Programming Procedure

### Nibble organization and Bit order:

<b>Bit</b>	3	2	1	0
<b>Order</b>	high	→	→	low

### Latch Address (LAD) and Functions

LAD	Function	Bits D0-D3	WR/RD	Note
0	FS fine adjust	0-3	WR	
1	FS fine adjust	4-7	WR	
2	FS fine adjust	8-11	WR	
3	OS rough adjust	0-3	WR	
4	OS rough adjust	4-7	WR	
5	FS rough adjust	0-3	WR	
6	FS rough adjust	4-7	WR	
7	Bridge current	0-3	WR	
8	ADC status & ADC output AD0, AD1	0-3	RD	(note 1)
9	ADC output AD2-AD5	2-5	RD	(note 2)
10	ADC output AD6-AD9 & T0-T3	6-9	RD	(note 2)
11	ADC output AD10-AD13 & T4-T7	10-13	RD	(note 2)
12	ADC resolution (10, 13, 14)	0-3	WR	(note 3)
13	Perform ADC conversion (T, R, S, P)	0-3	WR	(note 4)
14	Select Sensor-Port (1,2,3,4) & RSEN (1,2)	0-3	WR	(note 5)
15	don't use	-		

### Note 1: ADC Status & AD0, AD1 (LAD=8)

Bit	Function	Note
D0	CC	Conversion complete = 1
D1	COVFL	Conversion overflow = 1
D2	AD0	ADC Bit 0
D3	AD1	ADC Bit 1

### Note 2: ADC read out

Latch Address	11				10				9				8	
Buffer Bit	3	2	1	0	3	2	1	0	3	2	1	0	3	2
<b>ADC Bits</b>														
<b>Sensor AD-14</b>	13	12	11	10	9	8	7	6	5	4	3	2	1	0
<b>Sensor AD-13</b>	12	11	10	9	8	7	6	5	4	3	2	1	0	-
<b>Sens/Pow AD10</b>	9	8	7	6	5	4	3	2	1	0	-	-	-	-
<b>Top of B AD10</b>	9	8	7	6	5	4	3	2	1	0	-	-	-	-



# EM6415

## Note 3: ADC resolution & frequency select (LAD 12)

<i>Bit</i>	<i>Select</i>	<i>Function</i>
D1, D0	00	clock 500kHz
	01	clock 600kHz
	10	clock 700kHz
	11	clock 800kHz
D3, D2	00	10 Bit ADC
	01	13 Bit ADC
	10	13 Bit ADC
	11	14 Bit ADC

## Note 4: ADC conversion select (LAD=13)

<i>Bit</i>	<i>Select</i>	<i>Function</i>	<i>Note</i>
D1, D0	-	don't use	
D3, D2	00	(T) top of sensor bridge with $I_{SDRV} / 2$	(note 6)
	01	(R) A/D ramp height	(note 7)
	10	(S) sensor bridge signal $I_{SDRV}$	(note 8)
	11	(P) power supply voltage	(note 9)

## Note 5: ADC conversion select (LAD=14)

<i>Bit</i>	<i>Select</i>	<i>Function</i>
D0	0	RSENS1
	1	RSENS2
D2, D1	00	Sensor 1 on TS1
	01	Sensor 2 on TS2
	10	Sensor 3 on TS3
	11	Sensor 4 on TS4
D3	-	Don't use

**Note 6:** Top of sensor bridge, e.g. temperature (ToB – VSSA)

**Note 7:** Select ramp height if CC=0, ramp height > 1.5V

For lowest ADC jitter, chose ramp height > 1.5V. To do so, run A/D ramp height conversion and read CC (conversion complete, LAD8, Bit0). Lower the clock frequency until CC=0.

**Note 8:** Sensor bridge signal, e.g. pressure (CH1L – CH1H)

**Note 9:** Power supply voltage of EM6415 circuit



## Integrator

This signal can be seen on pin CINT

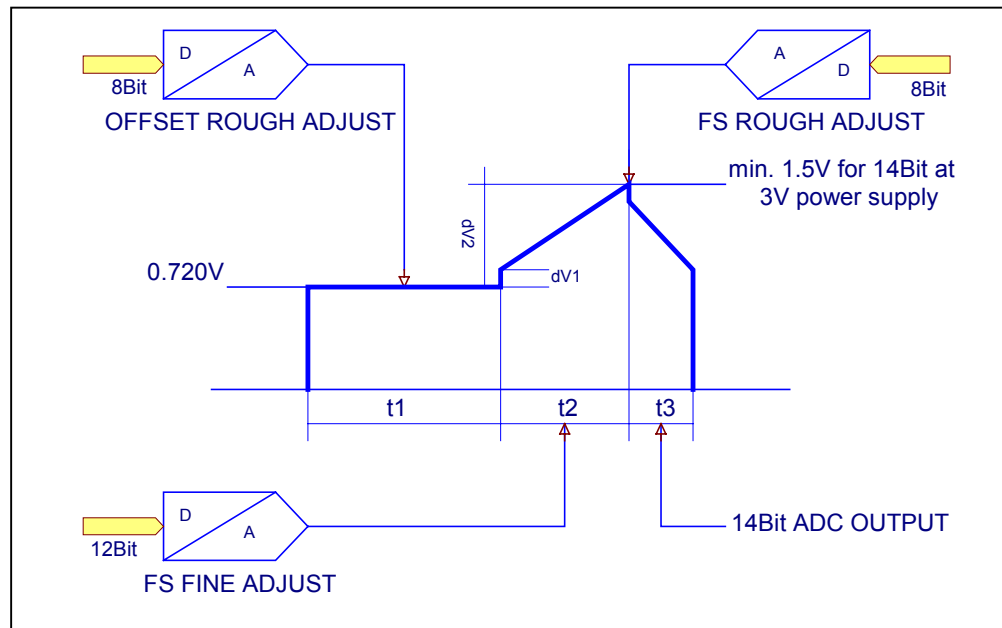

Fig. 5 Integrator ramp

Time	Phase	Execution
t1	Autozero phase	Set up of integrator starting point
t2	FS fine adjust	Signal integration with preprogrammed counter time length t2
t3	FS rough adjust	De-integration with preprogrammed reference voltage, time length of t3 = ADC output counts

dV1 is the Offset Rough Adjust  
dV2 is the Integrator Ramp Length

Offsets and other system mismatch such as the zero drift of operational amplifiers, long term instabilities or supply voltage fluctuations are cancelled during the Autozero phase.  
Sensitivity and full-scale range adjustments are done during rampup and rampdown of the dual slope integrator.



# EM6415

## Pad Description & Pin Assignment in SSOP36

PIN Nr	Name	I/O	Description
10	TS1		Top of sensor1 bridge connection pin
11	CH1H		Sensor1 channel high signal in
12	CH1L		Sensor1 channel low signal in
13	TS2		Top of sensor2 bridge connection pin
14	CH2H		Sensor2 channel high signal in
15	CH2L		Sensor2 channel low signal in
16	TS3		Top of sensor3 bridge connection pin
17	CH3H		Sensor3 channel high signal in
18	CH3L		Sensor3 channel low signal in
19	TS4		Top of sensor4 bridge connection pin
20	CH4H		Sensor4 channel high signal in
21	CH4L		Sensor4 channel low signal in
2	D0P	I/O	Microprocessor Port Data 0
1	D1P	I/O	Microprocessor Port Data 1
36	D2P	I/O	Microprocessor Port Data 2
35	D3P	I/O	Microprocessor Port Data 3
31	$\overline{RD}$	I	Read strobe for BUS read (active low)
32	$\overline{ALE}$	I	Address latch enable (active low)
33	$\overline{CE}$	I	Chip enable (active low)
34	$\overline{WR}$	I	Write strobe for BUS write (active low)
22	CINT		Connection to integrator capacitor
23	AZN		Connection to auto-zero capacitor
24	P3WAY		3 way connection for integrator
25	RINT13_14		Connection of resistor for integrator
26	RINT10		Connection of resistor for integrator when 10 bit conversion used
8	RSEN1		Resistor to select sensor bridge1 maximum drive current
9	RSEN2		Resistor to select sensor bridge2 maximum drive current
3	CLKP	I	External clock input
5	CLKSEL	I	Internal/external clock select
6	VDDD		Positive supply voltage of digital part
7	VDDA		Positive supply voltage of analog part
29	VSSA		Negative supply voltage of analog part
30	VSSD		Negative supply voltage of digital part
27	VREF	O	Reference voltage
4, 28	NC		Not connected

I: Input

O: Output



# EM6415

## Package Information

### SSOP36 – 300 mils

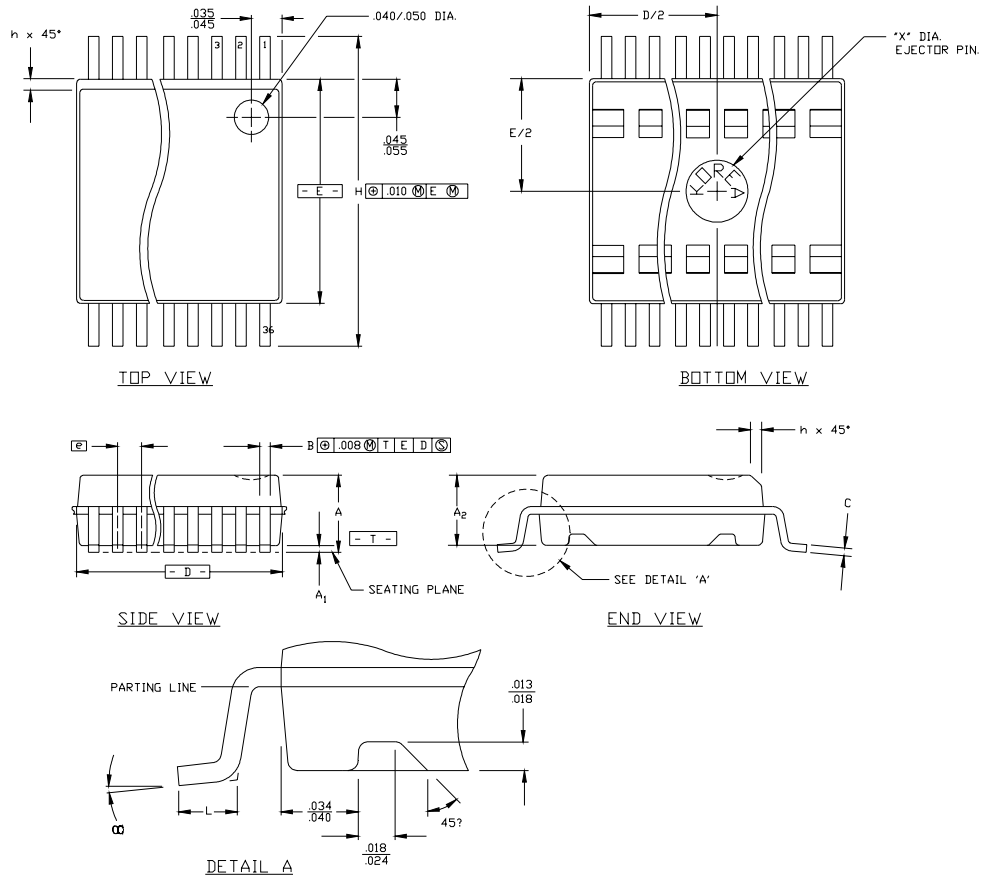

Symbol	Common dimensions (inches)			Note
	Min	Nom	Max	
A	0.097	0.101	0.104	
A1	0.0050	0.009	0.0115	
A2	0.090	0.092	0.094	
B	0.012	0.014	0.017	
C	0.0091	0.010	0.0125	
D	0.602	0.607	0.612	
E	0.292	0.296	0.299	
e		0.0315 BSC		
H	0.400	0.406	0.410	
h	0.010	0.013	0.016	
L	0.024	0.032	0.040	
X	0.085	0.093	0.100	
$\alpha$	0°	5°	8°	

Symbol	Common dimensions (mm)			Note
	Min.	Nom	Max	
A	2.46	2.56	2.64	
A1	0.127	0.22	0.29	
A2	2.29	2.34	2.39	
B	0.31	0.36	0.43	
C	0.23	0.25	0.32	
D	15.29	15.42	15.54	
E	7.42	7.52	7.59	
e		0.80 BSC		
H	10.16	10.31	10.41	
h	0.25	0.33	0.41	
L	0.61	0.81	1.02	
X	2.16	2.36	2.54	
$\alpha$	0°	5°	8°	



# EM6415

## Ordering Information

The EM6415 has metal mask options for the Gain of the Input Amplifier (between 1 and 150 max) and for the Offset Adjust Range. Contact EM Microelectronic for availability of different options not shown in table below. Please make sure to order the exact Part Number when ordering.

Part Number	Version	Input Amplifier Gain	OS/FS Rough Adjust (note 1)	Offset Adjust Range	Delivery Form
EM6415V1WS11	V1	5	Separate Registers for each sensor	-40mV to +40mV	Sawn wafer, 11 mils thickness
EM6415V1SS36A					36-pin SSOP, Stick
EM6415V1SS36B					36 pin SSOP, Tape & Reel
EM6415V2WS11	V2	5	Common Registers for the 4 sensors	-40mV to +40mV	Sawn wafer, 11 mils thickness
EM6415V2SS36A					36-pin SSOP, Stick
EM6415V2SS36B					36 pin SSOP, Tape & Reel
EM6415V3WS11	V3	150	Separate Registers for each sensor	-40mV to +40mV	Sawn wafer, 11 mils thickness
EM6415V3SS36A					36-pin SSOP, Stick
EM6415V3SS36B					36 pin SSOP, Tape & Reel
EM6415V%WS11	V%	custom	custom	custom	Sawn wafer, 11 mils thickness
EM6415V%SS36A					36-pin SSOP, Stick
EM6415V%SS36B					36 pin SSOP, Tape & Reel

**Note 1:** LAD 3, 4, 5, 6

For die size information and pad location diagram, please contact EM Microelectronic-Marín SA.

EM Microelectronic-Marín SA cannot assume responsibility for use of any circuitry described other than circuitry entirely embodied in an EM Microelectronic-Marín SA product. EM Microelectronic-Marín SA reserves the right to change the circuitry and specifications without notice at any time. You are strongly urged to ensure that the information given has not been superseded by a more up-to-date version.