



GENERAL DESCRIPTION

The EM78860 is an 8-bit RISC type microprocessor with low power , high speed CMOS technology . Integrated onto a single chip are on_chip watchdog (WDT) , RAM , ROM , programmable real time clock / counter , internal interrupt , power down mode , LCD driver and tri-state I/O . The EM78860 provides a single chip solution to design a message display .

FEATURES

CPU

- Operating voltage range : **2.5V~5.5V**
- 16Kx13 on chip ROM
- 2.8Kx8 on chip RAM
- Up to 32 bi-directional tri-state I/O ports
- 8 Level stack for subroutine nesting
- 8-bit real time clock/counter (TCC)
- Two sets of 8 bit counters can be interrupt sources
- Selective signal sources and with overflow interrupt
- Programmable free running on chip watchdog timer
- 99.9% single instruction cycle commands
- Four modes (internal clock 3.679MHz, external 32.768KHz)
 1. Sleep mode : CPU and 3.679MHz clock turn off, 32.768KHz clock turn off
 2. Idle mode : CPU and 3.679MHz clock turn off, 32.768KHz clock turn on
 3. Green mode : 3.679MHz clock turn off, CPU and 32.768KHz clock turn on
 4. Normal mode : 3.679MHz clock turn on , CPU and 32.768KHz clock turn on
- Low battery detector
- Input port wake up function
- 8 interrupt source , 4 external , 3 internal
- **100 pin QFP or chip**
- Port key scan function
- Port interrupt , pull high and open drain functions
- Clock frequency 32.768KHz externally

LCD

- LCD operation voltage chosen by software
- Common driver pins : 16
- Segment driver pins : 60
- 1/4 bias
- 1/8,1/16 duty

APPLICATION

1. adjunct units
2. data bank





PIN ASSIGNMENTS

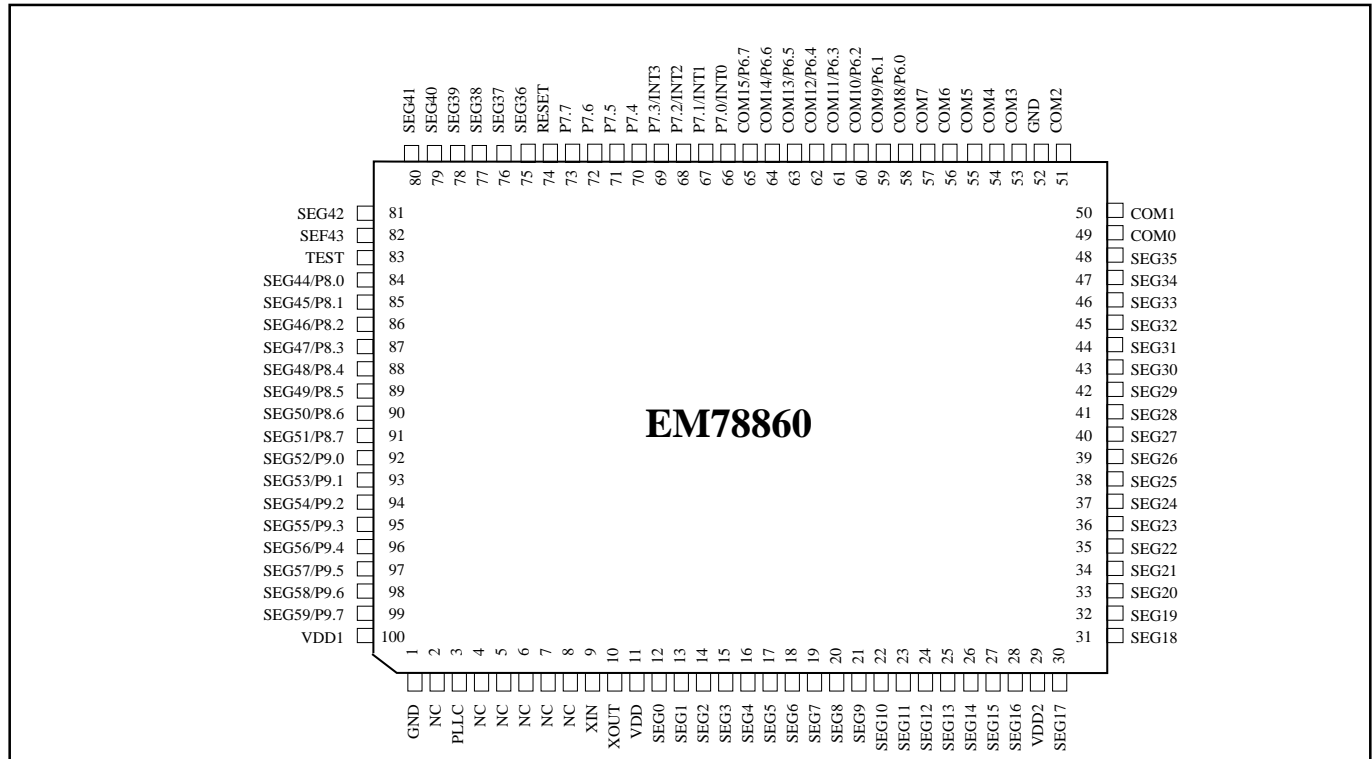

FUNCTIONAL BLOCK DIAGRAM

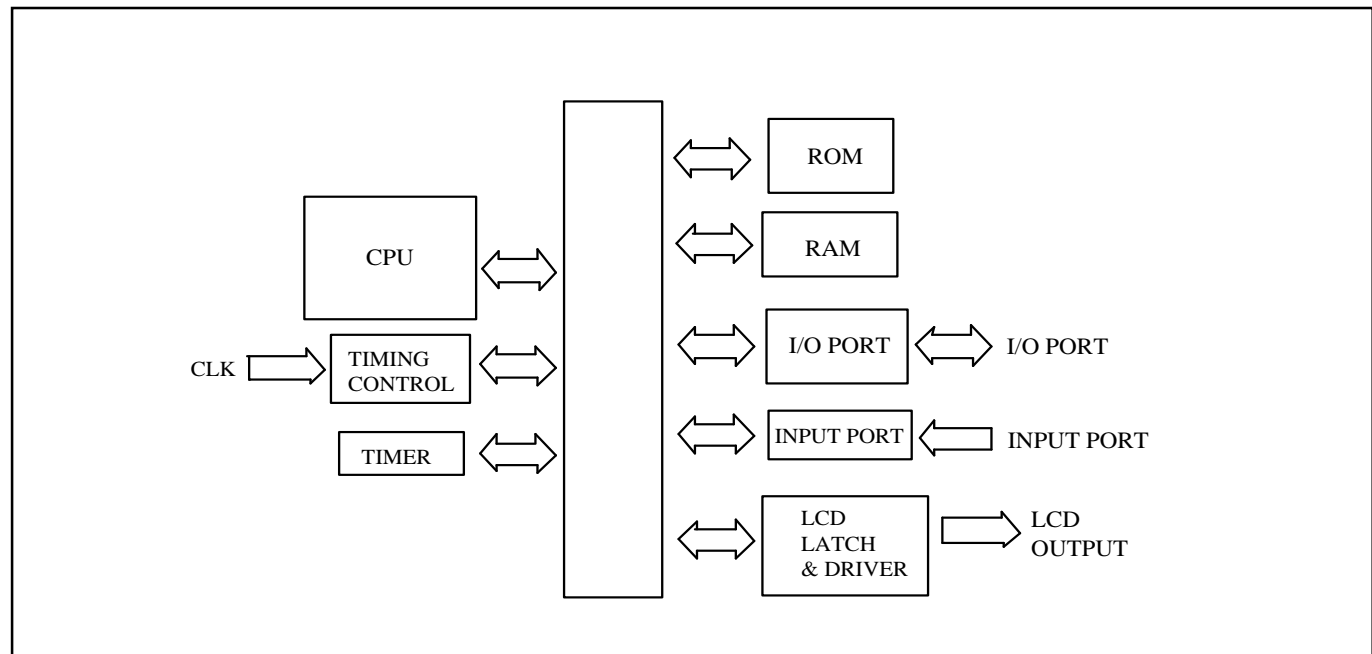

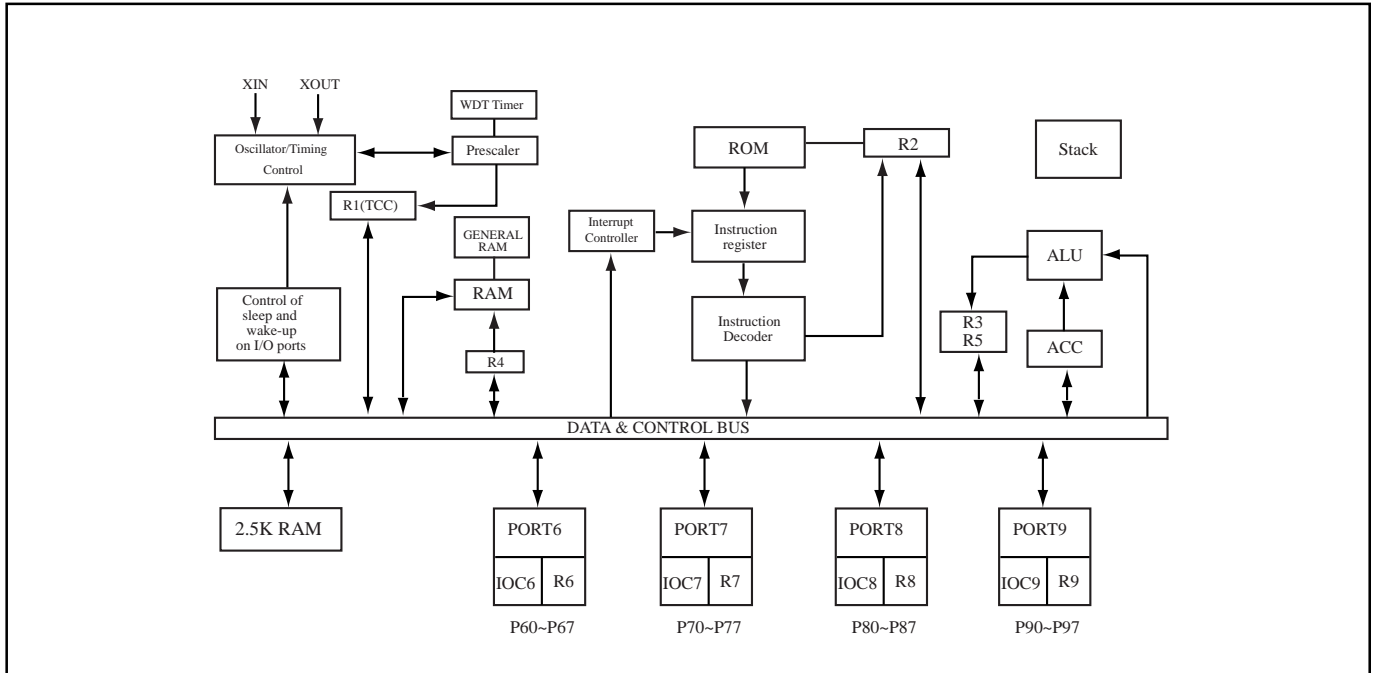

PIN DESCRIPTIONS

Symbol	Type	Function
VDD	POWER	Power
GND	POWER	Ground
XTin	I	Input pin for 32.768 kHz oscillator
XTout	O	Output pin for 32.768 kHz oscillator
PLLCC	I	Phase loop lock capacitor, connect a capacitor 0.01 μ to 0.047 μ with GND
COM0..COM7	O	Common driver pins of LCD drivers
COM8..COM15	O (PORT6)	
SEG0..SEG43	O	Segment driver pins of LCD drivers
SEG44..SEG51	O (PORT8)	
SEG52..SEG59	O (PORT9)	
INT0	PORT7(0)	PORT7(0)~PORT7(3) signal can be interrupt signals.
INT1	PORT7(1)	
INT2	PORT7(2)	
INT3	PORT7(3)	
P7.0~P7.7	PORT7	PORT 7 can be INPUT or OUTPUT port each bit. Internal Pull high function. Key scan function. Bit6,7 open drain function.
P6.0~P6.7	PORT6	PORT 6 can be INPUT or OUTPUT port each bit. And shared with Common signal.
P8.0~P8.7	PORT8	PORT 8 can be INPUT or OUTPUT port each bit. And shared with Common signal.
P9.0~P9.7	PORT9	PORT 9 can be INPUT or OUTPUT port each bit. And shared with Common signal.
TEST	I	Test pin into test mode , normal low
RESET	I	

FUNCTION DESCRIPTION

Operational Registers

R0 (Indirect Addressing Register)

R0 is not a physically implemented register. It is useful as indirect addressing pointer. Any instruction using R0 as register actually accesses data pointed by the RAM Select Register (R4).

R1 (TCC)

- Increased by an internal signal edge applied to TCC , or by the instruction cycle clock.
- Written and read by the program as any other register.

R2 (Program Counter)

- The structure is depicted in Fig. 4.
- Generates 16Kx13 on-chip ROM addresses to the relative programming instruction codes.
- "JMP" instruction allows the direct loading of the low 10 program counter bits.
- "CALL" instruction loads the low 10 bits of the PC, PC+1, and then push into the stack..
- "RET" ("RETL k", "RETI") instruction loads the program counter with the contents at the top of stack.
- "MOV R2,A" allows the loading of an address from the A register to the PC, and the ninth and tenth bits are cleared to "0".
- "ADD R2,A" allows a relative address be added to the current PC, and contents of the ninth and tenth bits are cleared to "0".
- "TBL" allows a relative address be added to the current PC, and contents of the ninth and tenth bits don't change.
- The most significant bit (A10~A13) will be loaded with the content of bit PS0~PS3 in the status register (R5) upon the execution of a "JMP", "CALL", "ADD R2,A", or "MOV R2,A" instruction.

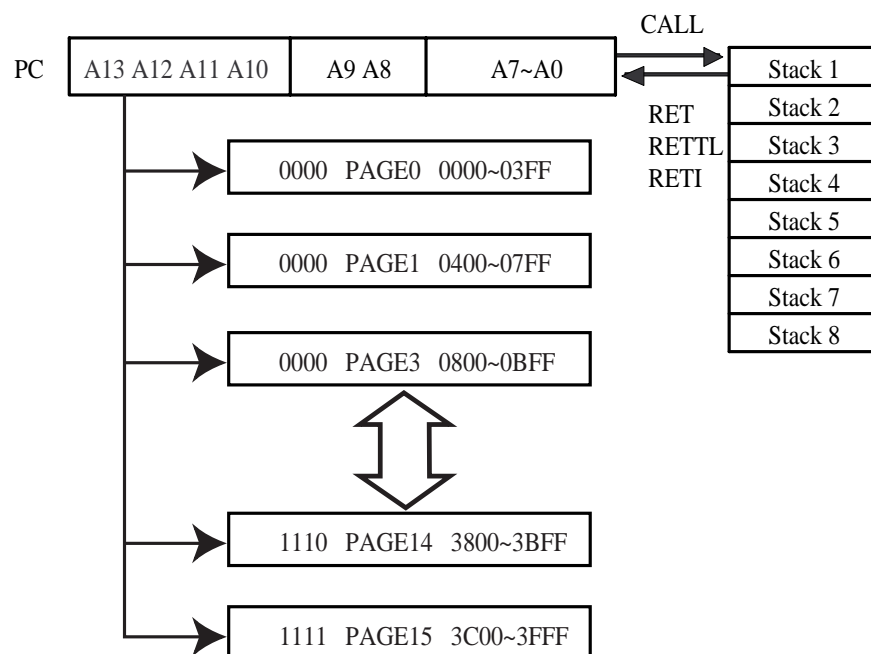

Fig.4 Program counter organization

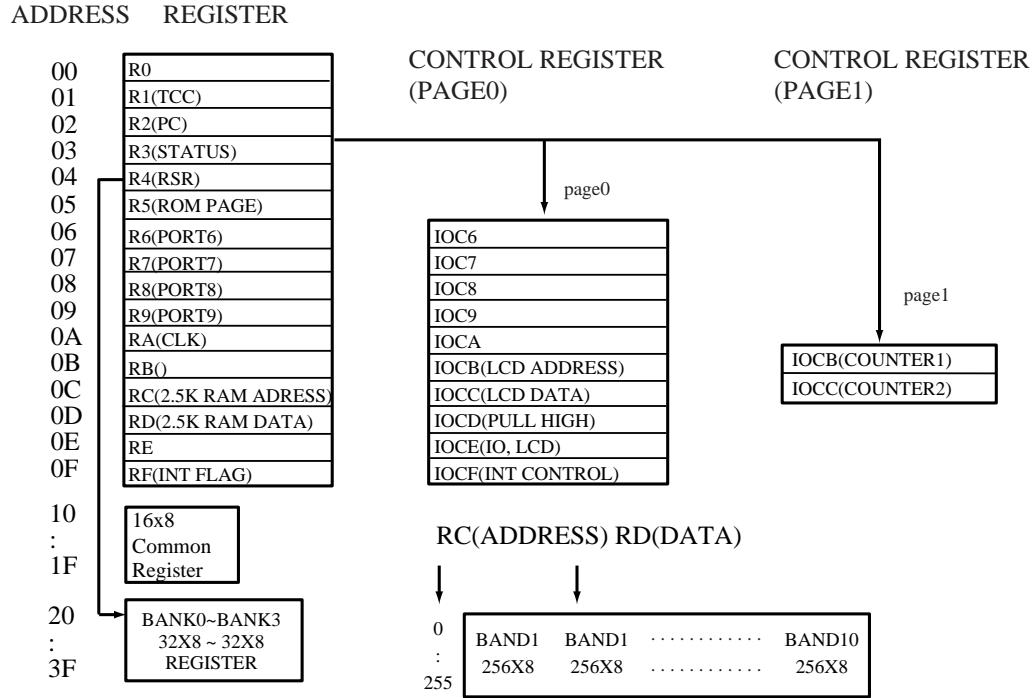

Fig.5 Data memory configuration

R3 (Status Register)

7	6	5	4	3	2	1	0
-	PAGE	-	T	P	Z	DC	C

- Bit 0 (C) : Carry flag
- Bit 1 (DC) : Auxiliary carry flag
- Bit 2 (Z) : Zero flag
- Bit 3 (P) : Power down bit. Set to 1 during power on or by a “WDTC” command and reset to 0 by a “SLEP” command.
- Bit 4 (T) : Time-out bit. Set to 1 by the “SLEP” and “WDTC” command, or during power up and reset to 0 by WDT time out.

EVENT	T	P	REMARK
WDT TIME OUT sleep mode	0	0	
WDT time out (not sleep mode /RESET wake up from sleep	0	1	
power up	1	1	
Low pulse on /RESET	x	x	x . . don't care

- Bit 5 : unused
- Bit 6 PAGE : changed IOCB~IOCE to another page, 0/1→page0/page1
- Bit 7 unused



R4 (RAM Select Register)

- Bit 0 ~ 5 are used to select up to 64 register in the indirect addressing mode.
- Bit 6 ~ 7 determine which bank is activated among the 4 banks.
- See the configuration of the data memory in Fig.4.

R5 (Program Page Select Register)

7	6	5	4	3	2	1	0
-	-	-	-	PS3	PS2	PS1	PS0

- Bit 0 (pS0) ~ 3 (PS3) Page selec bits.

Page select bits

PS3	PS2	PS1	PS0	program memory page (Address)
0	0	0	0	Page 0
0	0	0	1	Page 1
0	0	1	0	Page 2
0	0	1	1	Page 3
0	1	0	0	Page 4
0	1	0	1	page 5
0	1	1	0	Page 6
0	1	1	1	Page 7
1	0	0	0	Page 8
1	0	0	1	Page 9
1	0	1	0	Page 10
1	0	1	1	Page 11
1	1	0	0	Page 12
1	1	0	1	Page 13
1	1	1	0	Page 14
1	1	1	1	Page 15

- User can use PAGE instruction to change page. To maintain program page by user. Otherwise, user can use far jump (FJMP) or far call (FCALL) instructions to program user's code. And the program page is maintained by EMC's complier. It will change user's program by inserting instruction within program.

- Bit4~7 : unused

R6 ~R9 (Port 6 ~ Port 9)

- Five 8-bit I/O registers.

RA

7	6	5	4	3	2	1	0
IDLE	/358E	/LPD	/LOW-BAT	0	0	0	0

- Bit0 ~ Bit3 unused, please set to "0"

- Bit4(Read Only)(Low battery signal) 0/1 = Battery voltage is low/Normal .
If the battery voltage is under 3.6V then sends a '0' signal to RA register bit4 or a '1' signal to this Bit if VDD is over 3.8V.
- Bit5(read/Write)(Low battery detect enable)
0/1 = low battery detect DISABLE/ENABLE.
The relation between /LPD,/POVD and /LOW_BAT can see Fig6.

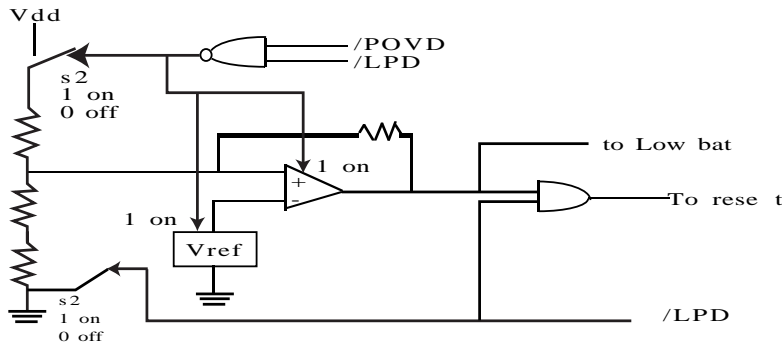

Fig6. The relation between /LPD,/POVD

- Bit6(read/write)(PLL enable signal)
0/1=DISABLE/ENABLE
The relation between 32.768K and 3.679M can see Fig7.

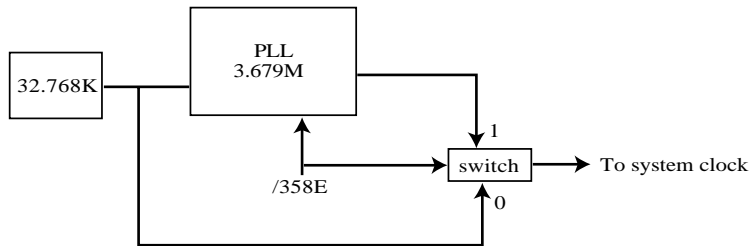

Fig7. The relation between 32.768K and 3.679K .

- Bit7 IDLE: sleep mode selection bit
0/1=sleep mode/IDLE mode. This bit will decide SLEP instruction which mode to go.
These IDLE mode can be waken up by TCC clock or Watch Dog or PORT9 and run from "SLEP" next instruction.
These SLEEP mode can be waken up by Watch Dog or PORT9 and run from address "00".

	SLEEP mode	IDLE mode	GREEN mode	NORMAL mode
	RA(7,6)=(0,0) + SLEP	RA(7,6)=(1,0) + SLEP	RA(7,6)=(x,0) no SLEP	RA(7,6)=(x,1) no SLEP
TCC time out	X	Wake-up + Interrupt + Next instruction	Interrupt	Interrupt
WDT time out	RESET	Wake-up + Next instruction	RESET RESET	RESET RESET
Port9 wake-up	RESET	Wake-up + Next instruction		



RB

Empty register, please don't use.

RC(2.5k RAM address)(read/write)

7	6	5	4	3	2	1	0
CIDA7	CIDA6	CIDA5	CIDA4	CIDA3	CIDA2	CIDA1	CIDA0

- Bit 0 ~ Bit 7 select CALLER ID RAM address up to 256.

RD(2.5k RAM address)(read/write)

- Bit 0 ~ Bit 8 are CALLER ID RAM data transfer register.
User can see IOCA register how to select CID RAM banks.

RE(LCD Driver,WDT Control)(read/write)

7	6	5	4	3	2	1	0
-	/WDTE	/WUP9H	/WUP9L	/WURING	LCD_C2	LCD_1	LCD_M

- Bit0 (LCD_M):LCD_M decides the methods, including duty, bias, and frame frequency.
- Bit1~Bit2 (LCD_C#):LCD_C# decides the LCD display enable or blanking. change the display duty must set the “LCD_C2,LCD_C1” to “00”.

LCD_C2,LCD_C1	LCD Display Control	LCD_M	duty	bias
0 0	Change duty	0	1/16	1/4
	Disable(turn off LCD)	1	1/8	1/4
0 1	Blanking	:	:	
1 1	LCD display enable	:	:	

- Bit3 unused. Please set to "0"
- Bit4(/WUP9L, PORT9 low nibble Wake Up Enable) : used to enable the wake-up function of low nibble in PORT9, (1/0=enable/disable)
- Bit5 (/WUP9H, PORT9 high nibble WAKE Up Enable) : used to enable the wake-up function of high nibble in PORT9, (1/0=enable/disable)
- Bit6 (/WDTE, Watch Dog Timer Enable)
Control bit used to enable Watchdog timer. (1/0=enable/disable)
- Bit7 unused

RF (Interrupt Status Register)

7	6	5	4	3	2	1	0
INT3	-	C8_2	C8_1	INT2	INT1	INT0	TCIF

- “1” means interrupt request, “0” means non-interrupt
- Bit 0 (TCIF) TCC timer overflow interrupt flag. Set when TCC timer overflows .
- Bit 1 (INT0) external INT0 pin interrupt flag .
- Bit 2 (INT1) external INT1 pin interrupt flag .
- Bit 3 (INT2) external INT2 pin interrupt flag .
- Bit 4 (C8_1) internal 8 bit counter interrupt flag .
- Bit 5 (C8_2) internal 8 bit counter interrupt flag .



- Bit 6 :unused. Please set to '0'.
- Bit 7 (INT3) external INT3 pin interrupt flag.
- High to low edge trigger , Refer to the Interrupt subsection.
- IOCF is the interrupt mask register. User can read and clear.

R10~R3F (General Purpose Register)

- R10~R3F (Banks 0~3) all are general purpose registers.

Special Purpose Registers

A (Accumulator)

- Internal data transfer, or instruction operand holding
- It's not an addressable register.

CONT (Control Register)

7	6	5	4	3	2	1	0
-	INT	TS	-	PAB	PSR2	PSR1	PSR0

- Bit 0 (PSR0) ~ Bit 2 (PSR2) TCC/WDT prescaler bits.

PSR2	PSR1	PSR0	TCC Rate	WDT Rate
0	0	0	1:2	1:1
0	0	1	1:4	1:2
0	1	0	1:8	1:4
0	1	1	1:16	1:8
1	0	0	1:32	1:16
1	0	1	1:64	1:32
1	1	0	1:128	1:64
1	1	1	1:256	1:128

- Bit 3 (PAB) Prescaler assignment bit
0/1: TCC/WDT
- Bit 4 unused
- Bit 5 (TS) : TCC signal source
0 : internal instruction cycle clock
1 : 16.38KHz
- **Bit 6 : (INT)INT enable flag**
0: interrupt masked by DISI or hardware interrupt
1: interrupt enabled by ENI/RETI instructions
- Bit 7 : unused
- CONT register is readable and writable.



IOC6 ~ IOC9 (I/O Port Control Register)

- Five I/O direction control registers.
- “1” put the relative I/O pin into high impedance, while “0” put the relative I/O pin as output.
- User can see IOCB register how to switch to normal I/O port.

IOCA (RAM,IO ,PAGE Control Register)(read/write,initial “00000000”)

7	6	5	4	3	2	1	0
P8SH	P8SL	0	CALL_4	CALL_3	CALL_2	CALL_1	0

• Bit0 unused

- Bit4~Bit1:”000” to “1001” are ten blocks of RAM area. User can use 2.5K RAM with RC ram address.
- Bit 5 unused
- Bit6: port8 low nibble switch, 0/1= normal I/O port/SEGMENT output .
- Bit7: port8 high nibble switch , 0/1= normal I/O port/SEGMENT output

IOCB (LCD ADDRESS)

PAGE0 : Bit6 ~ Bit0 = LCDA6 ~ LCDA0

The LCD display data is stored in the data RAM . The relation of data area and COM/SEG pin is as below:

COM15 ~ COM8	COM7 ~ COM0	
40H (Bit15 ~ Bit8)	00H (Bit7 ~ Bit0)	SEG0
41H	01H	SEG1
:	:	:
:	:	:
7BH	3BH	SEG59
7CH	3CH	Empty
7DH	3DH	Empty
7EH	3EH	Empty
7FH	3FH	Empty

PAGE1 : 8 bit up-counter (COUNTER1) preset and read out register . (write = preset) . After a interruption , it will count from “00”.

IOCC (LCD DATA)

PAGE0 : Bit7 ~ Bit0 = LCD RAM data register

PAGE1 : 8 bit up-counter (COUNTER2) preset and read out register. (write=preset) After a interruption, it will count from "00".

IOCD (Pull-high Control Register)

7	6	5	4	3	2	1	0
PH7	PH6	PH5	PH4	PH3	PH2	PH1	PH0

- Bit 0 ~ 7 (/PH#) Control bit used to enable the pull-high of PORT7(#) pin.

1: Enable internal pull-high

0: Disable internal pull high

7	6	5	4	3	2	1	0
P9SH	P9SL	P6S	Bias3	Bias2	Bias1	0	SC

- Bit 0 :SC (SCAN KEY signal) 0/1 = disable/enable. Once you enable this bit , all of the LCD signal will have a low pulse during a common period. This pulse has 30us width. Please use the procedure to implement the key scan function.
 - a. set port7 as input port
 - b. set IOCD page0 port7 pull high
 - c. enable scan key signal
 - d. Once push a key . Set RA(6)=1 and switch to normal mode.
 - e. **Blank** LCD. Disable scan key signal.
 - f. Set P6S =0. Port6 sent probe signal to port7 and read port7. Get the key.
 - g. Note!! A probe signal should delay a instruction at least to another probe signal.
 - h. Set P6S =1. Port6 as LCD signal. Enable LCD.

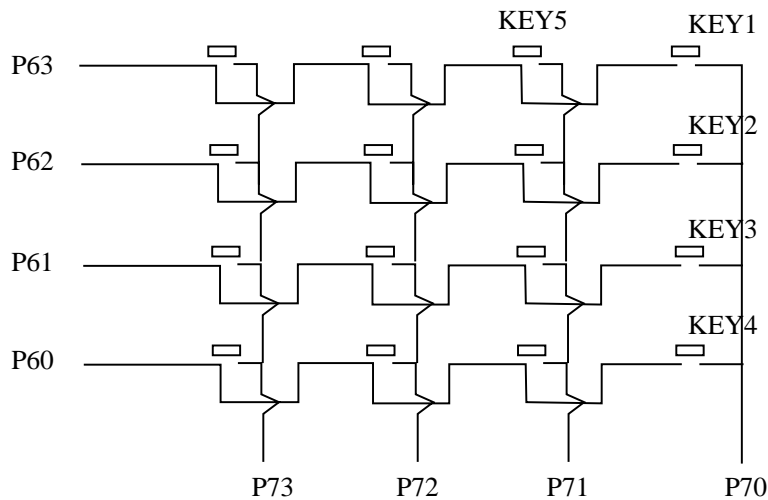

Fig.8. Key scan circuit

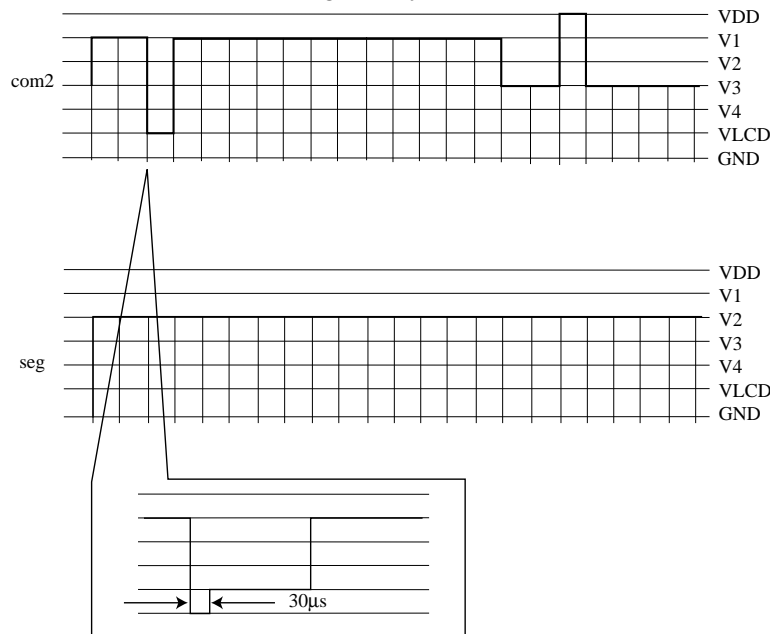

Fig.9. Key scan signal



- **Bit 1 : zero**
- Bit 2~4 (Bias1~Bias3) Control bits used to choose LCD operation voltage .

LCD operate voltage	Vop (VDD 5V)	VDD=5V
000	0.60VDD	3.0V
001	0.66VDD	3.3V
010	0.74VDD	3.7V
011	0.82VDD	4.0V
100	0.87VDD	4.4V
101	0.93VDD	4.7V
110	0.96VDD	4.8V
111	1.00VDD	5.0V

- Bit5:port6 switch , 0/1= normal I/O port/COMMON output
- Bit6:port9 low nibble switch , 0/1= normal I/O port/SEGMENT output . Bit7:port9 high nibble switch

PAGE1 :

7	6	5	4	3	2	1	0
OP77	OP76	C2S	C1S	PSC1	PSC0	-	-

- Bit0: unused, please set to '0'
- Bit1: unused, please set to '0'
- Bit3~Bit2: counter1 prescaler , reset=(0,0)
(PSC1,PSC0) = (0,0)=>1:1 , (0,1)=>1:2 , (1,0)=>1:4 , (1,1)=>1:8
- Bit4:counter1 source , (0/1)=(32768Hz/3.679MHz if enable)
- Bit5:counter2 source , (0/1)=(32768Hz/3.679MHz if enable) scale=1:1
- Bit6:P76 opendrain control (0/1)=(disable/enable)
- Bit7:P77 opendrain control (0/1)=(disable/enable)

IOCF (Interrupt Mask Register)

7	6	5	4	3	2	1	0
INT3	-	C8_2	C8_1	INT2	INT1	INT0	TCIF

- Bit 0 ~ 7 interrupt enable bit.
0: disable interrupt
1: enable interrupt
- IOCF Register is readable and writable.

It is very important to save ACC,R3 and R5 when processing a interruption.

Address	Instruction	Note
0x08	DISI	;Disable interrupt
0x09	MOV A_BUFFER,A	;Save ACC
0x0A	SWAP A_BUFFER	
0x0B	SWAPA 0x03	;Save R3 status
0x0C	MOV R3_BUFFER,A	
0x0D	MOV A,0x05	;Save ROM page register
0x0E	MOV R5_BUFFER,A	
:	:	
:	:	
:	MOV A,R5_BUFFER	;Return R5
:	MOV 0X05,A	
:	SWAPA R3_BUFFER	;Return R3
:	MOV 0X03,A	
:	SWAPA A_BUFFER	;Return ACC
:	RETI	

TCC/WDT Prescaler

There is an 8-bit counter available as prescaler for the TCC or WDT. The prescaler is available for the TCC only or WDT only at the same time.

- An 8 bit counter is available for TCC or WDT determined by the status of the bit 3 (PAB) of the CONT register.
- See the prescaler ratio in CONT register.
- Fig. 10 depicts the circuit diagram of TCC/WDT.
- Both TCC and prescaler will be cleared by instructions which write to TCC each time.
- The prescaler will be cleared by the WDTC and SLEP instructions, when assigned to WDT mode.
- **The prescaler will not be cleared by SLEP instructions, when assigned to TCC mode.**

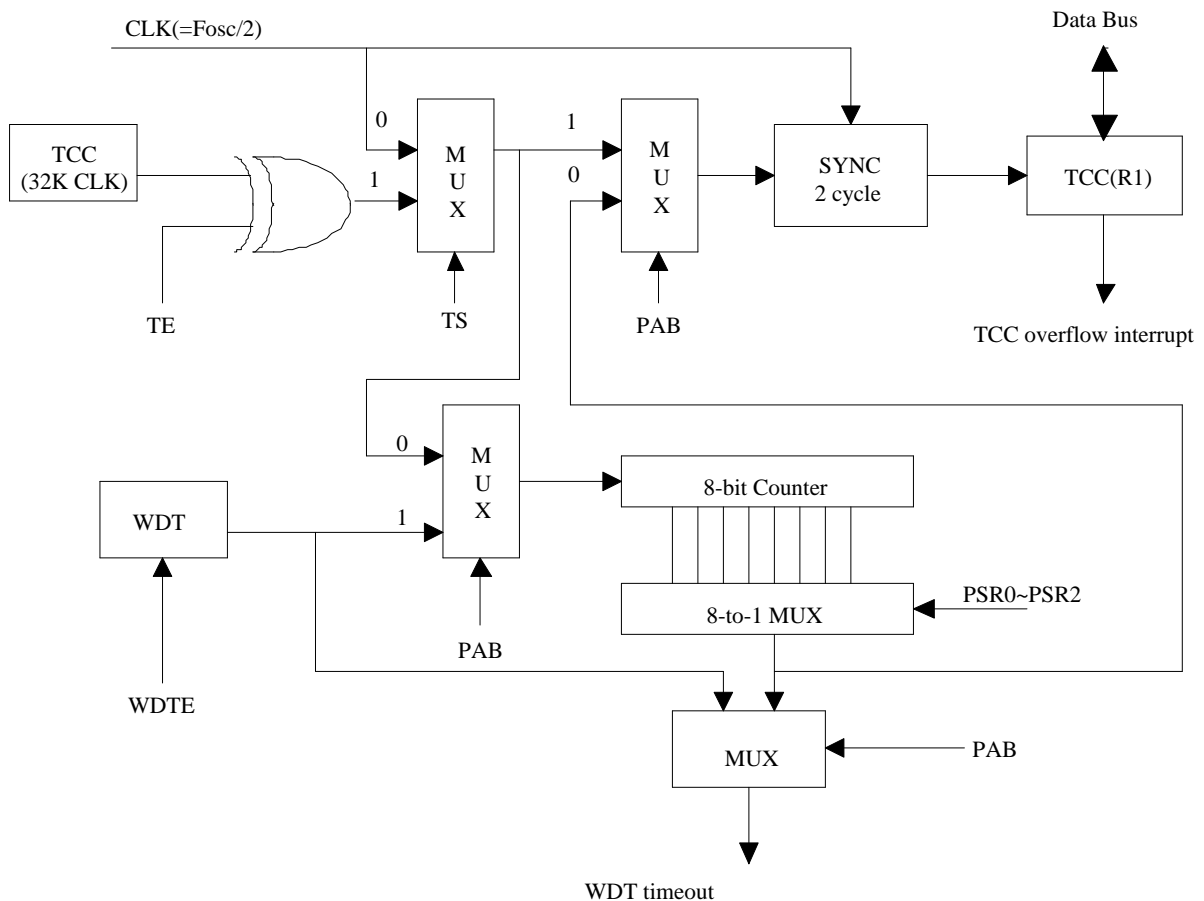

Fig. 10 Block diagram of TCC WDT

I/O Ports

The I/O registers, Port 6 ~ Port 9, are bi-directional tri-state I/O ports. Port 7 can be pulled-high internally by software control. The I/O ports can be defined as “input” or “output” pins by the I/O control registers (IOC6 ~ IOC9) under program control. The I/O registers and I/O control registers are both readable and writable. The I/O interface circuit is shown in Fig.11.

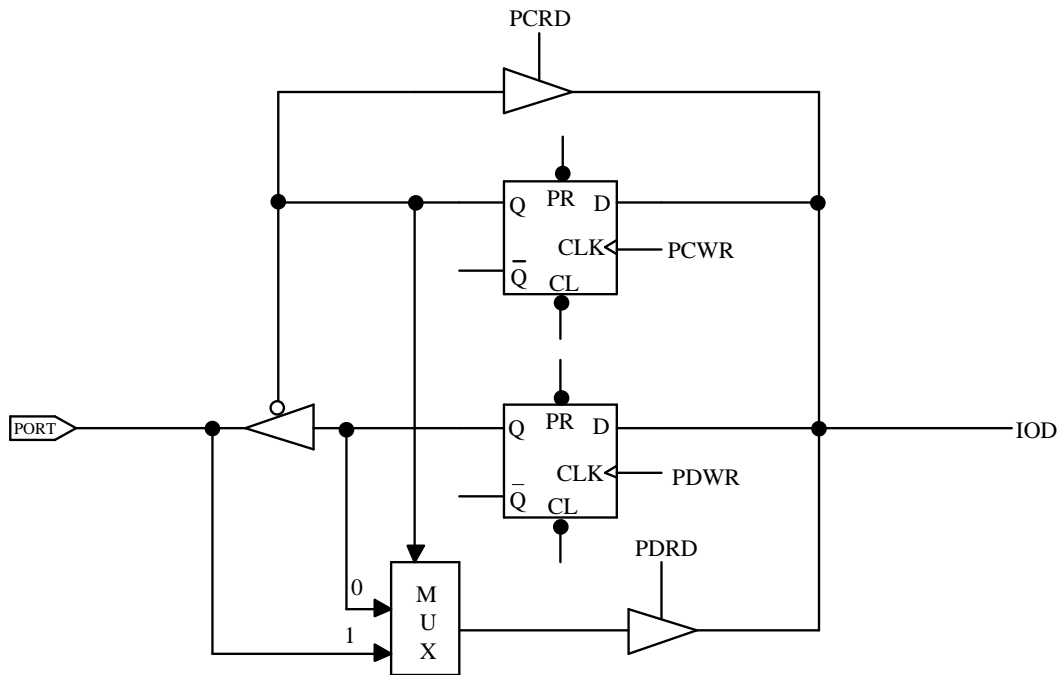

Fig. 11 The circuit of I/O port and I/O control register

RESET and Wake-up

The RESET can be caused by

- (1) Power on reset, or Voltage detector
- (2) WDT timeout. (if enabled and in GREEN or NORMAL mode)

Note that only Power on reset, or only Voltage detector in Case(1) is enabled in the system by CODE Option bit. If Voltage detector is disabled, Power on reset is selected in Case (1). Refer to Fig. 12.

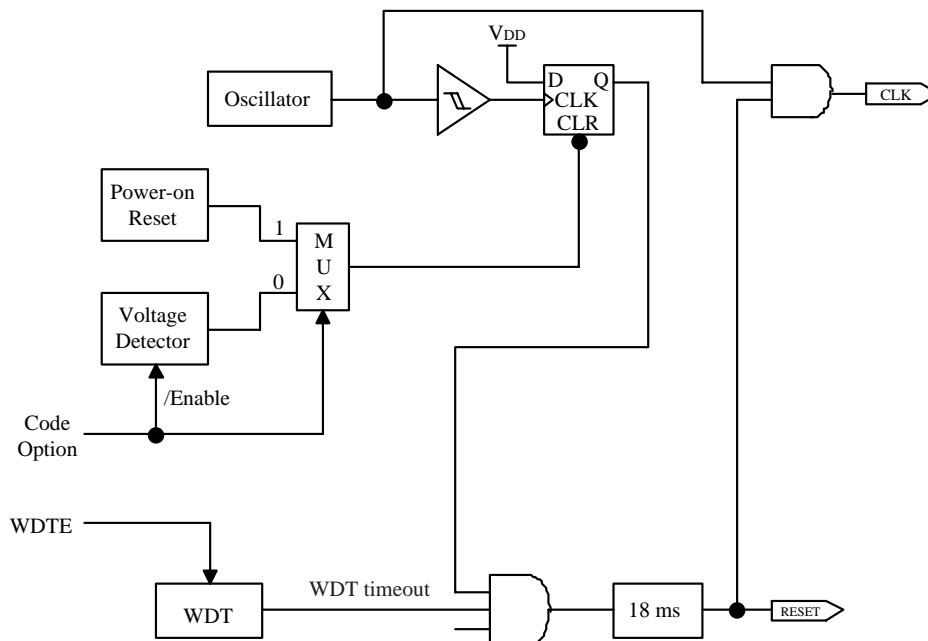

Fig. 12 Block diagram of Reset of controller



Once the RESET occurs, the following functions are performed.

- The oscillator is running, or will be started.
- The Program Counter (R2) is set to all “0”.
- When power on, the upper 3 bits of R3 and the upper 2 bits of R4 are cleared.
- The Watchdog timer and prescaler are cleared.
- The Watchdog timer is disabled.
- The CONT register is set to all “1”
- The other register (bit7..bit0)

R5 = “00000000”		
R6 = PORT	IOC6 = “11111111”	
R7 = PORT	IOC7 = “11111111”	
R8 = PORT	IOC8 = “11111111”	
R9 = PORT	IOC9 = “11111111”	
RA = “010x0xxx	IOCA = “00000000”	
RB = “11111111”	Page0 IOCB = “00000000”	Page1 IOCB = “00000000”
RC = “00000000”	Page0 IOCC = “0xxxxxxx”	Page1 IOCC = “00000000”
RD = “xxxxxxx”	Page0 IOCD = “00000000”	
RE = “00000000”	Page0 IOCE = “00000000”	Page1 IOCE = “00000000”
RF = “00000000”	IOCF = “00000000”	

The controller can be awakened from SLEEP mode or IDLE mode (execution of “SLEP” instruction, named as SLEEP MODE or IDLE mode) by (1)TCC time out (IDLE mode only) (2) WDT time-out (if enabled) or, (3) external input at PORT9 . The three cases will cause the controller wake up and run from next instruction in IDLE mode , reset in SLEEP mode . After wake-up , user should control WATCH DOG in case of reset in GREEN mode or NORMAL mode. The last two should be open RE register before into SLEEP mode or IDLE mode . The first one case will set a flag in RF bit0 . And it will go to address 0x08 when TCC generate a interrupt .

Interrupt

The chip has internal interrupts which are falling edge triggered, as followed : TCC timer overflow interrupt (internal) , two 8-bit counters overflow interrupt .

If these interrupt sources change signal from high to low , then RF register will generate ‘1’ flag to corresponding register if you enable IOCF register.

RF is the interrupt status register which records the interrupt request in flag bit. IOCF is the interrupt mask register. Global interrupt is enabled by ENI instruction and is disabled by DISI instruction. When one of the interrupts (when enabled) generated, will cause the next instruction to be fetched from address 008H. Once in the interrupt service routine the source of the interrupt can be determined by polling the flag bits in the RF register. The interrupt flag bit must be cleared in software before leaving the interrupt service routine and enabling interrupts to avoid recursive interrupts.

There are four external interrupt pins including INT0 , INT1 , INT2 , INT3 . And four internal counter interrupt available.

External interrupt INT0 , INT1 , INT2 , INT3 signals are from PORT7 bit0 to bit3 . If IOCF is enable then these signal will cause interrupt , or these signals will be treated as general input data .

After reset, the next instruction will be fetched from address 000H and the instruction inturrept is 001H and the hardware inturrept is 008H.

TCC will go to address 0x08 in GREEN mode or NORMAL mode after time out. And it will run next instruction from “SLEP” instruction and then go to address 0x08 in IDLE mode . These three cases will set a RF flag.



It is very important to save ACC,R3 and R5 when processing a interruption.

Address	Instruction	Note
0x08	DISI	;Disable interrupt
0x09	MOV A_BUFFER,A	;Save ACC
0x0A	SWAP A_BUFFER	
0x0B	SWAPA 0x03	;Save R3 status
0x0C	MOV R3_BUFFER,A	
0x0D	MOV A,0x05	;Save ROM page register
0x0E	MOV R5_BUFFER,A	
:	:	
:	:	
:	MOV A,R5_BUFFER	;Return R5
:	MOV 0X05,A	
:	SWAPA R3_BUFFER	;Return R3
:	MOV 0X03,A	
:	SWAPA A_BUFFER	;Return ACC
:	RETI	

Instruction Set

Instruction set has the following features:

- (1). Every bit of any register can be set, cleared, or tested directly.
- (2). The I/O register can be regarded as general register. That is, the same instruction can operates on I/O register. The symbol “R” represents a register designator which specifies which one of the 64 registers (including operational registers and general purpose registers) is to be utilized by the instruction. Bits 6 and 7 in R4 determine the selected register bank. “b” represents a bit field designator which selects the number of the bit, located in the register “R”, affected by the operation. “k” represents an 8 or 10-bit constant or literal value.

INSTRUCTION BINARY	HEX	MNEMONIC	OPERATION	STATUS AFFECTED
0 0000 0000 0000	0000	NOP	No Operation	None
0 0000 0000 0001	0001	DAA	Decimal Adjust A	C
0 0000 0000 0010	0002	CONTW	A CONT	None
0 0000 0000 0011	0003	SLEP	0 WDT, Stop oscillator	T,P
0 0000 0000 0100	0004	WDTC	0 WDT	T,P
0 0000 0000 rrrr	000r	IOW R	A IOCR	None
0 0000 0001 0000	0010	ENI	Enable Interrupt	None
0 0000 0001 0001	0011	DISI	Disable Interrupt	None
0 0000 0001 0010	0012	RET	[Top of Stack] PC	None
0 0000 0001 0011	0013	RETI	[Top of Stack] PC Enable Interrupt	None
0 0000 0001 0100	0014	CONTR	CONT A	None
0 0000 0001 rrrr	001r	IOR R	IOCR A	None
0 0000 0010 0000	0020	TBL	R2+A R2 bits 9,10 do not clear	Z,C,DC
0 0000 01rr rrrr	00rr	MOV R,A	A R	None
0 0000 1000 0000	0080	CLRA	0 A	Z
0 0000 11rr rrrr	00rr	CLR R	0 R	Z
0 0001 00rr rrrr	01rr	SUB A,R	R-A A	Z,C,DC
0 0001 01rr rrrr	01rr	SUB R,A	R-A R	Z,C,DC



INSTRUCTION BINARY				HEX	MNEMONIC	OPERATION	STATUS AFFECTED
0	0001	10rr	rrrr	01rr	DECA R	$R-1 \rightarrow A$	Z
0	0001	11rr	rrrr	01rr	DEC R	$R-1 \rightarrow R$	Z
0	0010	00rr	rrrr	02rr	OR A,R	$A \vee R \rightarrow A$	Z
0	0010	01rr	rrrr	02rr	OR R,A	$A \vee R \rightarrow R$	Z
0	0010	10rr	rrrr	02rr	AND A,R	$A \& R \rightarrow A$	Z
0	0010	11rr	rrrr	02rr	AND R,A	$A \& R \rightarrow R$	Z
0	0011	00rr	rrrr	03rr	XOR A,R	$A \oplus R \rightarrow A$	Z
0	0011	01rr	rrrr	03rr	XOR R,A	$A \oplus R \rightarrow R$	Z
0	0011	10rr	rrrr	03rr	ADD A,R	$A + R \rightarrow A$	Z,C,DC
0	0011	11rr	rrrr	03rr	ADD R,A	$A + R \rightarrow R$	Z,C,DC
0	0100	00rr	rrrr	04rr	MOV A,R	$R \rightarrow A$	Z
0	0100	01rr	rrrr	04rr	MOV R,R	$R \rightarrow R$	Z
0	0100	10rr	rrrr	04rr	COMA R	$\neg R \rightarrow A$	Z
0	0100	11rr	rrrr	04rr	COM R	$\neg R \rightarrow R$	Z
0	0101	00rr	rrrr	05rr	INCA R	$R+1 \rightarrow A$	Z
0	0101	01rr	rrrr	05rr	INC R	$R+1 \rightarrow R$	Z
0	0101	10rr	rrrr	05rr	DJZA R	$R-1 \rightarrow A$, skip if zero	None
0	0101	11rr	rrrr	05rr	DJZ R	$R-1 \rightarrow R$, skip if zero	None
0	0110	00rr	rrrr	06rr	RCCA R	$R(n) \rightarrow A(n-1)$ $R(0) \rightarrow C, C \rightarrow A(7)$	C
0	0110	01rr	rrrr	06rr	RRC R	$R(n) \rightarrow R(n-1)$ $R(0) \rightarrow C, C \rightarrow R(7)$	C
0	0110	10rr	rrrr	06rr	RLCA R	$R(n) \rightarrow A(n+1)$ $R(7) \rightarrow C, C \rightarrow A(0)$	C
0	0110	11rr	rrrr	06rr	RLC R	$R(n) \rightarrow R(n+1)$ $R(7) \rightarrow C, C \rightarrow R(0)$	C
0	0111	00rr	rrrr	07rr	SWAPA R	$R(0-3) \rightarrow A(4-7)$ $R(4-7) \rightarrow A(0-3)$	None
0	0111	01rr	rrrr	07rr	SWAP R	$R(0-3) \leftrightarrow R(4-7)$	None
0	0111	10rr	rrrr	07rr	JZA R	$R+1 \rightarrow A$, skip if zero	None
0	0111	11rr	rrrr	07rr	JZ R	$R+1 \rightarrow R$, skip if zero	None
0	100b	bbrr	rrrr	0xxx	BC R,b	$0 \rightarrow R(b)$	None
0	101b	bbrr	rrrr	0xxx	BS R,b	$1 \rightarrow R(b)$	None
0	110b	bbrr	rrrr	0xxx	JBC R,b	if $R(b)=0$, skip	None
0	111b	bbrr	rrrr	0xxx	JBS R,b	if $R(b)=1$, skip	None
1	00kk	kkkk	kkkk	1kkk	CALL k	$PC+1 \rightarrow [SP]$ (Page, k) $\rightarrow PC$	None
1	01kk	kkkk	kkkk	1kkk	JMP k	(Page, k) $\rightarrow PC$	None
1	1000	kkkk	kkkk	18kk	MOV A,k	$k \rightarrow A$	None
1	1001	kkkk	kkkk	19kk	OR A,k	$A \vee k \rightarrow A$	Z
1	1010	kkkk	kkkk	1Akk	AND A,k	$A \& k \rightarrow A$	Z
1	1011	kkkk	kkkk	1Bkk	XOR A,k	$A \oplus k \rightarrow A$	Z
1	1100	kkkk	kkkk	1Ckk	RETL k	$k \rightarrow A, [Top\ of\ Stack] \rightarrow PC$	None
1	1101	kkkk	kkkk	1Dkk	SUB A,k	$k - A \rightarrow A$	Z,C,DC
1	1110	0000	0001	1E01	INT	$PC+1 \rightarrow [SP]$ $001H \rightarrow PC$	None
1	1110	1000	kkkk	1E8k	PAGE k	$K \rightarrow R5$	None
1	1111	kkkk	kkkk	1Fkk	ADD A,k	$k + A \rightarrow A$	Z,C,DC

CODE Option Register

The chip has one CODE option register which is not part of the normal program memory. The option bits cannot be accessed during normal program execution.

7	6	5	4	3	2	1	0
-	-	-	-	-	-	/POVD	-

- Bit 0 : unused
- Bit 1 (/POVD) : Power on voltage detector.
0 : enable
1 : disable

/POVD	1.8V reset	power on reset	3.6V detect no reset	3.6V detect control by RA(5)	sleep mode current
1	no	yes	yes	yes	1μA
0	yes	yes	yes	yes	15μA

- Bit 2~7 : unused, must be "0"s.

LCD Driver

The chip can drive LCD directly and has 60 segments and 16 commons that can drive 60*16 dots totally. LCD block is made up of LCD driver , display RAM, segment output pins , common output pins and LCD operating power supply pins.

Duty , bias , the number of segment , the number of common and frame frequency are determined by LCD mode register . LCD control register .

The basic structure contains a timing control which uses the basic frequency 32.768KHz to generate the proper timing for different duty and display access. RE register is a command register for LCD driver, the LCD display (disable, enable, blanking) is controlled by LCD_C and the driving duty and bias is decided by LCD_M and the display data is stored in data RAM which address and data access controlled by registers RC and RD.

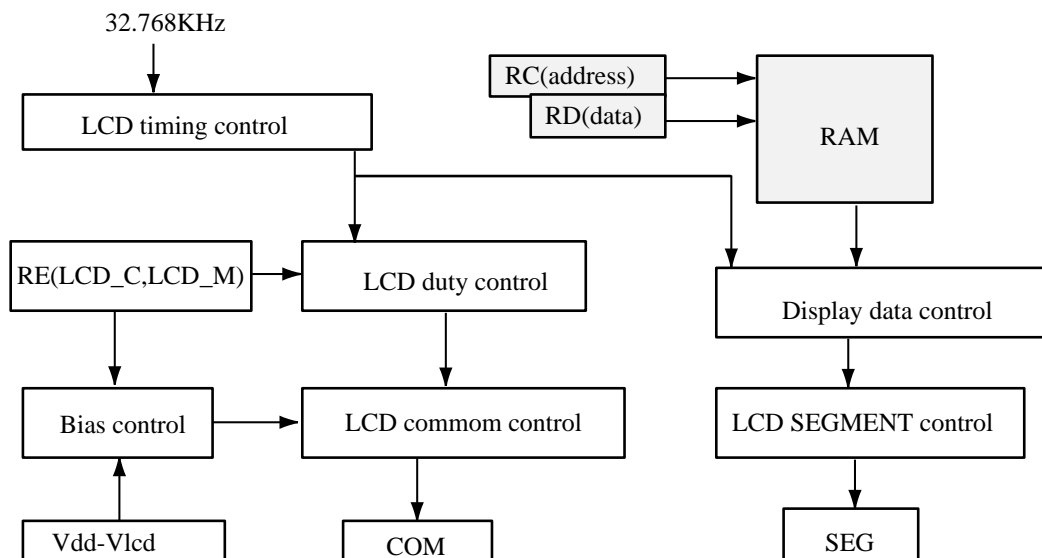

Fig13. LCD DRIVER CONTROL



LCD Driver Control

RE(LCD Driver Control)(initial state “00000000”)

7	6	5	4	3	2	1	0
-	-	-	-	-	LCD_C2	LCD_C1	LCD_M

- Bit0 (LCD_M):LCD_M decides the methods, including duty, bias, and frame frequency.
- Bit1~Bit2 (LCD_C#):LCD_C# decides the LCD display enable or blanking. change the display duty must set the LCD_C to “00”.

LCD_C2,LCD_C1	LCD Display Control	LCD_M	duty	bias
0 0	change duty Disable(turn off LCD)	0 1	1/16 1/8	1/4 1/4
0 1	Blanking	:	:	:
1 1	LCD display enable	:	:	:

LCD display area

The LCD display data is stored in the data RAM . The relation of data area and COM/SEG pin is as below:

COM15 ~ COM8	COM7 ~ COM0	
40H (Bit15 ~ Bit8)	00H (Bit7 ~ Bit0)	SEG0
41H	01H	SEG1
:	:	:
:	:	:
7BH	3BH	SEG59
7CH	3CH	empty
7DH	3DH	empty
7EH	3EH	empty
7FH	3FH	empty

- IOCB(LCD Display RAM address)

7	6	5	4	3	2	1	0
-	LCDA6	LCDA5	LCDA4	LCDA3	LCDA2	LCDA1	LCDA0

Bit 0 ~ Bit 6 select LCD Display RAM address up to 120.

LCD RAM can be write whether in enable or disable mode and read only in disable mode.

- IOCC(LCD Display data) : Bit 0 ~ Bit 8 are LCD data.

LCD COM and SEG signal

- COM signal : The number of COM pins varies according to the duty cycle used, as following: in 1/8 duty mode COM8 ~ COM15 must be open. in 1/16 duty mode COM0 ~ COM15 pins must be used.

	COM0	COM1	COM2	COM3	COM4	COM5	COM6	COM7	COM8	..	COM15
1/8	o	o	o	o	o	o	o	o	x	..	x
1/16	o	o	o	o	o	o	o	o	o	..	o

x:open,o:select

- **SEG signal:** The 60 segment signal pins are connected to the corresponding display RAM address 00h to 3Bh. The high byte and the low byte bit7 down to bit0 are correlated to COM15 to COM0 respectively . When a bit of display RAM is 1, a select signal is sent to the corresponding segment pin, and when the bit is 0 , a non-select signal is sent to the corresponding segment pin.
- COM, SEG and Select/Non-select signal is shown as following:

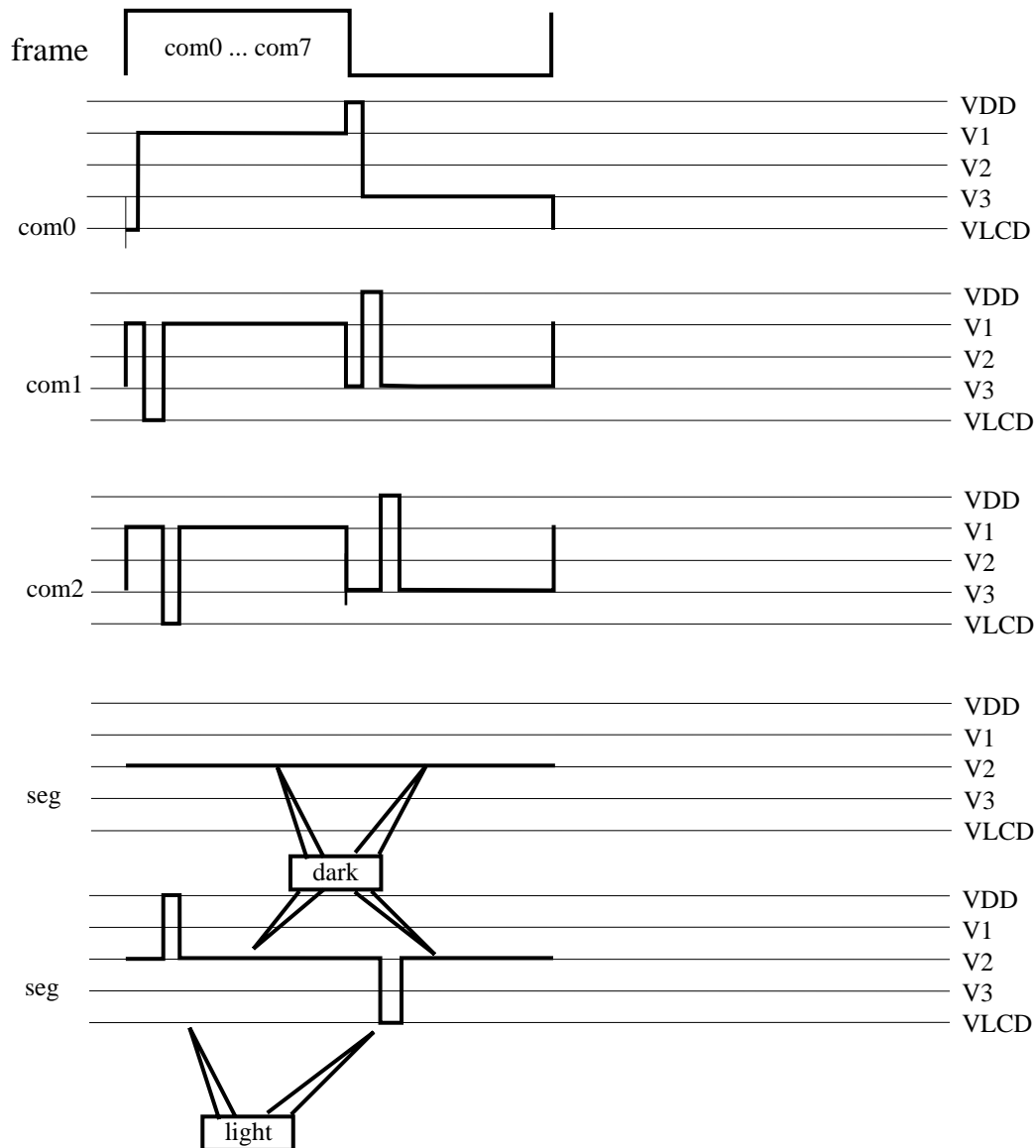

Fig.14 Lcd wave 1/4 bias, 1/8 duty

LCD Bias control

IOCE (Bias Control Register)

7	6	5	4	3	2	1	0
			Bias3	Bias2	Bias1		

Bit 2~4 (Bias1~Bias3) Control bits used to choose LCD operation voltage .

LCD operate voltage	Vop (VDD 5V)	VDD=5V
000	0.60 V _{DD}	3.0 V
001	0.66 V _{DD}	3.3 V
010	0.74 V _{DD}	3.7 V
011	0.82 V _{DD}	4.0 V
100	0.87 V _{DD}	4.4 V
101	0.93 V _{DD}	4.7 V
110	0.96 V _{DD}	4.8 V
111	1.00 V _{DD}	5.0 V

- Bit 5~7 unused

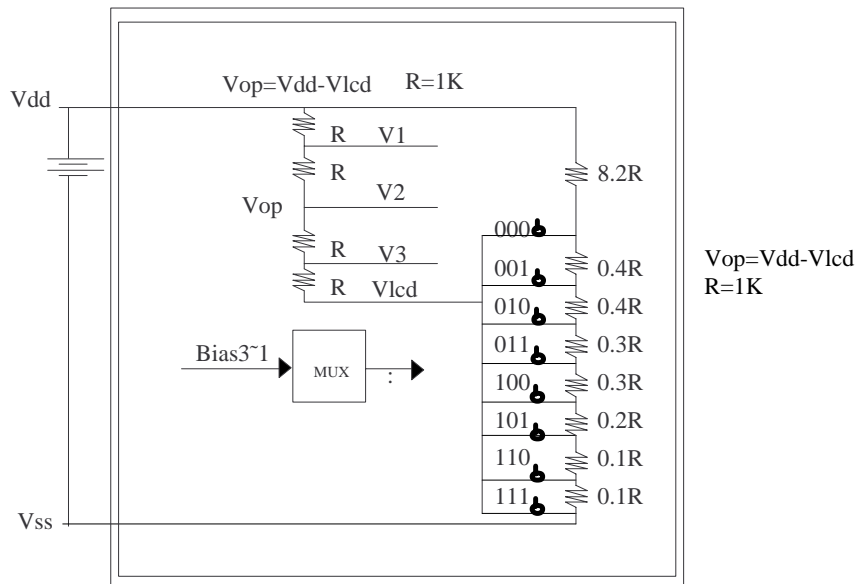

Fig.16 LCD bias circuit



ABSOLUTE MAXIMUM RATINGS

Items	Sym.	Condition	Rating	Unit
Temperature under bias	V_{DD}		-0.3 to 6	V
Input voltage	V_{IN}		- 0.5 to $V_{DD} + 0.5$	V
Operating temperature range	T_A		0 to 70	°C

DC ELECTRICAL CHARACTERISTICS

($T_A = 0^{\circ}\text{C} \sim 70^{\circ}\text{C}$, $V_{DD} = 5\text{V} \pm 5\%$; $V_{SS} = 0\text{V}$)

Parameter	Sym.	Condition	Min.	Typ.	Max.	Unit
Input Leakage Current for input pins	I_{IL1}	$V_{IN} = V_{DD}, V_{SS}$			± 1	μA
Input Leakage Current for bi-directional pins	I_{IL2}	$V_{IN} = V_{DD}, V_{SS}$			± 1	μA
Input High Voltage	V_{IH}		2.5			V
Input Low voltage	V_{IL}				0.8	V
Input High Threshold Voltage	V_{IHT}	$\overline{\text{RESET}}, \text{TCC}, \text{RDET1}$	2.0			V
Input Low Threshold Voltage	V_{ILT}	$\overline{\text{RESET}}, \text{TCC}, \text{RDET1}$			0.8	V
Clock Input High Voltage	V_{IHx}	OSCI	3.5			V
Clock Input Low Voltage	V_{ILx}	OSCI			1.5	V
Key scan Input High Voltage	VHscan	Port6 for key scan	3.5			V
Key scan Input Low Voltage	VLscan	Port6 for key scan			1.5	V
Output High Voltage (port5,6,7,8)	V_{OH1}	$I_{OH} = \pm 1.6 \text{ mA}$	2.4			V
(port9)		$I_{OH} = \pm 6 \text{ mA}$	2.4			V
Output Low Voltage (port5,6,7,8)	V_{OL1}	$I_{OL} = \pm 1.6 \text{ mA}$			0.4	V
(port9)		$I_{OL} = \pm 6 \text{ mA}$			0.4	V
Com Voltage drop	V_{COM}	$I_O = \pm 50 \mu\text{A}$	-	-	2.9	V
Segment Voltage drop	V_{SEG}	$I_O = \pm 50 \mu\text{A}$	-	-	3.8	V
LCD Drive Reference Voltage	V_{LCD}	Contrast adjustment				
Pull-high Current	I_{PH}	Pull-high active input pin at V_{SS}	-50	-100	-240	μA
Power Down Current	I_{SB1}	All input and I/O pin at V_{DD} , output pin floating, WDT disabled			3	μA
IDLE mode current	I_{SB-1}	All input and I/O pin at V_{DD} , output pin floating, WDT disabled, LCD enable			80	μA
Low Clock Current	I_{SB2}	CLK=32.768 KHz, All input and I/O pin at V_{DD} , output pin floating, WDT disabled, LCD enable			90	μA
Operating Supply Current	I_{CC}	$\overline{\text{RESET}}=\text{HIGH}$, CLK=3.679MHz, output pin floating			1.5	mA



AC ELECTRICAL CHARACTERISTIC ($T_A = 0 \sim 70^\circ\text{C}$, $V_{DD} = 5\text{V}$, $V_{SS} = 0\text{V}$)

Parameter	Sym.	Condition	Min.	Typ.	Max.	Unit
Input CLK duty cycle	Dclk		45	50	55	%
Instruction cycle time	Tins	32.768K		60		μs
		3.679M		550		μs
Device delay hold time	Tdrh			18		ms
TCC input period	Ttcc	Note 1	$(T_{in}+20)/N$			ns
Watchdog timer period	Twdt	$T_A = 25^\circ\text{C}$		18		ms

Note 1: N = selected prescaler ratio.

TIMING DIAGRAMS

AC Test Input/Output Waveform

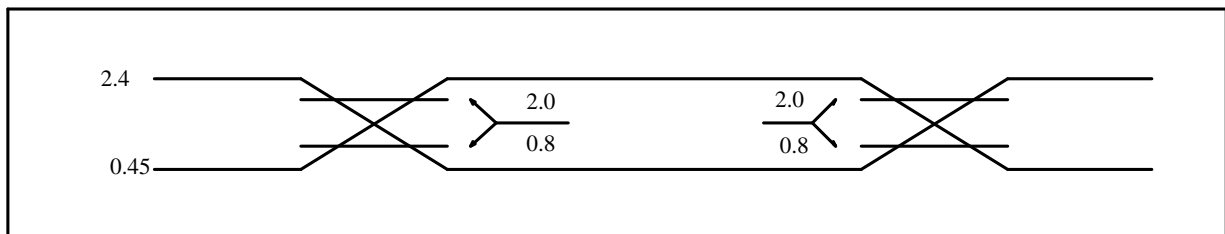

AC Testing : Input are driven at 2.4V for logic "1", and 0.45V for logic "0". Timing measurements are made at 2.0V for logic "1", and 0.8V for logic "0".

RESET Timing

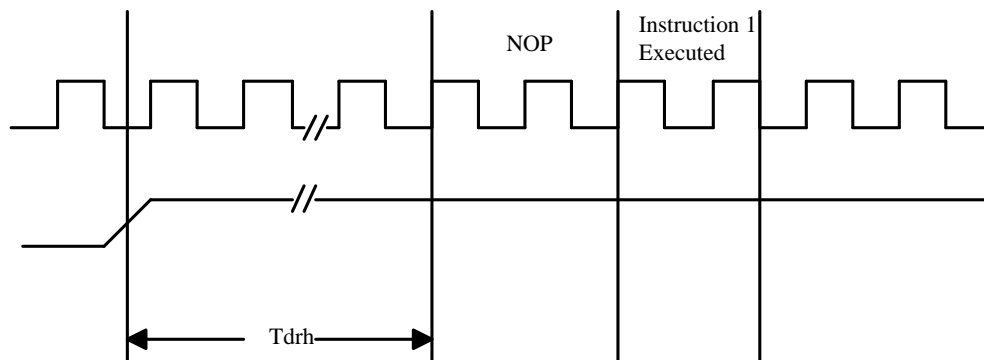

TCC Input Timing

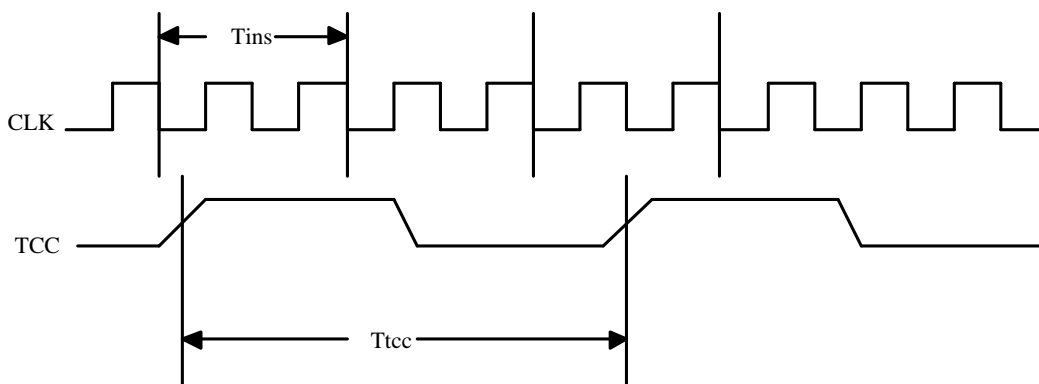

Fig.17 AC timing



APPLICATION CIRCUIT

