



# EMC1053

## 1°C Triple Temperature Sensor with Resistance Error Correction and Hotter of Two Zones

### PRODUCT FEATURES

Datasheet

#### GENERAL DESCRIPTION

The EMC1053 is a System Management Bus (SMBus) temperature sensor that monitors up to three temperature zones, two remote and one local, for PC and embedded environments. The EMC1053 extended features include resistance error correction and ideality factor configuration to eliminate major sources of temperature measurement error.<sup>1</sup> Monitoring both diodes of a dual-core CPU is simplified with the Hotter of Two Zones feature.

The external and internal measurement ranges support two data ranges (and formats), -64°C to +127°C and -64°C to +191°C.

Selectable conversion rates and standby mode support low-power operation.

#### APPLICATIONS

- Desktop and Notebook Computers
- Hardware Management

#### FEATURES

- Resistance Error Correction
- Ideality Factor Configuration
- Reports Hotter of Two Zones with dual-core CPU
- Accepts 2200pF cap for noise suppression
- 2 Remote Thermal Zones
  - ±1°C Accuracy (40°C to 80°C)
  - 0.125°C resolution
- Internal Thermal Zone
  - ±3°C Accuracy (0°C to 85°C)
  - 0.125°C resolution
- Low Power; 3.0V to 3.6V Supply
- Programmable Conversion Rate
- SMBus 2.0 Compliant

1.Patents pending.

### SIMPLIFIED BLOCK DIAGRAM

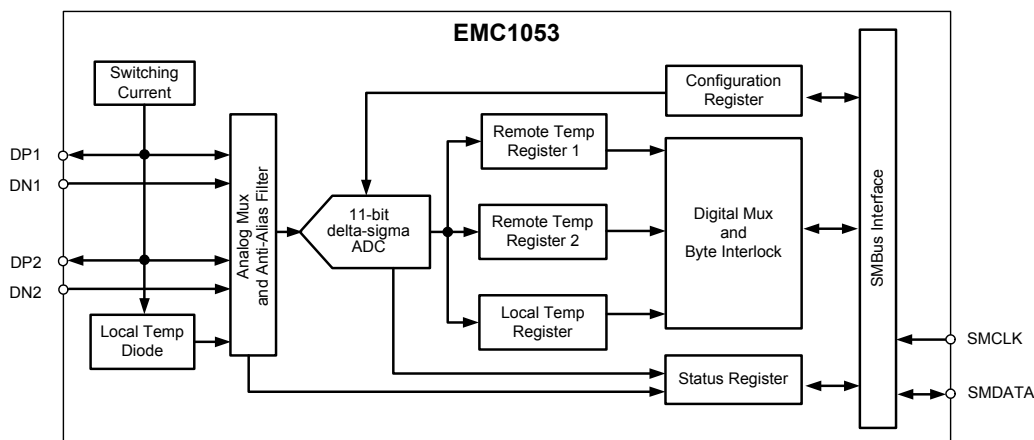

**ORDER NUMBERS****EMC1053-ACZL-TR FOR 8 PIN, MSOP PACKAGE (ADDRESS - 1001100B) (GREEN, LEAD-FREE)****REEL SIZE IS 4,000 PIECES.****EVALUATION BOARD AVAILABLE UPON REQUEST. (EVB-EMC1053)**

80 Arkay Drive  
Hauppauge, NY 11788  
(631) 435-6000  
FAX (631) 273-3123

Copyright © 2005 SMSC or its subsidiaries. All rights reserved.

Circuit diagrams and other information relating to SMSC products are included as a means of illustrating typical applications. Consequently, complete information sufficient for construction purposes is not necessarily given. Although the information has been checked and is believed to be accurate, no responsibility is assumed for inaccuracies. SMSC reserves the right to make changes to specifications and product descriptions at any time without notice. Contact your local SMSC sales office to obtain the latest specifications before placing your product order. The provision of this information does not convey to the purchaser of the described semiconductor devices any licenses under any patent rights or other intellectual property rights of SMSC or others. All sales are expressly conditional on your agreement to the terms and conditions of the most recently dated version of SMSC's standard Terms of Sale Agreement dated before the date of your order (the "Terms of Sale Agreement"). The product may contain design defects or errors known as anomalies which may cause the product's functions to deviate from published specifications. Anomaly sheets are available upon request. SMSC products are not designed, intended, authorized or warranted for use in any life support or other application where product failure could cause or contribute to personal injury or severe property damage. Any and all such uses without prior written approval of an Officer of SMSC and further testing and/or modification will be fully at the risk of the customer. Copies of this document or other SMSC literature, as well as the Terms of Sale Agreement, may be obtained by visiting SMSC's website at <http://www.smisc.com>. SMSC is a registered trademark of Standard Microsystems Corporation ("SMSC"). Product names and company names are the trademarks of their respective holders.

**SMSC DISCLAIMS AND EXCLUDES ANY AND ALL WARRANTIES, INCLUDING WITHOUT LIMITATION ANY AND ALL IMPLIED WARRANTIES OF MERCHANTABILITY, FITNESS FOR A PARTICULAR PURPOSE, TITLE, AND AGAINST INFRINGEMENT AND THE LIKE, AND ANY AND ALL WARRANTIES ARISING FROM ANY COURSE OF DEALING OR USAGE OF TRADE. IN NO EVENT SHALL SMSC BE LIABLE FOR ANY DIRECT, INCIDENTAL, INDIRECT, SPECIAL, PUNITIVE, OR CONSEQUENTIAL DAMAGES; OR FOR LOST DATA, PROFITS, SAVINGS OR REVENUES OF ANY KIND; REGARDLESS OF THE FORM OF ACTION, WHETHER BASED ON CONTRACT; TORT; NEGLIGENCE OF SMSC OR OTHERS; STRICT LIABILITY; BREACH OF WARRANTY; OR OTHERWISE; WHETHER OR NOT ANY REMEDY OF BUYER IS HELD TO HAVE FAILED OF ITS ESSENTIAL PURPOSE, AND WHETHER OR NOT SMSC HAS BEEN ADVISED OF THE POSSIBILITY OF SUCH DAMAGES.**

## Chapter 1 Pin Function

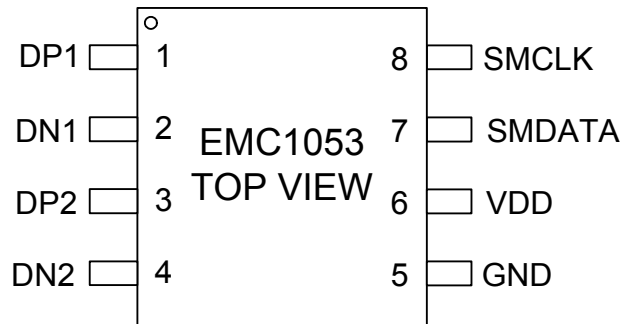

**Figure 1.1 Pin Diagram**

**Table 1.1 Pin Description**

PIN	PIN NO.	DESCRIPTION
DP1	1	Positive Analog Input for Remote Temperature Diode 1
DN1	2	Negative Analog Input for Remote Temperature Diode 1
DP2	3	Positive Analog Input for Remote Temperature Diode 2
DN2	4	Negative Analog Input for Remote Temperature Diode 2
GND	5	Ground
VDD	6	Supply Voltage
SMDATA	7	System Management Bus Data Input/Output, open drain output
SMCLK	8	System Management Bus Clock Input

## Chapter 2 Electrical Specifications

### 2.1 Absolute Maximum Ratings

**Table 2.1 Absolute Maximum Ratings**

DESCRIPTION	RATING	UNIT
Supply Voltage $V_{DD}$	-0.3 to 5.0	V
Voltage on SMDATA and SMCLK pins	-0.3 to 5.5	V
Voltage on any other pin	-0.3 to $V_{DD}+0.3$	V
Operating Temperature Range	0 to 85	°C
Storage Temperature Range	-55 to 150	°C
Lead Temperature Range	Refer to JEDEC Spec. J-STD-020	
Package Thermal Characteristics for MSOP-8		
Power Dissipation	TBD	
Thermal Resistance (at 0 air flow)	135.9	°C/W
ESD Rating, All Pins Human Body Model	2000	V

**Note:** Stresses above those listed could cause damage to the device. This is a stress rating only and functional operation of the device at any other condition above those indicated in the operation sections of this specification is not implied. When powering this device from laboratory or system power supplies, it is important that the Absolute Maximum Ratings not be exceeded or device failure can result. Some power supplies exhibit voltage spikes on their outputs when the AC power is switched on or off. In addition, voltage transients on the AC power line may appear on the DC output. If this possibility exists, it is suggested that a clamp circuit be used.

### 2.2 Electrical Specifications

**Table 2.2 Electrical Characteristics**

$V_{DD}=3.0V$ to $3.6V$ , $T_A=0^{\circ}C$ to $+85^{\circ}C$ , Typical values at $T_A=27^{\circ}C$ unless otherwise noted						
PARAMETER	SYMBOL	MIN	TYP	MAX	UNITS	CONDITIONS
<b>DC Power</b>						
Supply Voltage	$V_{DD}$	3.0	3.3	3.6	V	
Average Operating Current	$I_{DD}$		340	375	$\mu A$	4 conversions/s See <a href="#">Table 4.6</a> .
	$I_{STBY}$		2	4	$\mu A$	Standby mode
<b>Internal Temperature Monitor</b>						
Temperature Accuracy			$\pm 1$	$\pm 3$	°C	$0^{\circ}C \leq T_A \leq 85^{\circ}C$
Temperature Resolution			0.125		°C	

## Datasheet

Table 2.2 Electrical Characteristics (continued)

V <sub>DD</sub> =3.0V to 3.6V, T <sub>A</sub> = 0°C to +85°C, Typical values at T <sub>A</sub> = 27°C unless otherwise noted						
PARAMETER	SYMBOL	MIN	TYP	MAX	UNITS	CONDITIONS
<b>External Temperature Monitor</b>						
Temperature Accuracy Remote Diode 40°C to 80°C Remote Diode 0°C to 125°C				± 1 ± 3	°C °C	15°C ≤ T <sub>A</sub> ≤ 70°C 0°C ≤ T <sub>A</sub> ≤ 85°C
Temperature Resolution			0.125		°C	
Capacitive Load	C <sub>LOAD</sub>			2.5	nF	Connected across remote diode.
<b>Voltage Tolerance</b>						
Voltage at pin ( SMDATA,SMCLK)	V <sub>TOL</sub>	-0.3		5.5	V	
<b>SMBus Interface (SMDATA,SMCLK)</b>						
Input High Level	V <sub>IH</sub>	2.0			V	
Input Low Level	V <sub>IL</sub>			0.8	V	
Input High/Low Current	I <sub>IH</sub> /I <sub>IL</sub>	-1		1	μA	
Hysteresis			500		mV	
Input Capacitance			5		pF	
Output Low Sink Current		6			mA	SMDATA = 0.6V
<b>SMBus Timing</b>						
Clock Frequency	F <sub>SMB</sub>	10		400	kHz	
Spike Suppression				50	ns	
Bus free time Start to Stop	T <sub>BUF</sub>	1.3			μs	
Hold time Start	T <sub>HD:STA</sub>	0.6			μs	
Setup time Start	T <sub>SU:STA</sub>	0.6			μs	
Setup time Stop	T <sub>SU:STO</sub>	0.6			μs	
Data Hold Time	T <sub>HD:DAT</sub>	0.3			μs	
Data Setup Time	T <sub>SU:DAT</sub>	100			ns	
Clock Low Period	T <sub>LOW</sub>	1.3			μs	
Clock High Period	T <sub>HIGH</sub>	0.6			μs	
Clock/Data Fall Time	T <sub>F</sub>	*		300	ns	*Min = 20+0.1C <sub>b</sub> ns
Clock/Data Rise Time	T <sub>R</sub>	*		300 Note 2.1	ns	*Min = 20+0.1C <sub>b</sub> ns
Capacitive Load (each bus line)	C <sub>b</sub>	0.6		400	pF	

**Note 2.1** 300nS rise time max is required for 400kHz bus operation. For lower clock frequencies, the maximum rise time is (0.1/F<sub>SMB</sub>)+50nS

## 2.3 System Management Bus Interface Protocol

A host controller, such as an SMSC I/O controller, communicates with the EMC1053 via the two wire serial interface named SMBus. The SMBus interface is used to read and write registers in the EMC1053, which is a slave-only device. A detailed timing diagram is shown in [Figure 2.1](#).

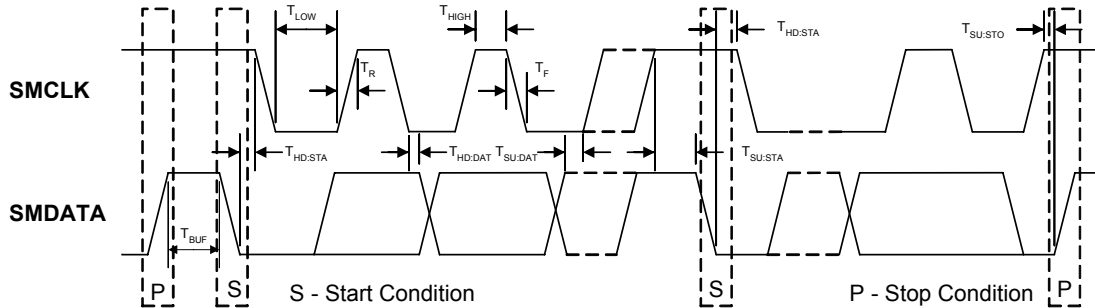

**Figure 2.1 System Management Bus Timing Diagram**

The EMC1053 implements a subset of the SMBus specification and supports Write Byte, Read Byte, Send Byte, and Receive Byte protocols as shown. In the tables that describe the protocol, the “gray” columns indicate that the slave is driving the bus.

All of the below protocols use the following convention:

DATA SENT TO DEVICE	DATA SENT TO THE HOST
# of bits sent	# of bits sent

### 2.3.1 Write Byte

The Write Byte is used to write one byte of data to the registers as shown in [Table 2.3](#).

**Table 2.3 Write Byte Protocol**

START	SLAVE ADDRESS	WR	ACK	COMMAND	ACK	DATA	ACK	STOP
1	7	1	1	8	1	8	1	1

### 2.3.2 Read Byte

The Read Byte protocol is used to read one byte of data from the registers as shown in [Table 2.4](#).

**Table 2.4 Read Byte Protocol**

START	SLAVE ADDRESS	WR	ACK	COMMAND	ACK	START	SLAVE ADDRESS	RD	ACK	DATA	NACK	STOP
1	7	1	1	8	1	1	7	1	1	8	1	1

### 2.3.3 Send Byte

The Send Byte protocol is used to set the Internal Address Register to the correct Address as shown in [Table 2.5](#). The Send Byte can be followed by the Receive Byte protocol described in [Table 2.6](#) to

**Datasheet**

read data from the register. The send byte protocol cannot be used to write data - if data is to be written to a register then the write byte protocol must be used as described in [Section 2.3.1](#).

**Table 2.5 Send Byte Protocol**

START	SLAVE ADDR	WR	ACK	REG. ADDR	ACK	STOP
1	7	1	1	8	1	1

**2.3.4 Receive Byte**

The Receive Byte protocol is used to read data from a register when the internal register address pointer is known to be at the right location (e.g. set via Send Byte). This can be used for consecutive reads of the same register as shown in [Table 2.6](#).

**Table 2.6 Receive Byte Protocol**

START	SLAVE ADDR	RD	ACK	REG. DATA	NACK	STOP
1	7	1	1	8	1	1

**2.3.5 SMBus Timing Diagram**

The Timing for the SMBus is shown in [Figure 2.1](#).

**2.4 SMBus Addresses**

The EMC1053 may be ordered with one of the 7-bit slave addresses as shown in [Order Numbers](#). Attempting to communicate with the EMC1053 SMBus interface with an invalid slave address or invalid protocol results in no response from the device and does not affect its register contents. The EMC1053 supports stretching of the SMCLK signal by other devices on the SMBus but will not perform this operation itself.

**2.5 SMBus Timeout**

The EMC1053 includes an SMBus timeout feature. Following a 25 ms period of inactivity on the SMBus, the device will timeout and reset the SMBus interface.

## Chapter 3 Product Description

The EMC1053 is an SMBus sensor that is capable of monitoring three temperature zones for use in a personal computer or embedded environment. The part may be used as a companion to one of SMSC's broad line of SIO host circuits, or other devices capable of performing the SMBus host function. A typical system overview is shown in [Figure 3.1](#).

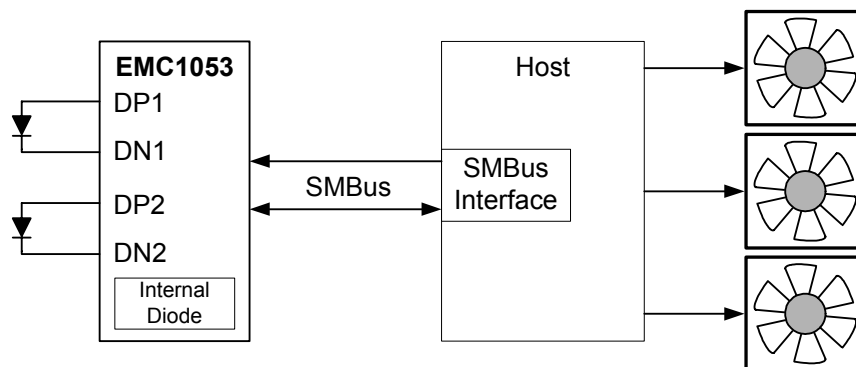

**Figure 3.1 EMC1053 System Overview**

### 3.1 Power Modes

The EMC1053 has two power modes as defined here:

- Run Mode - In this mode, the temperature monitors are active and converting at various conversion rates. The average power dissipation will depend on the conversion rate. When the EMC1053 is not actively converting a channel, it goes into a lower power wait state where only the oscillator is running.
- Standby Mode- in this mode, the EMC1053 is put into a low power state drawing a maximum current of 3uA. The SMBus is still operating in standby and a one-shot command may be given which forces the part to Run Mode temporarily for 1 full set of temperature conversions. The EMC1053 returns to standby after the one shot conversion is completed.

### 3.2 One Shot During Standby Mode

The EMC1053 supports a One-Shot command when it is in Standby Mode. Writing to the One-Shot register will cause the device to power up and perform 1 full set of temperature conversions according to the selected conversion rate, and then return to the Standby Mode.

### 3.3 Operation During Run Mode

When the device is active, there are two modes of operation available.

- Normal Mode - In this mode, the EMC1053 continuously samples and updates all of its temperature channels. In this mode of operation, each data channel is measured and loaded into the appropriate data registers normally.
- Hotter of Two Mode - In this mode, the EMC1053 continuously samples and then compares the two remote zones. The hotter of the two remote zones is loaded into the External Diode 2 data registers. In addition, the HOTTER bit in the Status register is set or cleared to indicate which external diode zone was hotter. If the two external zones are exactly equal to each other, then the



## Datasheet

HOTTER bit is cleared (set to '0'), and the results of the two remote zones are stored in their respective registers.

### 3.3.1 Conversion Rates

The EMC1053 may be configured for different conversion rates based on the system requirements. The available rates are 1 full set of conversions per second to 16 full sets of conversions per second. The available conversion rates are shown in [Table 4.6](#).

### 3.3.2 Dynamic Averaging

The EMC1053 temperature channels support a new feature that measures the external diode channels for an extended period of time based on the selected conversion rate. When Dynamic Averaging is enabled, the device will automatically adjust the sampling and measurement time for both external diode channels. This allows the device to average 2x or 4x longer than the normal 11 bit operation while still maintaining the selected conversion rate. The benefits of Dynamic Averaging are improved noise rejection due to the longer sampling and measurement time as well as reduced jitter on the measurement value for the external temperatures.

The Dynamic Averaging applies when a One-Shot command is issued. The device will perform the desired number of averages during the one-shot operation according to the selected conversion rate.

## 3.4 Temperature Monitors

In general, thermal diode temperature measurements are based on the change in forward bias voltage of a diode when operated at two different currents. This  $\Delta V_{BE}$  is then proportional to absolute temperature as shown in the following equation:

$$\Delta V_{BE} = V_{BE\_HIGH} - V_{BE\_LOW} = \frac{\eta k T}{q} \ln \left( \frac{I_{F2}}{I_{F1}} \right)$$

where:

$k$  = Boltzmann's constant

$T$  = absolute temperature in Kelvin

$q$  = electron charge

$\eta$  = diode ideality factor

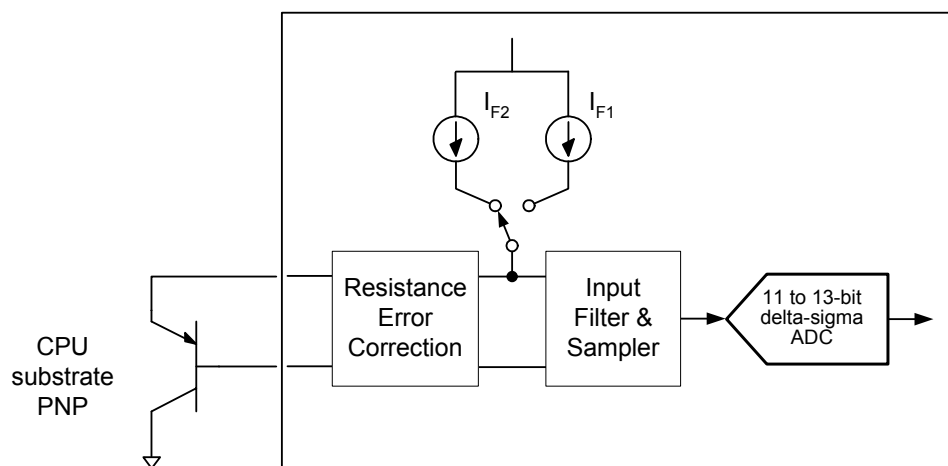
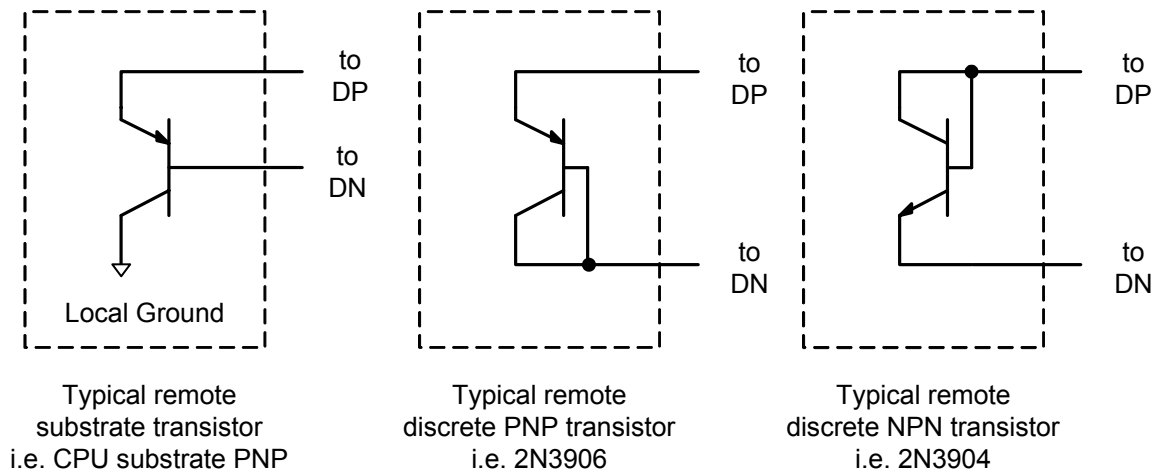

Figure 3.2 Block Diagram of Temperature Monitoring Circuit

Figure 3.2 shows a detailed block diagram of the temperature measurement circuit. The EMC1053 incorporates switched capacitor technology that integrates the temperature diode  $\Delta V_{BE}$ . The negative terminal for the remote temperature diode, DN, is internally biased with a forward diode voltage referenced to ground.

The advantages of this architecture over Nyquist rate FLASH or SAR converters are superb linearity and inherent noise rejection. The linearity can be directly attributed to the delta-sigma ADC single bit comparator while the noise rejection is achieved by the 20.48ms integration time for 11-bit resolution. The input bandwidth of the system is  $f_s/2048$ , this translates to 50Hz at a 100kHz clock frequency.

The remote diodes in the EMC1053 are compatible with a broad range of thermal diodes that may be constructed as shown in Figure 3.3.



**Figure 3.3 Remote Diode Configurations**

### 3.5 Temperature Measurement Results and Data

Each temperature result for each zone is available in two byte wide data registers. As shown in Section 4.1, the 11-bit format has the 8 most significant bits stored in the high byte register and the 3 least significant bits stored in the three MSB positions of the low byte register. The delta-sigma ADC may be operated with more than 11 bits of resolution

The temperature results for the two remote zones are also stored in extended format with a range from -64°C to +191°C. The data format is a 2's complement number offset by 64°C as shown in Section 4.2. The data for each of the remote zones in both legacy and extended format is stored in separate data registers so that both data formats are always available. Table 3.1 shows the default and extended range formats.

**Table 3.1 EMC1053 Temperature Data Format**

TEMPERATURE (°C)	RANGE -64°C TO 127°C	RANGE -64°C TO 191°C
	BINARY	OFFSET BINARY
Diode Fault	100 0000 0000	100 0000 0000
<= -64	110 0000 0000	100 0000 0000
-63.875	110 0000 0001	100 0000 0001
-63	110 0000 1000	100 0000 1000
-1	111 1111 1000	101 1111 1000
0	000 0000 0000	110 0000 0000
0.125	000 0000 0001	110 0000 0001
1	000 0000 1000	110 0000 1000
64	010 0000 0000	000 0000 0000
65	010 0000 1000	000 0000 1000
127	011 1111 1000	001 1111 1000
127.875	011 1111 1111	001 1111 1111
128	011 1111 1111	010 0000 0000
191	011 1111 1111	011 1111 1000
>= 191.875	011 1111 1111	011 1111 1111

### 3.6 Resistance Error Correction

The EMC1053 includes resistance error correction implemented in the analog front end of the chip. Resistance error correction is an automatic feature that eliminates the need to characterize and compensate for the series resistance in the external diode lines. The EMC1053 corrects for as much as 100 ohms of series resistance.

When using a temperature sensor that does not include resistance error correction, voltage developed across the parasitic resistance in the remote diode path produces an error in the reported temperature. The error introduced by this resistance is approximately 0.7°C per ohm. Sources of series resistance are PCB trace resistance, on die (i.e. on the processor) metal resistance, bulk resistance in the base and emitter of the temperature transistor.

### 3.7 Programmable Ideality Factor

To provide maximum flexibility to the user, the EMC1053 provides a 6-bit register for each remote diode as described in [Section 4.7](#). The ideality factor for each remote diode may be configured to eliminate errors across all temperatures when the ideality factor of the remote diode is not 1.008.

The EMC1053 defaults to an ideality factor of 1.008, but not all remote diodes, processor or discrete, have this exact factor. When the ideality factor of the remote diode is not 1.008, the higher the temperature measured, the greater the error introduced.

The ideality factor must be characterized based on a transistor model for the remote diode.

## 3.8 Diode Faults

The EMC1053 detects a fault if the DP pin is left floating or is shorted to VDD. In the case of a diode fault, the corresponding status bit will be set and the output data will be set at 400h. The internal diode cannot have a fault condition associated with it.

## Chapter 4 Register Set and Description

The following registers are accessible through the SMBus Interface.

**Table 4.1 EMC1053 Register Set**

REGISTER ADDRESS		R/W	REGISTER NAME	SYMBOL	B7	B6	B5	B4	B3	B2	B1	B0	DEFAULT VALUE
READ	WRITE												
00h	N/A	R	Internal Temperature High Byte - Legacy Format	INTHBL	Sign	64	32	16	8	4	2	1	00h
23h	N/A	R	Internal Temperature Low Byte - Legacy Format	INTLBL	0.5	0.25	0.125						00h
01h	N/A	R	External Diode 1 High Byte - Legacy Format	ET1HBL	Sign	64	32	16	8	4	2	1	00h
10h	N/A	R	External Diode 1 Low Byte - Legacy Format	ET1LBL	0.5	0.25	0.125						00h
F8h	N/A	R	External Diode 2 High Byte - Legacy Format	ET2HBL	Sign	64	32	16	8	4	2	1	00h
F9h	N/A	R	External Diode 2 Low Byte - Legacy Format	ET2LBL	0.5	0.25	0.125						00h
FAh	N/A	R	External Diode 1 High Byte - Extended Format	ET1HBE	128	64	32	16	8	4	2	1	00h
FBh	N/A	R	External Diode 1 Low Byte - Extended Format	ET1LBE	0.5	0.25	0.125						00h
FCh	N/A	R	External Diode 2 High Byte - Extended Format	ET2HBE	128	64	32	16	8	4	2	1	00h

Table 4.1 EMC1053 Register Set (continued)

REGISTER ADDRESS	REGISTER NAME	SYMBOL	B7	B6	B5	B4	B3	B2	B1	B0	DEFAULT VALUE	
												READ
FDh	External Diode 2 Low Byte - Extended Format	ET2LBE	0.5	0.25	0.125						00h	
Status and Control												
02h	Status	STS	Busy			HOTTER		D2	D1		00h	
03h	Configuration	CFG	-	ADC_ST OP	-	-	-	CR<2:0>			45h	
04h	Configuration 2	CFG2	-	-	-	-	MAX_RES	DA_n	COMP	REC	09h	
One Shot												
N/A	One Shot Conversion	Shot	The data written to this register is irrelevant and will not be stored									00h
Ideality												
27h	External Diode 1 Ideality Correction Factor	IDCF1	-	-	B5	B4	B3	B2	B1	B0	12h (1.008)	
28h	External Diode 2 Ideality Correction Factor	IDCF2	-	-	B5	B4	B3	B2	B1	B0	12h (1.008)	
EDh	Product ID	PID										3C
FEh	Manufacturer ID	SMSC	0	1	0	1	1	1	0	1	5Dh	
FFh	Revision Register	REV	-	-	-	-	0	0	0	0	00h	

During Power on Reset (POR), the default values are stored in the registers. A POR is initiated when power is first applied to the part and the voltage on the VDD supply surpasses the POR level as specified in the electrical characteristics. Any reads to undefined registers will return 00h. Writes to undefined registers will not have an effect.



**Datasheet**

The EMC1053 uses an interlock mechanism that will only update both High and Low byte of a particular monitor when the High Byte is read with a READ command. This prevents changes in register content when fresh readings come in from the ADC during successive reads from a host.

## 4.1 Legacy Temperature Data Registers (00h, 03h, 10h, 23h, F8h)

**Table 4.2 Legacy Temperature data Registers**

REGISTER	B7	B6	B5	B4	B3	B2	B1	B0	DEFAULT
Internal Temp High Byte - Legacy Format	Sign	64	32	16	8	4	2	1	00h
Internal Temp Low Byte - Legacy Format	0.5	0.25	0.125	-	-	-	-	-	00h
External Diode 1 High Byte - Legacy Format	Sign	64	32	16	8	4	2	1	00h
External Diode 1 Low Byte - Legacy Format	0.5	0.25	0.125	-	-	-	-	-	00h
External Diode 2 High Byte - Legacy Format	Sign	64	32	16	8	4	2	1	00h
External Diode 2 Low Byte - Legacy Format	0.5	0.25	0.125	-	-	-	-	-	00h

As shown in [Table 4.2](#), each temperature monitor has two byte wide data registers. The 11 bit data temperature is stored aligned to the left resulting in the High Byte to contain temperature in 1°C steps and the Low Byte to contain fractions of a degree.

Please note that the internal temperature monitor is limited to the operating temperature limits of the part resulting in a maximum range of 0°C to 85°C.

## 4.2 Extended Format Temperature Registers (FAh-FDh)

**Table 4.3 Extended Temperature Data Registers**

REGISTER	B7	B6	B5	B4	B3	B2	B1	B0	DEFAULT
External Diode 1 High Byte - Extended Format	128	64	32	16	8	4	2	1	00h
External Diode 1 Low Byte - Extended Format	0.5	0.25	0.125	-	-	-	-	-	00h
External Diode 2 High Byte - Extended Format	128	64	32	16	8	4	2	1	00h
External Diode 2 Low Byte - Extended Format	0.5	0.25	0.125	-	-	-	-	-	00h



**Datasheet**

The extended format temperature registers store only the external diode temperatures in the extended data format. This is because, due to the operating range limitations of the EMC1053, the internal temperature could not benefit from the extended temperature range. Like the Legacy data formatting, the data is stored in two registers per temperature channel.

### 4.3 Status Register - 02h

**Table 4.4 Status Register**

REGISTER	B7	B6	B5	B4	B3	B2	B1	B0	DEFAULT
Status	Busy	-	-	-		-	D2	D1	00h

The Status register is a read only register and returns the operational status of the part. External diode faults are indicated by bits 1 and 0. If either bit is set to '1', then a diode fault has occurred. When a diode fault occurs, the Status flag is set, but otherwise the data remains unchanged.

Bit 7 - Busy - indicates that the ADC is currently converting a temperature.

Bit 4 - HOTTER - during Hotter of Two mode, this bit indicates which of the external diode channels is hotter. If this bit is '0', then External Diode 1 is hotter. If this bit is '1', then External diode 2 is hotter. During normal operation, this bit will always read a '0'.

Bit 1 - D2 - indicates that a diode fault has occurred on External diode 2.

Bit 0 - D1 - indicates that a diode fault has occurred on External diode 1.

### 4.4 Configuration Register (03h Read, 09h Write)

**Table 4.5 Configuration Register**

REGISTER	B7	B6	B5	B4	B3	B2	B1	B0	DEFAULT
Config	-	ADC_STOP	-	-	-	CR2	CR1	CR0	45h

The configuration register controls the basic functionality of the EMC1053. The bits are described below:

Bit 6 - ADC\_STOP - controls the ADC conversions and power modes of the part

- '0' - The ADC is operational and running at the user specified conversion rate.
- '1' - (default)The ADC is disabled and the part is in its shutdown/standby mode.

Bit 2-0 - CR<2:0> - determines the conversion rate for the temperature monitoring.

**Table 4.6 Conversion Rate**

CR<2:0>			CONVERSIONS / SECOND (CONVERSION TIME)	TYPICAL QUIESCENT CURRENT (μA)
2	1	0		
0	0	0	Reserved	
0	0	1	Reserved	
0	1	0	Reserved	
0	1	1	1 Conversion / sec	139
1	0	0	2 Conversions / sec	200
1	0	1	4 Conversions / sec (default)	340
1	1	0	8 Conversions / sec	652
1	1	1	16 Conversions / sec	756

## 4.5 Configuration 2 register - 04h

**Table 4.7 Configuration Register 2**

REGISTER	B7	B6	B5	B4	B3	B2	B1	B0	DEFAULT
CFG2	-	-	-	-	MAX_RES	DA_n	COMP	REC	09h

The Configuration 2 register controls the basic functionality of the EMC1053 that is NOT compatible with the EMC1023.

Bit 3 - MAX\_RES - controls the number of measurements taken during dynamic averaging. Although the dynamic averaging may be used to increase the ADC resolution, only 11 bits of data are available in the temperature registers.

- '0' - the dynamic averaging will set the internal ADC resolution at 11 bits when the conversion rate is set at 16 conversions per second and 12 bits at conversion rates lower than 16 per second.
- '1' - the dynamic averaging will set the internal ADC resolution at 11 bits when the conversion rate is set at 16 conversions per second, 12 bits at 8 conversions / second and 13 bits at conversion rates lower than 8 per second.

Bit 2 - DA\_n - controls the dynamic digital averaging circuitry. See [Section 3.3.2](#).

- '0' (default) - dynamic averaging is enabled. Depending on the selected conversion rate, the internal ADC resolution is increased for the external diodes.
- '1' - dynamic averaging is disabled. The internal ADC resolution will remain fixed over all conversion rates and will allow increased power savings at the slower conversion rates.

**Table 4.8 Overview of Averaging Options**

DA_N	MAX_RES	CONVERSION RATE	INTERNAL ADC RESOLUTION
0	0	16 / sec	11 bit
0	0	8 / sec - 1 / sec	12 bit
0	1	16 / sec	11bit
0	1	8 / sec	12 bit
0	1	4 / sec - 1/sec	13 bit
1	0	16 / sec - 1 / sec	11 bit
1	1	16 / sec - 1 / sec	11 bit

Bit 1 - COMP - configures the device to perform a comparison for the Hotter of Two mode (see [Section 3.3, "Operation During Run Mode," on page 8](#))

- '0' (default) - the device is in normal mode
- '1' - the device is in Hotter of Two mode. In this mode, the two external channels are measured and compared against each other. The hotter of the two channels has its data loaded into the External Diode 2 data bytes. The Internal channel and External Channel 1 data registers remain unaffected.

Bit 0 - REC - controls the Resistance Error Correction circuitry

- '0' - The Resistance Error Correction circuitry is disabled.
- '1' (default)- The Resistance Error Correction circuitry is active and will automatically correct for up to 100 ohms of series resistance in the diode lines

## 4.6 One Shot Register - 0Fh

**Table 4.9 One Shot Registers**

REGISTER	B7	B6	B5	B4	B3	B2	B1	B0	DEFAULT
One Shot Conversion	Writing to this register address initiates the one-shot. The data is not important and is not stored								00h

The One Shot register is an address place holder for the one-shot command. Writing to the address initiates the command. The data written is not important and is not stored. Reading from the one-shot registers will always return 00h.

## 4.7 Ideality Configuration Factor Registers (27h - 28h)

**Table 4.10 Ideality Configuration Register**

REGISTER	B7	B6	B5	B4	B3	B2	B1	B0	DEFAULT
Diode 1 Ideality Correction Factor	-	-	B5	B4	B3	B2	B1	B0	12h (1.008)
Diode 2 Ideality Correction Factor	-	-	B5	B4	B3	B2	B1	B0	12h (1.008)

This register stores the ideality correction factor that is (by default) automatically applied to each external diode.

The table below shows the ideality factor settings for the Ideality Configuration registers. Red shading indicates power-up default.

**Table 4.11 Ideality Configuration**

SETTING	FACTOR	SETTING	FACTOR	SETTING	FACTOR	SETTING	FACTOR
000000	0.9850	010000	1.0054	100000	1.0267	010000	1.0489
000001	0.9862	010001	1.0067	100001	1.0280	010001	1.0503
000010	0.9875	010010	1.0080	100010	1.0294	010010	1.0517
000011	0.9888	010011	1.0093	100011	1.0308	010011	1.0531
000100	0.9900	010100	1.0106	100100	1.0321	010100	1.0546
000101	0.9913	010101	1.0119	100101	1.0335	010101	1.0560
000110	0.9925	010110	1.0133	100110	1.0349	010110	1.0574
000111	0.9938	010111	1.0146	100111	1.0363	110111	1.0589
001000	0.9951	011000	1.0159	101000	1.0377	111000	1.0603
001001	0.9964	011001	1.0173	101001	1.0391	111001	1.0618
001010	0.9976	011010	1.0186	101010	1.0404	111010	1.0632
001011	0.9989	011011	1.0199	101011	1.0418	111011	1.0647
001100	1.0002	011100	1.0213	101100	1.0432	111100	1.0661
001101	1.0015	011101	1.0226	101101	1.0446	111101	1.0676
001110	1.0028	011110	1.0240	101110	1.0460	111110	1.0690
001111	1.0041	011111	1.0253	101111	1.0475	111111	1.0705

## 4.8 Product ID Register (EDh)

The Product ID Register holds the unique product ID for identifying SMSC EMC products. See [Table 4.1](#) for a list of the product ID number for each version of the EMC1053.

Datasheet

## **4.9 Manufacturer ID Register (FEh)**

The Manufacturer ID register contains an 8 bit word that identifies the manufacturer of the EMC1053 (SMSC = 5Dh)

## **4.10 Revision Register (FFh)**

The Revision register contains a 4 bit word that identifies the die revision.

## Chapter 5 Typical Operating Curves

The following curves show the typical operating characteristics of the EMC1053

1. Temperature measurement accuracy vs. ambient air temperature
2. Temperature measurement accuracy vs. external diode temperature
3. Temperature measurement accuracy vs. power supply variation
4. Supply current vs. Conversion Rate.
5. Temperature accuracy vs. input capacitance
6. Diode leakage current vs. ambient die temperature
7. Temperature accuracy vs. differential noise.

## Chapter 6 Package Outline

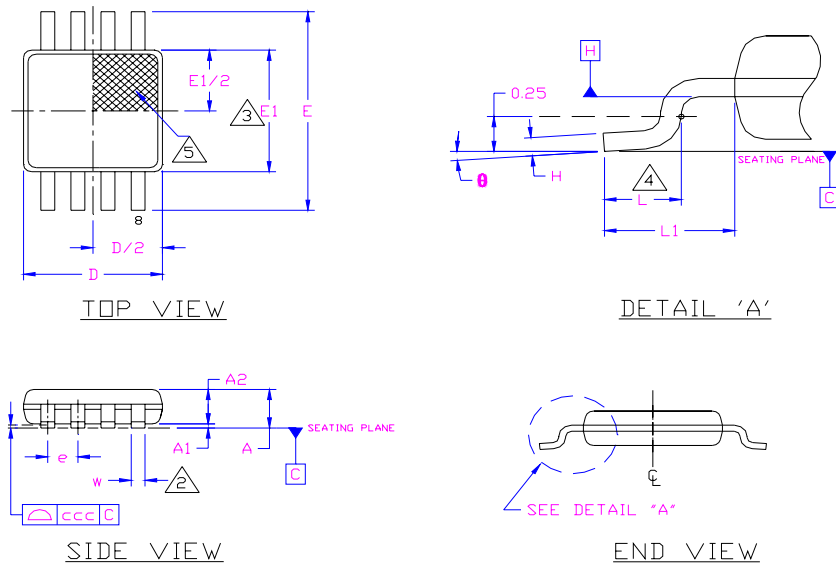

Figure 6.1 8-Pin MSOP Package Outline - 3x3mm Body 0.65mm Pitch

Table 6.1 8-Pin MSOP Package Parameters

	MIN	NOMINAL	MAX	REMARKS
A	0.80	~	1.10	Overall Package Height
A1	0.05	~	0.15	Standoff
A2	0.75	0.85	0.95	Body Thickness
D	2.80	3.00	3.20	X Body Size
E	4.65	4.90	5.15	Y Span
E1	2.80	~	3.20	Y body Size
H	0.08	~	0.23	Lead Foot Thickness
L	0.40	~	0.80	Lead Foot Length
L1	0.95 REF			Lead Length
e	0.65 BSC			Lead Pitch
$\theta$	0°	~	8°	Lead Foot Angle
W	0.22	~	0.38	Lead Width
ccc	~	~	0.10	Coplanarity

**Notes:**

- Controlling Unit: millimeters.
- Tolerance on the true position of the leads is  $\pm 0.065$  mm maximum.
- Package body dimensions D and E1 do not include mold protrusion or flash. Dimensions D and E1 to be determined at datum plane H. Maximum mold protrusion or flash is 0.15mm (0.006 inches) per end, and 0.15mm (0.006 inches) per side.
- Dimension for foot length L measured at the gauge plane 0.25 mm above the seating plane.
- Details of pin 1 identifier are optional but must be located within the zone indicated.

## 6.1 Package Markings

All devices will be marked on the first line of the top side with “1053”. On the second line, they will be marked with version (V), revision (R) and country of origin (CC) resulting in a four letter code of (VRCC).