



IPAD™

EMIF02-MIC02F2

2 LINES EMI FILTER INCLUDING ESD PROTECTION

MAIN PRODUCT CHARACTERISTICS:

Where EMI filtering in ESD sensitive equipment is required:

- Mobile phones and communication systems
- Computers, printers and MCU Boards

DESCRIPTION

The EMIF02-MIC02 is a highly integrated devices designed to suppress EMI/RFI noise in all systems subjected to electromagnetic interferences. The EMIF02 flip chip packaging means the package size is equal to the die size.

This filter includes an ESD protection circuitry which prevents the device from destruction when subjected to ESD surges up 15kV.

BENEFITS

- EMI symmetrical (I/O) low-pass filter
- High efficiency in EMI filtering
- Lead free package
- Very low PCB space consuming: 1.07mm x 1.57mm
- Very thin package: 0.65 mm
- High efficiency in ESD suppression
- High reliability offered by monolithic integration
- High reducing of parasitic elements through integration & wafer level packaging.

COMPLIES WITH THE FOLLOWING STANDARDS:

IEC61000-4-2

Level 4 on input pins 15kV (air discharge)
8kV (contact discharge)

Level 1 on output pins 2kV (air discharge)
2kV (contact discharge)

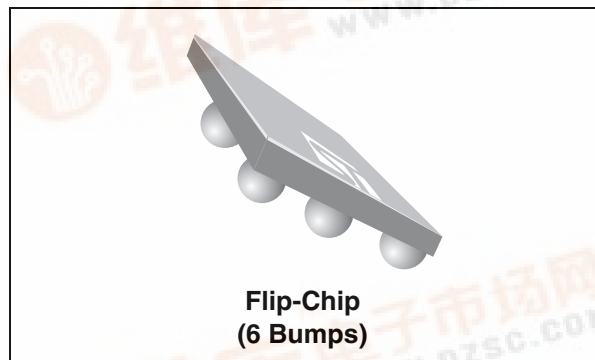

Table 1: Order Code

Part Number	Marking
EMIF02-MIC02F2	FJ

Figure 1: Pin Configuration (Ball side)

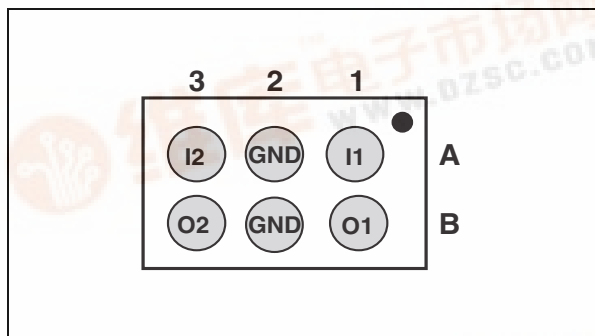
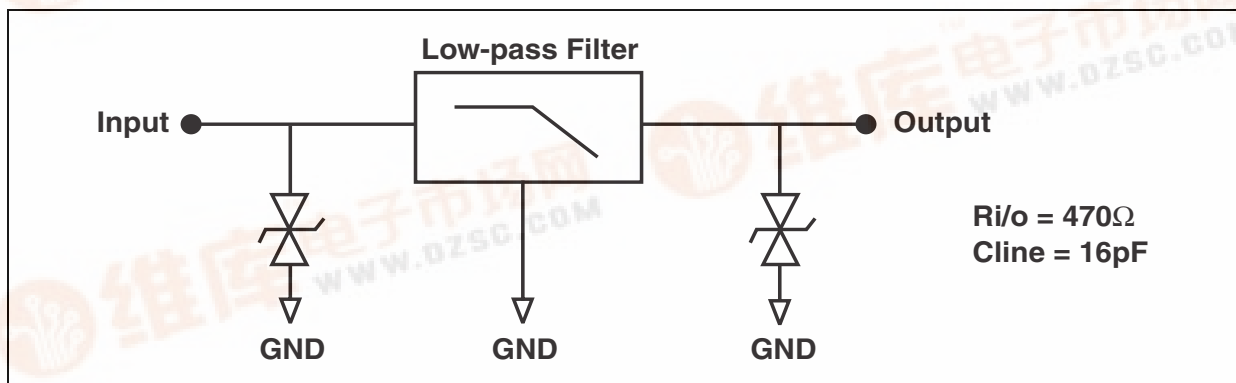

Figure 2: Basic Cell Configuration



TM: IPAD is a trademark of STMicroelectronics.



EMIF02-MIC02F2

Table 2: Absolute Ratings (limiting values)

Symbol	Parameter and test conditions	Value	Unit
T_j	Maximum junction temperature	125	°C
T_{op}	Operating temperature range	- 40 to + 85	°C
T_{stg}	Storage temperature range	- 55 to + 150	°C

Table 3: Electrical Characteristics ($T_{amb} = 25^\circ\text{C}$)

Symbol	Parameter
V_{BR}	Breakdown voltage
I_{RM}	Leakage current @ V_{RM}
V_{RM}	Stand-off voltage
V_{CL}	Clamping voltage
R_d	Dynamic impedance
I_{PP}	Peak pulse current
$R_{I/O}$	Series resistance between Input & Output
C_{line}	Input capacitance per line

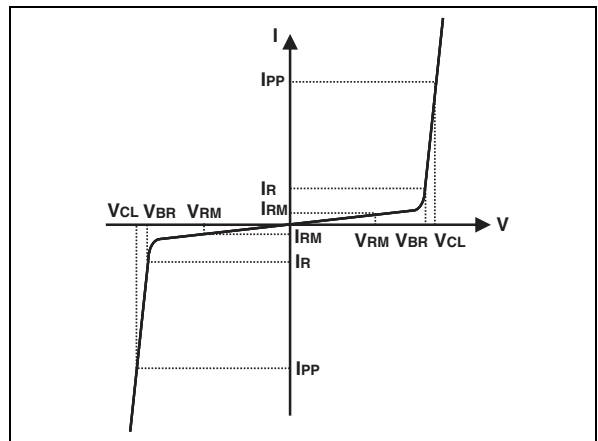

Symbol	Test conditions	Min.	Typ.	Max.	Unit
V_{BR}	$I_R = 1 \text{ mA}$	14	16		V
I_{RM}	$V_{RM} = 12\text{V}$ per line			500	nA
$R_{I/O}$		423	470	517	Ω
C_{line}	@ 0V		16		pF

Figure 3: S21 (dB) attenuation measurement and Aplac simulation

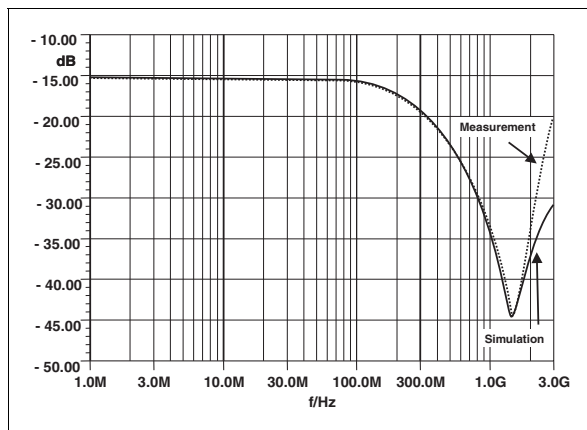

Figure 4: Analog crosstalk measurements

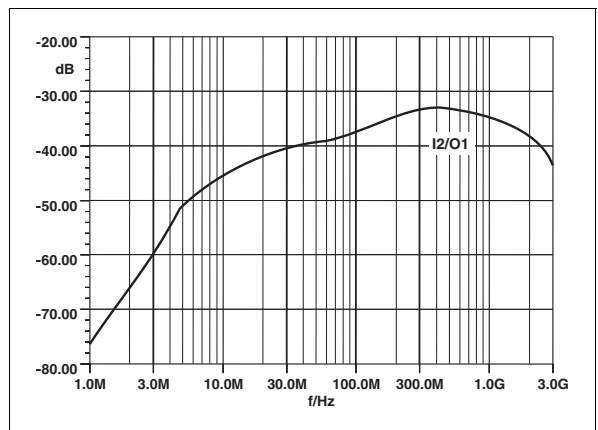

Figure 5: Digital crosstalk measurement

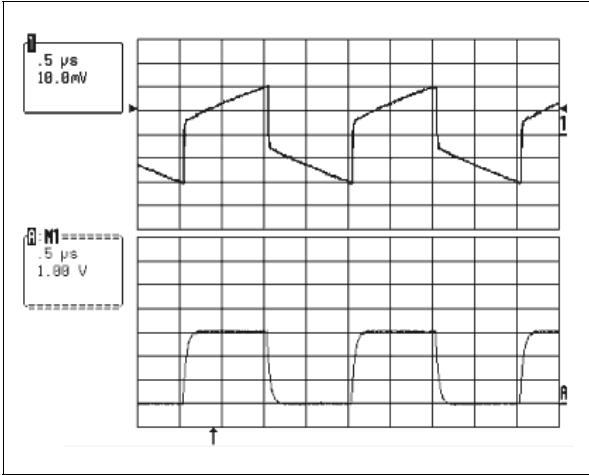

Figure 6: ESD response to IEC61000-4-2 (+15kV air discharge) on one input V(in) and on one output (Vout)

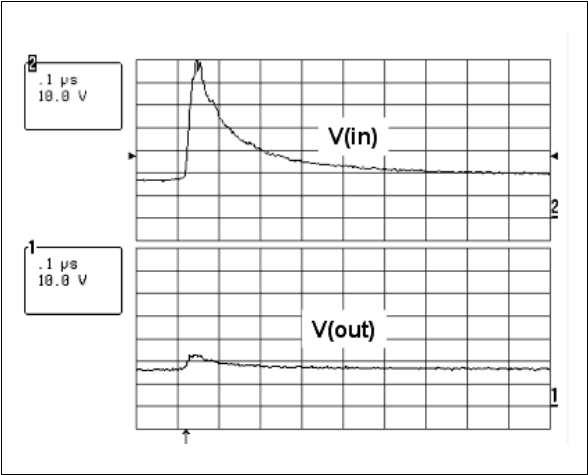

Figure 7: ESD response to IEC61000-4-2 (+15kV air discharge) on one input V(in) and on one output (Vout)

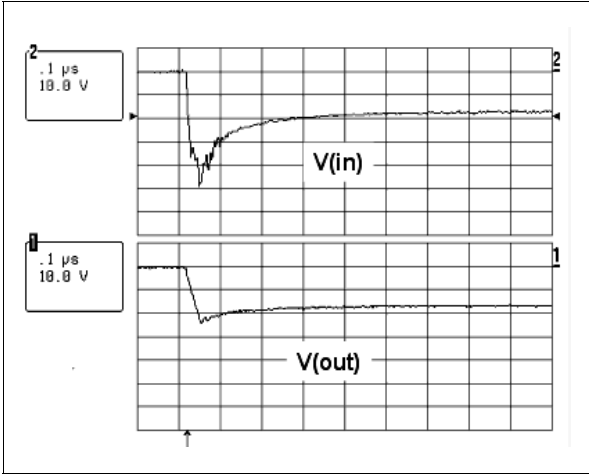
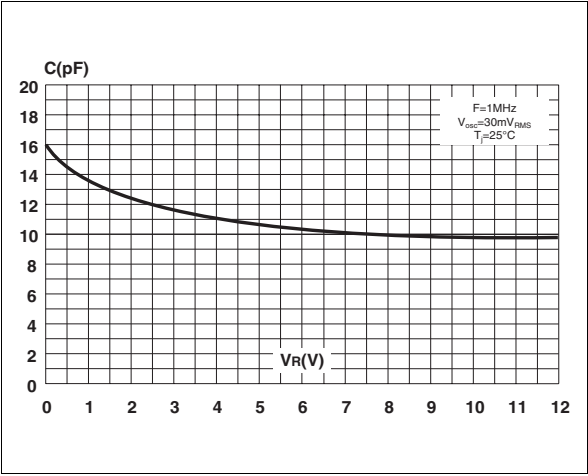

Figure 8: Line capacitance versus applied voltage



EMIF02-MIC02F2

Figure 9: Aplac model

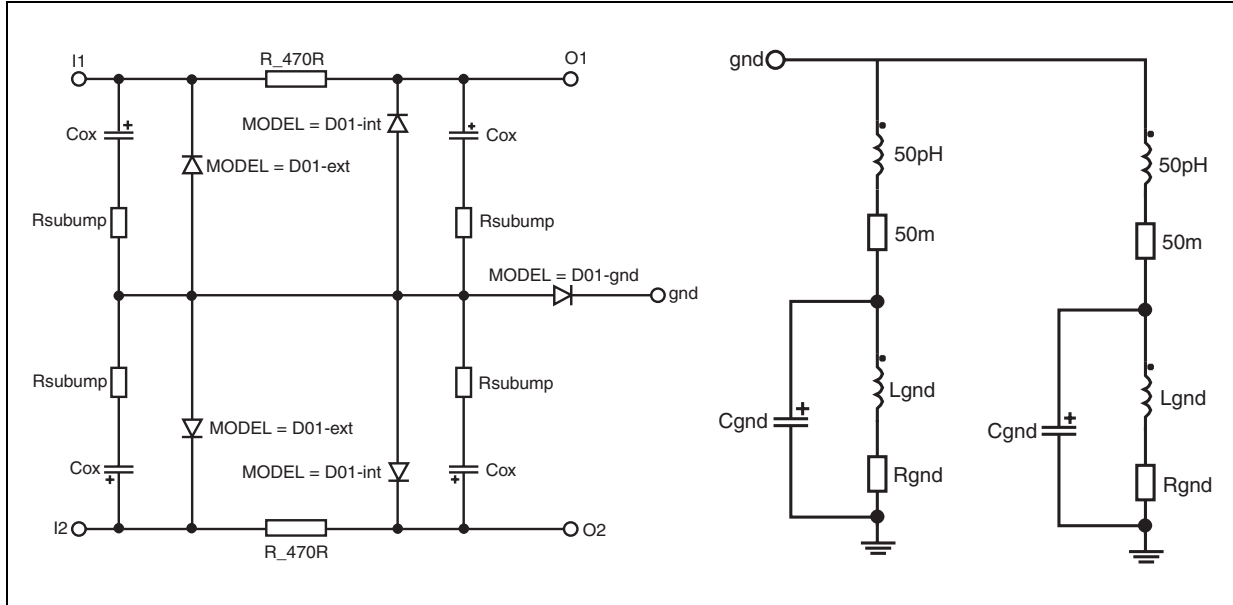

Figure 10: Aplac parameters

Model D01-ext	Model D01-int	Model D01-gnd	
BV = 7	BV = 7	BV = 7	Ls 400pH
CJO = Cz_ext	CJO = Cz_int	CJO = Cz_gnd	Rs 100m
IBV = 1u	IBV = 1u	IBV = 1u	R_470R 482.6
IKF = 1000	IKF = 1000	IKF = 1000	Cz_ext 8.73pF
IS = 10f	IS = 10f	IS = 10f	Rs_ext 850m
ISR = 100p	ISR = 100p	ISR = 100p	Cz_int 2.9pF
N = 1	N = 1	N = 1	Rs_int 850m
M = 0.3333	M = 0.3333	M = 0.3333	Cz_gnd 215.61pF
RS = Rs_ext	RS = Rs_int	RS = Rs_gnd	Rs_gnd 470m
VJ = 0.6	VJ = 0.6	VJ = 0.6	Rgnd 10m
TT = 50n	TT = 50n	TT = 50n	Lgnd 48pH
			Cgnd 0.15pF
			Cox 3.05pF
			Rsubump 200m

Figure 11: Ordering Information Scheme

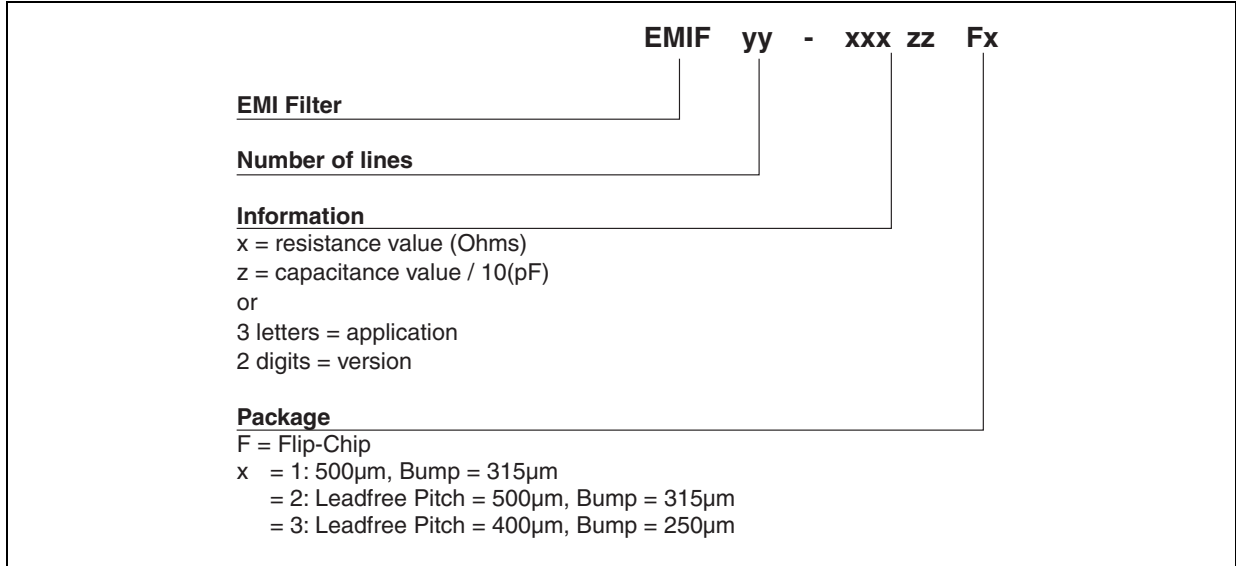

Figure 12: FLIP-CHIP Package Mechanical Data

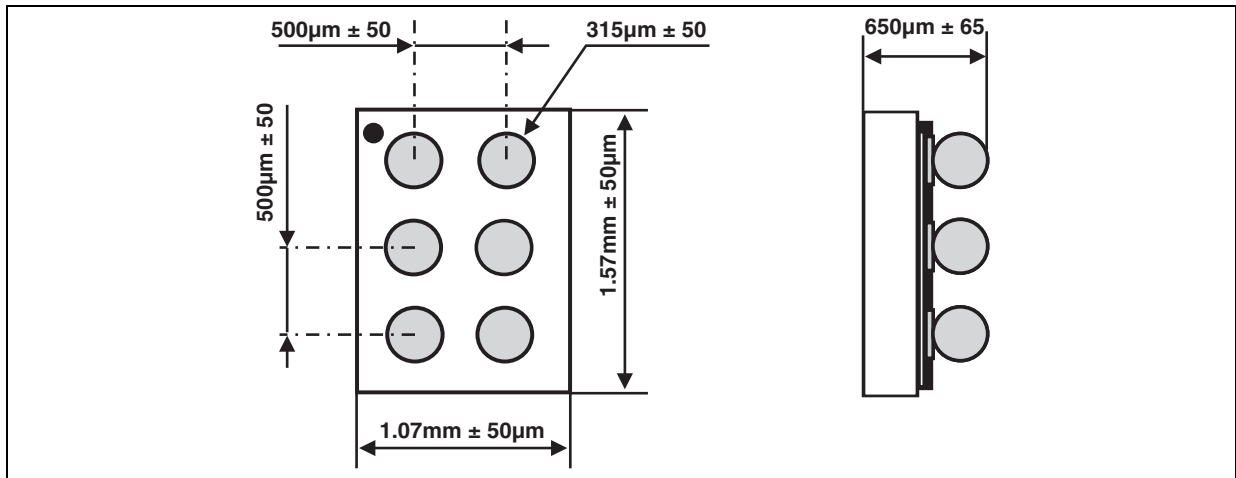

Figure 13: Foot print recommendations

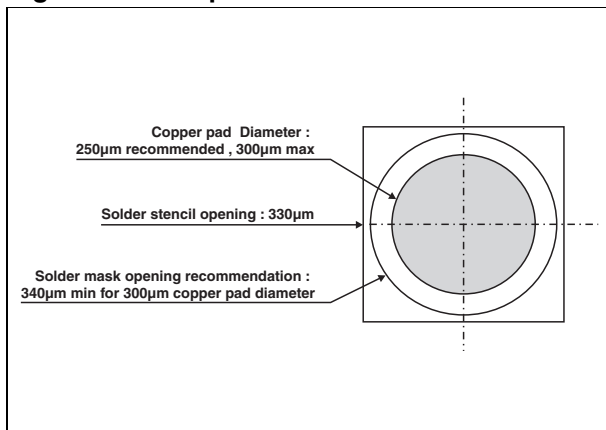
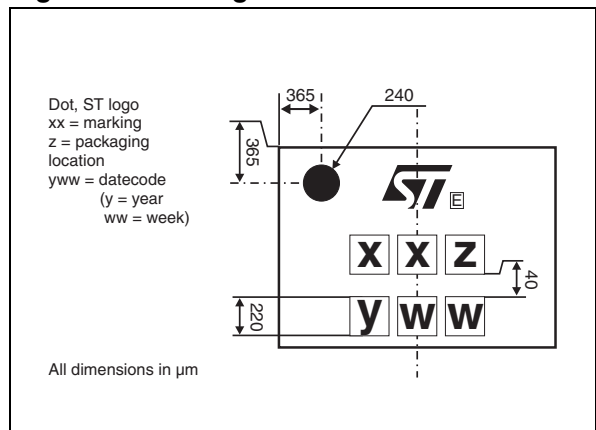

Figure 14: Marking



EMIF02-MIC02F2

Figure 15: FLIP-CHIP Tape and Reel Specification

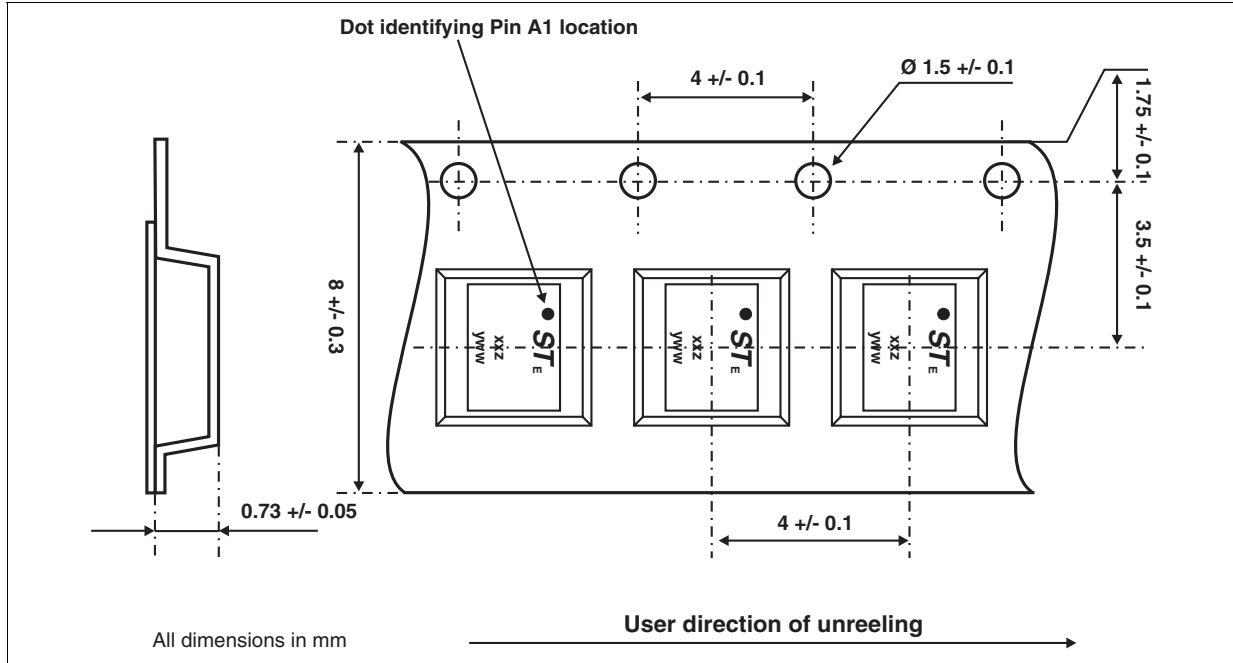

Table 4: Ordering Information

Ordering code	Marking	Package	Weight	Base qty	Delivery mode
EMIF02-MIC02F2	FJ	Flip-Chip	2.3 mg	5000	Tape & reel 7"

Note: More informations are available in the application notes:
 AN1235: "Flip-Chip: Package description and recommendations for use"
 AN1751: "EMI Filters: Recommendations and measurements"

Table 5: Revision History

Date	Revision	Description of Changes
12-Oct-2004	1	First issue

Information furnished is believed to be accurate and reliable. However, STMicroelectronics assumes no responsibility for the consequences of use of such information nor for any infringement of patents or other rights of third parties which may result from its use. No license is granted by implication or otherwise under any patent or patent rights of STMicroelectronics. Specifications mentioned in this publication are subject to change without notice. This publication supersedes and replaces all information previously supplied. STMicroelectronics products are not authorized for use as critical components in life support devices or systems without express written approval of STMicroelectronics.

The ST logo is a registered trademark of STMicroelectronics.
All other names are the property of their respective owners

© 2004 STMicroelectronics - All rights reserved

STMicroelectronics group of companies

Australia - Belgium - Brazil - Canada - China - Czech Republic - Finland - France - Germany - Hong Kong - India - Israel - Italy - Japan -
Malaysia - Malta - Morocco - Singapore - Spain - Sweden - Switzerland - United Kingdom - United States of America
www.st.com