

## FEATURES

- **ARM720T processor**
  - ARM7TDMI CPU
  - 8 K-bytes of four-way set-associative cache
  - MMU with 64-entry TLB (transition look-aside buffer)
  - Write Buffer
  - Windows® CE enabled
  - Thumb code support enabled
- **Dynamically programmable clock speeds of 18, 36, 49, and 74 MHz at 2.5 V**
- **Performance matching 100-MHz Intel® Pentium-based PC**
- **Ultra low power**
  - Designed for applications that require long battery life while using standard AA/AAA batteries or rechargeable cells
  - Typical Power Numbers
    - 90 mW at 74 MHz in the Operating State
    - 30 mW at 18 MHz in the Operating State
    - 10 mW in the Idle State (clock to the CPU stopped, everything else running)
    - <1 mW in the Standby State (realtime clock 'on', everything else stopped)

(cont.)

## High-Performance, Low-Power System-on-Chip with LCD Controller and Digital Audio Interface (DAI)

## OVERVIEW

The EP7212 is designed for ultra-low-power applications such as organizers / PDAs, two-way pagers, smart cellular phones or any vertical PDA device that features the added capability of digital audio decompression. The core-logic functionality of the device is built around an ARM720T processor with 8 K-bytes of four-way set-associative unified cache and a write buffer. Incorporated into the ARM720T is an enhanced memory management unit (MMU) which allows for support of sophisticated operating systems like Microsoft Windows CE.

(cont.)

## Functional Block Diagram

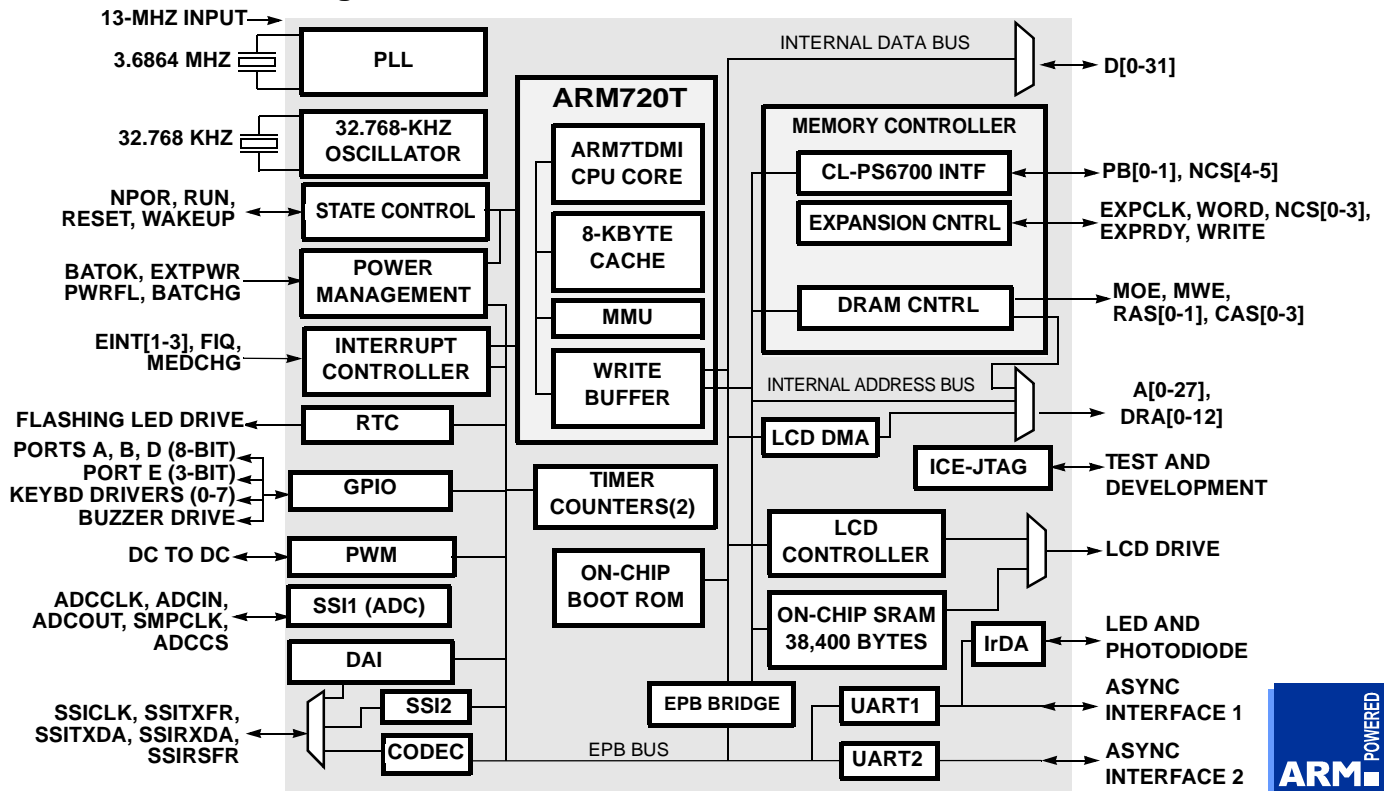

## FEATURES (cont.)

### ■ Advanced audio decoder / decompression capability

- Allows for support of multiple audio decompression algorithms
- Supports MPEG 1, 2, & 2.5 layer 3 audio decoding, including ISO compliant MPEG 1 & 2 layer 3 support for all standard sample rates and bit rates
- Supports bit streams with adaptive bit rates
- DAI (Digital Audio Interface) providing glueless interface to low-power DACs, ADCs, and Codecs

### ■ LCD controller

- Interfaces directly to a single-scan panel monochrome LCD
- Panel width size is programmable from 32 to 1024 pixels in 16-pixel increments
- Video frame buffer size programmable up to 128 kbytes
- Bits per pixel of 1, 2, or 4 bits

### ■ DRAM controller

- Supports both 16- and 32-bit-wide DRAMs
- EDO support (Fast Page Mode support for 13 MHz and 18 MHz operation only)

### ■ Memory controller

- Decodes up to 6 separate memory segments of up to 256 Mbytes each
- Each segment can be configured as 8, 16, or 32 bits wide and supports page-mode access
- Programmable access time for conventional ROM / SRAM / FLASH memory
- Supports Removable FLASH card interface
- Enables connection to removable FLASH card for addition of expansion FLASH memory modules

### ■ 38,400 bytes (0x9600) of on-chip SRAM for fast program execution and / or as a frame buffer

### ■ Synchronous serial interface

- ADC (SSI) Interface: Master mode only; SPI<sup>®</sup> and Microwire1<sup>®</sup>-compatible (128 kbps operation)

### ■ On-chip ROM; for manufacturing support

### ■ 27-bits of general-purpose I/O

- Three 8-bit and one 3-bit GPIO port
- Supports scanning keyboard matrix

### ■ Two UARTs (16550 type)

- Supports bit rates up to 115.2 kbps
- Contains two 16-byte FIFOs for TX and RX
- UART1 supports modem control signals

### ■ SIR (up to 115.2 kbps) infrared encoder / decoder

- IrDA (Infrared Data Association) SIR protocol encoder / decoder

### ■ DC-to-DC converter interface (PWM)

- Provides two 96-kHz clock outputs with programmable duty ratio (from 1-in-16 to 15-in-16) that can be used to drive a DC to DC converter

### ■ Two timer counters

### ■ 208-pin LQFP or new 256-ball PBGA packages

### ■ Evaluation kit available with BOM, schematics, sample code, and design database

### ■ Support for up to two ultra-low-power CL-PS6700 PC Card controllers

### ■ Dedicated LED flasher pin from RTC

### ■ Full JTAG boundary scan and Embedded ICE<sup>®</sup> support

### ■ Commercial operating temperature range

## OVERVIEW (cont.)

The EP7212 also includes a 32-bit Y2K-compliant realtime clock and comparator.

### Power Management

The EP7212 is designed for ultra-low-power operation. Its core operates at only 2.5 V, while its I/O has an operation range of 2.5 V–3.3 V. The device has three basic power states:

**Operating** — This state is the full performance state. All the clocks and peripheral logic are enabled.

**Idle** — This state is the same as the Operating State, except the CPU clock is halted while waiting for an event such as a key press.

**Standby** — This state is equivalent to the computer being switched off (no display), and the main oscillator shut down. An event such as a key press can wake-up the processor.

### Memory Interfaces

There are two main external memory interfaces.

The first one is the ROM / SRAM / FLASH-style interface that has programmable wait-state timings and includes burst-mode capability, with eight chip selects decoding six 256-Mbyte sections of addressable space. For maximum flexibility, each bank can be specified to be 8, 16, or 32 bits wide. This allows the use of 8-bit-wide boot ROM options to minimize over-

**OVERVIEW** (cont.)

all system cost. The on-chip boot ROM can be used in product manufacturing to serially download system code into system FLASH memory. To further minimize system memory requirements and cost, the ARM Thumb<sup>®</sup> instruction set is supported, providing for the use of high-speed 32-bit operations in 16-bit op-codes and yielding industry-leading code density.

The second is the programmable 16- or 32-bit-wide DRAM interface that allows direct connection of up to two banks of DRAM, each bank containing up to 256 Mbytes. To assure the lowest possible power consumption, the EP7212 supports self-refresh DRAMs, which are placed in a low-power state by the device when it enters the low-power Standby State. EDO and Fast Page DRAM are supported.

A DMA address generator is also provided that fetches video display data for the LCD controller from main DRAM memory. The display frame buffer start address is programmable. In addition, the built-in LCD controller can utilize external or internal SRAM for memory, thus eliminating the need for DRAMs.

**Digital Audio Capability**

The EP7212 uses its powerful 32-bit RISC processing engine to implement audio decompression algorithms in software. The nature of the on-board RISC processor and the availability of efficient C-compilers and other software development tools, ensures that a wide range of audio decompression algorithms can easily be ported to and run on the EP7212.

**Serial Interfaces**

The EP7212 includes two 16550-type UARTs for RS-232 serial communications, both of which have two 16-byte FIFOs for receiving and transmitting data. The UARTs support bit rates up to 115.2 kbps. An IrDA SIR protocol encoder / decoder can be optionally switched into the RX / TX signals to / from one of the UARTs to enable these signals to drive an infrared communication interface directly.

**Digital Audio Interface (DAI)**

The EP7212 integrates an interface to enable a direct connection to many low cost, low power, high quality audio converters. In particular, the DAI can directly interface with the Crystal<sup>®</sup> CS43L41 / 42 / 43 low-power audio DACs and the Crystal<sup>®</sup> CS53L32 low-power ADC. Some of these devices feature digital bass and treble boost, digital volume control and compressor-limiter functions.

**Packaging**

The EP7212 is available in a 208-pin LQFP package and a 256-ball PBGA package.

**System Design**

As shown in system block diagram, simply adding desired memory and peripherals to the highly integrated EP7212 completes a low-power system solution. All necessary interface logic is integrated on-chip.

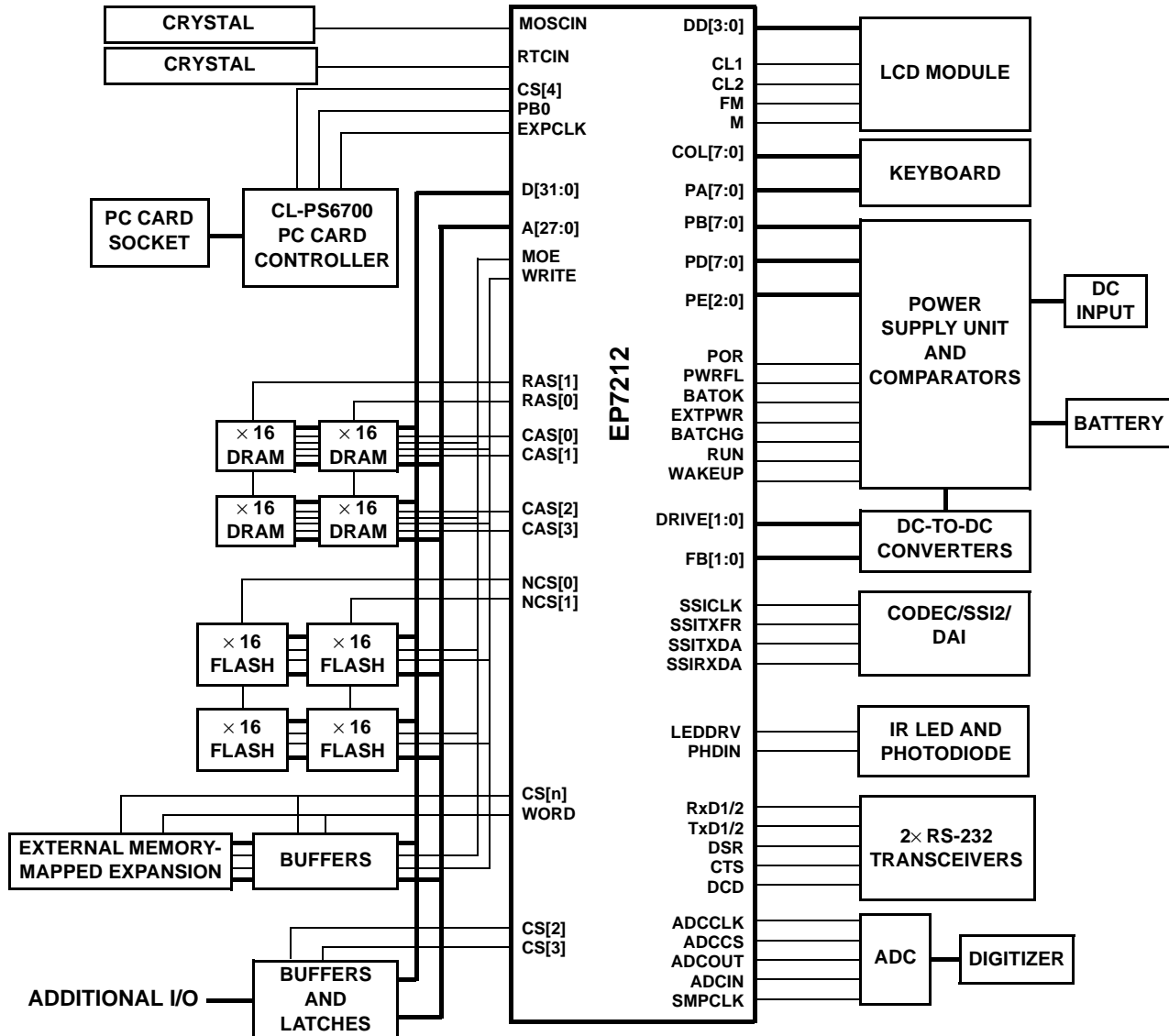

**A EP7212-Based System**

**TABLE OF CONTENTS**

<b>1. CONVENTIONS .....</b>	<b>11</b>
1.1 Acronyms and Abbreviations .....	11
1.2 Units of Measurement .....	12
1.3 General Conventions .....	12
1.4 Pin Description Conventions .....	12
<b>2. PIN INFORMATION .....</b>	<b>13</b>
2.1 208-Pin LQFP Pin Diagram .....	13
2.2 Pin Descriptions .....	14
2.2.1 External Signal Functions .....	14
2.2.2 SSI/Codec/DAI Pin Multiplexing .....	18
2.2.3 Output Bi-Directional Pins .....	18
<b>3. FUNCTIONAL DESCRIPTION .....</b>	<b>19</b>
3.1 CPU Core .....	20
3.2 State Control .....	21
3.2.1 Standby State .....	21
3.2.1.1 UART in Standby State .....	22
3.2.2 Idle State .....	23
3.2.3 Keyboard Interrupt .....	23
3.3 Power-Up Sequence .....	23
3.4 Resets .....	24
3.5 Clocks .....	25
3.5.1 On-Chip PLL .....	25
3.5.1.1 Characteristics of the PLL Interface .....	25
3.5.2 External Clock Input (13 MHz) .....	26
3.5.3 Dynamic Clock Switching When in the PLL Clocking Mode .....	26
3.6 Interrupt Controller .....	27
3.6.1 Interrupt Latencies in Different States .....	27
3.6.1.1 Operating State .....	27
3.6.1.2 Idle State .....	29
3.6.1.3 Standby State .....	29
3.7 EP7212 Boot ROM .....	29
3.8 Memory and I/O Expansion Interface .....	30
3.9 DRAM Controller with EDO Support .....	31
3.10 CL-PS6700 PC Card Controller Interface .....	33
3.11 Endianness .....	36
3.12 Internal UARTs (Two) and SIR Encoder .....	36
3.13 Serial Interfaces .....	38

**Contacting Cirrus Logic Support**

For a complete listing of Direct Sales, Distributor, and Sales Representative contacts, visit the Cirrus Logic web site at:  
<http://www.cirrus.com/corporate/contacts/>

Preliminary product information describes products which are in production, but for which full characterization data is not yet available. Advance product information describes products which are in development and subject to development changes. Cirrus Logic, Inc. has made best efforts to ensure that the information contained in this document is accurate and reliable. However, the information is subject to change without notice and is provided "AS IS" without warranty of any kind (express or implied). No responsibility is assumed by Cirrus Logic, Inc. for the use of this information, nor for infringements of patents or other rights of third parties. This document is the property of Cirrus Logic, Inc. and implies no license under patents, copyrights, trademarks, or trade secrets. No part of this publication may be copied, reproduced, stored in a retrieval system, or transmitted, in any form or by any means (electronic, mechanical, photographic, or otherwise) without the prior written consent of Cirrus Logic, Inc. Items from any Cirrus Logic website or disk may be printed for use by the user. However, no part of the printout or electronic files may be copied, reproduced, stored in a retrieval system, or transmitted, in any form or by any means (electronic, mechanical, photographic, or otherwise) without the prior written consent of Cirrus Logic, Inc. Furthermore, no part of this publication may be used as a basis for manufacture or sale of any items without the prior written consent of Cirrus Logic, Inc. The names of products of Cirrus Logic, Inc. or other vendors and suppliers appearing in this document may be trademarks or service marks of their respective owners which may be registered in some jurisdictions. A list of Cirrus Logic, Inc. trademarks and service marks can be found at <http://www.cirrus.com>

3.13.1	Codec Sound Interface .....	39
3.13.2	Digital Audio Interface .....	40
3.13.2.1	DAI Operation .....	41
3.13.2.2	DAI Frame Format .....	41
3.13.2.3	DAI Signals .....	42
3.13.3	ADC Interface — Master Mode Only SSI1 (Synchronous Serial Interface) .....	42
3.13.4	Master / Slave SSI2 (Synchronous Serial Interface 2) .....	43
3.13.4.1	Read Back of Residual Data .....	44
3.13.4.2	Support for Asymmetric Traffic .....	45
3.13.4.3	Continuous Data Transfer .....	45
3.13.4.4	Discontinuous Clock .....	45
3.13.4.5	Error Conditions .....	46
3.13.4.6	Clock Polarity .....	46
3.14	LCD Controller with Support for On-Chip Frame Buffer .....	46
3.15	Timer Counters .....	47
3.15.1	Free Running Mode .....	48
3.15.2	Prescale Mode .....	48
3.16	Real Time Clock .....	49
3.16.1	Characteristics of the Real Time Clock Interface .....	49
3.17	Dedicated LED Flasher .....	49
3.18	Two PWM Interfaces .....	49
3.19	Boundary Scan .....	50
3.20	In-Circuit Emulation .....	50
3.20.1	Introduction .....	50
3.20.2	Functionality .....	51
3.21	Maximum EP7212-Based System .....	51
<b>4.</b>	<b>MEMORY MAP .....</b>	<b>53</b>
<b>5.</b>	<b>REGISTER DESCRIPTIONS .....</b>	<b>54</b>
5.1	Internal Registers .....	54
5.1.1	PADR Port A Data Register .....	57
5.1.2	PBDR Port B Data Register .....	57
5.1.3	PDDR Port D Data Register .....	57
5.1.4	PADDR Port A Data Direction Register .....	58
5.1.5	PBDDR Port B Data Direction Register .....	58
5.1.6	PDDDR Port D Data Direction Register .....	58
5.1.7	PEDR Port E Data Register .....	58
5.1.8	PEDDR Port E Data Direction Register .....	58
5.2	SYSTEM Control Registers .....	58
5.2.1	SYSCON1 The System Control Register 1 .....	58
5.2.2	SYSCON2 System Control Register 2 .....	61
5.2.3	SYSCON3 System Control Register 3 .....	63
5.2.4	SYSFLG1 — The System Status Flags Register .....	64
5.2.5	SYSFLG2 System Status Register 2 .....	66
5.3	Interrupt Registers .....	67
5.3.1	INTSR1 Interrupt Status Register 1 .....	67
5.3.2	INTMR1 Interrupt Mask Register 1 .....	68
5.3.3	INTSR2 Interrupt Status Register 2 .....	69
5.3.4	INTMR2 Interrupt Mask Register 2 .....	69
5.3.5	INTSR3 Interrupt Status Register 3 .....	70
5.3.6	INTMR3 Interrupt Mask Register 3 .....	70
5.4	Memory Configuration Registers .....	71
5.4.1	MEMCFG1 Memory Configuration Register 1 .....	71
5.4.2	MEMCFG2 Memory Configuration Register 2 .....	71



- 5.5 Timer / Counter Registers ..... 74
  - 5.5.1 TC1D Timer Counter 1 Data Register ..... 74
  - 5.5.2 TC2D Timer Counter 2 Data Register ..... 74
  - 5.5.3 RTCDR Real Time Clock Data Register ..... 74
  - 5.5.4 RTCMR Real Time Clock Match Register ..... 74
- 5.6 LEDFLSH Register ..... 75
- 5.7 PMPCON Pump Control Register ..... 76
- 5.8 CODR — The CODEC Interface Data Register ..... 77
- 5.9 UART Registers ..... 77
  - 5.9.1 UARTDR1–2, UART1–2 Data Registers ..... 77
  - 5.9.2 UBRLCR1–2 UART1–2 Bit Rate and Line Control Registers ..... 78
- 5.10 LCD Registers ..... 79
  - 5.10.1 LCDCON — The LCD Control Register ..... 79
  - 5.10.2 PALLSW Least Significant Word — LCD Palette Register ..... 80
  - 5.10.3 PALMSW Most Significant Word — LCD Palette Register ..... 81
  - 5.10.4 FBADDR LCD Frame Buffer Start Address ..... 81
- 5.11 SSI Register ..... 82
  - 5.11.1 SYNCIO Synchronous Serial ADC Interface Data Register ..... 82
- 5.12 STFCLR Clear all ‘Start Up Reason’ flags location ..... 83
- 5.13 End Of Interrupt Locations ..... 83
  - 5.13.1 BLEOI Battery Low End of Interrupt ..... 83
  - 5.13.2 MCEOI Media Changed End of Interrupt ..... 83
  - 5.13.3 TEOI Tick End of Interrupt Location ..... 83
  - 5.13.4 TC1EOI TC1 End of Interrupt Location ..... 83
  - 5.13.5 TC2EOI TC2 End of Interrupt Location ..... 84
  - 5.13.6 RTCEOI RTC Match End of Interrupt ..... 84
  - 5.13.7 UMSEOI UART1 Modem Status Changed End of Interrupt ..... 84
  - 5.13.8 COEOI Codec End of Interrupt Location ..... 84
  - 5.13.9 KBDEOI Keyboard End of Interrupt Location ..... 84
  - 5.13.10 SRXEOF End of Interrupt Location ..... 84
- 5.14 State Control Registers ..... 84
  - 5.14.1 STDBY Enter the Standby State Location ..... 84
  - 5.14.2 HALT Enter the Idle State Location ..... 84
- 5.15 SS2 Registers ..... 85
  - 5.15.1 SS2DR Synchronous Serial Interface 2 Data Register ..... 85
  - 5.15.2 SS2POP Synchronous Serial Interface 2 Pop Residual Byte ..... 85
- 5.16 DAI Register Definitions ..... 85
  - 5.16.1 DAIR DAI Control Register ..... 86
    - 5.16.1.1 DAI Enable (DAIEN) ..... 87
    - 5.16.1.2 DAI Interrupt Generation ..... 87
    - 5.16.1.3 Left Channel Transmit FIFO Interrupt Mask (LCTM) ..... 87
    - 5.16.1.4 Left Channel Receive FIFO Interrupt Mask (LARM) ..... 87
    - 5.16.1.5 Right Channel Transmit FIFO Interrupt Mask (RCTM) ..... 87
    - 5.16.1.6 Right Channel Receive FIFO Interrupt Mask (RCRM) ..... 88
    - 5.16.1.7 Loopback Mode (LBM) ..... 88
  - 5.16.2 DAI Data Registers ..... 89
    - 5.16.2.1 DAIDR0 DAI Data Register 0 ..... 89
    - 5.16.2.2 DAIDR1 DAI Data Register 1 ..... 90
    - 5.16.2.3 DAIDR2 DAI Data Register 2 ..... 91
  - 5.16.3 DAISR DAI Status Register ..... 92
    - 5.16.3.1 Right Channel Transmit FIFO Service Request Flag (RCTS) ..... 94
    - 5.16.3.2 Right Channel Receive FIFO Service Request Flag (RCRS) ..... 94
    - 5.16.3.3 Left Channel Transmit FIFO Service Request Flag (LCTS) ..... 94

---

5.16.3.4 Left Channel Receive FIFO Service Request Flag (LCRS) .....	94
5.16.3.5 Right Channel Transmit FIFO Underrun Status (RCTU) .....	94
5.16.3.6 Right Channel Receive FIFO Overrun Status (RCRO) .....	94
5.16.3.7 Left Channel Transmit FIFO Underrun Status (LCTU) .....	95
5.16.3.8 Left Channel Receive FIFO Overrun Status (LCRO) .....	95
5.16.3.9 Right Channel Transmit FIFO Not Full Flag (RCNF) .....	95
5.16.3.10 Right Channel Receive FIFO Not Empty Flag (RCNE) .....	95
5.16.3.11 Left Channel Transmit FIFO Not Full Flag (LCNF) .....	95
5.16.3.12 Left Channel Receive FIFO Not Empty Flag (LCNE) .....	95
5.16.3.13 FIFO Operation Completed Flag (FIFO) .....	95
<b>6. ELECTRICAL SPECIFICATIONS .....</b>	<b>96</b>
6.1 Absolute Maximum Ratings .....	96
6.2 Recommended Operating Conditions .....	96
6.3 DC Characteristics .....	96
6.4 AC Characteristics .....	98
6.5 I/O Buffer Characteristics .....	110
6.6 JTAG Boundary Scan Signal Ordering .....	111
<b>7. TEST MODES .....</b>	<b>114</b>
7.1 Oscillator and PLL Bypass Mode .....	114
7.2 Oscillator and PLL Test Mode .....	114
7.3 Debug / ICE Test Mode .....	115
7.4 Hi-Z (System) Test Mode .....	115
7.5 Software Selectable Test Functionality .....	115
<b>8. PIN INFORMATION .....</b>	<b>116</b>
8.1 208-Pin LQFP Pin Diagram .....	116
8.2 208-Pin LQFP Numeric Pin Listing .....	117
8.3 256-Pin PBGA Pin Diagram .....	120
8.4 256-Ball PBGA Ball Listing .....	121
<b>9. PACKAGE SPECIFICATIONS .....</b>	<b>125</b>
9.1 208-Pin LQFP Package Outline Drawing .....	125
9.2 EP7212 256-Ball PBGA (17 × 17 × 1.53-mm Body) Dimensions .....	126
<b>10. ORDERING INFORMATION .....</b>	<b>127</b>
<b>11. APPENDIX A: BOOT CODE .....</b>	<b>128</b>
<b>12. INDEX .....</b>	<b>133</b>

**LIST OF FIGURES**

Figure 1. 208-Pin LQFP (Low Profile Quad Flat Pack) Pin Diagram .....	13
Figure 2. EP7212 Block Diagram.....	20
Figure 3. State Diagram .....	21
Figure 4. CLKEN Timing Entering the Standby State .....	26
Figure 5. CLKEN Timing Entering the Standby State .....	26
Figure 6. Codec Interrupt Timing .....	40
Figure 7. DAI Interface .....	41
Figure 8. EP7212 Rev C - Digital Audio Interface Timing – MSB / Left Justified format.....	42
Figure 9. SSI2 Port Directions in Slave and Master Mode.....	44
Figure 10. Residual Byte Reading .....	45
Figure 11. Video Buffer Mapping .....	48
Figure 12. A Maximum EP7212 Based System.....	52
Figure 13. Consecutive Memory Read Cycles with Minimum Wait States .....	100
Figure 14. Sequential Page Mode Read Cycles with Minimum Wait States.....	101
Figure 15. Consecutive Memory Write Cycles with Minimum Wait States.....	102
Figure 16. DRAM Read Cycles at 13 MHz and 18.432 MHz .....	103
Figure 17. DRAM Read Cycles at 36 MHz.....	104
Figure 18. DRAM Write Cycles at 13 MHz and 18 MHz .....	105
Figure 19. DRAM Write Cycles at 36 MHz.....	106
Figure 20. Video Quad Word Read from DRAM at 13 MHz and 18 MHz .....	107
Figure 21. Quad Word Read from DRAM at 36 MHz.....	107
Figure 22. DRAM CAS Before RAS Refresh Cycle at 13 MHz and 18 MHz.....	108
Figure 23. DRAM CAS Before RAS Refresh Cycle at 36 MHz.....	109
Figure 24. LCD Controller Timings.....	109
Figure 25. SSI Interface for AD7811/2.....	110
Figure 26. SSI2 Interface Timings.....	110
Figure 27. 208-Pin LQFP (Low Profile Quad Flat Pack) Pin Diagram .....	116
Figure 28. 256-Ball Plastic Ball Grid Array Diagram .....	120

**LIST OF TABLES**

Table 1. Acronyms and Abbreviations .....	11
Table 2. Unit of Measurement.....	12
Table 3. Pin Description Conventions.....	12
Table 4. External Signal Functions .....	14
Table 5. SSI/Codec/DAI Pin Multiplexing.....	18
Table 6. Output Bi-Directional Pins .....	18
Table 7. Peripheral Status in Different Power Management States.....	22
Table 8. Exception Priority Handling.....	27
Table 9. Interrupt Allocation in the First Interrupt Register.....	28
Table 10. Interrupt Allocation in the Second Interrupt Register .....	28
Table 11. Interrupt Allocation in the Third Interrupt Register .....	28
Table 12. External Interrupt Source Latencies.....	30
Table 13. Chip Select Address Ranges After Boot From On-Chip Boot ROM.....	30
Table 14. Boot Options .....	31
Table 15. Physical to DRAM Address Mapping .....	32
Table 16. DRAM Address Mapping When Connected to an External 32-Bit DRAM Memory System .....	33
Table 17. CL-PS6700 Memory Map.....	34
Table 18. Space Field Decoding.....	34

Table 19. Effect of Endianness on Read Operations .....	37
Table 20. Effect of Endianness on Write Operations .....	37
Table 21. Serial Interface Options .....	39
Table 22. Serial-Pin Assignments .....	39
Table 23. ADC Interface Operation Frequencies .....	43
Table 24. Instructions Supported in JTAG Mode .....	50
Table 25. Device ID Register .....	51
Table 26. EP7212 Memory Map in External Boot Mode .....	53
Table 27. EP7212 Internal Registers (Little Endian Mode) .....	55
Table 28. EP7212 Internal Registers (Big Endian Mode).....	57
Table 29. SYSCON1 .....	59
Table 30. SYSCON2 .....	61
Table 31. SYSCON3 .....	63
Table 32. SYSFLG .....	64
Table 33. SYSFLG2 .....	66
Table 34. INTSR1.....	67
Table 35. INSTR2.....	69
Table 36. INTSR3.....	70
Table 37. Values of the Bus Width Field .....	72
Table 38. Values of the Wait State Field at 13 MHz and 18 MHz .....	72
Table 39. Values of the Wait State Field at 36 MHz.....	72
Table 40. MEMCFG .....	73
Table 41. LED Flash Rates .....	75
Table 42. LED Duty Ratio.....	75
Table 43. PMPCON.....	76
Table 44. Sense of PWM control lines .....	76
Table 45. UARTDR1-2 UART1-2 .....	77
Table 46. UBRLCR1-2 UART1-2 .....	78
Table 47. LCDCON .....	79
Table 48. Grayscale Value to Color Mapping.....	81
Table 49. SYNCIO.....	82
Table 50. DAI Control Register .....	86
Table 51. DAI Data Register 0 .....	89
Table 52. DAI Data Register 1 .....	90
Table 53. DAI Data Register 2 .....	91
Table 54. DAI Control, Data and Status Register Locations .....	92
Table 55. absolute Maximum Ratings .....	96
Table 56. Recommended Operating Conditions .....	96
Table 57. DC Characteristics .....	96
Table 58. AC Timing Characteristics.....	98
Table 59. Timing Characteristics.....	99
Table 60. I/O Buffer Output Characteristics .....	111
Table 61. 208-Pin LQFP Numeric Pin Listing.....	111
Table 62. EP7212 Hardware Test Modes .....	114
Table 63. Oscillator and PLL Test Mode Signals .....	115
Table 64. Software Selectable Test Functionality .....	115
Table 65. 208-Pin LQFP Numeric Pin Listing.....	117
Table 66. 256-Ball PBGA Ball Listing.....	121

## 1. CONVENTIONS

This section presents acronyms, abbreviations, units of measurement, and conventions used in this data sheet.

### 1.1 Acronyms and Abbreviations

Table 1 lists abbreviations and acronyms used in this data sheet.

Acronym/ Abbreviation	Definition
AC	alternating current.
A/D	analog-to-digital.
ADC	analog-to-digital converter.
CMOS	complementary metal oxide semiconductor.
CODEC	coder / decoder.
CPU	central processing unit.
D/A	digital-to-analog.
DC	direct current.
DMA	direct-memory access.
EPB	embedded peripheral bus.
FCS	frame check sequence.
FIFO	first in / first out.
GPIO	general purpose I/O.
ICT	in circuit test.
IR	infrared.
IrDA	Infrared Data Association.
JTAG	Joint Test Action Group.
LCD	liquid crystal display.
LED	light-emitting diode.
LQFP	low profile quad flat pack.
LSB	least significant bit.
MIPS	millions of instructions per second.
MMU	memory management unit.
MSB	most significant bit.
PBGA	plastic ball grid array.
PCB	printed circuit board.
PDA	personal digital assistant.

**Table 1. Acronyms and Abbreviations**

Acronym/ Abbreviation	Definition
PIA	peripheral interface adapter.
PLL	phase locked loop.
PSU	power supply unit.
p/u	pull-up resistor.
RAM	random access memory.
RISC	reduced instruction set computer.
ROM	read-only memory.
RTC	Real Time Clock.
SIR	slow (9600–115.2 kbps) infrared.
SRAM	static random access memory.
SSI	synchronous serial interface.
TAP	test access port.
TLB	translation lookaside buffer.
UART	universal asynchronous receiver.

**Table 1. Acronyms and Abbreviations (cont.)**

## 1.2 Units of Measurement

Symbol	Unit of Measure
°C	degree Celsius
Hz	hertz (cycle per second)
kbits/s	kilobits per second
kbyte	kilobyte (1,024 bytes)
kHz	kilohertz
kΩ	kilohm
Mbps	megabits (1,048,576 bits) per second
Mbyte	megabyte (1,048,576 bytes)
MHz	megahertz (1,000 kilohertz)
μA	microampere
μF	microfarad
μW	microwatt
μs	microsecond (1,000 nanoseconds)
mA	milliampere
mW	milliwatt
ms	millisecond (1,000 microseconds)
ns	nanosecond
V	volt
W	watt

**Table 2. Unit of Measurement**

## 1.3 General Conventions

Hexadecimal numbers are presented with all letters in uppercase and a lowercase ‘h’ appended or with

a 0x at the beginning. For example, 0x14 and 03CAh are hexadecimal numbers. Binary numbers are enclosed in single quotation marks when in text (for example, ‘11’ designates a binary number). Numbers not indicated by an ‘h’, 0x or quotation marks are decimal.

Registers are referred to by acronym, as listed in the tables on the previous page, with bits listed in brackets MSB-to-LSB separated by a colon (:) (for example, CODR[7:0]), or LSB-to-MSB separated by a hyphen (for example, CODR[0–2]).

The use of ‘td’ indicates values that are ‘to be determined’, ‘n/a’ designates ‘not available’, and ‘n/c’ indicates a pin that is a ‘no connect’.

## 1.4 Pin Description Conventions

Abbreviations used for signal directions are listed in [Table 3](#).

Abbreviation	Direction
I	Input
O	Output
I/O	Input or Output

**Table 3. Pin Description Conventions**

## 2. PIN INFORMATION

### 2.1 208-Pin LQFP Pin Diagram

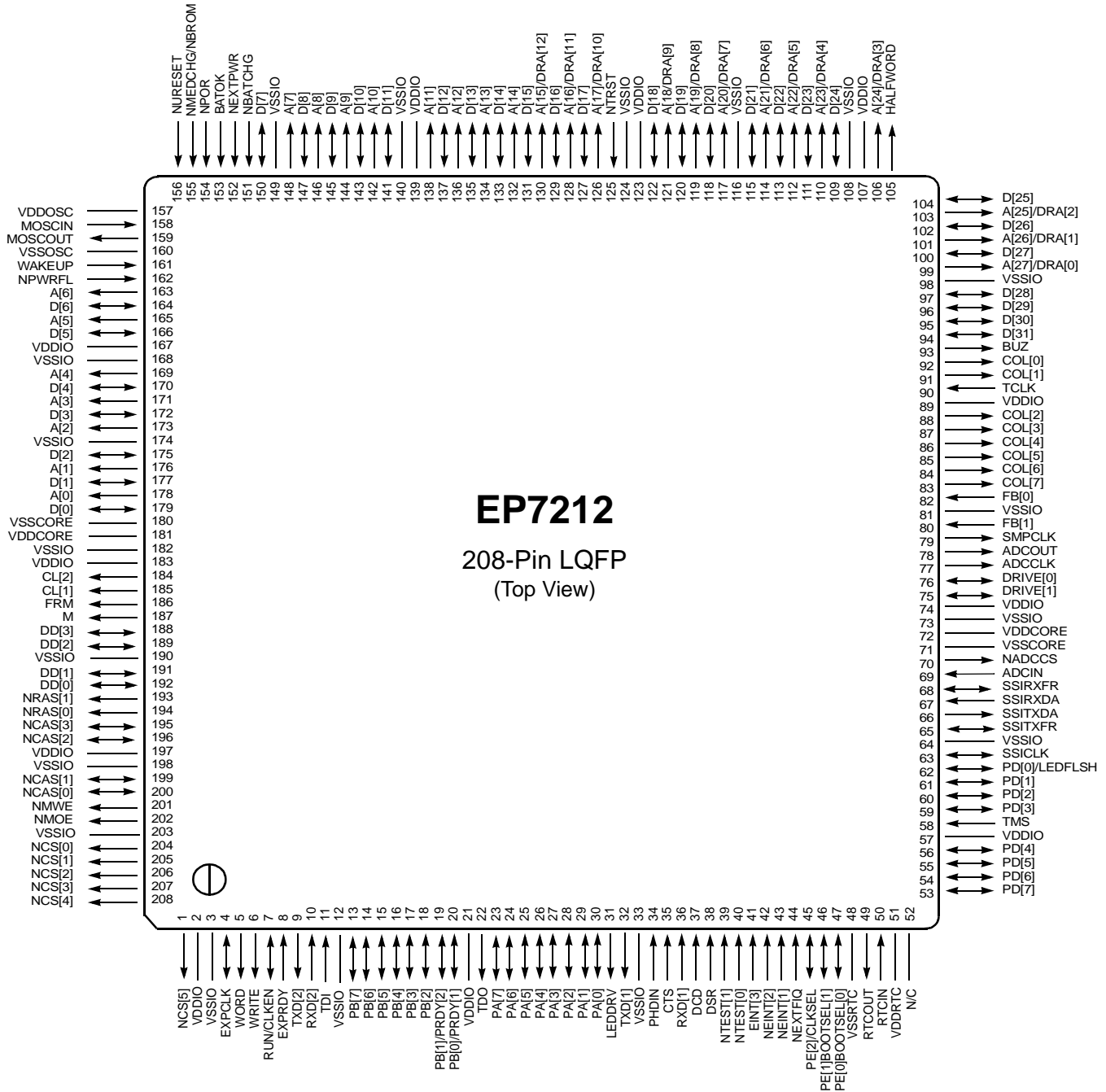

- Notes:
- 1) For package specifications, please see *208-Pin LQFP Package Outline Drawing* on page 125
  - 2) N/C should not be grounded but left as no connects

**Figure 1. 208-Pin LQFP (Low Profile Quad Flat Pack) Pin Diagram**

## 2.2 Pin Descriptions

Table 4 describes the function of all the external signals to the EP7212. Note that all output signals and all I/O pins (when acting as outputs) are three stateable. This is to enable the Hi-Z test modes to be supported.

### 2.2.1 External Signal Functions

Function	Signal Name	Signal	Description												
Data bus	D[0-31]	I/O	32-bit system data bus for memory, DRAM, and I/O interface												
Address bus	A[0-14]	O	15 bits of system byte address during memory and expansion cycles												
	A[15-27] DRA[0-12]		DRA[0-12] is multiplexed with A[15-27], offering additional power savings since the lightest loading is expected on the high order ROM address lines. Whenever the EP7212 is in the Standby State, the external address and data buses are driven low. The RUN signal is used internally to force these buses to be driven low. This is done to prevent peripherals that are powered-down from draining current. Also, the internal peripheral's signals get set to their Reset State.												
Memory Interface	nRAS[0-1]	O	Row Address Select outputs to DRAM banks 0 to 1.												
	nCAS[0-3]	I/O	Column Address Select outputs allowing for bytes 0 to 3 within a 32-bit word.												
	nMOE	O	Memory output enable												
	nMWE	O	Memory write enable												
	nCS[0-3]	O	Chip select; active low, SRAM-like chip selects for expansion												
	nCS[4-5]	O	Chip select; active low, CS for expansion or for CL-PS6700 select												
	EXPRDY	I	Expansion port ready; external expansion devices drive this low to extend the bus cycle. This is used to insert wait states for an external bus cycle.												
	WRITE	O	Write strobe, low during reads, high during writes from the EP7212												
	WORD/ HALFWORD	O	To do write accesses of different sizes Word and Half-Word must be externally decoded. The encoding of these signals is as follows:												
				<table border="1"> <thead> <tr> <th>Access Size</th> <th>Word</th> <th>Half-Word</th> </tr> </thead> <tbody> <tr> <td>Word</td> <td>1</td> <td>0</td> </tr> <tr> <td>Half-Word</td> <td>*</td> <td>1</td> </tr> <tr> <td>Byte</td> <td>0</td> <td>0</td> </tr> </tbody> </table>	Access Size	Word	Half-Word	Word	1	0	Half-Word	*	1	Byte	0
Access Size	Word	Half-Word													
Word	1	0													
Half-Word	*	1													
Byte	0	0													
	EXPCLK	I/O	Expansion clock rate is the same as the CPU clock for 13 MHz and 18 MHz. It runs at 36.864 MHz for 36,49 and 74 MHz modes; in 13 MHz mode this pin is used as the clock input.												

**Table 4. External Signal Functions**

Function	Signal Name	Signal	Description
Interrupts	nMEDCHG/ nBROM	I	Media changed input; active low, deglitched. Used as a general purpose FIQ interrupt during normal operation. It is also used on power up to configure the processor to either boot from the internal Boot ROM, or from external memory. When low, the chip will boot from the internal Boot ROM.
	nEXTFIQ	I	External active low fast interrupt request input
	EINT[3]	I	External active high interrupt request input
	nEINT[1:2]	I	Two general purpose, active low interrupt inputs
Power Management	nPWRFL <sup>1</sup>	I	Power fail input; active low, deglitched input to force system into the Standby State
	BATOK <sup>1</sup>	I	Main battery OK input; falling edge generates a FIQ, a low level in the Standby State inhibits system start up; deglitched input
	nEXTPWR	I	External power sense; must be driven low if the system is powered by an external source
	nBATCHG <sup>1</sup>	I	New battery sense; driven low if battery voltage falls below the "no-battery" threshold; it is a deglitched input
State Control	nPOR	I	Power-on reset input. This signal is not deglitched. When active it completely resets the entire system, including all the RTC registers. Upon power-up, the signal must be held active low for a minimum of 100 $\mu$ sec after $V_{DD}$ has settled. During normal operation, nPOR needs to be held low for at least one clock cycle of the selected clock speed (i.e., when running at 13 MHz, the pulse width of nPOR needs to be > 77 nsec).  Note that nURESET, RUN/CLKEN, TEST(0), TEST(1), PE(0), PE(1), PE(2), DRIVE(0), DRIVE(1), DD(0), DD(1), DD(2), and DD(3) are all latched on the rising edge of nPOR.
	RUN/CLKEN	I/O	This pin is programmed to either output the RUN signal or the CLKEN signal. The CLKENSL bit is used to configure this pin. When RUN is selected, the pin will be high when the system is active or idle, low while in the Standby State. When CLKEN is selected, the pin will only be driven low when in the Standby State (For RUN, see <a href="#">Table 6</a> ).
	WAKEUP <sup>1</sup>	I	Wake up is a deglitched input signal. It must also be held high for at least 125 $\mu$ sec to guarantee its detection. Once detected it forces the system into the Operating State from the Standby State. It is only active when the system is in the Standby State. This pin is ignored when the system is in the Idle or Operating State. It is used to wakeup the system after first power-up, or after software has forced the system into the Standby State. WAKEUP will be ignored for up to two seconds after nPOR goes HIGH. Therefore, the external WAKEUP logic must be designed to allow it to rise and stay HIGH for at least 125 usec, two seconds after nPOR goes HIGH.
	nURESET <sup>1</sup>	I	User reset input; active low deglitched input from user reset button. This pin is also latched upon the rising edge of nPOR and read along with the input pins nTEST[0-1] to force the device into special test modes. nURESET does not reset the RTC.

**Table 4. External Signal Functions (cont.)**

Function	Signal Name	Signal	Description
DAI, Codec or SSI2 Interface (See <a href="#">Table 5</a> for pin assignment and direction following multiplexing)	SSICLK	I/O	DAI/Codec/SSI2 clock signal
	SSITXFR	I/O	DAI/Codec/SSI2 serial data output frame/synchronization pulse output
	SSITXDA	O	DAI/Codec/SSI2 serial data output
	SSIRXDA	I	DAI/Codec/SSI2 serial data input
	SSIRXFR	I/O	SSI2 serial data input frame/synchronization pulse DAI external clock input
ADC Interface (SSI1)	ADCCLK	O	Serial clock output
	nADCCS	O	Chip select for ADC interface
	ADCOUT	O	Serial data output
	ADCIN	I	Serial data input
	SMPCLK	O	Sample clock output
IrDA and RS232 Interfaces	LEDDRIV	O	Infrared LED drive output (UART1)
	PHDIN	I	Photo diode input (UART1)
	TXD[1-2]	O	RS232 UART1 and 2 TX outputs
	RXD[1-2]	I	RS232 UART1 and 2 RX inputs
	DSR	I	RS232 DSR input
	DCD	I	RS232 DCD input
	CTS	I	RS232 CTS input
LCD	DD[0-3]	I/O	LCD serial display data; pins can be used on power up to read the ID of some LCD modules (See <a href="#">Table 6</a> ).
	CL[1]	O	LCD line clock
	CL[2]	O	LCD pixel clock
	FRM	O	LCD frame synchronization pulse output
	M	O	LCD AC bias drive
Keyboard & Buzzer drive LED Flasher	COL[0-7]	O	Keyboard column drives (SYSCON1)
	BUZ	O	Buzzer drive output (SYSCON1)
	PD[0]/LEDFLSH	O	LED flasher driver — multiplexed with Port D bit 0. This pin can provide up to 4 mA of drive current.

**Table 4. External Signal Functions (cont.)**

Function	Signal Name	Signal	Description
General Purpose I/O	PA[0:7]	I/O	Port A I/O (bit 6 for boot clock option, bit 7 for CL-PS6700 PRDY input); also used as keyboard row inputs
	PB[0]/PRDY1 PB[1]/PRDY2 PB[2:7]	I/O	Port B I/O. All eight Port B bits can be used as GPIOs. When the PC CARD1 or 2 control bits in the SYSCON2 register are de-asserted, PB[0] and PB[1] are available for GPIO. When asserted, these port bits are used as the PRDY signals for connected CL-PS6700 PC Card Host Adapter devices.
	PD[0:7]	I/O	Port D I/O
	PE[0]/ BOOTSEL[0]	I/O	Port E I/O (3 bits only). Can be used as general purpose I/O during normal operation.
	PE[1]/ BOOTSEL[1]	I/O	During power-on reset, PE[0] and PE[1] are inputs and are latched by the rising edge of nPOR to select the memory width that the EP7212 will use to read from the boot code storage device (i.e., external 8-bit-wide FLASH bank).
	PE[2]/ CLKSEL	I/O	During power-on reset, PE[2] is latched by the rising edge of nPOR to select the clock mode of operation (i.e., either the PLL or external 13 MHz clock mode).
PWM Drives	DRIVE[0:1]	I/O	PWM drive outputs. These pins are inputs on power up to determine what polarity the output of the PWM should be when active. Otherwise, these pins are always an output (See <a href="#">Table 6</a> ).
	FB[0:1]	I	PWM feedback inputs
Boundary Scan	TDI	I	JTAG data in
	TDO	O	JTAG data out
	TMS	I	JTAG mode select
	TCLK	I	JTAG clock
	nTRST	I	JTAG async reset
Test	nTEST[0:1]	I	Test mode select inputs. These pins are used in conjunction with the power-on latched state of nURESET to select between the various device test models.
Oscillators	MOSCIN MOSCOU	I O	Main 3.6864 MHz oscillator for 18.432 MHz–73.728 MHz PLL
	RTCIN RTCOU	I O	Real Time Clock 32.768 kHz oscillator
	No Connects	N/C	No connects should be left as no connects; do not connect to ground

**Table 4. External Signal Functions (cont.)**

1. All deglitched inputs are via the 16.384 kHz clock. Each deglitched signal must be held active for at least two clock periods. Therefore, the input signal must be active for at least ~125  $\mu$ s to be detected cleanly.

The RTC crystal must be populated for the device to function properly.

### 2.2.2 SSI/Codec/DAI Pin Multiplexing

SSI2	Codec	DAI	Direction	Strength
SSICLK	PCMCLK	SCLK	I/O	1
SSITXFR	PCMSYNC	LRCK	I/O	1
SSITXDA	PCMOUT	SDOUT	Output	1
SSIRXDA	PCMIN	SDIN	Input	
SSIRXFR	p/u*	MCLK	I/O	1

\* p/u = use an ~10 k pull-up

The selection between SSI2 and the codec is controlled by the state of the SERSEL bit in SYSCON2 (See *SYSCON2 System Control Register 2*). The choice between the SSI2, codec, and the DAI is controlled by the DAISEL bit in SYSCON3 (See *SYSCON3 System Control Register 3*).

**Table 5. SSI/Codec/DAI Pin Multiplexing**

### 2.2.3 Output Bi-Directional Pins

RUN	The RUN pin is looped back in to skew the address and data bus from each other.
nCAS[3:0]	The nCAS pins are looped back into the EP7212 to be used as the actual clock source for the data to be latched internally.
Drive [0-1]	Drive 0 and 1 are looped back in on power up to determine what polarity the output of the PWM should be when active.
DD[3:0]	DD[3:0] are looped back in on power up to enable the reading of the ID of some LCD modules.

**NOTE:** The above output pins are implemented as bi-directional pins to enable the output side of the pad to be monitored and hence provide more accurate control of timing or duration.

**Table 6. Output Bi-Directional Pins**

### 3. FUNCTIONAL DESCRIPTION

The EP7212 device is a single-chip embedded controller designed to be used in low-cost and ultra-low-power applications. Operating at 74 MHz, the EP7212 delivers approximately 66 Dhrystone 2.1 MIPS of sustained performance (74 MIPS peak). This is approximately the same as a 100 MHz Pentium-based PC.

The EP7212 contains the following functional blocks:

- ARM720T processor which consists of the following functional sub-blocks:
  - ARM7TDMI CPU core (which supports the logic for the Thumb instruction set, core debug, enhanced multiplier, JTAG, and the Embedded ICE) running at a dynamically programmable clock speed of 18 MHz, 36 MHz, 49 MHz, or 74 MHz.
  - Memory Management Unit (MMU) compatible with the ARM710 core (providing address translation and a 64-entry translation lookaside buffer) with added support for Windows CE.
  - 8 kbytes of unified instruction and data cache with a four-way set associative cache controller.
  - Write buffer
- 38,400 bytes (0x9600) of on-chip SRAM that can be shared between the LCD controller and general application use.
- Memory interfaces for up to 6 independent 256 Mbyte expansion segments with programming wait states.
- 27 bits of general purpose I/O - multiplexed to provide additional functionality where necessary.
- Digital Audio Interface (DAI) for connection to CD-quality DACs and codecs.
- Interrupt controller
- Advanced system state control and power management.
- Two full-duplex 16550A compatible UARTs with 16-byte transmit and receive FIFOs.
- IrDA SIR protocol controller capable of speeds up to 115.2 kbps.
- Programmable 1-, 2-, or 4-bit-per-pixel LCD controller with 16-level grayscale.
- Programmable frame buffer start address, allowing a system to be built using only internal SRAM for memory.
- On-chip boot ROM programmed with serial load boot sequence.
- Two 16-bit general purpose timer counters.
- A 32-bit Real Time Clock (RTC) and comparator.
- Dedicated LED flasher pin driven from the RTC with programmable duty ratio (multiplexed with a GPIO pin).
- Two synchronous serial interfaces for Micro-wire or SPI peripherals such as ADCs, one supporting both the master and slave mode and the other supporting only the master mode.
- Full JTAG boundary scan and Embedded ICE support.
- Two programmable pulse-width modulation interfaces.
- An interface to one or two Cirrus Logic CL-PS6700 PC Card controller devices to support two PC Card slots.
- EDO DRAM support (Fast Page DRAM is only supported at 13 MHz and 18 MHz. It can interface up to two banks of DRAM. Each bank can be up to 256 Mbytes in size. The DRAM interface is programmable to be 16-bit or 32-bit wide.

- Oscillator and phase-locked loop (PLL) to generate the core clock speeds of 18.432 MHz, 36.864 MHz, 49.152 MHz, and 73.728 MHz from an external 3.6864 MHz crystal, with an alternative external clock input (used in 13 MHz mode).
- A low power 32.768 kHz oscillator.

The EP7212 design is optimized for low power dissipation and is fabricated on a fully static 0.25 micron CMOS process. It is available in a 256-ball PBGA or a 208-pin LQFP package.

Figure 2 shows a simplified block diagram of the EP7212. All external memory and peripheral devices are connected to the 32-bit data bus using the external 28-bit address bus and control signals.

### 3.1 CPU Core

The ARM720T consists of an ARM7TDMI 32-bit RISC processor, a unified cache, and a memory management unit (MMU). The cache is four-way set associative with 8-kbytes organized as 512 lines of 4 words. The cache is directly connected to the ARM7TDMI, and therefore caches the virtual address from the CPU. When the cache misses, the MMU translates the virtual address into a physical address. A 64-entry translation lookaside buffer (TLB) is utilized to speed the address translation process and reduce bus traffic necessary to read the page table. The MMU saves power by only translating the cache misses.

See the ARM720T Data sheet for a complete description of the various logic blocks that make up the processor, as well as all internal register information.

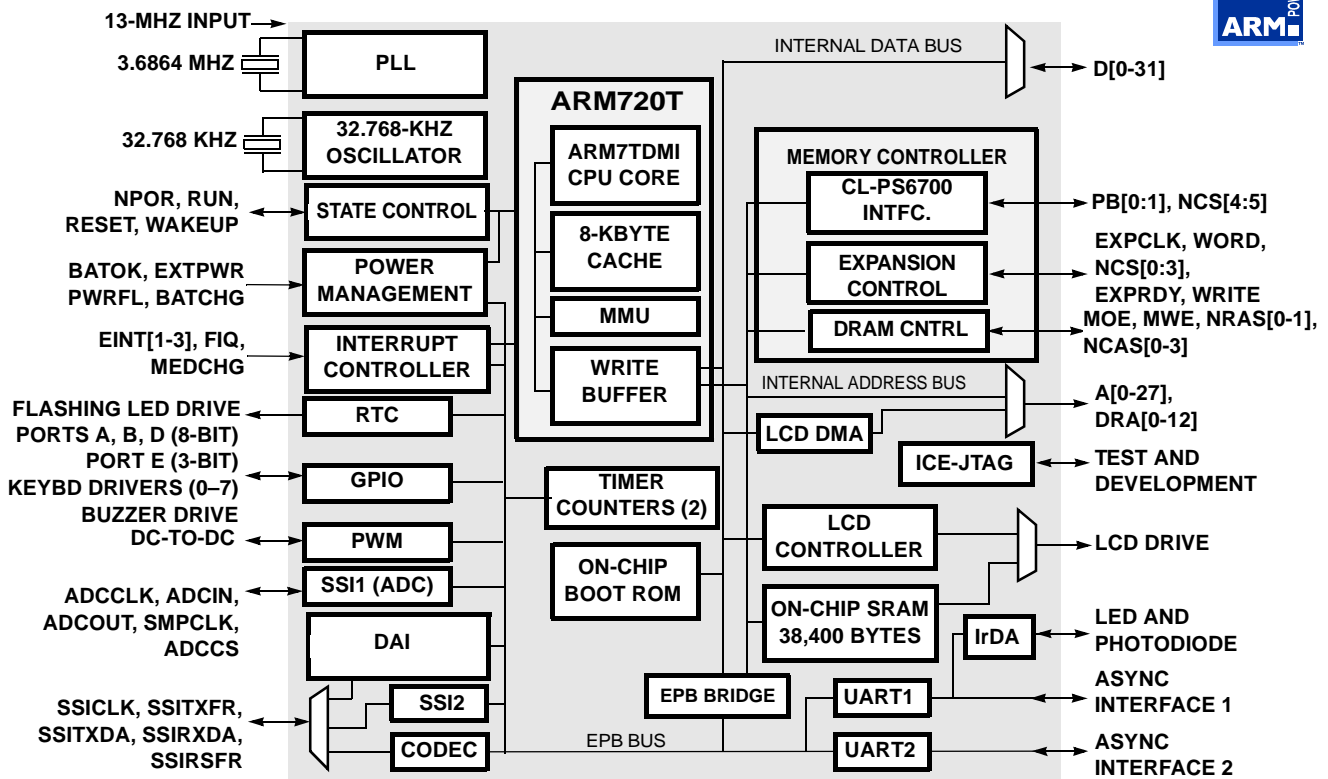
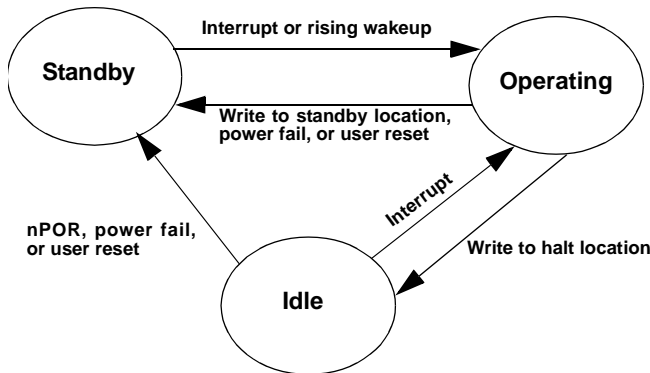

Figure 2. EP7212 Block Diagram

### 3.2 State Control

The EP7212 supports the following Power Management States: Operating, Idle, and Standby (see Figure 3). The normal program execution state is the Operating State; this is a full performance state where all of the clocks and peripheral logic are enabled. The Idle State is the same as the Operating State with the exception of the CPU clock being halted, and an interrupt or wakeup will return it back to the Operating State. The Standby State has the lowest power consumption of the three states. By selecting this mode the main oscillator shuts down, leaving only the Real Time Clock and its associated logic powered. It is important when the EP7212 is in Standby that all power and ground pins remain connected to power and ground in order to have a proper system wake-up. The only state that Standby can transition to is the Operating State.



**Figure 3. State Diagram**

In the description below, the RUN/CLKEN pin can be used either for the RUN functionality, or the CLKEN functionality to allow an external oscillator to be disabled in the 13 MHz mode. Either RUN or CLKEN functionality can be selected according to the state of the CLKENSL bit in the SYSCON2 register. Table 7 on the following page shows peripheral status in various power management states.

#### 3.2.1 Standby State

The Standby State equates to the system being switched "off" (i.e., no display, and the main oscillator is shut down). When the 18.432–73.72 MHz mode is selected, the PLL will be shut down. In the 13 MHz mode, if the CLKENSL bit is set low, then the CLKEN signal will be forced low and can, if required, be used to disable an external oscillator.

In the Standby State, all the system memory and state is maintained and the system time is kept up-to-date. The PLL/on-chip oscillator or external oscillator is disabled and the system is static, except for the low power watch crystal (32 kHz) oscillator and divider chain to the RTC and LED flasher. The RUN signal is driven low, therefore this signal can be used externally in the system to power down other system modules.

Whenever the EP7212 is in the Standby State, the external address and data buses are forced low internally by the RUN signal. This is done to prevent peripherals that are powered down from draining current. Also, the internal peripheral's signals get set to their Reset State.

When first powered, or reset by the nPOR (Power On Reset, active low) signal, the EP7212 is forced into the Standby State. This is known as a cold reset, and when leaving the Standby State after a cold reset, external wake up is the only way to wake up the device. When leaving the Standby State after non-cold reset conditions (i.e., the software has forced the device into the Standby State), the transition to the Operating State can be caused by a rising edge on the WAKEUP input signal or by an enabled interrupt. Normally, when entering the Standby State from the Operating State, the software will leave some interrupt sources enabled.

**NOTE:** The CPU cannot be awakened by the TINT, WEINT, and BLINT interrupts when in the Standby State.

Typically, software writes to the Standby internal memory location to cause the transition from the

Address (W/B)	Operating	Idle	Standby	nPOR RESET	nURESET RESET
DRAM Control	On	On	SELFREF	Off	SELFREF
UARTs	On	On	Off	Reset	Reset
LCD FIFO	On	On	Reset	Reset	Reset
LCD	On	On	Off	Reset	Reset
ADC Interface	On	On	Off	Reset	Reset
SSI2 Interface	On	On	Off	Reset	Reset
DAI Interface	On	On	Off	Reset	Reset
Codec	On	On	Off	Reset	Reset
Timers	On	On	Off	Reset	Reset
RTC	On	On	On	On	On
LED Flasher	On	On	On	Reset	Reset
DC-to-DC	On	On	Off	Reset	Reset
CPU	On	Off	Off	Reset	Reset
Interrupt Control	On	On	On	Reset	Reset
PLL/CLKEN Signal	On	On	Off	Off	Off

**Table 7. Peripheral Status in Different Power Management States**

Operating State to the Standby State. Before entering the Standby State, if external I/O devices (such as the CL-PS6700s connected to nCS[4] or nCS[5]) are in use, the software must check to ensure that they are idle before issuing the write to the Standby State location.

Before entering the Standby State, the software must properly disable the DAI. Failing to do so will result in higher than expected power consumption in the Standby State, as well as unpredictable operation of the DAI. The DAI can be re-enabled after transitioning back to the Operating State.

The system can also be forced into the Standby State by hardware if the nPWRFL or nURESET inputs are forced low. The only exit from the Standby State is to the Operating State.

The system will only transition to the Operating State from the Standby State under the following conditions: when the nPWRFL input pin is high when the nEXTPWR input pin is low or when the BATOK input pin is high. This prevents the system

from starting when the power supply is inadequate (i.e., the main batteries are low), corresponding to a low level on nPWRFL or BATOK.

From the Standby State, if the WAKEUP signal is applied with no clock except the 32 kHz clock running, the EP7212 will be initialized into a state where it is ready to start and is waiting for the CPU to start receiving its clock. The CPU will still be held in reset at this point. After the first clock is applied, there will be a delay of about eight clock cycles before the CPU is enabled. This delay is to allow the clock to the CPU time to settle.

### 3.2.1.1 *UART in Standby State*

During the Standby State, the UARTs are disabled and cannot detect any activity (i.e., start bit) on the receiver. If this functionality is required then this can be accomplished in software by the following method:

- 1) Permanently connect the RX pin to one of the active low external interrupt pins.

- 2) Ensure that on entry to the Standby State, the chosen interrupt source is not masked, and the UART is enabled.
- 3) Send a preamble that consists of one start bit, 8 bits of zero, and one stop bit. This will cause the EP7212 to wake and execute the enabled interrupt vector.

The UART will automatically be re-enabled when the processor re-enters the Operating State, and the preamble will be received. Since the UART was not awake at the start of the preamble, the timing of the sample point will be off-center during the preamble byte. However, the next byte transmitted will be correctly aligned. Thus, the actual first real byte to be received by the UART will get captured correctly.

### 3.2.2 Idle State

If in the Operating State, the Idle State can be entered by writing to a special internal memory location (HALT) in the EP7212. If an interrupt occurs, the EP7212 will return immediately back to the Operating State and execute the next instruction. The WAKEUP signal can not be used to exit the Idle State. It is only used to exit the Standby State.

In the Idle State, the device functions just like it does when in the Operating State. However, the CPU clock is halted while it waits for an event such as a key press to generate an interrupt. The PLL (in 18.432–73.728 MHz mode) or the external 13 MHz clock source always remains active in the Idle State.

### 3.2.3 Keyboard Interrupt

For the case of the keyboard interrupt, the following options are available and are selectable according to bits 1 and 3 of the SYSCON2 register (refer to the *SYSCON2 Register Description* for details).

- If the KBWEN bit (SYSCON2 bit 3) is set low, then a keypress will cause a transition from a

power saving state only if the keyboard interrupt is non-masked (i.e., the interrupt mask register 2 (INTMR2 bit 0) is high).

- When KBWEN is high, a keypress will cause the device to wake up regardless of the state of the interrupt mask register. This is called the “Keyboard Direct Wakeup” mode. In this mode, the interrupt request may not get serviced. If the interrupt is masked (i.e., the interrupt mask register 2 (INTMR2 bit 0) is low), the processor simply starts re-executing code from where it left off before it entered the power saving state. If the interrupt is non-masked, then the processor will service the interrupt.
- When the KBD6 bit (SYSCON2 bit 1) is low, all 8 of Port A inputs are OR’ed together to produce the internal wakeup signal and keyboard interrupt request. This is the default reset state.
- When the KBD6 bit (SYSCON2 bit 1) is high, only the lowest 6 bits of Port A are OR’ed together to produce the internal wakeup signal and keyboard interrupt request. The two most significant bits of Port A are available as GPIO when this bit is set high.

In the case where KBWEN is low and the INTMR2 bit 0 is low, it will only be possible to wakeup the device by using the external WAKEUP pin or another enabled interrupt source. The keyboard interrupt capability allows an OS to use either a polled or interrupt-driven keyboard routine, or a combination of both.

**NOTE:** The keyboard interrupt is NOT deglitched.

## 3.3 Power-Up Sequence

The EP7212 has a power-up sequence that should be followed for proper start up. If any of the below recommended timing sequences are violated, then it is possible that the part may not start-up properly. This could cause the device to get lost and not recover without a hard reset.

1). Upon power, the signal nPOR must be held active (LOW) for a minimum of 100us, after  $V_{DD}$  has become settled.

2). After nPOR goes HIGH, the EP7212 will enter the Standby State (and only this state). In this state, the PLL is not enabled, and thus the CPU is not enabled either. The only method that can be used to allow the EP7212 to exit the Standby State into the Operating State is by the WAKEUP signal going active (HIGH).

**NOTE:** It is not a requirement to use the nURESET signal. If not used, the nURESET signal must be HIGH, and it must have gone HIGH prior to nPOR going HIGH. This is due to the fact that nURESET is latched into the device by the rising edge of nPOR. When nURESET is LOW on the rising edge of nPOR, it can force the device into one of its Test Mode states.

3). After nPOR goes HIGH, the WAKEUP signal cannot be detected as going HIGH, until after at least two seconds. After two seconds, the WAKEUP signal can become active, and it must be HIGH for at least 125us.

4). After the WAKEUP signal is detected internally, it first goes through a deglitching circuit. This is why it must be active for at least 125us. Then the PLL gets enabled. WAKEUP is ignored immediately after waking up the system. It also ignores it while in the Idle or Operating State. It can constantly toggle with no affect on the device. It will only be read again if nPOR goes low and then high again, or if software has forced the device back into the Standby State.

5). A maximum of 250 msec will pass before the CPU becomes enabled and starts to fetch the first instruction.

### 3.4 Resets

There are three asynchronous resets to the EP7212: nPOR, nPWRFL and nURESET. If any of these are active, a system reset is generated internally. This will reset all internal registers in the EP7212 except

the RTC data and match registers. These registers are only cleared by nPOR allowing the system time to be preserved through a user reset or power fail condition.

Any reset will also reset the CPU and cause it to start execution at the reset vector when the EP7212 returns to the Operating State.

Internal to the EP7212, three different signals are used to reset storage elements. These are nPOR, nSYSRES and nSTBY. nPOR is an external signal. nSTBY is equivalent to the external RUN signal.

nPOR (Power On Reset, active low) is the highest priority reset signal. When active (low), it will reset all storage elements in the EP7212. nPOR active forces nSYSRES and nSTBY active. nPOR will only be active after the EP7212 is first powered up and not during any other resets. nPOR active will clear all flags in the status register except for the cold reset flag (CLDFLG) bit (SYSFLG, bit 15), which is set.

nSYSRES (System Reset, active low) is generated internally to the EP7212 if nPOR, nPWRFL, or nURESET are active. It is the second highest priority reset signal, used to asynchronously reset most internal registers in the EP7212. nSYSRES active forces nSTBY and RUN low. nSYSRES is used to reset the EP7212 and force it into the Standby State with no co-operation from software. The CPU is also reset.

The nSTBY and RUN signals are high when the EP7212 is in the Operating or Idle States and low when in the Standby State. The main system clock is valid when nSTBY is high. The nSTBY signal will disable any peripheral block that is clocked from the master clock source (i.e., everything except for the RTC). In general, a system reset will clear all registers and nSTBY will disable all peripherals that require a main clock. The following peripherals are always disabled by a low level on nSTBY: two UARTs and IrDA SIR encoder, timer counters, telephony codec, and the two SSI inter-

faces. In addition, when in the Standby State, the LCD controller and PWM drive are also disabled.

When operating from an external 13 MHz oscillator which has become disabled in the Standby State by using the CLKEN (SYSCON, bit 13) signal (i.e., with CLKENSL = 0), the oscillator must be stable within 0.125 sec from the rising edge of the CLKEN signal.

### 3.5 Clocks

There are two clocking modes for the EP7212. Either an external clock input can be used or the on-chip PLL. The clock source is selected by a strapping option on Port E, pin 2 (PE[2]). If PE[2] is high at the rising edge of nPOR (i.e., upon power-up), the external clock mode is selected. If PE[2] is low, then the on-chip PLL mode is selected. After power-up, PE[2] can be used as a GPIO.

The EP7212 device contains several separate sections of logic, each clocked according to its own clock frequency requirements. When the EP7212 is in external clock mode, the actual frequencies at the peripherals will be different than when in PLL mode. See each peripheral device section for more details. The section below describes the clocking for both the ARM720T and address/data bus.

#### 3.5.1 On-Chip PLL

The ARM720T clock can be programmed to 18.432 MHz, 36.864 MHz, 49.152 MHz, or 73.728 MHz with the PLL running at twice the highest possible CPU clock frequency (147.456 MHz). The PLL uses an external 3.6864 MHz crystal. By chip default, the on-chip PLL is used and configured such that the ARM720T and address/data buses run at 18.432 MHz.

When the clock frequency is selected to be 36 MHz, both the ARM720T and the address/data buses are clocked at 36 MHz. When the clock frequency is selected higher than 36 MHz, only the

ARM720T gets clocked at this higher speed. The address/data will be fixed at 36 MHz. The clock frequency used is selected by programming the CLKCTL[1:0] bits in the SYSCON3 register. The clock frequency selection does not effect the EPB (external peripheral bus). Therefore, all the peripheral clocks are fixed, regardless of the clock speed selected for the ARM720T.

**NOTE:** After modifying the CLKCTL[1:0] bits, the next instruction should always be a 'NOP'.

#### 3.5.1.1 Characteristics of the PLL Interface

When connecting a crystal to the on-chip PLL interface pins (i.e. MOSCIN and MOSCOUT), the crystal and circuit should conform to the following requirements:

- The 3.6864 MHz frequency should be created by the crystals fundamental tone (i.e., it should be a fundamental mode crystal).
- A start-up resistor is not necessary, since one is provided internally.
- Start-up loading capacitors may be placed on each side of the external crystal and ground. Their value should be in the range of 10 pF. However, their values should be selected based upon the crystal specifications. The total sum of the capacitance of the traces between the EP7212's clock pins, the capacitors, and the crystal leads should be subtracted from the crystal's specifications when determining the values for the loading capacitors.
- The crystal should have a maximum 100 ppm frequency drift over the chip's operating temperature range.

Alternatively, a digital clock source can be used to drive the MOSCIN pin of the EP7212. With this approach, the voltage levels of the clock source should match that of the  $V_{DD}$  supply for the EP7212's pads (i.e. the supply voltage level used to drive all of the non- $V_{DD}$  core pins on the EP7212).

The output clock pin (i.e., MOSCOUT) should be left floating.

### 3.5.2 External Clock Input (13 MHz)

An external 13 MHz crystal oscillator can be used to drive all of the EP7212. When selected the ARM720T and the address/data buses both get clocked at 13 MHz. The fixed clock sources to the various peripherals will have different frequencies than in the PLL mode. In this configuration, the PLL will not be used at all.

**NOTE:** When operating at 13 MHz, the CLKCTL[1:0] bits should not be changed from their default value of '00'.

### 3.5.3 Dynamic Clock Switching When in the PLL Clocking Mode

The clock frequency used for the CPU and the buses is controlled by programming the CLKCTL[1:0] bits in the SYSCON3 register. When this occurs, the state controller switches from the current to the new clock frequency as soon as possible without causing a glitch on the clock signals. The glitch-free clock switching logic waits until the clock that is currently in use and the newly programmed clock source are both low, and then switches from the previous clock to the new clock without a glitch on the clocks.

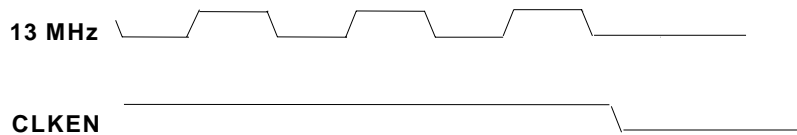

Figure 4. CLKEN Timing Entering the Standby State

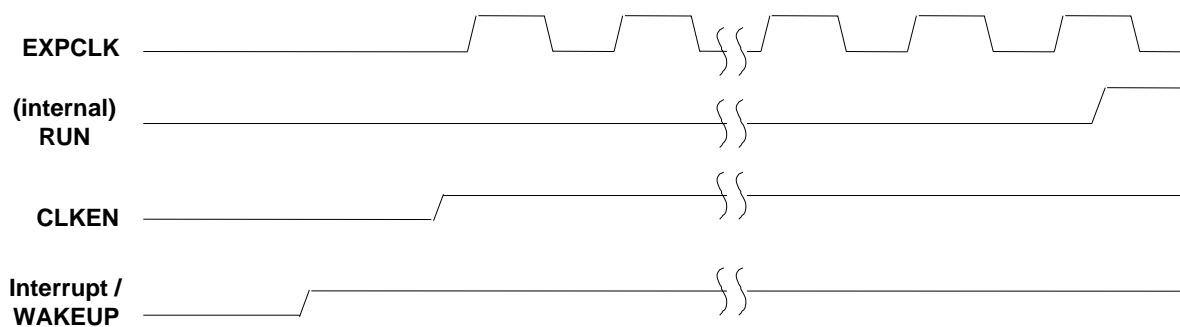

Figure 5. CLKEN Timing Entering the Standby State

### 3.6 Interrupt Controller

When unexpected events arise during the execution of a program (i.e., interrupt or memory fault) an exception is usually generated. When these exceptions occur at the same time, a fixed priority system determines the order in which they are handled. [Table 8](#) shows the priority order of all the exceptions.

Priority	Exception
Highest	Reset
.	Data Abort
.	FIQ
.	IRQ
.	Prefetch Abort
Lowest	Undefined Instruction, Software Interrupt

**Table 8. Exception Priority Handling**

The EP7212 interrupt controller has two interrupt types: interrupt request (IRQ) and fast interrupt request (FIQ). The interrupt controller has the ability to control interrupts from 22 different FIQ and IRQ sources. Of these, seventeen are mapped to the IRQ input and five sources are mapped to the FIQ input. FIQs have a higher priority than IRQs. If two interrupts are received from within the same group (IRQ or FIQ), the order in which they are serviced must be resolved in software. The priorities are listed in [Table 9](#). All interrupts are level sensitive; that is, they must conform to the following sequence.

- 1) The interrupting device (either external or internal) asserts the appropriate interrupt.
- 2) If the appropriate bit is set in the interrupt mask register, then either a FIQ or an IRQ will be asserted by the interrupt controller. (A description for each bit in this register can be found in *INTSR1 Interrupt Status Register 1*).
- 3) If interrupts are enabled the processor will jump to the appropriate address.
- 4) Interrupt dispatch software reads the interrupt

status register to establish the source(s) of the interrupt and calls the appropriate interrupt service routine(s).

- 5) Software in the interrupt service routine will clear the interrupt source by some action specific to the device requesting the interrupt (i.e., reading the UART RX register).

The interrupt service routine may then re-enable interrupts, and any other pending interrupts will be serviced in a similar way. Alternately, it may return to the interrupt dispatch code, which can check for any more pending interrupts and dispatch them accordingly. The “End of Interrupt” type interrupts are latched. All other interrupt sources (i.e., external interrupt source) must be held active until its respective service routine starts executing. See [“End Of Interrupt Locations” on page 83](#) for more details.

[Table 9](#), [Table 10](#), and [Table 11](#) show the names and allocation of interrupts in the EP7212.

#### 3.6.1 Interrupt Latencies in Different States

##### 3.6.1.1 Operating State

The ARM720T processor checks for a low level on its FIQ and IRQ inputs at the end of each instruction. The interrupt latency is therefore directly related to the amount of time it takes to complete execution of the current instruction when the interrupt condition is detected. First, there is a one to two clock cycle synchronization penalty. For the case where the EP7212 is operating at 13 MHz with a 16-bit external memory system, and instruction sequence stored in one wait state FLASH memory, the worst-case interrupt latency is 251 clock cycles. This includes a delay for cache line fills for instruction prefetches, and a data abort occurring at the end of the LDM instruction, and the LDM being non-quad word aligned. In addition, the worst-case interrupt latency assumes that LCD DMA cycles to support a panel size of 320 x

Interrupt	Bit in INTMR1 and INTSR1	Name	Comment
FIQ	0	EXTFIQ	External fast interrupt input (nEXTFIQ pin)
FIQ	1	BLINT	Battery low interrupt
FIQ	2	WEINT	Tick Watchdog expired interrupt
FIQ	3	MCINT	Media changed interrupt
IRQ	4	CSINT	Codec sound interrupt
IRQ	5	EINT1	External interrupt input 1 (nEINT[1] pin)
IRQ	6	EINT2	External interrupt input 2 (nEINT[2] pin)
IRQ	7	EINT3	External interrupt input 3 (EINT[3] pin)
IRQ	8	TC1OI	TC1 underflow interrupt
IRQ	9	TC2OI	TC2 underflow interrupt
IRQ	10	RTCMI	RTC compare match interrupt
IRQ	11	TINT	64 Hz tick interrupt
IRQ	12	UTXINT1	Internal UART1 transmit FIFO empty interrupt
IRQ	13	URXINT1	Internal UART1 receive FIFO full interrupt
IRQ	14	UMSINT	Internal UART1 modem status changed interrupt
IRQ	15	SSEOTI	Synchronous serial interface 1 end of transfer interrupt

**Table 9. Interrupt Allocation in the First Interrupt Register**

Interrupt	Bit in INTMR2 and INTSR2	Name	Comment
IRQ	0	KBDINT	Key press interrupt
IRQ	1	SS2RX	Master / slave SSI 16 bytes received
IRQ	2	SS2TX	Master / slave SSI 16 bytes transmitted
IRQ	12	UTXINT2	UART2 transmit FIFO empty interrupt
IRQ	13	URXINT2	UART2 receive FIFO full interrupt

**Table 10. Interrupt Allocation in the Second Interrupt Register**

Interrupt	Bit in INTMR3 and INTSR3	Name	Comment
FIQ	0	DAIINT	DAI interface interrupt

**Table 11. Interrupt Allocation in the Third Interrupt Register**

240 at 4 bits-per-pixel, 60 Hz refresh rate, is in progress.

This would give a worst-case interrupt latency of about 19.3  $\mu$ s for the ARM720T processor operating at 13 MHz in this system. For those interrupt inputs which have de-glitching, this figure is increased by the maximum time required to pass through the deglitcher, which is approximately 125  $\mu$ s (2 cycle of the 16.384 kHz clock derived from the RTC oscillator). This would create an absolute worst-case latency of approximately 141  $\mu$ s. If the ARM720T is run at 36 MHz or greater and/or 32 bit wide external memory, the 19.3  $\mu$ s value will be reduced.

All the serial data transfer peripherals included in the EP7212 (except for the master-only SSI1) have local buffering to ensure a reasonable interrupt latency response requirement for the OS of 1 ms or less. This assumes that the design data rates do not exceed the data rates described in this specification. If the OS cannot meet this requirement, there will be a risk of data over/underflow occurring.

### 3.6.1.2 Idle State

When leaving the Idle State as a result of an interrupt, the CPU clock is restarted after approximately two clock cycles. However, there is still potentially up to 20  $\mu$ sec latency as described in the first section above, unless the code is written to include at least two single cycle instructions immediately after the write to the IDLE register (in which case the latency drops to a few microseconds). This is important, as the Idle State can only be left because of a pending interrupt, which has to be synchronized by the processor before it can be serviced.

### 3.6.1.3 Standby State

In the Standby State, the latency will depend on whether the system clock is shut down and if the FASTWAKE bit in the SYSCON3 register is set. If the system is configured to run from the internal PLL clock, then the PLL will always be shut down

when in the Standby State. In this case, if the FASTWAKE bit is cleared, then there will be a latency of between 0.125 sec to 0.25 sec. If the FASTWAKE bit is set, then there will be a latency of between 250  $\mu$ sec to 500  $\mu$ sec. If the system is running from the external clock (at 13 MHz), with the CLKENSL bit in SYSCON2 set to 0, then the latency will also be between 0.125 sec and 0.25 sec to allow an external oscillator to stabilize. In the case of a 13 MHz system where the clock is not disabled during the Standby State (CLKENSL = 1), then the latency will be the same as described in the Idle State section above.

Whenever the EP7212 is in the Standby State, the external address and data buses are driven low. The RUN signal is used internally to force these buses to be driven low. This is done to prevent peripherals that are power-down from draining current. Also, the internal peripheral's signals get set to their Reset State.

[Table 12](#) summarizes the five external interrupt sources and the effect they have on the processor interrupts.

## 3.7 EP7212 Boot ROM

The 128 bytes of on-chip Boot ROM contain an instruction sequence that initializes the device and then configures UART1 to receive 2048 bytes of serial data that will then be placed in the on-chip SRAM. Once the download is complete, execution jumps to the start of the on-chip SRAM. This would allow, for example, code to be downloaded to program system FLASH during a product's manufacturing process. See *Appendix A: Boot Code* for details of the ROM Boot Code with comments to describe the stages of execution.

Selection of the Boot ROM option is determined by the state of the nMEDCHG pin during a power on reset. If nMEDCHG is high while nPOR is active, then the EP7212 will boot from an external memory device connected to CS[0] (normal boot mode).

Interrupt Pin	Input State	Operating State Latency	Idle State Latency	Standby State Latency
nEXTFIQ	Not deglitched; must be active for 20 $\mu$ s to be detected	Worst-case latency of 20 $\mu$ sec	Worst-case 20 $\mu$ sec: if only single cycle instructions, less than 1 $\mu$ sec	Including PLL / osc. settling time, approx. 0.25 sec when FASTWAKE = 0, or approx. 500 $\mu$ sec when FASTWAKE = 1, or = Idle State if in 13 MHz mode with CLKENSL set
nEINT1–2	Not deglitched	Worst-case latency of 20 $\mu$ sec	As above	As above
EINT3	Not deglitched	Worst-case latency of 20 $\mu$ sec	As above	As above
nMEDCHG	Deglitched by 16 kHz clock; must be active for at least 125 $\mu$ s to be detected	Worst-case latency of 141 $\mu$ sec	Worst-case 80 $\mu$ sec: if only single cycle instructions, 125 $\mu$ sec	As above (note difference if in 13 MHz mode with CLKENSL set)

**Table 12. External Interrupt Source Latencies**

If nMEDCHG is low, then the boot will be from the on-chip ROM. Note that in both cases, following the de-assertion of power on reset, the EP7212 will be in the Standby State and requires a low-to-high transition on the external WAKEUP pin in order to actually start the boot sequence.

The effect of booting from the on-chip Boot ROM is to reverse the decoding for all chip selects internally. Table 13 shows this decoding. The control signal for the boot option is latched by nPOR, which means that the remapping of addresses and bus widths will continue to apply until nPOR is asserted again. After booting from the Boot ROM, the contents of the Boot ROM can be read back from address 0x00000000 onwards, and in normal state of operation the Boot ROM contents can be read back from address range 0x70000000.

### 3.8 Memory and I/O Expansion Interface

Six separate linear memory or expansion segments are decoded by the EP7212, two of which can be reserved for two PC Card cards, each interfacing to a separate single CL-PS6700 device. Each segment is 256 Mbytes in size. Two additional segments (i.e., in addition to these six) are dedicated to the on-chip SRAM and the on-chip ROM. The on-chip ROM space is fully decoded, and the SRAM space

Address Range	Chip Select
0000.0000–0FFF.FFFF	CS[7] (Internal only)
1000.0000–1FFF.FFFF	CS[6] (Internal only)
2000.0000–2FFF.FFFF	nCS[5]
3000.0000–3FFF.FFFF	nCS[4]
4000.0000–4FFF.FFFF	nCS[3]
5000.0000–5FFF.FFFF	nCS[2]
6000.0000–6FFF.FFFF	nCS[1]
7000.0000–7FFF.FFFF	nCS[0]

**Table 13. Chip Select Address Ranges After Boot From On-Chip Boot ROM**

is fully decoded up to the maximum size of the video frame buffer programmed in the LCDCON register (128 kbytes). Beyond this address range the SRAM space is not fully decoded (i.e., any accesses beyond 128 kbyte range get wrapped around to within 128 kbyte range). Any of the six segments are configured to interface to a conventional SRAM-like interface, and can be individually programmed to be 8-, 16-, or 32-bits wide, to support page mode access, and to execute from 1 to 8 wait states for non-sequential accesses and 0 to 3 for burst mode accesses. The zero wait state sequential access feature is designed to support burst mode

ROMs. For writable memory devices which use the nMWE pin, zero wait state sequential accesses are not permitted and one wait state is the minimum which should be programmed in the sequential field of the appropriate MEMCFG register. Bus cycles can also be extended using the EXPRDY input signal.

Page mode access is accomplished by setting SQAEN = 1, which enables accesses of the form one random address followed by three sequential addresses, etc., while keeping nCS asserted. These sequential bursts can be up to four words long before nCS is released to allow DMA and refreshes to take place. This can significantly improve bus bandwidth to devices such as ROMs which support page mode. When SQAEN = 0, all accesses to memory are by random access without nCS being de-asserted between accesses. Again nCS is de-asserted after four consecutive accesses to allow DMAS.

Bits 5 and 6 of the SYSCON2 register independently enable the interfaces to the CL-PS6700 (PC Card slot drivers). When either of these interfaces are enabled, the corresponding chip select (nCS4 and/or nCS5) becomes dedicated to that CL-PS6700 interface. The state of SYSCON2 bit 5 determines the function of chip select nCS4 (i.e., CL-PS6700 interface or standard chip select functionality); bit 6 controls nCS5 in a similar way. There is no interaction between these bits.

For applications that require a display buffer smaller than 38,400 bytes, the on-chip SRAM can be used as the frame buffer.

The width of the boot device can be chosen by selecting values of PE[1] and PE[0] during power on reset. The inputs in Table 14 are latched by the rising edge of nPOR to select the boot option.

### 3.9 DRAM Controller with EDO Support

The DRAM controller in the EP7212 provides all the connections to directly interface to up to two

PE[1]	PE[0]	Boot Block (nCS0)
0	0	32-bit
0	1	8-bit
1	0	16-bit
1	1	Undefined

**Table 14. Boot Options**

banks of (EDO) DRAM, and the width of the memory interface is programmable to 16-bits or 32-bits. **Both banks have to be of the same width.** The 16/32-bit DRAM width selection is made based on bit 2 of the SYSCON2 register. Each of the two banks supported can be up to 256 Mbytes in size. Two RAS lines and four CAS lines are provided, with one CAS line per byte lane. The DRAM controller does not support device size programmability. Therefore, if two banks are implemented and DRAM devices are used, a bank smaller than 256 Mbytes would be created leading to a segmented memory map. Each segmented bank will be separated by 256 Mbytes. Segments that are smaller than the bank size will repeat within the bank. Table 15. Physical to DRAM Address Mapping shows the mapping of the physical address to DRAM row and column addresses. This mapping has been organized to support any DRAM device size from 4 Mbits to 1 Gbits with a square row and column configuration (i.e., the number of column addresses is equal to the number of row addresses). If a non-square DRAM is used, further fragmentation of the memory map will occur, however the smallest contiguous segment will always be 1 Mbyte. With proper mapping of pages/sections by the MMU, one can create contiguous memory blocks.

On boot-up, the DRAM controller is configured for operation with an 18.432 MHz internal bus speed, and therefore, can support either fast page mode or EDO DRAM. In this case, the read data from the DRAM is latched within the EP7212 on the rising edge of the nCAS output strobes. The DRAM must

not have an access time greater than 70 ns in order to meet the 18 MHz timing requirements. When the internal bus is operating at 36.864 MHz (i.e., for CPU clock frequencies of 36.864, 49.152, or 73.728 MHz), the DRAM controller will only operate with EDO DRAM. When operating at 36 MHz, the EDO DRAM must not have an access time greater than 50 ns. The DRAM cycle timings are adjusted to take advantage of the additional performance available from fast EDO DRAM. In EDO mode, the EP7212 design relies on the DRAM data being driven to be available on the external data bus during the entire high phase of the nCAS signal so that it can be latched towards the end of the cycle. In Fast Page mode, the data should be latched at the rising edge of nCAS. It is not possible to use

the EP7212 with fast page mode DRAM at operating frequencies of 36 MHz or higher.

The DRAM controller breaks all sequential access, so that the minimum page sizes defined can be supported. All of the possible page sizes are multiples of the minimum page size, so by breaking up accesses on minimum page sizes by default, all accesses crossing larger page boundaries are broken up.

**Table 16 DRAM Address Mapping for a 32-Bit DRAM Memory System** shows the address mapping for various DRAM's with square and non-square row and address inputs. This assumes two x16 devices are connected to each RAS line with 32-bit wide DRAM operation selected. This mapping is then repeated every 256 Mbytes for each

DRAM Address Pins	DRAM Column x16 Mode	DRAM Column x32 Mode	DRAM Row x16 Mode	DRAM Row x32 Mode	7212 Pin Name
0	A1 <sup>1</sup>	A2	A9	A10	A[27]/DRA[0]
1	A2	A3	A10	A11	A[26]/DRA[1]
2	A3	A4	A11	A12	A[25]/DRA[2]
3	A4	A5	A12	A13	A[24]/DRA[3]
4	A5	A6	A13	A14	A[23]/DRA[4]
5	A6	A7	A14	A15	A[22]/DRA[5]
6	A7	A8	A15	A16	A[21]/DRA[6]
7	A8	A9	A16	A17	A[20]/DRA[7]
8	A18	A19	A17	A18	A[19]/DRA[8]
9	A20	A21	A19	A20	A[18]/DRA[9]
10	A22	A23	A21	A22	A[17]/DRA[10]
11	A24	A25	A23	A24	A[16]/DRA[11]
12	A26	A27	A25	A26	A[15]/DRA[12]

**Table 15. Physical to DRAM Address Mapping**

1. This bit will be generated by the DRAM controller.

An example of the DRAM connections for a typical system can be found in **Figure 12. A Maximum EP7212 Based System** on page 52.



A complete description of the protocol and AC timing characteristics can be found in the CL-PS6700 data sheet. A transaction is initiated by an access to the nCS4 or nCS5 area. The chip select is asserted, and on the first clock, the upper 10 bits of the PC Card address, along with 6 bits of size, space, and slot information are put out onto the lower 16 bits of the EP7212's data bus. Only word (i.e., 4-byte) and single-byte accesses are supported, and the slot field is hardcoded to 11, since the slot field is defined as a 'Reserved field' by the CL-PS6700. The chip selects are used to select the device to be accessed. The space field is made directly from the A26 and A27 CPU address bits, according to the decode shown in [Table 18](#). The size field is forced to 11 if a word access is required, or to 00 if a byte access is required. This avoids the need to configure the interface after a reset. On the second clock cycle, the remaining 16 bits of the PC Card address are multiplexed out onto the lower 16 bits of the data bus. If the transaction selected is a CL-PS6700 register transaction, or a write to the PC Card (as-

suming there is space available in the CL-PS6700's internal write buffer) then the access will continue on the following two clock cycles. During these following two clock cycles the upper and lower halves of the word to be read or written will be put onto the lower 16 bits of the main data bus.

The 'ptype' signal on the CL-PS6700s should be connected to the EP7212's WRITE output pin. During PC Card accesses, the polarity of this pin changes, and it becomes low to signify a write and high to signify a read. It is valid with the first half word of the address. During the second half word of the address, it is always forced high to indicate to the CL-PS6700 that the EP7212 has initiated either the write or read.

The PRDY signals from each of the two CL-PS6700 devices are connected to Port B bits 0 and 1, respectively. When the PC CARD1 or PC CARD2 control bits in the SYSCON2 register are de-asserted, these port bits are available for GPIO. When asserted, these port bits are used as the

Access Type	Addresses for CL-PS6700 Interface 1	Addresses for CL-PS6700 Interface 2
Attribute	0x40000000–0x43FFFFFF	0x50000000– 0x53FFFFFF
I/O	0x44000000–0x47FFFFFF	0x54000000–0x57FFFFFF
Common memory	0x48000000–0x4BFFFFFF	0x58000000–0x5BFFFFFF
CL-PS6700 registers	0x4C000000–0x4FFFFFFF	0x5C000000–0x5FFFFFFF

**Table 17. CL-PS6700 Memory Map**

Space Field Value	PC CARD Memory Space
00	Attribute
01	I/O
10	Common memory
11	CL-PS6700 registers

**Table 18. Space Field Decoding**

PRDY signals. When the PRDY signal is de-asserted (i.e., low), it indicates that the CL-PS6700 is busy accessing its card. If a PC CARD access is attempted while the device is busy, the PRDY signal will cause the EP7212's CPU to be stalled. The EP7212's CPU will have to wait for the card to become available. DMA transfers to the LCD can still continue in the background during this period of time (as described below). The EP7212 can access the registers in the CL-PS6700, regardless of the state of the PRDY signal. If the EP7212 needs to access the PC CARD via the CL-PS6700, it waits until the PRDY signal is high before initiating a transfer request. Once a request is sent, the PRDY signal indicates if data is available.

In the case of a PC Card write, writes can be posted to the CL-PS6700 device, with the same timing as CL-PS6700 internal register writes. Writes will normally be completed by the CL-PS6700 device independent of the EP7212 processor activity. If a posted write times out, or fails to complete for any other reason, then the CL-PS6700 will issue an interrupt (i.e., a WR\_FAIL interrupt). In the case where the CL-PS6700 write buffer is already full, the PRDY signal will be de-asserted (i.e., driven low) and the transaction will be stalled pending an available slot in the buffer. In this case, the EP7212's CPU will be stalled until the write can be posted successfully. While the PRDY signal is de-asserted, the chip select to the CL-PS6700 will be de-asserted and the main bus will be released so that DMA transfers to the LCD controller can continue in the background.

In the case of a PC Card read, the PRDY signal from the CL-PS6700 will be de-asserted until the read data is ready. At this point, it will be reasserted and the access will be completed in the same way as for a register access. In the case of a byte access, only one 16-bit data transfer will be required to complete the access. While the PRDY signal is de-asserted, the chip select to the CL-PS6700 will be de-asserted, and the main bus will be released so

that DMA transfers to the LCD controller can continue in the background.

The EP7212 will re-arbitrate for control of the bus when the PRDY signal is reasserted to indicate that the read or write transaction can be completed. The CPU will always be stalled until the PC Card access is completed.

A card read operation may be split into a request cycle and a data cycle, or it may be combined into a single request/data transfer cycle. This depends on whether the data requested from the card is available in the prefetch buffer (internal to the CL-PS6700).

The request portion of the cycle, for a card read, is similar to the request phase for a card write (described above). If the requested data is available in the prefetch buffer, the CL-PS6700 asserts the PRDY signal before the rising edge of the third clock and the EP7212 continues the cycle to read the data. Otherwise, the PRDY signal is de-asserted, and the request cycle is stalled. The EP7212 may then allow the DMA address generator to gain control of the bus, to allow LCD refreshes to continue. When the CL-PS6700 is ready with the data, it asserts the PRDY signal. The EP7212 then arbitrates for the bus and, once the request is granted, the suspended read cycle is resumed. The EP7212 resumes the cycle by asserting the appropriate chip select, and data is transferred on the next two clocks if a word read (one clock if a byte read).

There is no support within the EP7212 for detecting time-outs. The CL-PS6700 device must be programmed to force the cycle to be completed (with invalid data for a read) and then generate an interrupt if a read or write access has timed out (i.e., RD\_FAIL or WR\_FAIL interrupt). The system software can then determine which access was not successfully completed by reading the status registers within the CL-PS6700.

The CL-PS6700 has support for DMA data transfers. However, DMA is supported only by software

emulation because the DMA address generator built into the EP7212 is dedicated to the LCD controller interface. If DMA is enabled within the CL-PS6700, it will assert its PDREQ signal to make a DMA request. This can be connected to one of the EP7212's external interrupts and be used to interrupt the CPU so that the software can service the DMA request under program control.

Each of the CL-PS6700 devices can generate an interrupt PIRQ. Since the PIRQ signal is an open drain on the CL-PS6700 devices, two CL-PS6700 devices may be wired OR'ed to the same interrupt. The circuit can then be connected to one of the EP7212's active low external interrupt sources. On the receipt of an interrupt, the CPU can read the interrupt status registers on the CL-PS6700 devices to determine the cause of the interrupt.

All transactions are synchronized to the EXPCLK output from the EP7212 in 18.432 MHz mode or the external 13 MHz clock. The EXPCLK should be permanently enabled, by setting the EXCKEN bit in the SYSCON1 register, when the CL-PS6700 is used. The reason for this is that the PC Card interface and CL-PS6700 internal write buffers need to be clocked after the EP7212 has completed its bus cycles.

A GPIO signal from the EP7212 can be connected to the PSLEEP pin of the CL-PS6700 devices to allow them to be put into a power saving state before the EP7212 enters the Standby State. It is essential that the software monitor the appropriate status registers within the CL-PS6700s to ensure that there are no pending posted bus transactions before the Standby State is entered. Failure to do this will result in incomplete PC Card accesses.

### 3.11 Endianness

The EP7212 uses a little endian configuration for internal registers. However, it is possible to connect the device to a big endian external memory system. The big-endian / little-endian bit in the

ARM720T control register sets whether the EP7212 treats words in memory as being stored in big endian or little endian format. Memory is viewed as a linear collection of bytes numbered upwards from zero. Bytes 0 to 3 hold the first stored word, bytes 4 to 7 the second, and so on. In the little endian scheme, the lowest numbered byte in a word is considered to be the least significant byte of the word and the highest numbered byte is the most significant. Byte 0 of the memory system should be connected to data lines 7 through 0 (D[7:0]) in this scheme. In the big endian scheme the most significant byte of a word is stored at the lowest numbered byte, and the least significant byte is stored at the highest numbered byte. Therefore, byte 0 of the memory system should be connected to data lines 31 through 24 (D[31:24]). Load and store are the only instructions affected by the Endianness.

Tables 19 and 20 demonstrate the behavior of the EP7212 in big and little endian mode, including the effect of performing non-aligned word accesses. The register definition section of this specification defines the behavior of the internal EP7212 registers in the big endian mode in more detail. For further information, refer to *ARM Application Note 61, Big and Little Endian Byte Addressing*.

### 3.12 Internal UARTs (Two) and SIR Encoder

The EP7212 contains two built-in UARTs that offers similar functionality to National Semiconductor's 16C550A device. Both UARTs can support bit rates of up to 115.2 kbits/s and include two 16-byte FIFOs: one for receive and one for transmit.

One of the UARTs (UART1) supports the three modem control input signals CTS, DSR, and DCD. The additional RI input, and RTS and DTR output modem control lines are not explicitly supported but can be implemented using GPIO ports in the EP7212. UART2 has only the RX and TX pins.

Address (W/B)	Data in Memory (as seen by the EP7212)	Byte Lanes to Memory / Ports / Registers								R0 Contents	
		Big Endian Memory				Little Endian Memory				Big Endian	Little Endian
		7:0	15:8	23:16	31:24	7:0	15:8	23: 16	31: 24		
Word + 0 (W)	11223344	44	33	22	11	44	33	22	11	11223344	11223344
Word + 1 (W)	11223344	44	33	22	11	44	33	22	11	44112233	44112233
Word + 2 (W)	11223344	44	33	22	11	44	33	22	11	33441122	33441122
Word + 3 (W)	11223344	44	33	22	11	44	33	22	11	22334411	22334411
Word + 0 (H)	11223344	44	33	22	11	44	33	22	11	00001122	00003344
Word + 1 (H)	11223344	44	33	22	11	44	33	22	11	22000011	44000033
Word + 2 (H)	11223344	44	33	22	11	44	33	22	11	00003344	00001122
Word + 3 (H)	11223344	44	33	22	11	44	33	22	11	44000033	22000011
Word + 0 (B)	11223344	dc	dc	dc	11	44	dc	dc	dc	00000011	00000044
Word + 1 (B)	11223344	dc	dc	22	dc	dc	33	dc	dc	00000022	00000033
Word + 2 (B)	11223344	dc	33	dc	dc	dc	dc	22	dc	00000033	00000022
Word + 3 (B)	11223344	44	dc	dc	dc	dc	dc	dc	11	00000044	00000011

**NOTE:** dc = don't care

**Table 19. Effect of Endianness on Read Operations**

Address (W/B)	Register Contents	Byte Lanes to Memory / Ports / Registers							
		Big Endian Memory				Little Endian Memory			
		7:0	15:8	23:16	31:24	7:0	15:8	23:16	31:24
Word + 0 (W)	11223344	<b>44</b>	<b>33</b>	<b>22</b>	<b>11</b>	<b>44</b>	<b>33</b>	<b>22</b>	<b>11</b>
Word + 1 (W)	11223344	<b>44</b>	<b>33</b>	<b>22</b>	<b>11</b>	<b>44</b>	<b>33</b>	<b>22</b>	<b>11</b>
Word + 2 (W)	11223344	<b>44</b>	<b>33</b>	<b>22</b>	<b>11</b>	<b>44</b>	<b>33</b>	<b>22</b>	<b>11</b>
Word + 3 (W)	11223344	<b>44</b>	<b>33</b>	<b>22</b>	<b>11</b>	<b>44</b>	<b>33</b>	<b>22</b>	<b>11</b>
Word + 0 (H)	11223344	44	33	<b>44</b>	<b>33</b>	<b>44</b>	<b>33</b>	44	33
Word + 1 (H)	11223344	44	33	<b>44</b>	<b>33</b>	<b>44</b>	<b>33</b>	44	33
Word + 2 (H)	11223344	<b>44</b>	<b>33</b>	44	33	44	33	<b>44</b>	<b>33</b>
Word + 3 (H)	11223344	<b>44</b>	<b>33</b>	44	33	44	33	<b>44</b>	<b>33</b>
Word + 0 (B)	11223344	44	44	44	<b>44</b>	<b>44</b>	44	44	44
Word + 1 (B)	11223344	44	44	<b>44</b>	44	44	<b>44</b>	44	44
Word + 2 (B)	11223344	44	<b>44</b>	44	44	44	44	<b>44</b>	44
Word + 3 (B)	11223344	<b>44</b>	44	44	44	44	44	44	<b>44</b>

**NOTE:** Bold indicates active byte lane.

**Table 20. Effect of Endianness on Write Operations**

UART operation and line speeds are controlled by the UBLCR1 (UART bit rate and line control). Three interrupts can be generated by UART1: RX, TX, and modem status interrupts. Only two can be generated by UART2: RX and TX. The RX interrupt is asserted when the RX FIFO becomes half full or if the FIFO is non-empty for longer than three character length times with no more characters being received. The TX interrupt is asserted if the TX FIFO buffer reaches half empty. The modem status interrupt for UART1 is generated if any of the modem status bits change state. Framing and parity errors are detected as each byte is received and pushed onto the RX FIFO. An overrun error generates an RX interrupt immediately. All error bits can be read from the 11-bit wide data register. The FIFOs can also be programmed to be one byte depth only (i.e., like a conventional 16450 UART with double buffering).

The EP7212 also contains an IrDA (Infrared Data Association) SIR protocol encoder as a post-processing stage on the output of UART1. This encoder can be optionally switched into the TX and RX signals of UART1, so that these can be used to drive an infrared interface directly. If the SIR protocol encoder is enabled, the UART TXD1 line is held in the passive state and transitions of the RXD1 line will have no effect. The IrDA output pin is LEDDRV, and the input from the photodiode is PHDIN. Modem status lines will cause an interrupt (which can be masked) irrespective of whether the SIR interface is being used.

Both the UARTs operate in a similar manner to the industry standard 16C550A. When CTS is deasserted on the UART, the UART does not stop shifting the data. It relies on software to take appropriate action in response to the interrupt generated.

Baud rates supported for both the UARTs are dependent on frequency of operation. When operating from the internal PLL, the interface supports various baud rates from 115.2 kbits/s downwards. The master clock frequency is chosen so that most of the required data rates are obtainable exactly. When operating with a 13.0 MHz external clock source, the baud rates generated will have a slight error, which is less than or equal to 0.75%. The rates (all measured in kbits/s) obtainable from the 13 MHz clock include: 9.6, 19.2, 38, 58, and 115.2. See *UBRLCR1-2 UART1-2 Bit Rate and Line Control Registers* for full details of the available bit rates in the 13 MHz mode.

### 3.13 Serial Interfaces

In addition to the two UARTs, the EP7212 offers the following serial interfaces shown in [Table 21](#). The inputs / outputs of three of the serial interfaces (DAI, codec, and SSI2) are multiplexed onto a single set of external interface pins. If the DAISEL bit of SYSCON3 is low, then either SSI2 or the codec interface will be selected to connect to the external pins. When bit 0 of SYSCON2 (SERSEL) is high, then the codec is connected to the external pins, when low the master / slave SSI2 is connected to these pins. When the DAISEL bit is set high, the DAI interface is connected to the external pins. On power up, both the DAISEL and SERSEL bits are reset low, thus the master / slave SSI2 will be connected to these pins (and configured for slave mode operation to avoid external drive clashes).

[Table 22](#) contains pin definition information for the three multiplexed interfaces.

The internal names given to each of the three interfaces are unique to help differentiate them from each other. The sections below that describe each of the three interfaces will use their respective unique internal pin names for clarity.

### 3.13.1 Codec Sound Interface

The codec interface allows direct connection of a telephony type codec to the EP7212. It provides all the necessary clocks and timing pulses. It also performs a parallel to serial conversion or vice versa on the data stream to or from the external codec device. The interface is full duplex and contains two separate data FIFOs (16 deep by 8-bits wide, one for the receive data, another for the transmit data).

Data is transferred to or from the codec at 64 kbits/s. The data is either written to or read from the appropriate 16-byte FIFO. If enabled, a codec interrupt (CSINT) will be generated after every 8 bytes are transferred (FIFO half full/empty). This means the interrupt rate will be every 1 msec, with a latency of 1 msec.

Transmit and receive modes are enabled by asserting high both the CDENRX and CDENTX codec enable bits in the SYSCON1 register.

**NOTE:** Both the CDENRX and CDENTX enable bits should be asserted in tandem for data to be transmitted or received. The reason for this is that the interrupt generation will occur 1 msec after one of the FIFOs is enabled. For example: If the receive FIFO gets enabled first and the transmit FIFO at a later time, the interrupt will occur 1 msec after the receive FIFO is enabled. After the first interrupt occurs, the receive FIFO will be half full. However, it will not be possible to know how full the transmit FIFO will be since it was enabled at a later time. Thus, it is possible to unintentionally overwrite data already in the transmit FIFO (See [Figure 6](#)).

After the CDENRX and CDENTX enable bits get asserted, the corresponding FIFOs become enabled. When both FIFOs are disabled, the FIFO sta-

Type	Comments	Referred To As	Max. Transfer Speed
SPI / Microwire 1	Master mode only	ADC Interface	128 kbits/s
SPI / Microwire 2	Master / slave mode	SSI2 Interface	512 kbits/s
DAI Interface	CD quality DACs and ADCs	DAI Interface	1.536 Mbits/s
Codec Interface	<b>Only</b> for use in the PLL clock mode	Codec Interface	64 kbits/s

**Table 21. Serial Interface Options**

Pin No. LQFP	External Pin Name	SSI2 Slave Mode (Internal Name)	SSI2 Master Mode	Codec Internal Name	DAI Internal Name	Strength
63	SSICLK	SSICLK = serial bit clock; Input	Output	PCMCLK = Output	SCLK = Output	1
65	SSITXFR	SSITXFR = TX frame sync; Input	Output	PCMSYNC = Output	LRCK = Output	1
66	SSITXDA	SSITXDA = TX data; Output	Output	PCMOUT = Output	SDOUT = Output	1
67	SSIRXDA	SSIRXDA = RX data; Input	Input	PCMIN = Input	SDIN = Input	
68	SSIRXFR	SSIRXFR = RX frame sync; Input	Output	p/u (use a 10k pull-up)	MCLK	1

**Table 22. Serial-Pin Assignments**

tus flag CRXFE is set and CTXFF is cleared so that the FIFOs appear empty. Additionally, if the CDENTX bit is low, the PCMOUT output is disabled. Asserting either of the two enable bits causes the sync and interrupt generation logic to become active; otherwise they are disabled to conserve power.

Data is loaded into the transmit FIFO by writing to the CODR register. At the beginning of a transmit cycle, this data is loaded into a shift/load register. Just prior to the byte being transferred out, PCMSYNC goes high for one PCMCLK cycle. Then the data is shifted out serially to PCMOUT, MSB first, (with the MSB valid at the same time PCMSYNC is asserted). Data is shifted on the rising edge of the PCMCLK output.

Receiving of data is performed by taking data in serially through PCMIN, again MSB first, shifting it through the shift/load register and loading the complete byte into the receive FIFO. If there is no data

available in the transmit FIFO, then a zero will be loaded into the shift/load register. Input data is sampled on the falling edge of PCMCLK. Data is read from the CODR register.

### 3.13.2 Digital Audio Interface

The DAI interface provides a high quality digital audio connection to DAI compatible audio devices. The DAI is a subset of I2S audio format that is supported by a number of manufacturers.

The DAI interface produces one 128-bit frame at the audio sample frequency using a bit clock and frame sync signal. Digital audio data is transferred, full duplex, via separate transmit and receive data lines. The bit clock frequency is either fixed at 9.216 MHz or set via an externally supplied MCLK signal.

The DAI interface contains separate transmit and receive FIFO's. The transmit FIFO's are 8 audio

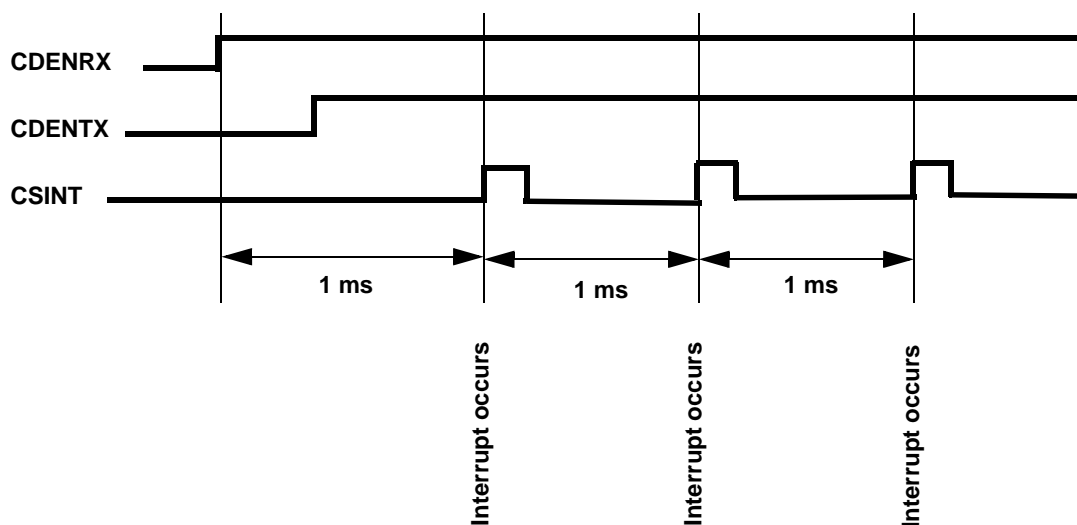

Figure 6. Codec Interrupt Timing

samples deep and the receive FIFO's are 12 audio samples deep.

### 3.13.2.1 DAI Operation

Following reset, the DAI logic is disabled. To enable the DAI, the applications program should first clear the emergency underflow and overflow status bits, which are set following the reset, by writing a 1 to these register bits (in the DAISR register). Next, the DAI control register should be programmed with the desired mode of operation using a word write. The transmit FIFOs can either be "primed" by writing up to eight 16-bit values each, or can be filled by the normal interrupt service routine which handles the DAI FIFOs. Finally, the FIFOs for each channel must be enabled via writes

to DAIDR2. At this point, transmission/reception of data begins on the transmit (SDOUT) and receive (SDIN) pins. This is synchronously controlled by the 9.216 MHz (6.5 MHz in 13 MHz mode) internal clock or the externally supplied bit clock (SCLK), and the serial frame clock (LRCK).

### 3.13.2.2 DAI Frame Format

Each DAI frame is 128 bits long and it comprises one audio sample. Of this 128-bit frame, only 32 bits are actually used for digital audio data. The remaining bits are output as zeros. The LRCK signal is used as a frame synchronization signal. Each transition of LRCK delineates the left and right halves of an audio sample. When LRCK transitions from high to low the next 16-bits make up the left

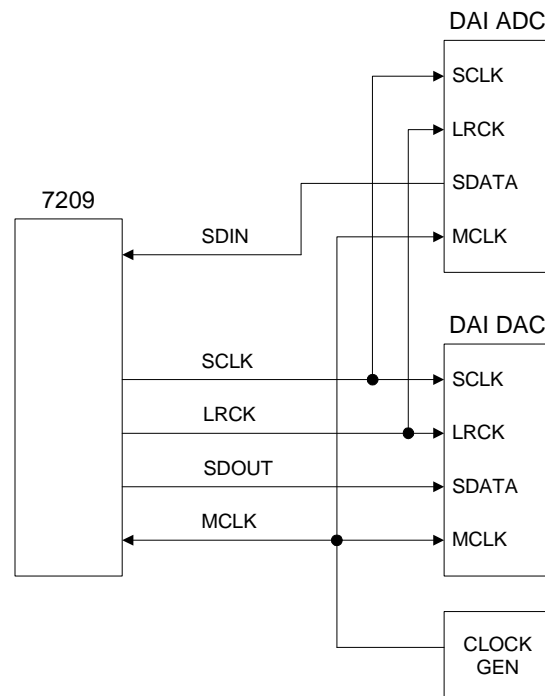

**Figure 7. DAI Interface**

side of an audio sample. When LRCK transitions from low to high the next 16-bits make up the right side of an audio sample.

### 3.13.2.3 DAI Signals

- MCLK**    oversampled clock. Used as an input to the EP7212 for generating the DAI timing. This signal is also usually used as an input to a DAC/ADC as an oversampled clock. This signal is fixed at 256 times the audio sample frequency.
- SCLK**    bit clock. Used as the bit clock input into the DAC/ADC. This signal is fixed at 128 times the audio sample frequency.
- LRCK**    Frame sync. Used as a frame synchronization input to the DAC/ADC. This signal is fixed at the audio sample frequency. This signal is clocked out on the negative going edge of SCLK.
- SDOUT**    Digital audio data out. Used for sending playback data to a DAC. This signal is clocked out on the negative going edge of the SCLK output.

- SDIN**    Digital audio input. Used for receiving record data from an ADC. This signal is latched by the EP7212 on the positive going edge of SCLK.

### 3.13.3 ADC Interface — Master Mode Only SSII (Synchronous Serial Interface)

The first synchronous serial interface allows interfacing to the following peripheral devices:

- In the default mode, the device is compatible with the MAXIM MAX148/9 in external clock mode. Similar SPI- or Microwire-compatible devices can be connected directly to the EP7212.
- In the extended mode and with negative-edge triggering selected (the ADCCON and ADCCKNSEN bits are set, respectively, in the SYSCON3 register), this device can be interfaced to Analog Devices' AD7811/12 chip using nADCCS as a common RFS/TFS line.
- Other features of the devices, including power management, can be utilized by software and the use of the GPIO pins.

The clock output frequency is programmable and only active during data transmissions to save power. There are four output frequencies selectable, which will be slightly different depending whether

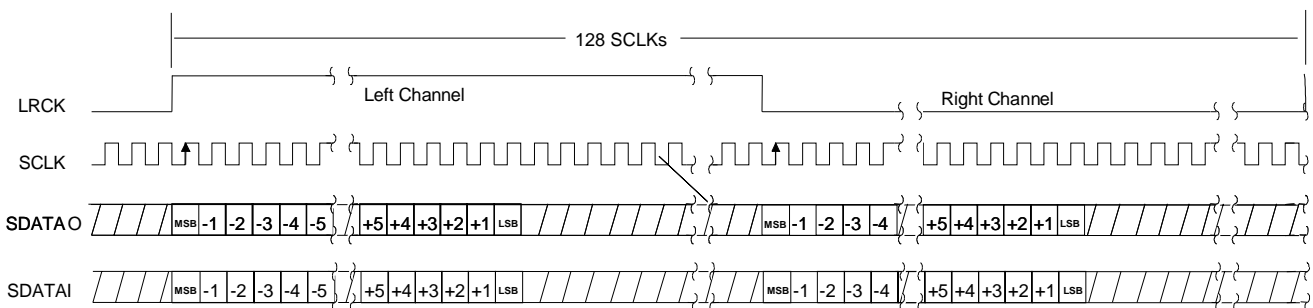

**Figure 8. EP7212 Rev C - Digital Audio Interface Timing – MSB / Left Justified format**

the device is operating in a 13 MHz mode or a 18.432 MHz–73.728 MHz mode (see [Table 23](#)). The required frequency is selected by programming the corresponding bits 16 and 17 in the SYSCON1 register. The sample clock (SMPCLK) always runs at twice the frequency of the shift clock (ADCCLK). The output channel is fed by an 8-bit shift register when the ADCCON bit of SYSCON3 is clear. When ADCCON is set, up to 16 bits of configuration command can be sent, as specified in the SYNCIO register. The input channel is captured by a 16-bit shift register. The clock and synchronization pulses are activated by a write to the output shift register. During transfers the SSIBUSY (synchronous serial interface busy) bit in the system status flags register is set. When the transfer is complete and valid data is in the 16-bit read shift register, the SSEOTI interrupt is asserted and the SSIBUSY bit is cleared.

An additional sample clock (SMPCLK) can be enabled independently and is set at twice the transfer clock frequency.

This interface has no local buffering capability and is only intended to be used with low bandwidth interfaces, such as for a touch-screen ADC interface.

### 3.13.4 Master / Slave SSI2 (Synchronous Serial Interface 2)

A second SPI / Microwire interface with full master / slave capability is provided by the EP7212. Data rates in slave mode are theoretically up to 512 kbits/s, full duplex, although continuous operation at this data rate will give an interrupt rate of 2 kHz, which is too fast for many operating systems. This would require a worst-case interrupt response time of less than 0.5 msec and would cause loss of data through TX underruns and RX overruns.

The interface is fully capable of being clocked at 512 kHz when in slave mode. However, it is anticipated that external hardware will be used to frame the data into packets. Therefore, although the data would be transmitted at a rate of 512 kbits/s, the sustained data rate would in fact only be 85.3 kbits/s (i.e., 1 byte every 750  $\mu$ sec). At this data rate, the required interrupt rate will be greater than 1 msec, which is acceptable.

There are separate half-word-wide RX and TX FIFOs (16 half-words each) and corresponding interrupts which are generated when the FIFO's are half-full or half-empty as appropriate. The inter-

SYSCON1 bit 17	SYSCON1 bit 16	13.0 MHz Operation ADCCLK Frequency (kHz)	18.432–73.728 MHz Operation ADCCLK Frequency (kHz)
0	0	4.2	4
0	1	16.9	16
1	0	67.7	64
1	1	135.4	128

**Table 23. ADC Interface Operation Frequencies**

rupts are called SS2RX and SS2TX, respectively. Register SS2DR is used to access the FIFOs.

There are five pins to support this SSI port: SSIRXDA, SSITXFR, SSICLK, SSITXDA, and SSIRXFR. The SSICLK, SSIRXDA, SSIRXFR, and SSITXFR signals are inputs and the SSITXDA signal is an output in slave mode. In the master mode, SSICLK, SSITXDA, SSITXFR, and SSIRXFR are outputs, and SSIRXDA is an input. Master mode is enabled by writing a one to the SS2MAEN bit (SYSCON2[9]). When the master / slave SSI is not required, it can be disabled to save power by writing a zero to the SS2TXEN and the SS2RXEN bits (SYSCON2[4] [7]). When set, these two bits independently enable the transmit and receive sides of the interface.

The master / slave SSI is synchronous, full duplex, and capable of supporting serial data transfers between two nodes. Although the interface is byte-oriented, data is loaded in blocks of two bytes at a time. Each data byte to be transferred is marked by a frame sync pulse, lasting one clock period, and located one clock prior to the first bit being transferred. Direction of the SSI2 ports, in slave and master mode, is shown in [Figure 9](#).

Data on the link is sent MSB first and coincides with an appropriate frame sync pulse, of one clock in duration, located one clock prior to the first data

bit sent (i.e., MSB). It is not possible to send data LSB first.

When operating in master mode, the clock frequency is selected to be the same as the ADC interface's (master mode only SSI1) — that is, the frequencies are selected by the same bits 16 and 17 of the SYSCON1 register (i.e., the ADCKSEL bits). Thus, the maximum frequency in master mode is 128 kbits/s. The interface will support continuous transmission at this rate assuming that the OS can respond to the interrupts within 1 msec to prevent over/underruns.

**NOTE:** To allow synchronization to the incoming slave clock, the interface enable bits will not take effect until one SSICLK cycle after they are written and the value read back from SYSCON2. The enable bits reflect the real status of the enables internally. Hence, there will be a delay before the new value programmed to the enable bits can be read back.

The timing diagram for this interface can be found in the *AC Characteristics* section of this document.

### 3.13.4.1 Read Back of Residual Data

All writes to the transmit FIFO must be in half-words (i.e., in units of two bytes at a time). On the receive side, it is possible that an odd number of bytes will be received. Bytes are always loaded into the receive FIFO in pairs. Consequently, in the case of a single residual byte remaining at the end of a transmission, it will be necessary for the software

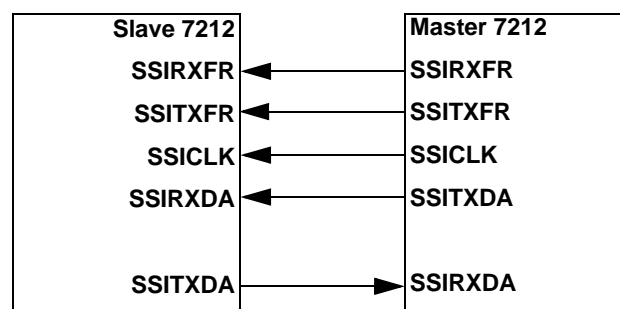

**Figure 9. SSI2 Port Directions in Slave and Master Mode**

to read the byte separately. This is done by reading the status of two bits in the SYSFLG2 register to determine the validity of the residual data. These two bits (RESVAL, RESFRM) are both set high when a residual is valid. RESVAL is cleared on either a new transmission or on reading of the residual bit by software. RESFRM is cleared only on a new transmission. By popping the residual byte into the RX FIFO and then reading the status of these bits it is possible to determine if a residual bit has been correctly read.

Figure 10 illustrates this procedure. The sequence is as follows: read the RESVAL bit, if this is a 0, no action needs to be taken. If this is a 1, then pop the residual byte into the FIFO by writing to the SS2POP location. Then read back the two status bits RESVAL and RESFRM. If these bits read back 01, then the residual byte popped into the FIFO is valid and can be read back from the SS2DR register. If the bits are not 01, then there has been another transmission received since the residual read procedure has been started. The data item that has been popped to the top of the FIFO will be invalid and should be ignored. In this case, the correct byte will have been stored in the most significant byte of the next half-word to be clocked into the FIFO.

**NOTE:** All the writes / reads to the FIFO are done word at a time (data on the lower 16 bits is valid and upper 16 bits are ignored).

Software manually pops the residual byte into the RX FIFO by writing to the SS2POP location (the value written is ignored). This write will strobe the RX FIFO write signal, causing the residual byte to be written into the FIFO.

**Figure 10. Residual Byte Reading**

### 3.13.4.2 Support for Asymmetric Traffic

The interface supports asymmetric traffic (i.e., unbalanced data flow). This is accomplished through separate transmit and receive frame sync control lines. In operation, the receiving node receives a byte of data on the eight clocks following the asser-

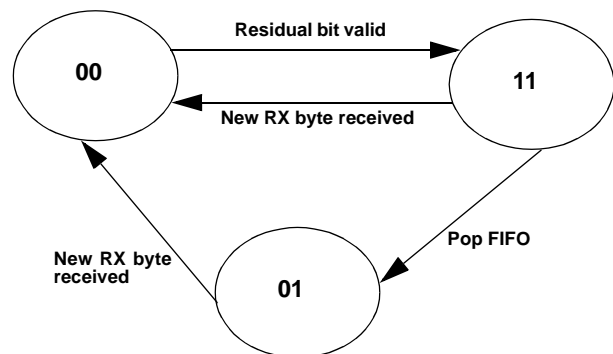

tion of the receive frame sync control line. In a similar fashion, the sending node can transmit a byte of data on the eight clocks following the assertion of the transmit frame sync pulse. There is no correlation in the frequency of assertions of the RX and TX frame sync control lines (SSITXFR and SSIRXFR). Hence, the RX path may bear a greater data throughput than the TX path, or vice versa. Both directions, however, have an absolute maximum data throughput rate determined by the maximum possible clock frequency, assuming that the interrupt response of the target OS is sufficiently quick.

### 3.13.4.3 Continuous Data Transfer

Data bytes may be sent / received in a contiguous manner without interleaving clocks between bytes. The frame sync control line(s) are eight clocks apart and aligned with the clock representing bit D0 of the preceding byte (i.e., one bit in advance of the MSB).

### 3.13.4.4 Discontinuous Clock

In order to save power during the idle times, the clock line is put into a static low state. The master is responsible for putting the link into the Idle State. The Idle State will begin one clock, or more, after the last byte transferred and will resume at least one clock prior to the first frame sync assertion. To disable the clock, the TX section is turned off.

In Master mode, the EP7212 does not support the discontinuous clock.

#### 3.13.4.5 Error Conditions

RX FIFO overflows are detected and conveyed via a status bit in the SYSFLG2 register. This register should be accessed at periodic intervals by the application software. The status register should be read each time the RX FIFO interrupts are generated. At this time the error condition (i.e., overrun flag) will indicate that an error has occurred but cannot convey which byte contains the error. Writing to the SRXEOF register location clears the overrun flag. TX FIFO underflow condition is detected and conveyed via a bit in the SYSFLG2 register, which is accessed by the application software. A TX underflow error is cleared by writing data to be transmitted to the TX FIFO.

#### 3.13.4.6 Clock Polarity

Clock polarity is fixed. TX data is presented on the bus on the rising edge of the clock. Data is latched into the receiving device on the falling edge of the clock. The TX pin is held in a tristate condition when not transmitting.

### 3.14 LCD Controller with Support for On-Chip Frame Buffer

The LCD controller provides all the necessary control signals to interface directly to a single panel multiplexed LCD. The panel size is programmable and can be any width (line length) from 32 to 1024 pixels in 16-pixel increments. The total video frame buffer size is programmable up to 128 kbytes. This equates to a theoretical maximum panel size of 1024 x 256 pixels in 4 bits-per-pixel mode. The video frame buffer can be located in any portion of memory controlled by the chip selects. Its start address will be fixed at address 0x0000000 within each chip select. The start address of the LCD video frame buffer is defined in the FBADDR[3:0] register. These bits become the most significant nibble of the external address bus. The default start address is 0xC000 0000 (FBADDR = 0xC). A system built using the on-chip SRAM

(OCSR), will then serve as the LCD video frame buffer and miscellaneous data store. The LCD video frame buffer start address should be set to 0x6 in this option. Programming of the register FBADDR is only permitted when the LCD is disabled (this is to avoid possible cycle corruption when changing the register contents while a LCD DMA cycle is in progress). There is no hardware protection to prevent this. It is necessary for the software to disable the LCD controller before reprogramming the FBADDR register. Full address decoding is provided for the OCSR, up to the maximum video frame buffer size programmable into the LCDCON register. Beyond this, the address is wrapped around. The frame buffer start address must not be programmed to 0x4 or 0x5 if either CL-PS6700 interface is in use (PCMEN1 or PCMEN2 bits in the SYSCON2 register are enabled). FBADDR should never be programmed to 0x7 or 0x8, as these are the locations for the on-chip Boot ROM and internal registers.

The screen is mapped to the video frame buffer as one contiguous block where each horizontal line of pixels is mapped to a set of consecutive bytes or words in the video RAM. The video frame buffer can be accessed word wide as pixel 0 is mapped to the LSB in the buffer such that the pixels are arranged in a little endian manner.

The pixel bit rate, and hence the LCD refresh rate, can be programmed from 18.432 MHz to 576 kHz when operating in 18.432–73.728 MHz mode, or 13 MHz to 203 kHz when operating from a 13 MHz clock. The LCD controller is programmed by writing to the LCD control register (LCDCON). The LCDCON register should not be reprogrammed while the LCD controller is enabled.

The LCD controller also contains two 32-bit palette registers, which allow any 4-, 2-, or 1-bit pixel value to be mapped to any of the 15 grayscale values available. The required DMA bandwidth to support a ½ VGA panel displaying 4 bits-per-pixel data at

an 80 Hz refresh rate is approximately 6.2 Mbytes/sec. Assuming the frame buffer is stored in a 32-bit wide the maximum theoretical bandwidth available is 86 Mbytes/sec at 36.864 MHz, or 29.7 Mbytes/sec at 13 MHz.

The LCD controller uses a nine stage 32-bit wide FIFO to buffer display data. The LCD controller requests new data when there are five words remaining in the FIFO. This means that for a ½ VGA display at 4 bits-per-pixel and 80 Hz refresh rate, the maximum allowable DMA latency is approximately 3.25  $\mu$ sec ( $(5 \text{ words} \times 8 \text{ bits/byte}) / (640 \times 240 \times 4\text{bpp} \times 80 \text{ Hz}) = 3.25 \mu\text{sec}$ ). The worst-case latency is the total number of cycles from when the DMA request appears to when the first DMA data word actually becomes available at the FIFO. DMA has the highest priority, so it will always happen next in the system. The maximum number of cycles required is 36 from the point at which the DMA request occurs to the point at which the STM is complete, then another 6 cycles before the data actually arrives at the FIFO from the first DMA read. This creates a total of 42 cycles. Assuming the frame buffer is located in 32-bit wide, the worst-case latency is almost exactly 3.2  $\mu$ s, with 13 MHz page mode cycles. With each cycle consuming ~77 ns (i.e., 1/13 MHz), the value of 3.2  $\mu$ s comes from 42 cycles  $\times$  77 ns/cycle = ~3.23  $\mu$ sec. If 16-bit wide, then the worst-case latency will double. In this case, the maximum permissible display size will be halved, to approximately 320  $\times$  240 pixels, assuming the same pixel depth and refresh rate has to be maintained. If the frame buffer is to be stored in static memory, then further calculations must be performed. If 18 MHz mode is selected, and 32-bit wide, then the worst-case latency will be 2.26  $\mu$ sec (i.e., 42 cycles  $\times$  54 nsec/cycle). If 36 MHz mode is selected, and 32-bit wide, then the worst-case latency drops down to 1.49  $\mu$ s. This calculation is a little more complex for 36 MHz mode of operation. The total number of cycles =  $(12 \times 4) + 7 = 55$ . Thus,  $55 \times 27 \text{ ns} = \sim 1.49 \mu\text{sec}$ .

Figure 11 shows the organization of the video map for all combinations of bits-per-pixel.

The refresh rate is not affected by the number of bits-per-pixel; however the LCD controller fetches twice the data per refresh for 4 bits-per-pixel compared to 2 bits-per-pixel. The main reason for reducing the number of bits-per-pixel is to reduce the power consumption of the memory where the video frame buffer is mapped.

### 3.15 Timer Counters

Two identical timer counters are integrated into the EP7212. These are referred to as TC1 and TC2. Each timer counter has an associated 16-bit read / write data register and some control bits in the system control register. Each counter is loaded with the value written to the data register immediately. This value will then be decremented on the second active clock edge to arrive after the write (i.e., after the first complete period of the clock). When the timer counter under flows (i.e., reaches 0), it will assert its appropriate interrupt. The timer counters can be read at any time. The clock source and mode are selectable by writing to various bits in the system control register. When run from the internal PLL, 512 kHz and 2 kHz rates are provided. When using the 13 MHz external source, the default frequencies will be 541 kHz and 2.115 kHz, respectively. However, only in non-PLL mode, an optional divide by 26 frequency can be generated (thus generating a 500 kHz frequency when using the 13 MHz source). This divider is enabled by setting the OSTB (Operating System Timing Bit) in the SYSCON2 register (bit 12). When this bit is set high to select the 500 kHz mode, the 500 kHz frequency is routed to the timers instead of the 541 kHz clock. This does not affect the frequencies derived for any of the other internal peripherals.

The timer counters can operate in two modes: free running or pre-scale.

### 3.15.1 Free Running Mode

In the free running mode, the counter will wrap around to 0xFFFF when it under flows and it will continue to count down. Any value written to TC1 or TC2 will be decremented on the second edge of the selected clock.

### 3.15.2 Prescale Mode

In the prescale mode, the value written to TC1 or TC2 is automatically re-loaded when the counter under flows. Any value written to TC1 or TC2 will be decremented on the second edge of the selected clock. This mode can be used to produce a programmable frequency to drive the buzzer (i.e., with TC1) or generate a periodic interrupt. The formula is  $F = (500 \text{ kHz}) / (n+1)$ .

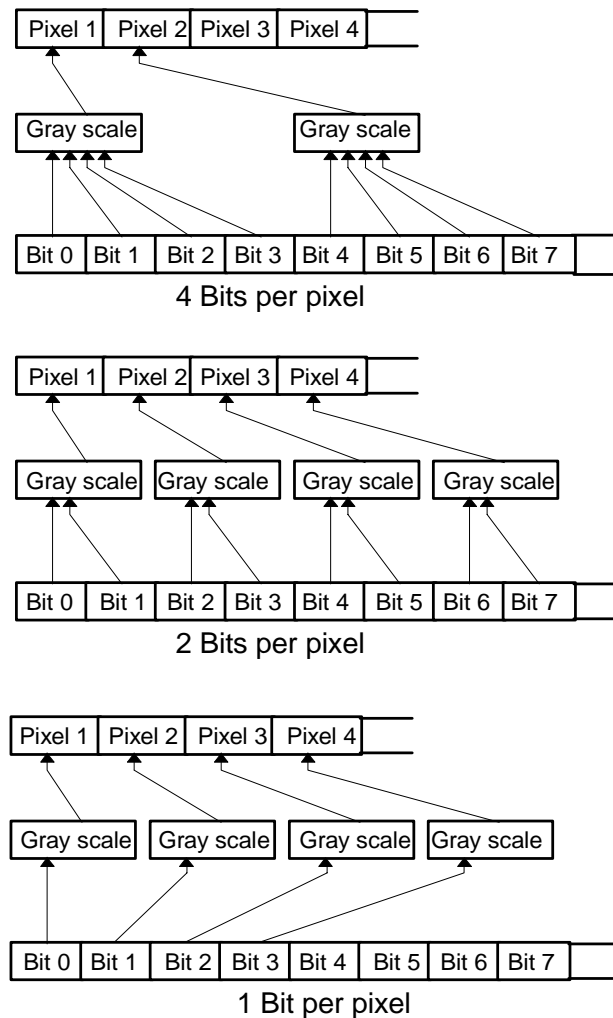

**Figure 11. Video Buffer Mapping**

### 3.16 Real Time Clock

The EP7212 contains a 32-bit Real Time Clock (RTC). This can be written to and read from in the same way as the timer counters, but it is 32 bits wide. The RTC is always clocked at 1 Hz, generated from the 32.768 kHz oscillator. It also contains a 32-bit output match register, this can be programmed to generate an interrupt when the time in the RTC matches a specific time written to this register. The RTC can only be reset by an nPOR cold reset. Because the RTC data register is updated from the 1 Hz clock derived from the 32 kHz source, which is asynchronous to the main memory system clock, the data register should always be read twice to ensure a valid and stable reading. This also applies when reading back the RTCDIV field of the SYSCON1 register, which reflects the status of the six LSBs of the RTC counter.

#### 3.16.1 Characteristics of the Real Time Clock Interface

When connecting a crystal to the RTC interface pins (i.e., RTCIN and RTCOUT), the crystal and circuit should conform to the following requirements:

- The 32.768 kHz frequency should be created by the crystals fundamental tone (i.e., it should be a fundamental mode crystal)
- A start-up resistor is not necessary, since one is provided internally.
- Start-up loading capacitors may be placed on each side of the external crystal and ground. Their value should be in the range of 10 pF. However, their values should be selected based upon the crystal specifications. The total sum of the capacitance of the traces between the EP7212's clock pins, the capacitors, and the crystal leads should be subtracted from the crystal's specifications when determining the values for the loading capacitors.

- The crystal should have a maximum 5 ppm frequency drift over the chip's operating temperature range.
- The voltage for the crystal must be  $2.5\text{ V} \pm 0.2\text{ V}$ .

Alternatively, a digital clock source can be used to drive the RTCIN pin of the EP7212. With this approach, the voltage levels of the clock source should match that of the  $V_{DD}$  supply for the EP7212's pads (i.e., the supply voltage level used to drive all of the non- $V_{DD}$  core pins on the EP7212) (i.e., RTCOUT). The output clock pin should be left floating.

### 3.17 Dedicated LED Flasher

The LED flasher feature enables an external pin (PD[0] / LEDFLSH) to be toggled at a programmable rate and duty ratio, with the intention that the external pin is connected to an LED. This module is driven from the RTCs 32.768 kHz oscillator and works in all running modes because no CPU intervention is needed once its rate and duty ratio have been configured (via the LEDFLSH register). The LED flash rate period can be programmed for 1, 2, 3, or 4 seconds. The duty ratio can be programmed such that the mark portion can be 1/16, 2/16... 16/16 of the full cycle. The external pin can provide up to 4 mA of drive current.

### 3.18 Two PWM Interfaces

Two Pulse Width Modulator (PWM) duty ratio clock outputs are provided by the EP7212. When the device is operating from the internal PLL, the PWM will run at a frequency of 96 kHz. These signals are intended for use as drives for external DC-to-DC converters in the Power Supply Unit (PSU) subsystem. External input pins that would normally be connected to the output from comparators monitoring the external DC-to-DC converter output are also used to enable these clocks. These are the FB[0:1] pins. The duty ratio (and hence PWMs on time) can be programmed from 1 in 16 to 15 in 16. The sense of the PWM drive signal (active high or

low) is determined by latching the state of this drive signal during power on reset (i.e., a pull-up on the drive signal will result in a active low drive output, and visa versa). This allows either positive or negative voltages to be generated by the external DC-to-DC converter. PWMs are disabled by writing zeros into the drive ratio fields in the PMPCON Pump Control register.

**NOTE:** To maximize power savings, the drive ratio fields should be used to disable the PWMs, instead of the FB pins. The clocks that source the PWMs are disabled when the drive ratio fields are zeroed.

### 3.19 Boundary Scan

IEEE 1149.1 compliant JTAG is provided with the EP7212. [Table 24](#) shows what instructions are supported in the EP7212.

Instruction	Code	Description
EXTEST	0000	Places the selected scan chain in test mode.
SCAN_N	0010	Connects the Scan Path Register between TDI and TDO
SAMPLE / PRE-LOAD	0011	<b>NOTE:</b> This instruction is included for product testing only and should never be used.
IDCODE	1110	Connects the ID register between TDI and TDO
BYPASS	1111	Connects a 1-bit shift register bit TDI and TDO

**Table 24. Instructions Supported in JTAG Mode**

The INTEST function will not be supported for the EP7212.

Additional user-defined instructions exist, but these are not relevant to board-level testing. For

further information please refer to the *ARM DDI 0087E ARM720T Data Sheet*.

As there are additional scan-chains within the ARM720T processor, it is necessary to include a scan-chain select function — shown as SCAN\_N in [Table 24](#). To select a particular scan chain, this function must be input to the TAP controller, followed by the 4-bit scan chain identification code. The identification code for the boundary scan chain is 0011.

Note that it is only necessary to issue the SCAN\_N instruction if the device is already in the JTAG mode. The boundary scan chain is selected as the default on test-logic reset and any of the system resets.

The contents of the device ID-register for the EP7212 are shown in [Table 25](#). This is equivalent to 0x0F0F0F0F. Note this is the ID-code for the ARM720T processor.

### 3.20 In-Circuit Emulation

#### 3.20.1 Introduction

EmbeddedICE™ is an extension to the architecture of the ARM family of processors, and provides the ability to debug cores that are deeply embedded into systems. It consists of three parts:

- 1) A set of extensions to the ARM core
- 2) The EmbeddedICE macrocell, which provides external access to the extensions
- 3) The EmbeddedICE interface, which provides communication between the host computer and the EmbeddedICE macrocell

The EmbeddedICE macrocell is programmed, in a serial fashion, through the TAP controller on the ARM via the JTAG interface. The EmbeddedICE macrocell is by default disabled to minimize power usage, and must be enabled at boot-up to support this functionality.

### 3.20.2 Functionality

The ICEBreaker module consists of two real-time watchpoint units together with a control and status register. One or both of the units can be programmed to halt the execution of the instructions by the ARM processor. Execution is halted when either a match occurs between the values programmed into the ICEBreaker and the values currently appearing on the address bus, data bus, and the various control signals. Any bit can be masked to remove it from the comparison. Either unit can be programmed as a watchpoint (monitoring data accesses) or a breakpoint (monitoring instruction fetches).

Using one of these watchpoint units, an unlimited number of software breakpoints (in RAM) can be supported by substitution of the actual code.

**NOTE:** The EXTERN[1:0] signals from the ICEBreaker module are not wired out in this device. This mechanism is used to allow watchpoints to be dependent on an external event. This behavior can be emulated in software via the ICEBreaker control registers.

A more detailed description is available in the ARM Software Development Toolkit User Guide and Reference Manual. The ICEBreaker module and its registers are fully described in the *ARM7TDMI Data Sheet*.

### 3.21 Maximum EP7212-Based System

A maximum configured system using the EP7212 is shown in [Figure 12](#). This system assumes all of the DRAMs and ROMs are 16-bit wide devices. The keyboard may be connected to more GPIO bits than shown to allow greater than 64 keys, however these extra pins will not be wired into the WAKE-UP pin functionality.

Version				Part number												Manufacturer ID															
0	0	0	0	1	1	1	1	0	0	0	0	1	1	1	1	0	0	0	0	1	1	1	1	0	0	0	0	1	1	1	1

**Table 25. Device ID Register**

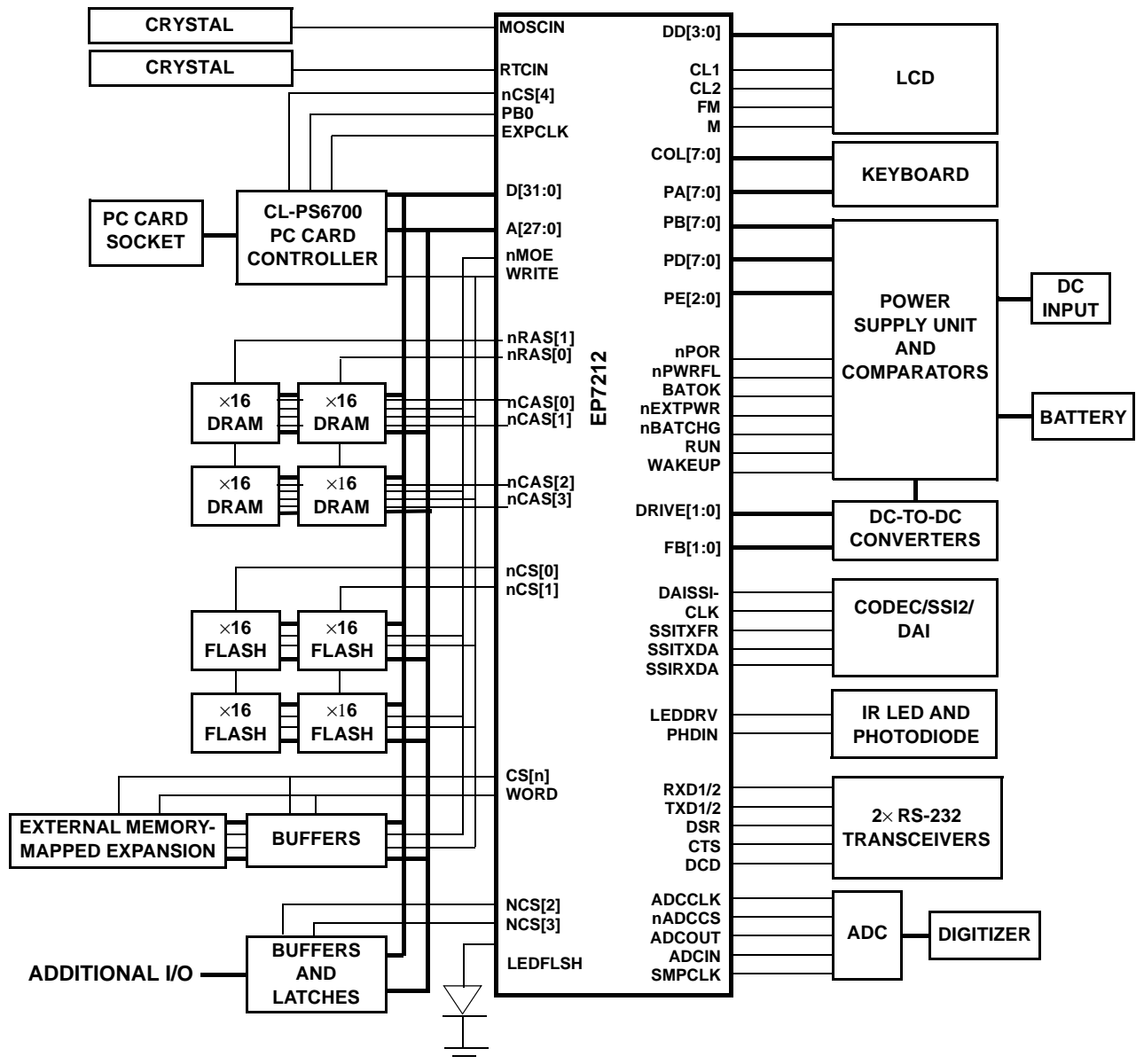

**NOTE:** A system can only use one of the following peripheral interfaces at any given time: SSI2, codec, or DAI.

Figure 12. A Maximum EP7212 Based System

#### 4. MEMORY MAP

The lower 2 GByte of the address space is allocated to memory. The 0.5 GByte of address space from 0xC0000000 to 0xDFFFFFFF is allocated to DRAM. The 1.5 GByte, less 8 kbytes for internal registers, is not accessible in the EP7212. The MMU in the EP7212 should be programmed to generate an abort exception for access to this area.

Internal peripherals are addressed through a set of internal memory locations from hex address 0x8000.0000 to 0x8000.3FFF. These are known as the internal registers in the EP7212. In [Table 26](#), the memory map from 0x8000.000 to 0x8000.1FFF contains registers that are compatible with the CL-PS7111 (see [Table 26](#)). These were in-

cluded for backward compatibility and are referred to as old internal registers.

[Table 26](#) shows how the 4-Gbyte address range of the ARM720T processor (as configured within this chip) is mapped in the EP7212. The memory map shown assumes that two CL-PS6700 PC Card controllers are connected. If this functionality is not required, then the nCS[4] and nCS[5] memory is available. The external boot ROM is not fully decoded (i.e., the boot code will repeat within the 256-Mbyte space from 0x70000000 to 0x80000000). See [Table 13 on page 30](#) for the memory map when booted from on chip boot ROM. The SRAM is fully decoded up to a maximum size of 128 kbytes. Access to any location above this range will be wrapped to within the range.

Address	Contents	Size
0xF000.0000	Reserved	256 Mbytes
0xE000.0000	Reserved	256 Mbytes
0xD000.0000	DRAM Bank 1	256 Mbytes
0xC000.0000	DRAM Bank 0	256 Mbytes
0x8000.4000	Unused	~1 Gbyte
0x8000.2000	Internal registers (new)	8 kbytes
0x8000.0000	Internal registers (old) (from 7111)	8 kbytes
0x7000.0000	Boot ROM (nCS[7])	128 bytes
0x6000.0000	SRAM (nCS[6])	38,400 bytes
0x5000.0000	PCMCIA-1 (nCS[5])	4 x 64 Mbytes
0x4000.0000	PCMCIA-0 (nCS[4])	4 x 64 Mbytes
0x3000.0000	Expansion (nCS[3])	256 Mbytes
0x2000.0000	Expansion (nCS[2])	256 Mbytes
0x1000.0000	ROM Bank 1 (nCS[1])	256 Mbytes
0x0000.0000	ROM Bank 0 (nCS[0])	256 Mbytes

**Table 26. EP7212 Memory Map in External Boot Mode**

## 5. REGISTER DESCRIPTIONS

### 5.1 Internal Registers

Table 27 shows the Internal Registers of the EP7212 that are compatible with the CL-PS7111 when the CPU is configured to a little endian memory system. Table 28 shows the differences that occur when the CPU is configured to a big endian memory system for byte-wide access to Ports A, B, and D. All the internal registers are inherently little endian (i.e., the least significant byte is attached to bits 7 to 0 of the data bus). Hence, the system Endianness affects the addresses required for byte accesses to the internal registers, resulting in a reversal of the byte address required to read / write a particular byte within a register. Note that the internal registers have been split into two groups – the “old” and the “new”. The old ones are the same as that used in CL-PS7111 and are there for compatibility. The new registers are for accessing the additional functionality of the DAI interface and the LED flasher.

There is no effect on the register addresses for word accesses. Bits A[0:1] of the internal address bus are only decoded for Ports A, B, and D (to allow read / write to individual ports). For all other registers, bits A[0:1] are not decoded, so that byte reads will return the whole register contents onto the EP7212’s internal bus, from where the appropriate byte (according to the endianness) will be read by the CPU. To avoid the additional complexity, it is preferable to perform all internal register accesses as word operations, except for ports A to D which are explicitly designed to operate with byte accesses, as well as with word accesses.

An 8 k segment of memory in the range 0x8000.0000 to 0x8000.3FFF is reserved for internal use in the EP7212. Accesses in this range will not cause any external bus activity unless debug mode is enabled. Writes to bits that are not explic-

itly defined in the internal area are legal and will have no effect. Reads from bits not explicitly defined in the internal area are legal but will read undefined values. All the internal addresses should only be accessed as 32-bit words and are always on a word boundary, except for the PIO port registers, which can be accessed as bytes. Address bits in the range A[0:5] are not decoded (except for Ports A–D), this means each internal register is valid for 64 bytes (i.e., the SYSFLG1 register appears at locations 0x8000.0140 to 0x8000.017C). There are some gaps in the register map for backward compatibility reasons, but registers located next to a gap are still only decoded for 64 bytes.

The GPIO port registers are byte-wide and can be accessed as a word but not as a half-word. These registers additionally decode A[0:1]. All addresses are in hexadecimal notation.

**NOTE:** All byte-wide registers should be accessed as words (except Port A to Port D registers, which are designed to work in both word and byte modes).

All registers bit alignment starts from the LSB of the register (i.e., they are all right shift justified).

The registers which interact with the 32 kHz clock or which could change during read-back (i.e., RTC data registers, SYSFLG1 register (lower 6-bits only), the TC1D and TC2D data registers, port registers, and interrupt status registers), should be read twice and compared to ensure that a stable value has been read back.

All internal registers in the EP7212 are reset (cleared to zero) by a system reset (i.e., nPOR, nRESET, or nPWRFL signals becoming active), and the Real Time Clock data register (RTCDCR) and match register (RTCMR), which are only reset by nPOR becoming active. This ensures that the system time preserved through a user reset or power fail condition. In the following register descriptions, little endian is assumed.

Address	Name	Default	RD/WR	Size	Comments
0x8000.0000	PADR	0	RW	8	Port A data register
0x8000.0001	PBDR	0	RW	8	Port B data register
0x8000.0002	—		—	8	Reserved
0x8000.0003	PDDR	0	RW	8	Port D data register
0x8000.0040	PADDR	0	RW	8	Port A data direction register
0x8000.0041	PBDDR	0	RW	8	Port B data direction register
0x8000.0042	—		—	8	Reserved
0x8000.0043	PDDDR	0	RW	8	Port D data direction register
0x8000.0080	PEDR	0	RW	3	Port E data register
0x8000.00C0	PEDDR	0	RW	3	Port E data direction register
0x8000.0100	SYSCON1	0	RW	32	System control register 1
0x8000.0140	SYSFLG1	0	RD	32	System status flags register 1
0x8000.0180	MEMCFG1	0	RW	32	Expansion memory configuration register 1
0x8000.01C0	MEMCFG2	0	RW	32	Expansion memory configuration register 2
0x8000.0200	DRFPR	0	RW	8	DRAM refresh period register
0x8000.0240	INTSR1	0	RD	32	Interrupt status register 1
0x8000.0280	INTMR1	0	RW	32	Interrupt mask register 1
0x8000.02C0	LCDCON	0	RW	32	LCD control register
0x8000.0300	TC1D	0	RW	16	Read / Write register sets and reads data to TC1
0x8000.0340	TC2D	0	RW	16	Read / Write register sets and reads data to TC2
0x8000.0380	RTCDR	—	RW	32	Real Time Clock data register
0x8000.03C0	RTCMR	—	RW	32	Real Time Clock match register
0x8000.0400	PMPCON	0	RW	12	PWM pump control register
0x8000.0440	CODR	0	RW	8	CODEC data I/O register
0x8000.0480	UARTDR1	0	RW	16	UART1 FIFO data register
0x8000.04C0	UBLCR1	0	RW	32	UART1 bit rate and line control register
0x8000.0500	SYNCIO	0	RW	32	Synchronous serial I/O data register for master only SSI
0x8000.0540	PALLSW	0	RW	32	Least significant 32-bit word of LCD palette register
0x8000.0580	PALMSW	0	RW	32	Most significant 32-bit word of LCD palette register
0x8000.05C0	STFCLR	—	WR	—	Write to clear all start up reason flags
0x8000.0600	BLEOI	—	WR	—	Write to clear battery low interrupt
0x8000.0640	MCEOI	—	WR	—	Write to clear media changed interrupt
0x8000.0680	TEOI	—	WR	—	Write to clear tick and watchdog interrupt
0x8000.06C0	TC1EOI	—	WR	—	Write to clear TC1 interrupt
0x8000.0700	TC2EOI	—	WR	—	Write to clear TC2 interrupt

**Table 27. EP7212 Internal Registers (Little Endian Mode)**

Address	Name	Default	RD/WR	Size	Comments
0x8000.0740	RTCEOI	—	WR	—	Write to clear RTC match interrupt
0x8000.0780	UMSEOI	—	WR	—	Write to clear UART modem status changed interrupt
0x8000.07C0	COEOI	—	WR	—	Write to clear CODEC sound interrupt
0x8000.0800	HALT	—	WR	—	Write to enter the Idle State
0x8000.0840	STDBY	—	WR	—	Write to enter the Standby State
0x8000.0880– 0x8000.0FFF	Reserved				Write will have no effect, read is undefined
0x8000.1000	FBADDR	0xC	RW	4	LCD frame buffer start address
0x8000.1100	SYSCON2	0	RW	16	System control register 2
0x8000.1140	SYSFLG2	0	RD	24	System status register 2
0x8000.1240	INTSR2	0	RD	24	Interrupt status register 2
0x8000.1280	INTMR2	0	RW	16	Interrupt mask register 2
0x8000.12C0– 0x8000.147F	Reserved				Write will have no effect, read is undefined
0x8000.1480	UARTDR2	0	RW	16	UART2 Data Register
0x8000.14C0	UBLCR2	0	RW	32	UART2 bit rate and line control register
0x8000.1500	SS2DR	0	RW	16	Master / slave SSI2 data Register
0x8000.1600	SRXEOF	—	WR	—	Write to clear RX FIFO overflow flag
0x8000.16C0	SS2POP	—	WR	—	Write to pop SSI2 residual byte into RX FIFO
0x8000.1700	KBDEOI	—	WR	—	Write to clear keyboard interrupt
0x8000.1800	Reserved	—	WR	—	Do not write to this location. A write will cause the processor to go into an unsupported power savings state.
0x8000.1840– 0x8000.1FFF	Reserved	—			Write will have no effect, read is undefined
0x8000.2000	DAIR *	0	RW	32	DAI control register
0x8000.2040	DAIR0 *	0	RW	32	DAI data register 0
0x8000.2080	DAIDR1 *	0	RW	32	DAI data register 1
0x8000.20C0	DAIDR2 *	0	WR	21	DAI data register 2
0x8000.2100	DAISR *	0	RW	32	DAI status register
0x8000.2200	SYSCON *	0	RW	16	System control register 3
0x8000.2240	INTSR3 *	0	RD	32	Interrupt status register 3
0x8000.2280	INTMR3 *	0	RW	8	Interrupt mask register 3
0x8000.22C0	LEDFLSH *	0	RW	7	LED Flash register

**Table 27. EP7212 Internal Registers (Little Endian Mode) (cont.)**

\* Internal registers that are not backward compatible with the CL-PS7111.

Big Endian Mode	Name	Default	RD/WR	Size	Comments
0x8000.0003	PADR	0	RW	8	Port A Data Register
0x8000.0002	PBDR	0	RW	8	Port B Data Register
0x8000.0001	—		—	8	Reserved
0x8000.0000	PDDR	0	RW	8	Port D Data Register
0x8000.0043	PADDR	0	RW	8	Port A data Direction Register
0x8000.0042	PBDDR	0	RW	8	Port B Data Direction Register
0x8000.0041	—		—	8	Reserved
0x8000.0040	PDDDR	0	RW	8	Port D Data Direction Register
0x0000.0080	PEDR	0	RW	3	Port E Data Register
0X8000.0000	PEDDR	0	RW	3	Port E Data Direction Register

**Table 28. EP7212 Internal Registers (Big Endian Mode)**

All internal registers in the IP7212 are reset (cleared to zero) by a system reset (i.e., nPOR, nURESET, or nPWRFL signals becoming active), except for the DRAM refresh period register (DPFPR), the Real Time Clock data register (RTCDR), and the match register (RTCMR), which are only reset by nPOR becoming active. This ensures that the DRAM contents and system time are preserved through a user reset or power fail condition.

**NOTE:** The following Register Descriptions refer to Little Endian Mode Only

### 5.1.1 *PADR Port A Data Register*

ADDRESS: 0x8000.0000

Values written to this 8-bit read / write register will be output on Port A pins if the corresponding data direction bits are set high (port output). Values read from this register reflect the external state of Port A, not necessarily the value written to it. All bits are cleared by a system reset.

### 5.1.2 *PBDR Port B Data Register*

ADDRESS: 0x8000.0001

Values written to this 8-bit read / write register will be output on Port B pins if the corresponding data direction bits are set high (port output). Values read from this register reflect the external state of Port B, not necessarily the value written to it. All bits are cleared by a system reset.

### 5.1.3 *PDDR Port D Data Register*

ADDRESS: 0x8000.0003

Values written to this 8-bit read / write register will be output on Port D pins if the corresponding data direction bits are set low (port output). Values read from this register reflect the external state of Port D, not necessarily the value written to it. All bits are cleared by a system reset.

### 5.1.4 PADDR Port A Data Direction Register

ADDRESS: 0x8000.0040

Bits set in this 8-bit read / write register will select the corresponding pin in Port A to become an output, clearing a bit sets the pin to input. All bits are cleared by a system reset.

### 5.1.5 PBDDR Port B Data Direction Register

ADDRESS: 0x8000.0041

Bits set in this 8-bit read / write register will select the corresponding pin in Port B to become an output, clearing a bit sets the pin to input. All bits are cleared by a system reset.

### 5.1.6 PDDDR Port D Data Direction Register

ADDRESS: 0x8000.0043

Bits cleared in this 8-bit read / write register will select the corresponding pin in Port D to become an output, setting a bit sets the pin to input. All bits are cleared by a system reset so that Port D is output by default.

### 5.1.7 PEDR Port E Data Register

ADDRESS: 0x8000.0080

Values written to this 3-bit read / write register will be output on Port E pins if the corresponding data direction bits are set high (port output). Values read from this register reflect the external state of Port E, not necessarily the value written to it. All bits are cleared by a system reset.

### 5.1.8 PEDDR Port E Data Direction Register

ADDRESS: 0x8000.00C0

Bits set in this 3-bit read / write register will select the corresponding pin in Port E to become an output, while the clearing bit sets the pin to input. All bits are cleared by a system reset so that Port E is input by default.

## 5.2 SYSTEM Control Registers

### 5.2.1 SYSCON1 The System Control Register 1

ADDRESS: 0x8000.0100

23	22	21	20	19	18
			IRTXM	WAKEDIS	EXCKEN
17:16	15	14	13	12	11
ADCKSEL	SIREN	CDENRX	CDENTX	LCDEN	DBGEN
7	6	5	4	3:0	
TC2S	TC2M	TC1S	TC1M	Keyboard scan	

The system control register is a 21-bit read / write register which controls all the general configuration of the EP7212, as well as modes etc. for peripheral devices. All bits in this register are cleared by a system reset. The bits in the system control register SYSCON1 are defined in [Table 29](#).

Bit	Description																								
0:3	<p><b>Keyboard scan:</b> This 4-bit field defines the state of the keyboard column drives. The following table defines these states.</p> <table border="1" style="margin-left: 40px;"> <thead> <tr> <th style="text-align: center;">Keyboard Scan</th> <th style="text-align: center;">Column</th> </tr> </thead> <tbody> <tr> <td style="text-align: center;">0</td> <td>All driven high</td> </tr> <tr> <td style="text-align: center;">1</td> <td>All driven low</td> </tr> <tr> <td style="text-align: center;">2–7</td> <td>All high impedance (tristate)</td> </tr> <tr> <td style="text-align: center;">8</td> <td>Column 0 only driven high all others high impedance</td> </tr> <tr> <td style="text-align: center;">9</td> <td>Column 1 only driven high all others high impedance</td> </tr> <tr> <td style="text-align: center;">10</td> <td>Column 2 only driven high all others high impedance</td> </tr> <tr> <td style="text-align: center;">11</td> <td>Column 3 only driven high all others high impedance</td> </tr> <tr> <td style="text-align: center;">12</td> <td>Column 4 only driven high all others high impedance</td> </tr> <tr> <td style="text-align: center;">13</td> <td>Column 5 only driven high all others high impedance</td> </tr> <tr> <td style="text-align: center;">14</td> <td>Column 6 only driven high all others high impedance</td> </tr> <tr> <td style="text-align: center;">15</td> <td>Column 7 only driven high all others high impedance</td> </tr> </tbody> </table>	Keyboard Scan	Column	0	All driven high	1	All driven low	2–7	All high impedance (tristate)	8	Column 0 only driven high all others high impedance	9	Column 1 only driven high all others high impedance	10	Column 2 only driven high all others high impedance	11	Column 3 only driven high all others high impedance	12	Column 4 only driven high all others high impedance	13	Column 5 only driven high all others high impedance	14	Column 6 only driven high all others high impedance	15	Column 7 only driven high all others high impedance
Keyboard Scan	Column																								
0	All driven high																								
1	All driven low																								
2–7	All high impedance (tristate)																								
8	Column 0 only driven high all others high impedance																								
9	Column 1 only driven high all others high impedance																								
10	Column 2 only driven high all others high impedance																								
11	Column 3 only driven high all others high impedance																								
12	Column 4 only driven high all others high impedance																								
13	Column 5 only driven high all others high impedance																								
14	Column 6 only driven high all others high impedance																								
15	Column 7 only driven high all others high impedance																								
4	<b>TC1M:</b> Timer counter 1 mode. Setting this bit sets TC1 to prescale mode, clearing it sets free running mode.																								
5	<b>TC1S:</b> Timer counter 1 clock source. Setting this bit sets the TC1 clock source to 512 kHz, clearing it sets the clock source to 2 kHz.																								
6	<b>TC2M:</b> Timer counter 2 mode. Setting this bit sets TC2 to prescale mode, clearing it sets free running mode.																								
7	<b>TC2S:</b> Timer counter 2 clock source. Setting this bit sets the TC2 clock source to 512 kHz, clearing it sets the clock source to 2 kHz.																								
8	<b>UART1EN:</b> Internal UART enable bit. Setting this bit enables the internal UART.																								
9	<b>BZTOG:</b> Bit to drive (i.e., toggle) the buzzer output directly when software mode of operation is selected (i.e., bit BZMOD = 0). See the BZMOD and BUZFREQ (SYSCON1) bits for more details.																								
10	<b>BZMOD:</b> This bit selects the buzzer drive mode. When BZMOD = 0, the buzzer drive output pin is connected directly to the BZTOG bit. This is the software mode. When BZMOD = 1, the buzzer drive is in the hardware mode. Two hardware sources are available to drive the pin. They are the TC1 or a fixed internally generated clock source. The selection of which source is used to drive the pin is determined by the state of the BUZFREQ bit in the SYSCON2 register. If the TC1 is selected, then the buzzer output pin is connected to the TC1 under flow bit. The buzzer output pin changes every time the timer wraps around. The frequency depends on what was programmed into the timer. See the description of the BUZFREQ and BZTOG bits (SYSCON2) for more details.																								

**Table 29. SYSCON1**

Bit	Description															
11	<p><b>DBGEN:</b> Setting this bit will enable the debug mode. In this mode, all internal accesses are output as if they were reads or writes to the expansion memory addressed by nCS5. nCS5 will still be active in its standard address range. In addition, the internal interrupt request and fast interrupt request signals to the ARM720T processor are output on Port E, bits 1 and 2. Note that these bits must be programmed to be outputs before this functionality can be observed. The clock to the CPU is output on Port E, Bit 0 to delineate individual accesses. For example, in debug mode:</p> <p style="margin-left: 40px;">nCS5 = nCS5 or internal I/O strobe  PE0 = CLK  PE1 = nIRQ  PE2 = nFIQ</p>															
12	<b>LCDEN:</b> LCD enable bit. Setting this bit enables the LCD controller.															
13	<b>CDENTX:</b> Codec interface enable TX bit. Setting this bit enables the codec interface for data transmission to an external codec device.															
14	<p><b>CDENRX:</b> Codec interface enable RX bit. Setting this bit enables the codec interface for data reception from an external codec device.</p> <p><b>NOTE:</b> Both CDENRX and CDENTX need to be enabled / disabled in tandem, otherwise data may be lost.</p>															
15	<b>SIREN:</b> HP SIR protocol encoding enable bit. This bit will have no effect if the UART is not enabled.															
16:17	<p><b>ADCKSEL:</b> Microwire / SPI peripheral clock speed select. This two-bit field selects the frequency of the ADC sample clock, which is twice the frequency of the synchronous serial ADC interface clock. The table below shows the available frequencies for operation when in PLL mode. These bits are also used to select the shift clock frequency for the SSI2 interface when set into master mode. The frequencies obtained in 13.0 MHz mode can be found in <a href="#">Table 23</a>.</p> <table border="1" style="margin-left: auto; margin-right: auto;"> <thead> <tr> <th style="text-align: center;">ADCKSEL</th> <th style="text-align: center;">ADC Sample Frequency (kHz) — SMPCLK</th> <th style="text-align: center;">ADC Clock Frequency (kHz) — ADCCLK</th> </tr> </thead> <tbody> <tr> <td style="text-align: center;">00</td> <td style="text-align: center;">8</td> <td style="text-align: center;">4</td> </tr> <tr> <td style="text-align: center;">01</td> <td style="text-align: center;">32</td> <td style="text-align: center;">16</td> </tr> <tr> <td style="text-align: center;">10</td> <td style="text-align: center;">128</td> <td style="text-align: center;">64</td> </tr> <tr> <td style="text-align: center;">11</td> <td style="text-align: center;">256</td> <td style="text-align: center;">128</td> </tr> </tbody> </table>	ADCKSEL	ADC Sample Frequency (kHz) — SMPCLK	ADC Clock Frequency (kHz) — ADCCLK	00	8	4	01	32	16	10	128	64	11	256	128
ADCKSEL	ADC Sample Frequency (kHz) — SMPCLK	ADC Clock Frequency (kHz) — ADCCLK														
00	8	4														
01	32	16														
10	128	64														
11	256	128														
18	<b>EXCKEN:</b> External expansion clock enable. If this bit is set, the EXPCLK is enabled continuously as a free running clock with the same frequency and phase as the CPU clock, assuming that the main oscillator is running. This bit should not be left set all the time for power consumption reasons. If the system enters the Standby State, the EXPCLK will become undefined. If this bit is clear, EXPCLK will be active during memory cycles to expansion slots that have external wait state generation enabled only.															
19	<b>WAKEDIS:</b> Setting this bit disables waking up from the Standby State, via the wakeup input.															
20	<b>IRTXM:</b> IrDA TX mode bit. This bit controls the IrDA encoding strategy. Clearing this bit means that each zero bit transmitted is represented as a pulse of width 3/16th of the bit rate period. Setting this bit means each zero bit is represented as a pulse of width 3/16th of the period of 115,200-bit rate clock (i.e., 1.6 μsec regardless of the selected bit rate). Setting this bit will use less power, but will probably reduce transmission distances.															

**Table 29. SYSCON1 (cont.)**

### 5.2.2 SYSCON2 System Control Register 2

ADDRESS: 0x8000.1100

15	14	13	12	11:10	9	8
Reserved	BUZFREQ	CLKENSL	OSTB	Reserved	SS2MAEN	UART2EN
7	6	5	4	3	2	1
SS2RXEN	PC CARD2	PC CARD1	SS2TXEN	KBWEN	DRAMSZ	KBD6
						0
						SERSEL

This register is an extension of SYSCON1, containing additional control for the EP7212, for compatibility with CL-PS7111. The bits of this second system control register are defined below. The SYSCON2 register is reset to all 0s on power up.

Bit	Description						
0	<p><b>SERSEL:</b> The only affect of this bit is to select either SSI2 or the codec to interface to the external pins. See the table below for the selection options.</p> <p><b>NOTE:</b> If the DAISEL bit of SYSCON3 is set, then it overrides the state of the SERSEL bit, and thus the external pins are connected to the DAI interface.</p> <table border="1" style="margin-left: auto; margin-right: auto;"> <thead> <tr> <th style="text-align: center;">SERSEL Value</th> <th style="text-align: center;">Selected Serial Device to External Pins</th> </tr> </thead> <tbody> <tr> <td style="text-align: center;">0</td> <td style="text-align: center;">Master / slave SSI2</td> </tr> <tr> <td style="text-align: center;">1</td> <td style="text-align: center;">Codec</td> </tr> </tbody> </table>	SERSEL Value	Selected Serial Device to External Pins	0	Master / slave SSI2	1	Codec
SERSEL Value	Selected Serial Device to External Pins						
0	Master / slave SSI2						
1	Codec						
1	<p><b>KBD6:</b> The state of this bit determines how many of the Port A inputs are OR'ed together to create the keyboard interrupt. When zero (the reset state), all eight of the Port A inputs will generate a keyboard interrupt. When set high, only Port A bits 0 to 5 will generate an interrupt from the keyboard. It is assumed that the keyboard row lines are connected into Port A.</p>						
2	<p><b>DRAMZ:</b> This bit determines the width of the DRAM memory interface, where: 0=32-bit DRAM and 1=16-bit DRAM.</p>						
3	<p><b>KBWEN:</b> When the KBWEN bit is high, the EP7212 will awaken from a power saving state into the Operating State when a high signal is on one of Port A's inputs (irrespective of the state of the interrupt mask register). This is called the Keyboard Direct Wakeup mode. In this mode, the interrupt request does not have to get serviced. If the interrupt is masked (i.e., the interrupt mask register 2 (INTMR2) bit 0 is low), the processor simply starts re-executing code from where it left off before it entered the power saving state. If the interrupt is non-masked, then the processor will service the interrupt.</p>						
4	<p><b>SS2TXEN:</b> Transmit enable for the synchronous serial interface 2. The transmit side of SSI2 will be disabled until this bit is set. When set low, this bit also disables the SSICLK pin (to save power) in master mode, if the receive side is low.</p>						
5	<p><b>PC CARD1:</b> Enable for the interface to the CL-PS6700 device for PC Card slot 1. The main effect of this bit is to reassign the functionality of Port B, bit 0 to the PRDY input from the CL-PS6700 devices, and to ensure that any access to the nCS4 address space will be according to the CL-PS6700 interface protocol.</p>						

**Table 30. SYSCON2**

Bit	Description
6	<b>PC CARD2:</b> Enable for the interface to the CL-PS6700 device for PC Card slot 2. The main effect of this bit is to reassign the functionality of Port B, bit 1 to the PRDY input from the CL-PS6700 devices and to ensure that any access to the nCS5 address space will be according to the CL-PS6700 interface protocol.
7	<b>SS2RXEN:</b> Receive enable for the synchronous serial interface 2. The receive side of SSI2 will be disabled until this bit is set. When both SSI2TXEN and SSI2RXEN are disabled, the SSI2 interface will be in a power saving state.
8	<b>UART2EN:</b> Internal UART2 enable bit. Setting this bit enables the internal UART2.
9	<b>SS2MAEN:</b> Master mode enable for the synchronous serial interface 2. When low, SSI2 will be configured for slave mode operation. When high, SSI2 will be configured for master mode operation. This bit also controls the directionality of the interface pins.
12	<b>OSTB:</b> This bit (operating system timing bit) is for use only with the 13 MHz clock source mode. Normally it will be set low, however when set high it will cause a 500 kHz clock to be generated for the timers instead of the 541 kHz which would normally be available. The divider to generate this frequency is not clocked when this bit is set low.
13	<b>CLKENSL:</b> CLKEN select. When low, the CLKEN signal will be output on the RUN/CLKEN pin. When high, the RUN signal will be output on RUN/CLKEN.
14	<b>BUZFREQ:</b> The BUZFREQ bit is used to select which hardware source will be used as the source to drive the buzzer output pin. When BUZFREQ = 0, the buzzer signal generated from the on-chip timer (TC1) is output. When BUZFREQ = 1, a fixed frequency clock is output (500 Hz when running from the PLL, 528 Hz in the 13 MHz external clock mode). See the BZMOD and the BZTOG bits (SYSICON2) for more details.

**Table 30. SYSICON2 (cont.)**

### 5.2.3 SYSCON3 System Control Register 3

ADDRESS: 0x8000.2200

15	14	13	12	11	10	9	8
Reserved	Reserved	Reserved	Reserved	Reserved	Reserved	DAIEN	FASTWAKE
7	6	5	4	3	2	1	0
VERSN[2] Reserved	VERSN[1] Reserved	VERSN[0] Reserved	ADCCKNSEN	DAISEL	CLKCTL1	CLKCTL0	ADCCON

This register is an extension of SYSCON1 and SYSCON2, containing additional control for the EP7212. The bits of this third system control register are defined in [Table 31](#).

Bit	Description																				
0	<b>ADCCON</b> : Determines whether the ADC Configuration Extension field SYNCIO(31:16) is to be used for ADC configuration data. When this bit = 0 (default state) the ADC Configuration Byte SYNCIO(7:0) only is used for compatibility with the CL-PS7111. When this bit = 1, the ADC Configuration Extension field in the SYNCIO register is used for ADC Configuration data and the value in the ADC Configuration Byte (SYNCIO(6:0)) selects the length of the data (8-bit to 16-bit).																				
1:2	<b>CLKCTL(1:0)</b> : Determines the frequency of operation of the processor and Wait State scaling. The table below lists the available options. <table border="1" data-bbox="414 955 1377 1207"> <thead> <tr> <th>CLKCTL(1:0) Value</th><th>Processor Frequency</th><th>Memory Bus Frequency</th><th>Wait State Scaling</th></tr> </thead> <tbody> <tr> <td>00</td><td>18.432 MHz</td><td>18.432 MHz</td><td>1</td></tr> <tr> <td>01</td><td>36.864 MHz</td><td>36.864 MHz</td><td>2</td></tr> <tr> <td>10</td><td>49.152 MHz</td><td>36.864 MHz</td><td>2</td></tr> <tr> <td>11</td><td>73.728 MHz</td><td>36.864 MHz</td><td>2</td></tr> </tbody> </table> <p><b>NOTE:</b> To determine the number of wait states programmed refer to <a href="#">Table 38</a> and <a href="#">Table 39</a>. When operating at 13 MHz, the CLKCTL[1:0] bits should not be changed from the default value of '00'. Under no circumstances should the CLKCTL bits be changed using a buffered write.</p>	CLKCTL(1:0) Value	Processor Frequency	Memory Bus Frequency	Wait State Scaling	00	18.432 MHz	18.432 MHz	1	01	36.864 MHz	36.864 MHz	2	10	49.152 MHz	36.864 MHz	2	11	73.728 MHz	36.864 MHz	2
CLKCTL(1:0) Value	Processor Frequency	Memory Bus Frequency	Wait State Scaling																		
00	18.432 MHz	18.432 MHz	1																		
01	36.864 MHz	36.864 MHz	2																		
10	49.152 MHz	36.864 MHz	2																		
11	73.728 MHz	36.864 MHz	2																		
3	<b>DAISEL</b> : When set selects the DAI Interface. This defaults to either the SSI (i.e., DAISEL bit is low).																				
4	<b>ADCCKNSEN</b> : When set, configuration data is transmitted on ADCOUT at the rising edge of the ADCCLK, and data is read back on the falling edge on the ADCIN pin. When clear (default), the opposite edges are used.																				
5:7	<b>VERSN[0:2]</b> : Additional read-only version bits — will read '001' for Revision C and '010' for Revision D EP7212 chips.																				
8	<b>FASTWAKE</b> : When set, the device will wake from the Standby State within one to two cycles of a 4 kHz clock. This bit is cleared at power up, and thus the device first starts using the default one to two cycles of the 8 Hz clock.																				
9	<b>DAIEN</b> : This bit enables the Digital Audio Interface when set (i.e., when DAIEN is high).																				

**Table 31. SYSCON3**

### 5.2.4 *SYSFLG1 — The System Status Flags Register*

ADDRESS: 0x8000.0140

<b>31:30</b>	<b>29</b>	<b>28</b>	<b>27</b>	<b>26</b>
VERID	ID	BOOTBIT1	BOOTBIT0	SSIBUSY
<b>23</b>	<b>22</b>	<b>21:16</b>	<b>23</b>	<b>22</b>
UTXFF1	URXFE1	RTCDIV	UTXFF1	URXFE1
<b>15</b>	<b>14</b>	<b>13</b>	<b>12</b>	<b>11</b>
CLDFLG	PFFLG	RSTFLG	NBFLG	UBUSY1
<b>7:4</b>	<b>3</b>	<b>2</b>	<b>1</b>	<b>0</b>
DID	WUON	WUDR	DCDET	MCDR

The system status flags register is a 32-bit read only register, which indicates various system information. The bits in the system status flags register SYSFLG1 are defined in [Table 32](#).

Bit	Description
0	<b>MCDR</b> : Media changed direct read. This bit reflects the INVERTED non-latched status of the media changed input.
1	<b>DCDET</b> : This bit will be set if a non-battery operated power supply is powering the system (it is the inverted state of the nEXTPWR input pin).
2	<b>WUDR</b> : Wake up direct read. This bit reflects the non-latched state of the wakeup signal.
3	<b>WUON</b> : This bit will be set if the system has been brought out of the Standby State by a rising edge on the wakeup signal. It is cleared by a system reset or by writing to the HALT or STDBY locations.
4:7	<b>DID</b> : Display ID nibble. This 4-bit nibble reflects the latched state of the four LCD data lines. The state of the four LCD data lines is latched by the LCDEN bit, and so it will always reflect the last state of these lines before the LCD controller was enabled.
8	<b>CTS</b> : This bit reflects the current status of the clear to send (CTS) modem control input to UART1.
9	<b>DSR</b> : This bit reflects the current status of the data set ready (DSR) modem control input to UART1.
10	<b>DCD</b> : This bit reflects the current status of the data carrier detect (DCD) modem control input to UART1.
11	<b>UBUSY1</b> : UART1 transmitter busy. This bit is set while UART1 is busy transmitting data, it is guaranteed to remain set until the complete byte has been sent, including all stop bits.
12	<b>NBFLG</b> : New battery flag. This bit will be set if a low to high transition has occurred on the nBATCHG input, it is cleared by writing to the STFCLR location.
13	<b>RSTFLG</b> : Reset flag. This bit will be set if the RESET button has been pressed, forcing the nURESET input low. It is cleared by writing to the STFCLR location.
14	<b>PFFLG</b> : Power Fail Flag. This bit will be set if the system has been reset by the nPWRFL input pin, it is cleared by writing to the STFCLR location.
15	<b>CLDFLG</b> : Cold start flag. This bit will be set if the EP7212 has been reset with a power on reset, it is cleared by writing to the STFCLR location.

**Table 32. SYSFLG**

Bit	Description															
16:21	<b>RTCDIV</b> : This 6-bit field reflects the number of 64 Hz ticks that have passed since the last increment of the RTC. It is the output of the divide by 64 chain that divides the 64 Hz tick clock down to 1 Hz for the RTC. The MSB is the 32 Hz output, the LSB is the 1 Hz output.															
22	<b>URXFE1</b> : UART1 receiver FIFO empty. The meaning of this bit depends on the state of the UFI-FOEN bit in the UART1 bit rate and line control register. If the FIFO is disabled, this bit will be set when the RX holding register is empty. If the FIFO is enabled, the URXFE bit will be set when the RX FIFO is empty.															
23	<b>UTXFF1</b> : UART1 transmit FIFO full. The meaning of this bit depends on the state of the UFI-FOEN bit in the UART1 bit rate and line control register. If the FIFO is disabled, this bit will be set when the TX holding register is full. If the FIFO is enabled, the UTXFF bit will be set when the TX FIFO is full.															
24	<b>CRXFE</b> : Codec RX FIFO empty bit. This will be set if the 16-byte codec RX FIFO is empty.															
25	<b>CTXFF</b> : Codec TX FIFO full bit. This will be set if the 16-byte codec TX FIFO is full.															
26	<b>SSIBUSY</b> : Synchronous serial interface busy bit. This bit will be set while data is being shifted in or out of the synchronous serial interface, when clear data is valid to read.															
27:28	<b>BOOTBIT0–1</b> : These bits indicate the default (power-on reset) bus width of the ROM interface. See <i>Memory Configuration Registers</i> for more details on the ROM interface bus width. The state of these bits reflect the state of Port E[0:1] during power on reset, as shown in the table below.															
<table border="1"> <thead> <tr> <th>PE[1] (BOOTBIT1)</th> <th>PE[0] (BOOTBIT0)</th> <th>Boot option</th> </tr> </thead> <tbody> <tr> <td>0</td> <td>0</td> <td>32-bit</td> </tr> <tr> <td>0</td> <td>1</td> <td>8-bit</td> </tr> <tr> <td>1</td> <td>0</td> <td>16-bit</td> </tr> <tr> <td>1</td> <td>1</td> <td>Reserved</td> </tr> </tbody> </table>		PE[1] (BOOTBIT1)	PE[0] (BOOTBIT0)	Boot option	0	0	32-bit	0	1	8-bit	1	0	16-bit	1	1	Reserved
PE[1] (BOOTBIT1)	PE[0] (BOOTBIT0)	Boot option														
0	0	32-bit														
0	1	8-bit														
1	0	16-bit														
1	1	Reserved														
29	<b>ID</b> : Will always read '1' for the EP7212 device.															
30:31	<b>VERID</b> : Version ID bits. These 2 bits determine the version id for the EP7212. Will read '10' for the initial version.															

**Table 32. SYSFLG (cont.)**

### 5.2.5 SYSFLG2 System Status Register 2

ADDRESS: 0x8000.1140

23	22	21:12	11	10:7	6
UTXFF2	URXFE2	Reserved	UBUSY2	Reserved	CKMODE
5	4	3	2	1	0
SS2TXUF	SS2TXFF	SS2RXFE	RESFRM	RESVAL	SS2RXOF

This register is an extension of SYSFLG1, containing status bits for backward compatibility with CL-PS7111. The bits of the second system status register are defined in [Table 33](#).

Bit	Description
0	<b>SS2RXOF</b> : Master / slave SSI2 RX FIFO overflow. This bit is set when a write is attempted to a full RX FIFO (i.e., when RX is still receiving data and the FIFO is full). This can be cleared in one of two ways: 1. Empty the FIFO (remove data from FIFO) and then write to SRXEOF location. 2. Disable the RX (affects of disabling the RX will not take place until a full SSI2 clock cycle after it is disabled)
1	<b>RESVAL</b> : Master / slave SSI2 RX FIFO residual byte present, cleared by popping the residual byte into the SSI2 RX FIFO or by a new RX frame sync pulse.
2	<b>RESFRM</b> : Master / slave SSI2 RX FIFO residual byte present, cleared only by a new RX frame sync pulse.
3	<b>SS2RXFE</b> : Master / slave SSI2 RX FIFO empty bit. This will be set if the 16 x 16 RX FIFO is empty.
4	<b>SS2TXFF</b> : Master / slave SSI2 TX FIFO full bit. This will be set if the 16 x 16 TX FIFO is full. This will get cleared when data is removed from the FIFO or the EP7212 is reset.
5	<b>SS2TXUF</b> : Master / slave SSI2 TX FIFO Underflow bit. This will be set if there is attempt to transmit when TX FIFO is empty. This will be cleared when FIFO gets loaded with data.
6	<b>CKMODE</b> : This bit reflects the status of the CLKSEL (PE[2]) input, latched during nPOR. When low, the PLL is running and the chip is operating in 18.432–73.728 MHz mode. When high the chip is operating from an external 13 MHz clock.
11	<b>UBUSY2</b> : UART2 transmitter busy. This bit is set while UART2 is busy transmitting data; it is guaranteed to remain set until the complete byte has been sent, including all stop bits.
22	<b>URXFE2</b> : UART2 receiver FIFO empty. The meaning of this bit depends on the state of the UFI-FOEN bit in the UART2 bit rate and line control register. If the FIFO is disabled, this bit will be set when the RX holding register contains is empty. If the FIFO is enabled, the URXFE bit will be set when the RX FIFO is empty.
23	<b>UTXFF2</b> : UART2 transmit FIFO full. The meaning of this bit depends on the state of the UFI-FOEN bit in the UART2 bit rate and line control register. If the FIFO is disabled, this bit will be set when the TX holding register is full. If the FIFO is enabled, the UTXFF bit will be set when the TX FIFO is full.

**Table 33. SYSFLG2**

## 5.3 Interrupt Registers

### 5.3.1 INTSR1 Interrupt Status Register 1

ADDRESS: 0x8000.0240

15	14	13	12	11	10	9	8
SSEOTI	UMSINT	URXINT1	UTXINT1	TINT	RTCMI	TC2OI	TC1OI
7	6	5	4	3	2	1	0
EINT3	EINT2	EINT1	CSINT	MCINT	WEINT	BLINT	EXTFIQ

The interrupt status register is a 32-bit read only register. The interrupt status register reflects the current state of the first 16 interrupt sources within the EP7212. Each bit is set if the appropriate interrupt is active. The interrupt assignment is given in [Table 34](#).

Bit	Description
0	<b>EXTFIQ:</b> External fast interrupt. This interrupt will be active if the nEXTFIQ input pin is forced low and is mapped to the FIQ input on the ARM720T processor.
1	<b>BLINT:</b> Battery low interrupt. This interrupt will be active if no external supply is present (nEXTPWR is high) and the battery OK input pin BATOK is forced low. This interrupt is de-glitched with a 16 kHz clock, so it will only generate an interrupt if it is active for longer than 125 $\mu$ sec. It is mapped to the FIQ input on the ARM720T processor and is cleared by writing to the BLEOI location. <b>NOTE:</b> BLINT is disabled during the Standby State.
2	<b>WEINT:</b> Tick Watch dog expired interrupt. This interrupt will become active on a rising edge of the periodic 64 Hz tick interrupt clock if the tick interrupt is still active (i.e., if a tick interrupt has not been serviced for a complete tick period). It is mapped to the FIQ input on the ARM720T processor and the TEOI location. <b>NOTE:</b> WEINT is disabled during the Standby State. Watch dog timer tick rate is 64 Hz (in 13 MHz and 73.728–18.432 MHz modes). Watchdog timer is turned off during the Standby State.
3	<b>MCINT:</b> Media changed interrupt. This interrupt will be active after a rising edge on the nMEDCHG input pin has been detected, This input is de-glitched with a 16 kHz clock so it will only generate an interrupt if it is active for longer than 125 $\mu$ sec. It is mapped to the FIQ input on the ARM7TDMI processor and is cleared by writing to the MCEOI location. On power-up, the Media change pin (nMEDCHG) is used as an input to force the processor to either boot from the internal Boot ROM, or from external memory. After power-up, the pin can be used as a general purpose FIQ interrupt pin.
4	<b>CSINT:</b> Codec sound interrupt, generated when the data FIFO has reached half full or empty (depending on the interface direction). It is cleared by writing to the COEOI location.
5	<b>EINT1:</b> External interrupt input 1. This interrupt will be active if the nEINT1 input is active (low). It is cleared by returning nEINT1 to the passive (high) state.
6	<b>EINT2:</b> External interrupt input 2. This interrupt will be active if the nEINT2 input is active (low). It is cleared by returning nEINT2 to the passive (high) state.
7	<b>EINT3:</b> External interrupt input 3. This interrupt will be active if the EINT3 input is active (high). It is cleared by returning EINT3 to the passive (low) state.
8	<b>TC1OI:</b> TC1 under flow interrupt. This interrupt becomes active on the next falling edge of the timer counter 1 clock after the timer counter has under flowed (reached zero). It is cleared by writing to the TC1EOI location.

Table 34. INTSR1

Bit	Description
9	<b>TC2OI:</b> TC2 under flow interrupt. This interrupt becomes active on the next falling edge of the timer counter 2 clock after the timer counter has under flowed (reached zero). It is cleared by writing to the TC2EOI location.
10	<b>RTCMI:</b> RTC compare match interrupt. This interrupt becomes active on the next rising edge of the 1 Hz Real Time Clock (one second later) after the 32-bit time written to the Real Time Clock match register exactly matches the current time in the RTC. It is cleared by writing to the RTCEOI location.
11	<b>TINT:</b> 64 Hz tick interrupt. This interrupt becomes active on every rising edge of the internal 64 Hz clock signal. This 64 Hz clock is derived from the 15-stage ripple counter that divides the 32.768 kHz oscillator input down to 1 Hz for the Real Time Clock. This interrupt is cleared by writing to the TEOI location. <b>NOTE:</b> TINT is disabled / turned off during the Standby State.
12	<b>UTXINT1:</b> Internal UART1 transmit FIFO half-empty interrupt. The function of this interrupt source depends on whether the UART1 FIFO is enabled. If the FIFO is disabled (FIFOEN bit is clear in the UART1 bit rate and line control register), this interrupt will be active when there is no data in the UART1 TX data holding register and be cleared by writing to the UART1 data register. If the FIFO is enabled this interrupt will be active when the UART1 TX FIFO is half or more empty, and is cleared by filling the FIFO to at least half full.
13	<b>URXINT1:</b> Internal UART1 receive FIFO half full interrupt. The function of this interrupt source depends on whether the UART1 FIFO is enabled. If the FIFO is disabled this interrupt will be active when there is valid RX data in the UART1 RX data holding register and be cleared by reading this data. If the FIFO is enabled this interrupt will be active when the UART1 RX FIFO is half or more full or if the FIFO is non empty and no more characters have been received for a three character time out period. It is cleared by reading all the data from the RX FIFO.
14	<b>UMSINT:</b> Internal UART1 modem status changed interrupt. This interrupt will be active if either of the two modem status lines (CTS or DSR) change state. It is cleared by writing to the UMSEOI location.
15	<b>SSEOTI:</b> Synchronous serial interface end of transfer interrupt. This interrupt will be active after a complete data transfer to and from the external ADC has been completed. It is cleared by reading the ADC data from the SYNCIO register.

**Table 34. INTSR1 (cont.)**

### 5.3.2 INTMR1 Interrupt Mask Register 1

ADDRESS: 0x8000.0280

15	14	13	12	11	10	9	8
SSEOTI	UMSINT	URXINT	UTXINT	TINT	RTCMI	TC2OI	TC1OI
7	6	5	4	3	2	1	0
EINT3	EINT2	EINT1	CSINT	MCINT	WEINT	BLINT	EXTFIQ

This interrupt mask register is a 32-bit read / write register, which is used to selectively enable any of the first 16 interrupt sources within the EP7212. The four shaded interrupts all generate a fast interrupt request to the ARM720T processor (FIQ), this will cause a jump to processor virtual address 0000.0001C. All other interrupts will generate a standard interrupt request (IRQ), this will cause a jump to processor virtual address 0000.00018. Setting the appropriate bit in this register enables the corresponding interrupt. All bits are cleared by a system reset. Please refer to *INTSR1 Interrupt Status Register 1* for individual bit details.

### 5.3.3 INTSR2 Interrupt Status Register 2

ADDRESS: 0x8000.1240

15:14	13	12	11:3	2	1	0
Reserved	URXINT2	UTXINT2	Reserved	SS2TX	SS2RX	KBDINT

This register is an extension of INTSR1, containing status bits for backward compatibility with CL-PS7111. The interrupt status register also reflects the current state of the new interrupt sources within the EP7212. Each bit is set if the appropriate interrupt is active. The interrupt assignment is given in [Table 35](#).

Bit	Description
0	<p><b>KBDINT:</b> Keyboard interrupt. This interrupt is generated whenever a key is pressed, from the logical OR of the first 6 or all 8 of the Port A inputs (depending on the state of the KBD6 bit in the SYSCON2 register. The interrupt request is latched and can be de-asserted by writing to the KBDEOI location.</p> <p><b>NOTE:</b> KBDINT is not deglitched.</p>
1	<p><b>SS2RX:</b> Synchronous serial interface 2 receives FIFO half or greater full interrupt. This is generated when RX FIFO contains 8 or more half-words. This interrupt is cleared only when the RX FIFO is emptied or one SSI2 clock after RX is disabled.</p>
2	<p><b>SS2TX:</b> Synchronous serial interface 2 transmit FIFO less than half empty interrupt. This is generated when TX FIFO contains fewer than 8 byte pairs. This interrupt gets cleared by loading the FIFO with more data or disabling the TX. One synchronization clock required when disabling the TX side before it takes effect.</p>
12	<p><b>UTXINT2:</b> UART2 transmit FIFO half empty interrupt. The function of this interrupt source depends on whether the UART2 FIFO is enabled. If the FIFO is disabled (FIFOEN bit is clear in the UART2 bit rate and line control register), this interrupt will be active when there is no data in the UART2 TX data holding register and be cleared by writing to the UART2 data register. If the FIFO is enabled, this interrupt will be active when the UART2 TX FIFO is half or more empty and is cleared by filling the FIFO to at least half full.</p>
13	<p><b>URXINT2:</b> UART2 receive FIFO half full interrupt. The function of this interrupt source depends on whether the UART2 FIFO is enabled. If the FIFO is disabled, this interrupt will be active when there is valid RX data in the UART2 RX data holding register and be cleared by reading this data. If the FIFO is enabled, this interrupt will be active when the UART2 RX FIFO is half or more full or if the FIFO is non-empty, and no more characters have been received for a three-character time-out period, t is cleared by reading all the data from the RX FIFO.</p>

Table 35. INSTR2

### 5.3.4 INTMR2 Interrupt Mask Register 2

ADDRESS: 0x8000.1280

15:14	13	12	11:3	2	1	0
Reserved	URXINT2	UTXINT2	Reserved	SS2TX	SS2RX	KBDINT

This register is an extension of INTMR1, containing interrupt mask bits for the backward compatibility with the CL-PS7111. Please refer to INTSR2 for individual bit details.

### 5.3.5 INTSR3 Interrupt Status Register 3

ADDRESS: 0x8000.2240

7:1	0
Reserved	DAIINT

This register is an extension of INTSR1 and INTSR2 containing status bits for the new features of the EP7212. Each bit is set if the appropriate interrupt is active. The interrupt assignment is given in [Table 36](#).

Bit	Description
0	<b>DAIINT:</b> DAI interface interrupt. The cause must be determined by reading the DAI status register. It is mapped to the FIQ interrupt on the ARM720T processor

**Table 36. INTSR3**

### 5.3.6 INTMR3 Interrupt Mask Register 3

ADDRESS: 0x8000.2280

7:1	0
Reserved	DAIINT

This register is an extension of INTMR1 and INTMR2, containing interrupt mask bits for the new features of the EP7212. Please refer to INTSR3 for individual bit details.

## 5.4 Memory Configuration Registers

### 5.4.1 MEMCFG1 Memory Configuration Register 1

ADDRESS: 0x8000.0180

31:24	23:16	15:8	7:0
nCS[3] configuration	nCS[2] configuration	nCS[1] configuration	nCS[0] configuration

Expansion and ROM space is selected by one of eight chip selects. One of the chip selects (nCS[6]) is used internally for the on-chip SRAM, and the configuration is hardwired for 32-bit-wide, minimum-wait-state operation. nCS[7] is used for the on-chip Boot ROM and the configuration field is hardwired for 8-bit-wide, minimum-wait-state operation. Data written to the configuration fields for either nCS[6] or nCS7 will be ignored. Two of the chip selects (nCS[4:5]) can be used to access two CL-PS6700 PC CARD controller devices, and when either of these interfaces is enabled, the configuration field for the appropriate chip select in the MEMCFG2 register is ignored. When the PC CARD1 or 2 control bit in the SYSCON2 register is disabled, then nCS[4] and nCS[5] are active as normal and can be programmed using the relevant fields of MEMCFG2, as for the other four chip selects. All of the six external chip selects are active for 256 Mbytes and the timing and bus transfer width can be programmed individually. This is accomplished by programming the six-byte-wide fields contained in two 32-bit registers, MEMCFG1 and MEMCFG2. All bits in these registers are cleared by a system reset (except for the nCS[6] and nCS[7] configurations).

The Memory Configuration Register 1 is a 32-bit read / write register which sets the configuration of the four expansion and ROM selects nCS[0:3]. Each select is configured with a 1-byte field starting with expansion select 0.

### 5.4.2 MEMCFG2 Memory Configuration Register 2

ADDRESS: 0x8000.01C0

31:24	23:16	15:8	7:0
(Boot ROM)	(Local SRAM)	nCS[5] configuration	nCS[4] configuration
7	6	5:2	1:0
CLKENB	SQAEN	Wait States Field	Bus width

The Memory Configuration Register 2 is a 32-bit read / write register which sets the configuration of the two expansion and ROM selects nCS[4:5]. Each select is configured with a 1-byte field starting with expansion select 4.

Each of the six non-reserved byte fields for chip select configuration in the memory configuration registers are identical and define the number of wait states, the bus width, enable EXPCLK output during accesses and enable sequential mode access. This byte field is defined below. This arrangement applies to nCS[0:3], and nCS[4:5] when the PC CARD enable bits in the SYSCON2 register are not set. The state of these bits is ignored for the Boot ROM and local SRAM fields in the MEMCFG2 register.

[Table 37](#) defines the bus width field. Note that the effect of this field is dependent on the two BOOTBIT bits that can be read in the SYSFLG1 register. All bits in the memory configuration register are cleared by a system reset, and the state of the BOOTBIT bits are determined by Port E bits 0 and 1 on the EP7212 during power-on reset. The state of PE[1] and PE[0] determine whether the EP7212 is going to boot from either 32-bit-wide, 16-bit-wide or 8-bit-wide ROMs.

[Table 38](#) shows the values for the wait states for random and sequential wait states at 13 and 18 MHz bus rates. At 36 MHz bus rate, the encoding becomes more complex. [Table 39](#) preserves compatibility with the previous devices, while allowing the previously unused bit combinations to specify more variations of random and sequential wait states.

Bus Width Field	BOOTBIT1	BOOTBIT0	Expansion Transfer Mode	Port E bits 1,0 during NPOR reset
00	0	0	32-bit wide bus access	Low, Low
01	0	0	16-bit wide bus access	Low, Low
10	0	0	8-bit wide bus access	Low, Low
11	0	0	Reserved	Low, Low
00	0	1	8-bit wide bus access	Low, High
01	0	1	Reserved	Low, High
10	0	1	32-bit wide bus access	Low, High
11	0	1	16-bit wide bus access	Low, High
00	1	0	16-bit wide bus access	High, Low
01	1	0	32-bit wide bus access	High, Low
10	1	0	Reserved	High, Low
11	1	0	8-bit wide bus access	High, Low

**Table 37. Values of the Bus Width Field**

Value	No. of Wait States Random	No. of Wait States Sequential
00	4	3
01	3	2
10	2	1
11	1	0

**Table 38. Values of the Wait State Field at 13 MHz and 18 MHz**

Bit 3	Bit 2	Bit 1	Bit 0	Wait States Random	Wait States Sequential
0	0	0	0	8	3
0	0	0	1	7	3
0	0	1	0	6	3
0	0	1	1	5	3
0	1	0	0	4	2
0	1	0	1	3	2
0	1	1	0	2	2
0	1	1	1	1	2
1	0	0	0	8	1
1	0	0	1	7	1
1	0	1	0	6	1
1	0	1	1	5	1
1	1	0	0	4	0
1	1	0	1	3	0
1	1	1	0	2	0
1	1	1	1	1	0

**Table 39. Values of the Wait State Field at 36 MHz**

Bit	Description
6	<b>SQAEN:</b> Sequential access enable. Setting this bit will enable sequential accesses that are on a quad word boundary to take advantage of faster access times from devices that support page mode. The sequential access will be faulted after four words (to allow video refresh cycles to occur), even if the access is part of a longer sequential access. In addition, when this bit is not set, non-sequential accesses will have a single idle cycle inserted at least every four cycles so that the chip select is de-asserted periodically between accesses for easier debug.
7	<b>CLKENB:</b> Expansion clock enable. Setting this bit enables the EXPCLK to be active during accesses to the selected expansion device. This will provide a timing reference for devices that need to extend bus cycles using the EXPRDY input. Back-to-back (but not necessarily page mode) accesses will result in a continuous clock. This bit will only affect EXPCLK when the PLL is being used (i.e., in 73.728–18.432 MHz mode). When operating in 13 MHz mode, the EXPCLK pin is an input, so it is not affected by this register bit. To save power internally, it should always be set to zero when operating in 13 MHz mode.

**Table 40. MEMCFG**

See the *AC Electrical Specification* section for more detail on bus timing.

The memory area decoded by CS[6] is reserved for the on-chip SRAM, hence this does not require a configuration field in MEMCFG2. It is automatically set up for 32-bit-wide, no-wait-state accesses. For the Boot ROM, it is automatically set up for 8-bit, no wait state accesses.

Chip selects nCS[4] and nCS[5] are used to select two CL-PS6700 PC CARD controller devices. These have a multiplexed 16-bit wide address / data interface, and the configuration bytes in the MEMCFG2 register have no meaning when these interfaces are enabled.

## 5.5 Timer / Counter Registers

### 5.5.1 TC1D Timer Counter 1 Data Register

ADDRESS: 0x8000.0300

The timer counter 1 data register is a 16-bit read / write register which sets and reads data to TC1. Any value written will be decremented on the next rising edge of the clock.

### 5.5.2 TC2D Timer Counter 2 Data Register

ADDRESS: 0x8000.0340

The timer counter 2 data register is a 16-bit read / write register which sets and reads data to TC2. Any value written will be decremented on the next rising edge of the clock.

### 5.5.3 RTCDR Real Time Clock Data Register

ADDRESS: 0x8000.0380

The Real Time Clock data register is a 32-bit read / write register, which sets and reads the binary time in the RTC. Any value written will be incremented on the next rising edge of the 1 Hz clock. This register is reset only by nPOR.

### 5.5.4 RTCMR Real Time Clock Match Register

ADDRESS: 0x8000.03C0

The Real Time Clock match register is a 32-bit read / write register, which sets and reads the binary match time to RTC. Any value written will be compared to the current binary time in the RTC, if they match it will assert the RTCMI interrupt source. This register is reset only by nPOR.

## 5.6 LEDFLSH Register

ADDRESS: 0x8000.22C0

<b>6</b>	<b>5:2</b>	<b>1:0</b>
Enable	Duty ratio	Flash rate

The output is enabled whenever LEDFLSH[6] = 1. When enabled, PDDDR[0] needs to be configured as an output pin and the bit cleared to '0' (See *PDDDR Port D Data Direction Register*). When the LED Flasher is disabled, the pin defaults to being used as Port D bit 0. Thus, this will ensure that the LED will be off when disabled.

The flash rate is determined by the LEDFLSH[1:0] bits, in the following way:

LEDFLSH[1:0]	Flash Period (sec)
00	1
01	2
10	3
11	4

**Table 41. LED Flash Rates**

LEDFLSH[5:2]	Duty Ratio (time on: time off)	LEDFLSH[5:2]	Duty Ratio (time on: time off)
0000	01:15	1000	09:07
0001	02:14	1001	10:06
0010	03:13	1010	11:05
0011	04:12	1011	12:04
0100	05:11	1100	13:03
0101	06:10	1101	14:02
0110	07:09	1110	15:01
0111	08:08	1111	16:00 (continually on)

**Table 42. LED Duty Ratio**

## 5.7 PMPCON Pump Control Register

ADDRESS: 0x8000.0400

11:8	7:4	3:0
Drive 1 pump ratio	Drive 0 from AC source ratio	Drive 0 from battery ratio

The Pulse Width Modulator (PWM) pump control register is a 16-bit read / write register which sets and controls the variable mark space ratio drives for the two PWMs. All bits in this register are cleared by a system reset. (The top four bits are unused. They should be written as zeroes, and will read as undefined).

Bit	Description
0:3	<b>Drive 0 from battery:</b> This 4-bit field controls the “on” time for the Drive 0 PWM pump while the system is powered from batteries. Setting these bits to 0 disables this pump, while setting these bits to 1 allows the pump to be driven in a 1:16 duty ratio, 2 in a 2:16 duty ratio etc. up to a 15:16 duty ratio. An 8:16 duty ratio results in a square wave of 96 kHz when operating with an 18.432 MHz master clock, or 101.6 kHz when operating from the 13 MHz source.
4:7	<b>Drive 0 from AC:</b> This 4-bit field controls the “on” time for the Drive 0 DC to DC pump, while the system is powered from a non-battery type power source. Setting these bits to 0 disables this pump, setting these bits to 1 allows the pump to be driven in a 1:16 duty ratio, 2 in a 2:16 duty ratio, etc. up to a 15:16 duty ratio. An 8:16 duty ratio results in a square wave of 96 kHz when operating with an 18.432 MHz master clock, or 101.6 kHz when operating from the 13 MHz source. <b>NOTE:</b> The EP7212 monitors the power supply input pins (i.e., BATOK and NEXTPWR) to determine which of the above fields to use.
8:11	<b>Drive 1 pump ratio:</b> This 4-bit field controls the “on” time for the drive1 PWM pump. Setting these bits to 0 disables this pump, while setting these bits to 1 allows the pump to be driven in a 1:16 duty ratio, 2 in a 2:16 duty ratio, etc. up to a 15:16 duty ratio. An 8:16 duty ratio results in a square wave of 96 kHz when operating with an 18.432 MHz master clock, or 101.6 kHz when operating from the 13 MHz source.

**Table 43. PMPCON**

The state of the output drive pins is latched during power on reset, this latched value is used to determine the polarity of the drive output. The sense of the PWM control lines is summarized in [Table 44](#).

Initial State of Drive 0 or Drive 1 During Power on Reset	Sense of Drive 0 or Drive 1	Polarity of Bias Voltage
Low	Active high	+ve
High	Active low	-ve

**Table 44. Sense of PWM control lines**

External input pins that would normally be connected to the output from comparators monitoring the PWM output are also used to enable these clocks. These are the FB[0:1] pins. When FB[0] is high, the PWM is disabled. The same applies to FB[1]. They are read upon power-up.

**NOTE:** To maximize power savings, the drive ratio fields should be used to disable the PWMs, instead of the FB pins. The clocks that source the PWMs are disabled when the drive ratio fields are zeroed.

## 5.8 CODR — The CODEC Interface Data Register

ADDRESS: 0x8000.0440

The CODR register is an 8-bit read / write register, to be used with the codec interface. This is selected by the appropriate setting of bit 0 (SERSEL) of the SYSCON2 register. Data written to or read from this register is pushed or popped onto the appropriate 16-byte FIFO buffer. Data from this buffer is then serialized and sent to or received from the codec sound device. When the codec is enabled, the codec interrupt CSINT is generated repetitively at 1/8th of the byte transfer rate and the state of the FIFOs can be read in the system flags register. The net data transfer rate to / from the codec device is 8 kBytes/s, giving an interrupt rate of 1 kHz.

## 5.9 UART Registers

### 5.9.1 UARTDR1–2, UART1–2 Data Registers

ADDRESS: 0x8000.0480 and 0x8000.1480

10	9	8	7:0
OVERR	PARERR	FRMERR	RX data

The UARTDR registers are 11-bit read and 8-bit write registers for all data transfers to or from the internal UARTs 1 and 2.

Data written to these registers is pushed onto the 16-byte data TX holding FIFO if the FIFO is enabled. If not it is stored in a one byte holding register. This write will initiate transmission from the UART.

The UART data read registers are made up of the 8-bit data byte received from the UART together with three bits of error status. If the FIFO is enabled, data read from this register is popped from the 16 byte data RX FIFO. If the FIFO is not enabled, it is read from a one byte buffer register containing the last byte received by the UART. If it is enabled, data received and error status is automatically pushed onto the RX FIFO. The RX FIFO is 10-bits wide by 16 deep.

**NOTE:** These registers should be accessed as words.

Bit	Description
8	<b>FRMERR:</b> UART framing error. This bit is set if the UART detected a framing error while receiving the associated data byte. Framing errors are caused by non-matching word lengths or bit rates.
9	<b>PARERR:</b> UART parity error. This bit is set if the UART detected a parity error while receiving the data byte.
10	<b>OVERR:</b> UART over-run error. This bit is set if more data is received by the UART and the FIFO is full. The overrun error bit is not associated with any single character and so is not stored in the FIFO. If this bit is set, the entire contents of the FIFO is invalid and should be cleared. This error bit is cleared by reading the UARTDR register.

**Table 45. UARTDR1-2 UART1-2**

### 5.9.2 UBRLCR1-2 UART1-2 Bit Rate and Line Control Registers

ADDRESS: 0x8000.04C0 and 0x8000.14C0

31:19	18:17	16	15	14	13	12	11:0
	WRDLEN	FIFOEN	XSTOP	EVENPRT	PRTEN	BREAK	Bit rate divisor

The bit rate divisor and line control register is a 19-bit read / write register. Writing to these registers sets the bit rate and mode of operation for the internal UARTs.

Bit	Description																																																						
0:11	<p><b>Bit rate divisor:</b> This 12-bit field sets the bit rate. If the system is operating from the PLL clock, then the bit rate divisor is fed by a clock frequency of 3.6864 MHz, which is then further divided internally by 16 to give the bit rate. The formula to give the divisor value for any bit rate when operating from the PLL clock is: <math>\text{Divisor} = 230400 / (\text{bit rate divisor} + 1)</math>. A value of zero in this field is illegal when running from the PLL clock. The tables below show some example bit rates with the corresponding divisor value. In 13 MHz mode, the clock frequency fed to the UART is 1.8571 MHz. In this mode, zero is a legal divisor value, and will generate the maximum possible bit rate. The tables below show the bit rates available for both 18.432 MHz and 13 MHz operation.</p> <table border="1" style="display: inline-table; margin-right: 20px;"> <thead> <tr> <th>Divisor Value</th> <th>Bit Rate Running From the PLL Clock</th> </tr> </thead> <tbody> <tr><td>0</td><td>—</td></tr> <tr><td>1</td><td>115200</td></tr> <tr><td>2</td><td>76800</td></tr> <tr><td>3</td><td>57600</td></tr> <tr><td>5</td><td>38400</td></tr> <tr><td>11</td><td>19200</td></tr> <tr><td>15</td><td>14400</td></tr> <tr><td>23</td><td>9600</td></tr> <tr><td>95</td><td>2400</td></tr> <tr><td>191</td><td>1200</td></tr> <tr><td>2094</td><td>110</td></tr> </tbody> </table> <table border="1" style="display: inline-table;"> <thead> <tr> <th>Divisor Value</th> <th>Bit Rate at 13 Mhz</th> <th>Error on 13 MHz Value</th> </tr> </thead> <tbody> <tr><td>0</td><td>116071</td><td>0.75%</td></tr> <tr><td>1</td><td>58036</td><td>0.75%</td></tr> <tr><td>2</td><td>38690</td><td>0.75%</td></tr> <tr><td>5</td><td>19345</td><td>0.75%</td></tr> <tr><td>7</td><td>14509</td><td>0.75%</td></tr> <tr><td>11</td><td>9673</td><td>0.75%</td></tr> <tr><td>47</td><td>2418</td><td>0.42%</td></tr> <tr><td>96</td><td>1196</td><td>0.28%</td></tr> <tr><td>1054</td><td>110.02</td><td>0.18%</td></tr> </tbody> </table>	Divisor Value	Bit Rate Running From the PLL Clock	0	—	1	115200	2	76800	3	57600	5	38400	11	19200	15	14400	23	9600	95	2400	191	1200	2094	110	Divisor Value	Bit Rate at 13 Mhz	Error on 13 MHz Value	0	116071	0.75%	1	58036	0.75%	2	38690	0.75%	5	19345	0.75%	7	14509	0.75%	11	9673	0.75%	47	2418	0.42%	96	1196	0.28%	1054	110.02	0.18%
Divisor Value	Bit Rate Running From the PLL Clock																																																						
0	—																																																						
1	115200																																																						
2	76800																																																						
3	57600																																																						
5	38400																																																						
11	19200																																																						
15	14400																																																						
23	9600																																																						
95	2400																																																						
191	1200																																																						
2094	110																																																						
Divisor Value	Bit Rate at 13 Mhz	Error on 13 MHz Value																																																					
0	116071	0.75%																																																					
1	58036	0.75%																																																					
2	38690	0.75%																																																					
5	19345	0.75%																																																					
7	14509	0.75%																																																					
11	9673	0.75%																																																					
47	2418	0.42%																																																					
96	1196	0.28%																																																					
1054	110.02	0.18%																																																					
12	<b>BREAK:</b> Setting this bit will drive the TX output active (high) to generate a break.																																																						
13	<b>PRTEN:</b> Parity enable bit. Setting this bit enables parity detection and generation																																																						
14	<b>EVENPRT:</b> Even parity bit. Setting this bit sets parity generation and checking to even parity, clearing it sets odd parity. This bit has no effect if the PRTEN bit is clear.																																																						
15	<b>XSTOP:</b> Extra stop bit. Setting this bit will cause the UART to transmit two stop bits after each data byte, while clearing it will transmit one stop bit after each data byte.																																																						
16	<b>FIFOEN:</b> Set to enable FIFO buffering of RX and TX data. Clear to disable the FIFO (i.e., set its depth to one byte).																																																						
17:18	<p><b>WRDLEN:</b> This two bit field selects the word length according to the table below.</p> <table border="1" style="margin-left: auto; margin-right: auto;"> <thead> <tr> <th>WRDLEN</th> <th>Word Length</th> </tr> </thead> <tbody> <tr><td>00</td><td>5 bits</td></tr> <tr><td>01</td><td>6 bits</td></tr> <tr><td>10</td><td>7 bits</td></tr> <tr><td>11</td><td>8 bits</td></tr> </tbody> </table>	WRDLEN	Word Length	00	5 bits	01	6 bits	10	7 bits	11	8 bits																																												
WRDLEN	Word Length																																																						
00	5 bits																																																						
01	6 bits																																																						
10	7 bits																																																						
11	8 bits																																																						

Table 46. UBRLCR1-2 UART1-2

## 5.10 LCD Registers

### 5.10.1 LCDCON — The LCD Control Register

ADDRESS: 0x8000.02C0

31	30	29:25	24:19	18:13	12:0
GSMD	GSEN	AC prescale	Pixel prescale	Line length	Video buffer size

The LCD control register is a 32-bit read / write register that controls the size of the LCD screen and the operating mode of the LCD controller. Refer to the system description of the LCD controller for more information on video buffer mapping.

The LCDCON register should only be reprogrammed when the LCD controller is disabled.

Bit	Description
0:12	<p><b>Video buffer size:</b> The video buffer size field is a 13-bit field that sets the total number of bits x 128 (quad words) in the video display buffer. This is calculated from the formula:</p> $\text{Video buffer size} = (\text{Total bits in video buffer} / 128) - 1$ <p>i.e., for a 640 x 240 LCD and 4 bits-per-pixel, the size of the video buffer is equal to 614400 bits.</p> $\text{Video buffer} = 640 \times 240 \times 4 = 614400 \text{ bits}$ $\text{Video buffer size field} = (614400 / 128) - 1 = 4799 \text{ or } 0x12BF \text{ hex.}$ <p>The minimum value allowed is 3 for this bit field.</p>
13:18	<p><b>Line length:</b> The line length field is a 6-bit field that sets the number of pixels in one complete line. This field is calculated from the formula:</p> $\text{line length} = (\text{Number of pixels in line} / 16) - 1$ <p>i.e., for 640 x 240 LCD Line length = <math>(640 / 16) - 1 = 39</math> or 0x27 hex.</p> <p>The minimum value that can be programmed into this register is a 1 (i.e., 0 is not a legal value).</p>

**Table 47. LCDCON**

Bit	Description
19:24	<p><b>Pixel prescale:</b> The pixel prescale field is a 6-bit field that sets the pixel rate prescale. The pixel rate is always derived from a 36.864 MHz clock when in PLL mode, and is calculated from the formula:  <math display="block">\text{Pixel rate (MHz)} = 36.864 / (\text{Pixel prescale} + 1)</math>                     When the EP7212 is operating at 13 MHz, pixel rate is given by the formula:  <math display="block">\text{Pixel rate (MHz)} = 13 / (\text{Pixel prescale} + 1)</math>                     The pixel prescale value can be expressed in terms of the LCD size by the formula:                      When the EP7212 is operating @ 18.432 MHz:  <math display="block">\text{Pixel prescale} = (36864000 / (\text{Refresh Rate} \times \text{Total pixels in display})) - 1</math>                     When the EP7212 is operating @ 13 MHz:  <math display="block">\text{Pixel prescale} = (13000000 / (\text{Refresh Rate} \times \text{Total pixels in display})) - 1</math>                     Refresh Rate is the screen refresh frequency (70 Hz to avoid flicker)                      The value should be rounded down to the nearest whole number and zero is illegal and will result in no pixel clock.  <b>EXAMPLE:</b> For a system being operated in the 18.432–73.728 MHz mode, with a 640 x 240 screen size, and 70 Hz screen refresh rate desired, the LCD Pixel prescale equals <math>36.864E6 / (70 \times 640 \times 240) - 1 = 2.428</math>                      Rounding 2.428 down to the nearest whole number equals 2.                      This gives an actual pixel rate of <math>36.864E6 / (2+1) = 12.288 \text{ MHz}</math>, which gives an actual refresh frequency of <math>12.288E6 / (640 \times 240) = 80 \text{ Hz}</math>.  <b>NOTE:</b> As the CL[2] low pulse time is doubled after every CL[1] high pulse this refresh frequency is only an approximation, the accurate formula is <math>12.288E6 / ((640 \times 240) + 120) = 79.937 \text{ Hz}</math>.</p>
25:29	<p><b>AC prescale:</b> The AC prescale field is a 5-bit number that sets the LCD AC bias frequency. This frequency is the required AC bias frequency for a given manufacturer's LCD plate. This frequency is derived from the frequency of the line clock (CL[1]). The LCD M signal will toggle after n+1 counts of the line clock (CL[1]) where n is the number programmed into the AC prescale field. This number must be chosen to match the manufacturer's recommendation. This is normally 13, but must not be exactly divisible by the number of lines in the display.</p>
30	<p><b>GSEN:</b> Grayscale enable bit. Setting this bit enables grayscale output to the LCD. When this bit is cleared, each bit in the video map directly corresponds to a pixel in the display.</p>
31	<p><b>GSMD:</b> Grayscale mode bit. Clearing this bit sets the controller to 2 bits-per-pixel (4 grayscale), setting it sets it to 4 bits-per-pixel (16 grayscale). This bit has no effect if GSEN is cleared.</p>

**Table 47. LCDCON (cont.)**

### 5.10.2 PALLSW Least Significant Word — LCD Palette Register

ADDRESS: 0x8000.0580

31:28	27:24	23:20	19:16	15:12	11:8	7:4	3:0
Grayscale value for pixel value 7	Grayscale value for pixel value 6	Grayscale value for pixel value 5	Grayscale value for pixel value 4	Grayscale value for pixel value 3	Grayscale value for pixel value 2	Grayscale value for pixel value 1	Grayscale value for pixel value 0

The least and most significant word LCD palette registers make up a 64-bit read / write register which maps the logical pixel value to a physical grayscale level. The 64-bit register is made up of 16 x 4-bit nibbles, each nibble defines the grayscale level associated with the appropriate pixel value. If the LCD controller is operating in two bits-per-pixel, only the lower 4 nibbles are valid (D[15:0] in the least significant word). Similarly, one bit-per-pixel means only the lower 2 nibbles are valid (D[7:0]) in the least significant word.

### 5.10.3 PALMSW Most Significant Word — LCD Palette Register

ADDRESS: 0x8000.0540

31:28	27:24	23:20	19:16	15:12	11:8	7:4	3:0
Grayscale value for pixel value 15	Grayscale value for pixel value 14	Grayscale value for pixel value 13	Grayscale value for pixel value 12	Grayscale value for pixel value 11	Grayscale value for pixel value 10	Grayscale value for pixel value 9	Grayscale value for pixel value 8

The pixel to grayscale level assignments and the actual physical color and pixel duty ratio for the grayscale values are shown in [Table 48](#). Note that colors 8–15 are the inverse of colors 7–0 respectively. This means that colors 7 and 8 are identical. Therefore, in reality only 15 grayscales available, not 16. The steps in the grayscale are non-linear, but have been chosen to give a close approximation to perceived linear grayscales. This is due to the eye being more sensitive to changes in gray level close to 50% gray (See *PALLSW* description).

Grayscale Value	Duty Cycle	% Pixels Lit	% Step Change
0	0	0%	11.1%
1	1/9	11.1%	8.9%
2	1/5	20.0%	6.7%
3	4/15	26.7%	6.6%
4	3/9	33.3%	6.7%
5	2/5	40.0%	5.4%
6	4/9	44.4%	5.6%
7	1/2	50.0%	0.0%
8	1/2	50.0%	5.6%
9	5/9	55.6%	5.4%
10	3/5	60.0%	6.7%
11	6/9	66.7%	6.6%
12	11/15	73.3%	6.7%
13	4/5	80.0%	8.9%
14	8/9	88.9%	11.1%
15	1	100%	

**Table 48. Grayscale Value to Color Mapping**

### 5.10.4 FBADDR LCD Frame Buffer Start Address

ADDRESS: 0x8000.1000

This register contains the start address for the LCD Frame Buffer. It is assumed that the frame buffer starts at location 0x0000000 within each chip select memory region. Therefore, the value stored within the FBADDR register is only the value of the chip select where the frame buffer is located. On reset, this will be set to 0xC. The register is 4 bits wide (bits [3:0]). This register must only be reprogrammed when the LCD is disabled (i.e., setting the LCDEN bit within SYSCON2 low).

## 5.11 SSI Register

### 5.11.1 SYNCIO Synchronous Serial ADC Interface Data Register

ADDRESS: 0x8000.0500

In the default mode, the bits in SYNCIO have the following meaning:

31:15	14	13	12:8	7:0
Reserved	TXFRMEN	SMCKEN	Frame length	ADC Configuration Byte

Whereas in extended mode, the following applies:

15	14	13	12:7	6:0
Reserved	TXFRMEN	SMCKEN	Frame length	ADC Configuration Length

ADC Configuration Extension

**NOTE:** The frame length in extended mode is 6 bits wide to allow up to 16 write bits, 1 null bit and 16 read bits (= 33 cycles).

SYNCIO is a 32-bit read / write register. The data written to the SYNCIO register configures the master only SSI. In default mode, the least significant byte is serialized and transmitted out of the synchronous serial interface1 (i.e., SS1) to configure an external ADC, MSB first. In extended mode, a variable number of bits are sent from SYNCIO[16:31] as determined by the ADC Configuration Length. The transfer clock will automatically be started at the programmed frequency and a synchronization pulse will be issued. The ADCIN pin is sampled on every positive going clock edge (or the falling clock edge, if ADCCKNSEN in SYSCON3 is set) and the result is shifted in to the SYNCIO read register.

During data transfer, the SSIBUSY bit is set high; at the end of a transfer the SSEOTI interrupt will be asserted. To clear the interrupt the SYNCIO register must be read. The data read from the SYNCIO register is the last sixteen bits shifted out of the ADC.

The length of the data frame can be programmed by writing to the SYNCIO register. This allows many different ADCs to be accommodated. The device is SPI- / Microwire-compatible (transfers are in multiples of 8 bits). However, to be compatible with some non-SPI / Microwire devices, the data written to the ADC device can be anything between 8 to 16 bits. This is user-definable per the ADC Configuration Extension section of the SYNCIO register.

Bit	Description
0:7 or 0:6	<b>ADC Configuration Byte:</b> When the ADCCON control bit in the SYSCON3 register = 0, this is the 8-bit configuration data to be sent to the ADC. When the ADCCON control bit in the SYSCON3 register = 1, this field determines the length of the ADC configuration data held in the ADC Configuration Extension field for sending to the ADC.
8:12 or 7:12	<b>Frame length:</b> The Frame Length field is the total number of shift clocks required to complete a data transfer. In default mode, MAX148/9 (and for many ADCs), this is 25 = (8 for configuration byte + 1 null bit + 16 bits result). In extended mode, AD7811/12, this is 23 = (10 for configuration byte + 3 null + 10 bits result).

**Table 49. SYNCIO**

Bit	Description
13	<b>SMCKEN:</b> Setting this bit will enable a free running sample clock at twice the programmed ADC clock frequency to be output on the SMPLCK pin.
14	<b>TXFRMEN:</b> Setting this bit will cause an ADC data transfer to be initiated. The value in the ADC configuration field will be shifted out to the ADC and depending on the frame length programmed, a number of bits will be captured from the ADC. If the SYNCIO register is written to with the TXFRMEN bit low, no ADC transfer will take place, but the Frame length and SMCKEN bits will be affected.
16:31	<b>ADC Configuration Extension:</b> When the ADCCON control bit in the SYSCON3 register = 0, this field is ignored for compatibility with the CL-PS7111. When the ADCCON control bit in the SYSCON3 register = 1, this field is the configuration data to be sent to the ADC. The ADC Configuration Extension field length is determined by the value held in the ADC Configuration Length field (SYNCIO[6:0]).

**Table 49. SYNCIO (cont.)**

## 5.12 STFCLR Clear all ‘Start Up Reason’ flags location

ADDRESS: 0x8000.05C0

A write to this location will clear all the ‘Start Up Reason’ flags in the system flags status register SYS-FLG. The ‘Start Up Reason’ flags should first read to determine the reason why the chip was started (i.e., a new battery was installed). Any value may be written to this location.

## 5.13 End Of Interrupt Locations

The ‘End of Interrupt’ locations that follow are written to after the appropriate interrupt has been serviced. The write is performed to clear the interrupt status bit, so that other interrupts can be serviced. Any value may be written to these locations.

### 5.13.1 BLEOI Battery Low End of Interrupt

ADDRESS: 0x8000.0600

A write to this location will clear the interrupt generated by a low battery (falling edge of BATOK with nEXTPWR high).

### 5.13.2 MCEOI Media Changed End of Interrupt

ADDRESS: 0x8000.0640

A write to this location will clear the interrupt generated by a falling edge of the nMEDCHG input pin.

### 5.13.3 TEOI Tick End of Interrupt Location

ADDRESS: 0x8000.0680

A write to this location will clear the current pending tick interrupt and tick watch dog interrupt.

### 5.13.4 TCIEOI TC1 End of Interrupt Location

ADDRESS: 0x8000.06C0

A write to this location will clear the under flow interrupt generated by TC1.

### ***5.13.5 TC2EOI TC2 End of Interrupt Location***

ADDRESS: 0x8000.0700

A write to this location will clear the under flow interrupt generated by TC2.

### ***5.13.6 RTCEOI RTC Match End of Interrupt***

ADDRESS: 0x8000.0740

A write to this location will clear the RTC match interrupt

### ***5.13.7 UMSEOI UART1 Modem Status Changed End of Interrupt***

ADDRESS: 0x8000.0780

A write to this location will clear the modem status changed interrupt.

### ***5.13.8 COEOI Codec End of Interrupt Location***

ADDRESS: 0x8000.07C0

A write to this location clears the sound interrupt (CSINT).

### ***5.13.9 KBDEOI Keyboard End of Interrupt Location***

ADDRESS: 0x8000.1700

A write to this location clears the KBDINT keyboard interrupt.

### ***5.13.10 SRXEOF End of Interrupt Location***

ADDRESS: 0x8000.1600

A write to this location clears the SSI2 RX FIFO overflow status bit.

## **5.14 State Control Registers**

### ***5.14.1 STDBY Enter the Standby State Location***

ADDRESS: 0x8000.0840

A write to this location will put the system into the Standby State by halting the main oscillator. A write to this location while there is an active interrupt will have no effect.

- NOTES:**
- 1) Before entering the Standby State, the LCD Controller should be disabled. The LCD controller should be enabled on exit from the Standby State.
  - 2) If the EP7212 is attempting to get into the Standby State when there is a pending interrupt request, it will not enter into the low power mode. The instruction will get executed, but the processor will ignore the command.

### ***5.14.2 HALT Enter the Idle State Location***

ADDRESS: 0x8000.0800

A write to this location will put the system into the Idle State by halting the clock to the processor until an interrupt is generated. A write to this location while there is an active interrupt will have no effect.

## 5.15 SS2 Registers

### 5.15.1 SS2DR Synchronous Serial Interface 2 Data Register

ADDRESS: 0x8000.1500

This is the 16-bit-wide data register for the full-duplex master / slave SSI2 synchronous serial interface. Writing data to this register will initiate a transfer. Writes need to be word writes and the bottom 16 bits are transferred to the TX FIFO. Reads will be 32 bits as well with the lower 16 bits containing RX data, and the upper 16-bits should be ignored. Although the interface is byte-oriented, data is written in two bytes at a time to allow higher bandwidth transfer. It is up to the software to assemble the bytes for the data stream in an appropriate manner.

All reads / writes to this register must be word reads / writes.

### 5.15.2 SS2POP Synchronous Serial Interface 2 Pop Residual Byte

ADDRESS: 0x8000.16C0

This is a write-only location which will cause the contents of the RX shift register to be popped into the RX FIFO, thus enabling a residual byte to be read. The data value written to this register is ignored. This location should be used in conjunction with the RESVAL and RESFRM bits in the SYSFLG2 register.

## 5.16 DAI Register Definitions

There are five registers within the DAI Interface, one control register, three data registers, and one status register. The control register is used to mask or unmask interrupt requests to service the DAI's FIFOs, and to select whether an on-chip or off-chip clock is used to drive the bit rate, and to enable / disable operation. The first pair of data register addresses the top of the Right Channel Transmit FIFO and the bottom of the Right Channel Receive FIFO. A read accesses the receive FIFOs, and a write the transmit FIFOs. Note that these are four physically separate FIFOs to allow full-duplex transmission. The status register contains bits which signal FIFO overrun and underrun errors and transmit and receive FIFO service requests. Each of these status conditions signal an interrupt request to the interrupt controller. The status register also flags when the transmit FIFOs are not full when the receive FIFOs are not empty.

### 5.16.1 DAIR DAI Control Register

ADDRESS: 0x8000.2000

31:24	23	22	21	20	19	18	17	16	15:0
Reserved	LBM	RCRM	RCTM	LCRM	LCTM	Reserved	ECS	DAIEN	Reserved

The DAI control register (DAIR) contains eight different bit fields that control various functions within the DAI interface.

Bit	Description
0:15	Reserved Must be set to 0x0404
7	Reserved
15	Reserved
16	<b>DAIEN:</b> DAI Interface Enable 0 — DAI operation disabled, control of the SDIN, SDOUT, SCLKLRCK, and LRCK pins given to the SSI2 / codec / DAI pin multiplexing logic to assign I/O pins 60-64 to another block. 1 — DAI operation enabled Note that by default, the SSI / CODEC have precedence over the DAI interface in regard to the use of the I/O pins. Nevertheless, when bit 3 (DAISEL) of register SYSCON3 is set to 1, then the above mentioned DAI ports are connected to I/O pins 60-64.
17	<b>ECS:</b> External Clock Select selects external MCLK when = 1.
18	Reserved Must be 0.
19	<b>LCTM:</b> Left Channel Transmit FIFO Interrupt Mask 0 — Left Channel Transmit FIFO half-full or less condition does not generate an interrupt (LCTS bit ignored). 1 — Left Channel Transmit FIFO half-full or less condition generates an interrupt (state of LCTS sent to interrupt controller).
20	<b>LCRM:</b> Left Channel Receive FIFO Interrupt Mask 0 — Left Channel Receive FIFO half-full or more condition does not generate an interrupt (LCRS bit ignored). 1 — Left Channel Receive FIFO half-full or more condition generates an interrupt (state of LCRS sent to interrupt controller).
21	<b>RCTM:</b> Right Channel Transmit FIFO Interrupt Mask 0 — Right Channel Transmit FIFO half-full or less condition does not generate an interrupt (RCTS bit ignored). 1 — Right Channel Transmit FIFO half-full or less condition generates an interrupt (state of RCTS sent to interrupt controller).
22	<b>RCRM:</b> Right Channel Receive FIFO Interrupt Mask 0 — Right Channel Receive FIFO half-full or more condition does not generate an interrupt (RCRS bit ignored). 1 — Right Channel Receive FIFO half-full or more condition generates an interrupt (state of RCRS sent to interrupt controller).
23	<b>LBM:</b> Loopback Mode 0 — Normal serial port operation enabled 1 — Output of serial shifter is connected to input of serial shifter internally and control of SDIN, SDOUT, SCLK, and LRCK pins is given to the PPC unit.
24:31	Reserved

**Table 50. DAI Control Register**

### 5.16.1.1 *DAI Enable (DAIEN)*

The DAI enable (DAIEN) bit is used to enable and disable all DAI operation.

When the DAI is disabled, all of its clocks are powered down to minimize power consumption. Note that DAIEN is the only control bit within the DAI interface that is reset to a known state. It is cleared to zero to ensure the DAI timing is disabled following a reset of the device.

When the DAI timing is enabled, SCLK begins to transition and the start of the first frame is signaled by driving the LRCK pin low. The rising and falling-edge of LRCK coincides with the rising and falling-edge of SCLK. As long as the DAIEN bit is set, the DAI interface operates continuously, transmitting and receiving 128 bit data frames. When the DAIEN bit is cleared, the DAI interface is disabled immediately, causing the current frame which is being transmitted to be terminated. Clearing DAIEN resets the DAI's interface FIFOs. However DAI data register 3, the control register and the status register are not reset. Therefore, the user must ensure these registers are properly reconfigured before re-enabling the DAI interface.

### 5.16.1.2 *DAI Interrupt Generation*

The DAI interface can generate four maskable interrupts and four non-maskable interrupts, as described in the sections below. Only one interrupt line is wired into the interrupt controller for the whole DAI interface. This interrupt is the wired OR of all eight interrupts (after masking where appropriate). The software servicing the interrupts must read the status register in the DAI to determine which source(s) caused the interrupt. It is possible to prevent any DAI sources causing an interrupt by masking the DAI interrupt in the interrupt controller register.

### 5.16.1.3 *Left Channel Transmit FIFO Interrupt Mask (LCTM)*

The Left channel sample transmit FIFO interrupt mask (LCTM) bit is used to mask or enable the left channel sample transmit FIFO service request interrupt. When LCTM = 0, the interrupt is masked and the state of the Left Channel Transmit FIFO service request (LCTS) bit within the DAI status register is ignored by the interrupt controller. When LCTM = 1, the interrupt is enabled and whenever LCTS is set (one) an interrupt request is made to the interrupt controller. Note that programming LCTM = 0 does not affect the current state of LCTS or the Left Channel Transmit FIFO logic's ability to set and clear LCTS; it only blocks the generation of the interrupt request.

### 5.16.1.4 *Left Channel Receive FIFO Interrupt Mask (LARM)*

The left channel sample receive FIFO interrupt mask (LCRM) bit is used to mask or enable the Left Channel Receive FIFO service request interrupt. When LCRM = 0, the interrupt is masked and the state of the left channel sample receive FIFO service request (LCRS) bit within the DAI status register is ignored by the interrupt controller. When LCRM = 1, the interrupt is enabled and whenever LCRS is set (one) an interrupt request is made to the interrupt controller. Note that programming LCRM = 0 does not affect the current state of LCRS or the Left Channel Receive FIFO logic's ability to set and clear LCRS, it only blocks the generation of the interrupt request.

### 5.16.1.5 *Right Channel Transmit FIFO Interrupt Mask (RCTM)*

The Right Channel Transmit FIFO interrupt mask (RCTM) bit is used to mask or enable the right channel transmit FIFO service request interrupt. When RCTM = 0, the interrupt is masked and the state of the Right Channel Transmit FIFO service request (RCTS) bit within the DAI status register is ignored by the interrupt controller. When RCTM = 1, the interrupt is enabled and whenever RCTS is set (one) an interrupt request is made to the interrupt controller. Note that programming RCTM = 0 does not affect the current state of RCTS or the Right Channel Transmit FIFO logic's ability to set and clear RCTS, for it only blocks the generation of the interrupt request.

### 5.16.1.6 Right Channel Receive FIFO Interrupt Mask (RCRM)

The Right Channel Receive FIFO interrupt mask (RCRM) bit is used to mask or enable the Right Channel Receive FIFO service request interrupt. When RCRM = 0, the interrupt is masked and the state of the Right Channel Receive FIFO service request (RCRS) bit within the DAI status register is ignored by the interrupt controller. When RCRM = 1, the interrupt is enabled, and whenever RCRS is set (one), an interrupt request is made to the interrupt controller. Note that programming RCRM = 0 does not affect the current state of RCRS or the Right Channel Receive FIFO logic's ability to set and clear RCRS, for it only blocks the generation of the interrupt request.

### 5.16.1.7 Loopback Mode (LBM)

The Loopback mode (LBM) bit is used to enable and disable the ability of the DAI's transmit and receive logic to communicate. When LBM = 0, the DAI operates normally. The transmit and receive data paths are independent and communicate via their respective pins. When LBM = 1, the output of the serial shifter (MSB) is directly connected to the input of the serial shifter (LSB) internally and control of the SDOUT, SDIN, SCLK, and LRCK pins are given to the peripheral pin control (PPC) unit.

[Table 50](#) shows the bit locations corresponding to the ten different control bit fields within the DAI control register. Note that the DAIEN bit is the only control bit which is reset to a known state to ensure the DAI is disabled following a reset of the device. The reset state of all other control bits is unknown and must be initialized before enabling the DAI. Writes to reserved bits are ignored, and reads return zeros.

### 5.16.2 DAI Data Registers

The DAI contains three data registers: DAIDR0 addresses the top entry of the Right Channel Transmit FIFO and bottom entry of the Right Channel Receive FIFO; DAIDR1 addresses the top and bottom entry of the Left Channel Transmit and Receive FIFOs, respectively; and DAIDR2 is used to perform enable and disable the DAI FIFOs.

#### 5.16.2.1 DAIDR0 DAI Data Register 0

ADDRESS: 0x8000.2040

<b>31:16</b>	<b>15:0</b>
Reserved	Bottom of Right Channel Receive FIFO
<b>Read Access</b>	
<b>31:16</b>	<b>15:0</b>
Reserved	Top of Right Channel Transmit FIFO
<b>Write Access</b>	

When DAI Data Register 0 (DAIDR0) is read, the bottom entry of the Right Channel Receive FIFO is accessed. As data is removed by the DAI's receive logic from the incoming data frame, it is placed into the top entry of the Right Channel Receive FIFO and is transferred down an entry at a time until it reaches the last empty location within the FIFO. Data is removed by reading DAIDR0, which accesses the bottom entry of the right channel FIFO. After DAIDR0 is read, the bottom entry is invalidated, and all remaining values within the FIFO automatically transfer down one location.

When DAIDR0 is written, the top-most entry of the Right Channel Transmit FIFO is accessed. After a write, data is automatically transferred down to the lowest location within the transmit FIFO which does not already contain valid data. Data is removed from the bottom of the FIFO one value at a time by the transmit logic, loaded into the correct position within the 64-bit transmit serial shifter, then serially shifted out onto the SDOOUT pin.

[Table 51](#) shows DAIDR0. Note that the Transmit and Receive Right Channel FIFOs are cleared when the device is reset, or by writing a zero to DAIEN (DAI disabled). Also, note that writes to reserved bits are ignored and reads return zeros.

Bit	Description
0:15	<b>RIGHT CHANNEL DATA:</b> Transmit / Receive Right Channel FIFO Data Read — Bottom of Right Channel Receive FIFO data Write — Top of Right Channel Transmit FIFO data
16:31	Reserved

**Table 51. DAI Data Register 0**

### 5.16.2.2 DAIDR1 DAI Data Register 1

ADDRESS: 0x8000.2080

<b>31:16</b>		<b>15:0</b>
Reserved		Bottom of Left Channel Receive FIFO
<b>Read Access</b>		
<b>31:16</b>		<b>15:0</b>
Reserved		Top of Left Channel Transmit FIFO
<b>Write Access</b>		

When DAI Data Register 1 (DAIDR1) is read, the bottom entry of the Left Channel Receive FIFO is accessed. As data is removed by the DAI's receive logic from the incoming data frame, it is placed into the top entry of the Left Channel Receive FIFO and is transferred down an entry at a time until it reaches the last empty location within the FIFO. Data is removed by reading DAIDR1, which accesses the bottom entry of the left channel FIFO. After DAIDR1 is read, the bottom entry is invalidated, and all remaining values within the FIFO automatically transfer down one location.

When DAIDR1 is written, the top-most entry of the Left Channel Transmit FIFO is accessed. After a write, data is automatically transferred down to the lowest location within the transmit FIFO which does not already contain valid data. Data is removed from the bottom of the FIFO one value at a time by the transmit logic. It is then loaded into the correct position within the 64-bit transmit serial shifter then serially shifted out onto the SDOUT pin.

[Table 52](#) shows DAIDR1. Note that the Transmit and Receive Left Channel FIFOs are cleared when the device is reset, or by writing a zero to DAIEN (DAI disabled). Also, note that writes to reserved bits are ignored and reads return zeros.

Bit	Description
0:15	<b>LEFT CHANNEL DATA:</b> Transmit / Receive Left Channel FIFO Data Read — Bottom of Left Channel Receive FIFO data Write — Top of Left Channel Transmit FIFO data
16:31	Reserved

**Table 52. DAI Data Register 1**

### 5.16.2.3 DAIDR2 DAI Data Register 2

ADDRESS: 0x8000.20C0

31:21	20:16	15	14:0
Reserved	FIFO Channel Select	FIFOEN	Reserved

DAIDR2 is a 32-bit register that utilizes 21 bits and is used to enable and disable the FIFOs for the left and right channels of the DAI data stream. The left channel FIFO is enabled by writing 0x000D.8000 and disabled by writing 0x000D.0000. The right channel FIFO is enabled by writing 0x0011.8000 and disabled by writing 0x0011.0000. After writing a value to this register, wait until the FIFO operation complete bit (FIFO) is set in the DAI status register before writing another value to this register.

Bit	Description
0:14	Reserved
15	<b>FIFOEN:</b> FIFO Transmit Bit 0 — Disable Transmit 1 — Enable Transmit
16:20	<b>FIFO CHANNEL SELECT:</b> 01101b — Left channel select 10001b — Right channel select
21:31	Reserved

**Table 53. DAI Data Register 2**

### 5.16.3 DAISR DAI Status Register

ADDRESS: 0x8000.2100

The DAI Status Register (DAISR) contains bits which signal FIFO overrun and underrun errors and FIFO service requests. Each of these conditions signal an interrupt request to the interrupt controller. The status register also flags when transmit FIFOs are not full, when the receive FIFOs are not empty, when a FIFO operation is complete, and when the right channel or left channel portion of the codec is enabled (no interrupt generated).

Bits which cause an interrupt signal the interrupt request as long as the bit is set. Once the bit is cleared, the interrupt is cleared. Read / write bits are called status bits, read-only bits are called flags. Status bits are referred to as “sticky” (once set by hardware, they must be cleared by software). Writing a one to a sticky status bit clears it, while writing a zero has no effect. Read-only flags are set and cleared by hardware, and writes have no effect. Additionally, some bits which cause interrupts have corresponding mask bits in the control register and are indicated in the section headings below. Note that the user has the ability to mask all DAI interrupts by clearing the DAI bit within the interrupt controller mask register INTMR3.

31:13	12	11	10	9	8	7
Reserved	FIFO	LCNE	LCNF	RCNE	RCNF	RCCELCRO
6	5	4	3	2	1	0
RCNFLCTU	LCRORCRO	LCTURCTU	LCRS	LCTS	LCRSRCRS	LCTSRCTS

Bit	Description
0	<p><b>RCTS:</b> Right Channel Transmit FIFO Service Request Flag (read-only)</p> <p>0 — Right Channel Transmit FIFO is more than half full (five or more entries filled) or DAI disabled</p> <p>1 — Right Channel Transmit FIFO is half full or less (four or fewer entries filled) and DAI operation is enabled, interrupt request signaled if not masked (if RCTM = 1)</p>
1	<p><b>RCRS:</b> Right Channel Receive FIFO Service Request (read-only)</p> <p>0 — Right Channel Receive FIFO is less than half full (five or fewer entries filled) or DAI disabled</p> <p>1 — Right Channel Receive FIFO is half full or more (six or more entries filled) and DAI operation is enabled, interrupt request signaled if not masked (if RCRM = 1)</p>
2	<p><b>LCTS:</b> Left Channel Transmit FIFO Service Request Flag (read-only)</p> <p>0 — Left Channel Transmit FIFO is more than half full or less (four or fewer entries filled) or DAI disabled.</p> <p>1 — Left Channel Transmit FIFO is half full or less (four or fewer entries filled) and DAI operation is enabled, interrupt request signaled if not masked (if LCTM = 1)</p>
3	<p><b>LCRS:</b> 0 — Left Channel Receive FIFO is less than half full (five or fewer entries filled) or DAI disabled.</p> <p>1 — Left Channel Receive FIFO is half full or more (six or more entries filled) and DAI operation is enabled, interrupt request signaled if not masked (if LCRM = 1)</p>

**Table 54. DAI Control, Data and Status Register Locations**

Bit	Description
4	Right Channel Transmit FIFO Underrun 0 — Right Channel Transmit FIFO has not experienced an underrun 1 — Right Channel Transmit logic attempted to fetch data from transmit FIFO while it was empty, request interrupt
5	<b>RCRO:</b> Right Channel Receive FIFO Overrun 0 — Right Channel Receive FIFO has not experienced an overrun 1 — Right Channel Receive logic attempted to place data into receive FIFO while it was full, request interrupt
6	<b>LCTU:</b> Left Channel Transmit FIFO Underrun 0 — Left Channel Transmit FIFO has not experienced an underrun 1 — Left Channel Transmit logic attempted to fetch data from transmit FIFO while it was empty, request interrupt
7	<b>LCRO:</b> Left Channel Receive FIFO Overrun 0 — Left Channel Receive FIFO has not experienced an overrun 1 — Left Channel Receive logic attempted to place data into receive FIFO while it was full, request interrupt
8	<b>RCNF:</b> Right Channel Transmit FIFO Not Full (read-only) 0 — Right Channel Transmit FIFO is full 1 — Right Channel Transmit FIFO is not full
9	<b>RCNE:</b> Right Channel Receive FIFO Not Empty (read-only) 0 — Right Channel Receive FIFO is empty 1 — Right Channel Receive FIFO is not empty
10	<b>LCNF:</b> LCNETelecom Transmit FIFO Not Full (read-only) 0 — Left Channel Transmit FIFO is full 1 — Left Channel Transmit FIFO is not full
11	<b>LCNE:</b> Left Channel Receive FIFO Not Empty (read-only) 0 — Left Channel Receive FIFO is empty 1 — Left Channel Receive FIFO is not empty
12	<b>FIFO:</b> FIFO Operation Completed (read-only) 0 — A FIFO Operation has not completed since the last time this bit was cleared 1 — The FIFO Operation was completed
13	Reserved
14	Reserved
15	Reserved
16:31	Reserved

**Table 54. DAI Control, Data and Status Register Locations (cont.)**

### 5.16.3.1 *Right Channel Transmit FIFO Service Request Flag (RCTS)*

The Right Channel Transmit FIFO Service Request Flag (RCTS) is a read-only bit which is set when the Right Channel Transmit FIFO is nearly empty and requires service to prevent an underrun. RCTS is set any time the Right Channel Transmit FIFO has four or fewer entries of valid data (half full or less), and is cleared when it has five or more entries of valid data. When the RCTS bit is set, an interrupt request is made unless the Right Channel Transmit FIFO interrupt request mask (RCTM) bit is cleared. After the CPU fills the FIFO such that four or more locations are filled within the Right Channel Transmit FIFO, the RCTS flag (and the service request and / or interrupt) is automatically cleared.

### 5.16.3.2 *Right Channel Receive FIFO Service Request Flag (RCRS)*

The Right Channel Receive FIFO Service Request Flag (RCRS) is a read-only bit which is set when the Right Channel Receive FIFO is nearly filled and requires service to prevent an overrun. RCRS is set any time the Right Channel Receive FIFO has six or more entries of valid data (half full or more), and cleared when it has five or fewer (less than half full) entries of data. When the RCRS bit is set, an interrupt request is made unless the Right Channel Receive FIFO interrupt request mask (RCRM) bit is cleared. After six or more entries are removed from the receive FIFO, the RCRS flag (and the service request and / or interrupt) is automatically cleared.

### 5.16.3.3 *Left Channel Transmit FIFO Service Request Flag (LCTS)*

The Left Channel Transmit FIFO Service Request Flag (LCTS) is a read-only bit which is set when the Left Channel Transmit FIFO is nearly empty and requires service to prevent an underrun. LCTS is set any time the Left Channel Transmit FIFO has four or fewer entries of valid data (half full or less). It is cleared when it has five or more entries of valid data. When the LCTS bit is set, an interrupt request is made unless the Left Channel Transmit FIFO interrupt request mask (LCTM) bit is cleared. After the CPU fills the FIFO such that four or more locations are filled within the Left Channel Transmit FIFO, the LCTS flag (and the service request and / or interrupt) is automatically cleared.

### 5.16.3.4 *Left Channel Receive FIFO Service Request Flag (LCRS)*

The Left Channel Receive FIFO Service Request Flag (LCRS) is a read-only bit which is set when the Left Channel Receive FIFO is nearly filled and requires service to prevent an overrun. LCRS is set any time the Left Channel Receive FIFO has six or more entries of valid data (half full or more), and cleared when it has five or fewer (less than half full) entries of data. When the LCRS bit is set, an interrupt request is made unless the Left Channel Receive FIFO interrupt request mask (LCRM) bit is cleared. After six or more entries are removed from the receive FIFO, the LCRS flag (and the service request and / or interrupt) is automatically cleared.

### 5.16.3.5 *Right Channel Transmit FIFO Underrun Status (RCTU)*

The Right Channel Transmit FIFO Underrun Status Bit (RCTU) is set when the Right Channel Transmit logic attempts to fetch data from the FIFO after it has been completely emptied. When an underrun occurs, the Right Channel Transmit logic continuously transmits the last valid right channel value which was transmitted before the underrun occurred. Once data is placed in the FIFO and it is transferred down to the bottom, the Right Channel Transmit logic uses the new value within the FIFO for transmission. When the RCTU bit is set, an interrupt request is made.

### 5.16.3.6 *Right Channel Receive FIFO Overrun Status (RCRO)*

The Right Channel Receive FIFO Overrun Status Bit (RCRO) is set when the right channel receive logic attempts to place data into the Right Channel Receive FIFO after it has been completely filled. Each time a new piece of data is received, the set signal to the RCRO status bit is asserted, and the newly received data is discarded. This process is repeated for each new sample received until at least one empty FIFO entry exists. When the RCRO bit is set, an interrupt request is made.

### 5.16.3.7 *Left Channel Transmit FIFO Underrun Status (LCTU)*

The Left Channel Transmit FIFO Underrun Status Bit (LCTU) is set when the Left Channel Transmit logic attempts to fetch data from the FIFO after it has been completely emptied. When an underrun occurs, the Left Channel Transmit logic continuously transmits the last valid left channel value which was transmitted before the underrun occurred. Once data is placed in the FIFO and it is transferred down to the bottom, the Left Channel Transmit logic uses the new value within the FIFO for transmission. When the LCTU bit is set, an interrupt request is made.

### 5.16.3.8 *Left Channel Receive FIFO Overrun Status (LCRO)*

The Left Channel Receive FIFO Overrun Status Bit (LCRO) is set when the Left Channel Receive logic places data into the Left Channel Receive FIFO after it has been completely filled. Each time a new piece of data is received, the set signal to the LCRO status bit is asserted, and the newly received sample is discarded. This process is repeated for each new piece of data received until at least one empty FIFO entry exists. When the LCRO bit is set, an interrupt request is made.

### 5.16.3.9 *Right Channel Transmit FIFO Not Full Flag (RCNF)*

The Right Channel Transmit FIFO Not Full Flag (RCNF) is a read-only bit which is set whenever the Right Channel Transmit FIFO contains one or more entries which do not contain valid data and is cleared when the FIFO is completely full. This bit can be polled when using programmed I/O to fill the Right Channel Transmit FIFO. This bit does not request an interrupt.

### 5.16.3.10 *Right Channel Receive FIFO Not Empty Flag (RCNE)*

The Right Channel Receive FIFO Not Empty Flag (RCNELCNF) is a read-only bit which is set whenever the Right Channel Receive FIFO contains one or more entries of valid data and is cleared when it no longer contains any valid data. This bit can be polled when using programmed I/O to remove remaining data from the receive FIFO. This bit does not request an interrupt.

### 5.16.3.11 *Left Channel Transmit FIFO Not Full Flag (LCNF)*

The Left Channel Transmit FIFO Not Full Flag (LCNF) is a read-only bit which is set whenever the Left Channel Transmit FIFO contains one or more entries which do not contain valid data. It is cleared when the FIFO is completely full. This bit can be polled when using programmed I/O to fill the Left Channel Transmit FIFO. This bit does not request an interrupt.

### 5.16.3.12 *Left Channel Receive FIFO Not Empty Flag (LCNE)*

The Left Channel Receive FIFO Not Empty Flag (LCNE) is a read-only bit which is set whenever the Left Channel Receive FIFO contains one or more entries of valid data and is cleared when it no longer contains any valid data. This bit can be polled when using programmed I/O to remove remaining data from the receive FIFO. This bit does not request an interrupt.

### 5.16.3.13 *FIFO Operation Completed Flag (FIFO)*

The FIFO Operation Completed (FIFO) Flag is set after the FIFO operation requested by writing to DAIDR2 as completed.

FIFO is automatically cleared when DAIDR2 is read or written. This bit does not request an interrupt.

## 6. ELECTRICAL SPECIFICATIONS

### 6.1 Absolute Maximum Ratings

DC Core, PLL, and RTC Supply Voltage	2.9 V
DC I/O Supply Voltage (Pad Ring)	3.6 V
DC Pad Input Current	±10 mA/pin; ±100 mA cumulative
Storage Temperature, No Power	-40°C to +125°C

Table 55. absolute Maximum Ratings

### 6.2 Recommended Operating Conditions

DC core, PLL, and RTC Supply Voltage	2.5 V ± 0.2 V
DC I/O Supply Voltage (Pad Ring)	2.3V - 3.6V
DC Input / Output Voltage	O-I/O supply voltage
Operating Temperature	0°C to +70°C

Table 56. Recommended Operating Conditions

### 6.3 DC Characteristics

All characteristics are specified at  $V_{DD} = 2.5$  volts and  $V_{SS} = 0$  volts over an operating temperature of 0°C to +70°C for all frequencies of operation. The current consumption figures relate to typical conditions at 2.5 V, 18.432 MHz operation with the PLL switched “on.”

Symbol	Parameter	Min	Max	Unit	Conditions
VIH	CMOS input high voltage	1.7	$V_{DD} + 0.3$	V	$V_{DD} = 2.5$ V
VIL	CMOS input low voltage	-0.3	0.8	V	$V_{DD} = 2.5$ V
VT+	Schmitt trigger positive going threshold	1.6 (Typ)	2.0	V	
VT-	Schmitt trigger negative going threshold	0.8	1.2 (Typ)	V	
Vhst	Schmitt trigger hysteresis	0.1	0.4	V	VIL to VIH
VOH	CMOS output high voltage	$V_{DD} - 0.2$		V	IOH = 0.1 mA
	Output drive 1	2.5		V	OH = 4 mA
	Output drive 2	2.5		V	OH = 12 mA
VOL	CMOS output low voltage		0.3	V	IOL = -0.1 mA
	Output drive 1		0.5	V	OL = -4 mA
	Output drive 2		0.5	V	OL = -12 mA
IIN	Input leakage current <sup>1</sup>		1	µA	VIN = $V_{DD}$ or GND
IOZ	Output tri-state leakage current <sup>2, 3</sup>	25	100	µA	VOU = $V_{DD}$ or GND
CIN	Input capacitance	8	10	pF	
COU	Output capacitance	8	10	pF	

Table 57. DC Characteristics

Symbol	Parameter	Min	Max	Unit	Conditions
CI/O	Transceiver capacitance	8	10	pF	
IDD <sub>startup</sub>	Startup current consumption			μA	Initial 100 ms from power up, 32 kHz oscillator not stable, POR signal at VIL, all other I/O static, VIH = V <sub>DD</sub> ± 0.1 V, VIL = GND ± 0.1 V
IDD <sub>standby</sub>	Standby current consumption		300	μA	Just 32 kHz oscillator running, all other I/O static, VIH = V <sub>DD</sub> ± 0.1 V, VIL = GND ± 0.1 V
IDD <sub>idle</sub>	Idle current consumption At 13 MHz At 18 MHz At 36 MHz		4.2 6 12	mA	Both oscillators running, CPU static, LCD refresh active, VIH = V <sub>DD</sub> ± 0.1 V, VIL = GND ± 0.1 V
IDD <sub>operating</sub>	Operating current consumption At 13 MHz At 18 MHz At 36 MHz At 49 MHz At 74 MHz		14 20 40 50 65	mA	All system active, running typical program
V <sub>DDstandby</sub>	Standby supply voltage	TBD		V	Minimum standby voltage for state retention and RTC operation only

**NOTE:** All power dissipation values can be derived from taking the particular IDD current and multiplying by 2.5 V.

The RTC of the EP7212 should be brought up at room temperature. This is required because the RTC OSC will NOT function properly if it is brought up at -40°C. Once operational, it will continue to operate down to -40°C.

A typical design will provide 3.3 V to the I/O supply (i.e., V<sub>DDIO</sub>), and 2.5 V to the remaining logic. This is to allow the I/O to be compatible with 3.3 V powered external logic (i.e., 3.3 V DRAMs).

Pull-up current = 50 μA typical at V<sub>DD</sub> = 3.3 volts.

**Table 57. DC Characteristics (cont.)**

1. The leakage value given assumes that the pin is configured as an input pin but is not currently being driven. An input pin not driven will have a maximum leakage of 1 μA. When the pin is driven, there will be no leakage.
2. Assumes buffer has no pull-up or pull-down resistors.
3. The leakage value given assumes that the pin is configured as an output pin but is not currently being driven. An output pin not driven will have leakage between 25μA and 100μA. When the pin is driven, there will be no leakage. Note that this applies to all output pins and all I/O pins configured as outputs.

## 6.4 AC Characteristics

All characteristics are specified at  $V_{DD} = 2.3$  to  $2.7$  volts and  $V_{SS} = 0$  volts over an operating temperature of  $0^{\circ}\text{C}$  to  $+70^{\circ}\text{C}$ . Those characteristics marked with a # will be significantly different for 13 MHz mode because the EXPCLK is provided as an input rather than generated internally. These timings are estimated at present. The timing values are referenced to  $1/2 V_{DD}$ .

Symbol	Parameter	13 MHz		18/36 MHz		Units
		Min	Max	Min	Max	
t1	Falling CS to data bus Hi-Z	0	35	0	25	ns
t2	Address change to valid write data	0	45	0	35	ns
t3	DATA in to falling EXPCLK setup time	0 #	—	18	—	ns
t4	DATA in to falling EXPCLK hold time	10 #	—	0	—	ns
t5	EXPRDY to falling EXPCLK setup time	0 #	—	18	—	ns
t6	Falling EXPCLK to EXPRDY hold time	10 #	50	0	50	ns
t7	Rising nMWE to data invalid hold time	10	—	5	—	ns
t8	Sequential data valid to falling nMWE setup time	-10	10	-10	10	ns
t9	Row address to falling nRAS setup time	5	-	5	-	ns
t10	Falling nRAS to row address hold time	25	-	25	-	ns
t11	Column address to falling nCAS setup time	2	-	2	-	ns
t12	Falling nCAS to column address hold time	25	-	25	-	ns
t13	Write data valid to falling nCAS setup time	2	-	2	-	ns
t14	Write data valid from falling nCAS hold time	50	-	50	-	ns
t15	LCD CL2 low time	80	3,475	80	3,475	ns
t16	LCD CL2 high time	80	3,475	80	3,475	ns
t17	LCD falling CL[2] to rising CL[1] delay	0	25	0	25	ns
t18	LCD falling CL[1] to rising CL[2]	80	3,475	80	3,475	ns
t19	LCD CL[1] high time	80	3,475	80	3,475	ns
t20	LCD falling CL[1] to falling CL[2]	200	6,950	200	6,950	ns
t21	LCD falling CL[1] to FRM toggle	300	10,425	300	10,425	ns
t22	LCD falling CL[1] to M toggle	-10	20	-10	20	ns
t23	LCD rising CL[2] to display data change	-10	20	-10	20	ns
t24	Falling EXPCLK to address valid	—	33 #	—	5	ns
t25	Data valid to falling nMWE for non sequential access only	5	—	5	—	ns
t31	SSICLK period (slave mode)	0	512	0	512	kHz
t32	SSICLK high	925	1025	925	1025	ns
t33	SSICLK low	925	1025	925	1025	ns
t34	SSICLK rise / fall time		7		7	ns
t35	SSICLK rising to RX and / or TX frame sync		528		528	ns
t36	SSICLK rising edge to frame sync low		448		448	ns
t37	SSICLK rising edge to TX data valid		80		80	ns
t38	SSIRXDA data set-up time	30		30		ns

**Table 58. AC Timing Characteristics**

Symbol	Parameter	13 MHz		18/36 MHz		Units
		Min	Max	Min	Max	
t39	SSIRXDA data hold time	40		40		ns
t40	SSITXFR and / or SSIRXFR period	750		750		ns

**NOTE:** All DRAM 36 MHz timings are for EDO DRAM operation.

The values for 36 MHz include 1 wait state, the 18 MHz values have 0 wait states.

**Table 58. AC Timing Characteristics (cont.)**

Symbol	Characteristics	13 MHz		18 MHz		36 MHz		Units
		Min	Max	Min	Max	Min	Max	
t <sub>nCSR</sub> D	Negative strobe (nCS[0:5]) zero wait state read access time	120		70		35		ns
t <sub>nCS</sub> WR	Negative strobe (nCS[0:5]) zero wait state write access time	120		70		35		ns
t <sub>EX</sub> BST	Sequential expansion burst mode read access time	55		35		35		ns
t <sub>RC</sub>	DRAM cycle time	230	-	150	-	150		ns
t <sub>RAC</sub>	Access time from RAS	110	-	70	-	50		ns
t <sub>RP</sub>	RAS precharge time	110	-	70	-	50		ns
t <sub>CAS</sub>	CAS pulse width	30	-	20	-	10		ns
t <sub>CP</sub>	CAS precharge in page mode	20	-	12	-	10		ns
t <sub>PC</sub>	Page mode cycle time	70	-	45	-	20		ns
t <sub>CSR</sub>	CAS set-up time for auto refresh	20	-	15	-	5		ns
t <sub>RAS</sub>	RAS pulse width	110	-	80	-	50		ns

**NOTE:** All DRAM 36 MHz timings are for EDO DRAM operation.

The values for 36 MHz include 1 wait state, the 18 MHz values have 0 wait states.

**Table 59. Timing Characteristics**

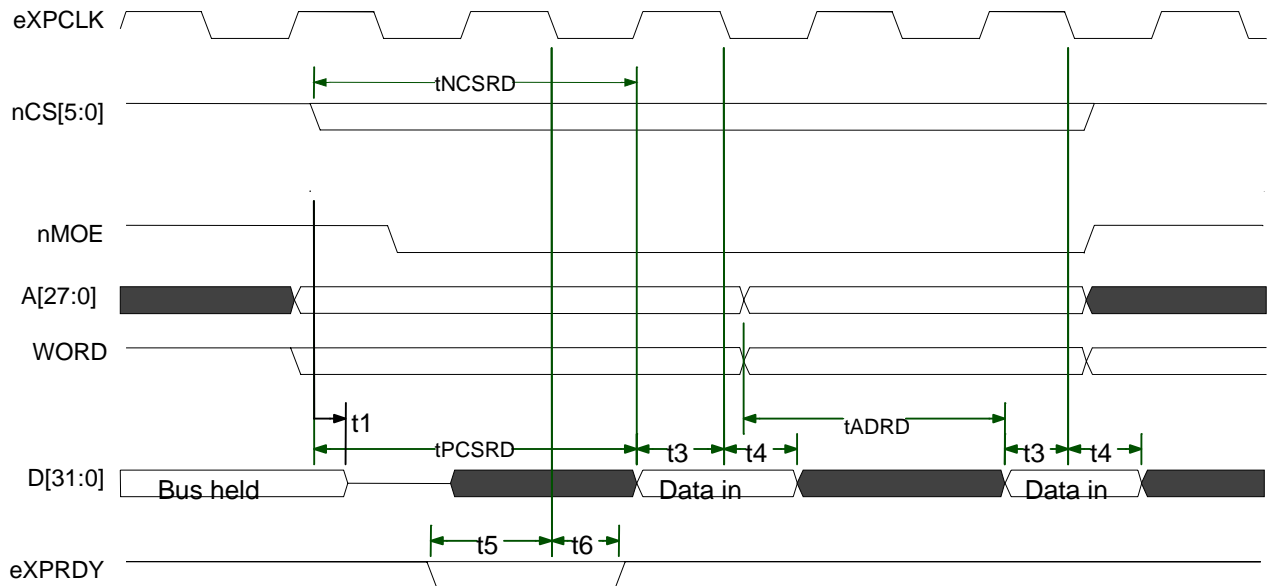
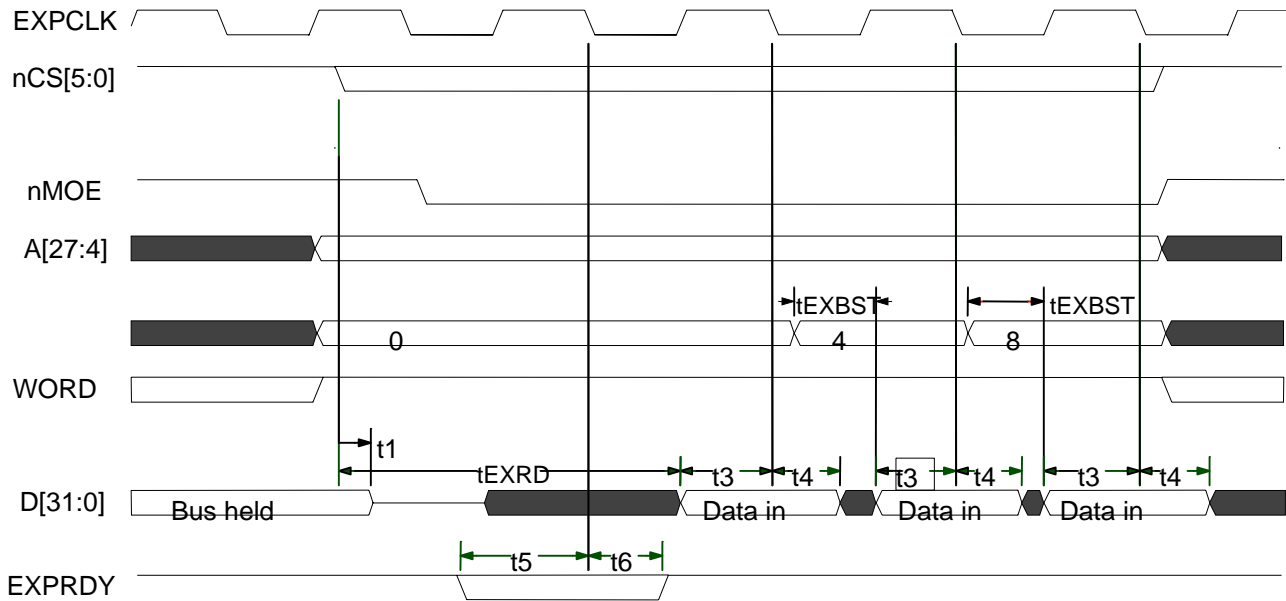

**Figure 13. Consecutive Memory Read Cycles with Minimum Wait States**

- NOTES:**
- 1)  $t_{nCSRd} = 50 \text{ ns}$  at 36.864 MHz  
 $70 \text{ ns}$  at 18.432 MHz  
 $120 \text{ ns}$  at 13.0 MHz

Maximum values for minimum wait states. This time can be extended by integer multiples of the clock period (27 ns at 36 MHz, 54 ns at 18.432 MHz, and 77 ns at 1 MHz), by either driving EXPRDY low and/or by programming a number of wait states. EXPRDY is sampled on the falling edge of EXPCLK before the data transfer. If low at this point, the transfer is delayed by one clock period where EXPRDY is sampled again. EXPCLK need not be referenced when driving EXPRDY, but is shown for clarity.

- 2) Consecutive reads with sequential access enabled are identical except that the sequential access wait state field is used to determine the number of wait states, and no idle cycles are inserted between successive non-sequential ROM/expansion cycles. This improves performance so the SQAEN bit should always be set where possible.
- 3)  $t_{nCSRd} = t_{ADRD} = t_{PCSRd}$
- 4) When the EP72xx device implements consecutive reads(e.g., use of the LDM instruction), regardless of the state of the SQAEN bit, the signals nMOE and nCSx will always remain low through the entire multi-read access. They will not toggle in-between each different address access. In order to have these signals toggle, single access read instructions (e.g., LDR) must be used.

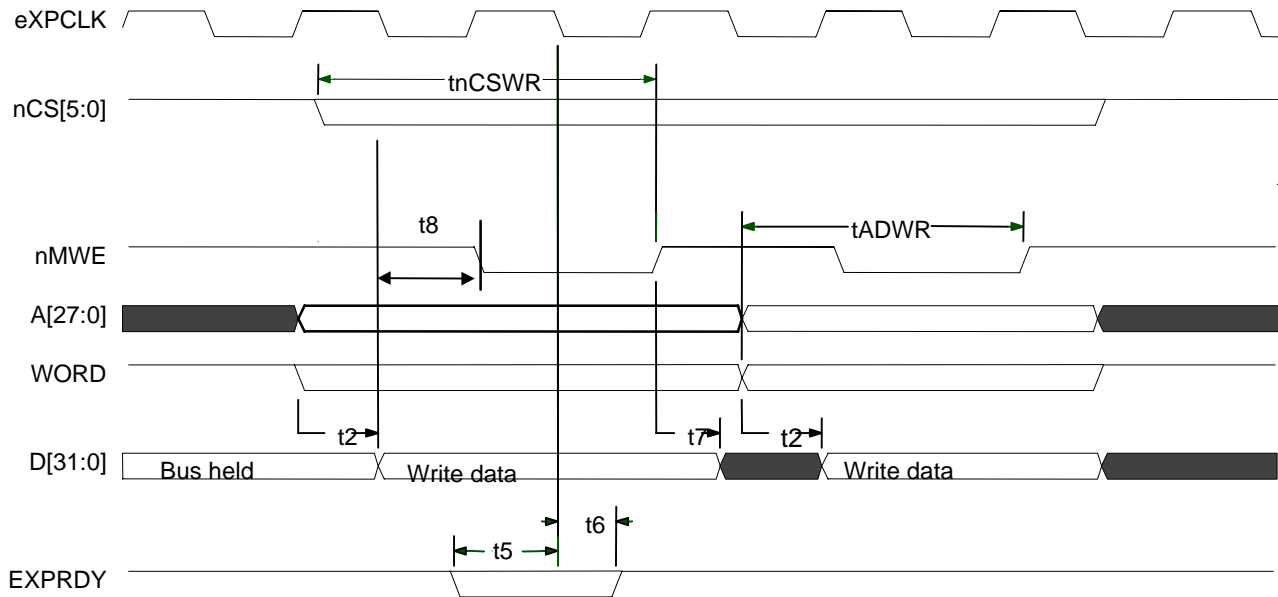

**Figure 14. Sequential Page Mode Read Cycles with Minimum Wait States**

- NOTES:**
- 1)  $t_{EXBST} = 35 \text{ ns}$  at 36.864 MHz  
 $35 \text{ ns}$  at 18.432 MHz  
 $55 \text{ ns}$  at 13.0 MHz  
(Value for 36.864 MHz assumes 1 wait state.)

Maximum values for minimum wait states. This time can be extended by integer multiples of the clock period (27 nsec at 36 MHz, 54 nsec at 18.432 MHz and 77 ns at 13 MHz), by either driving EXPRDY low and/or by programming a number of wait states. EXPRDY is sampled on the falling edge of EXPCLK before the data transfer. If low at this point, the transfer is delayed by one clock period where EXPRDY is sampled again. EXPCLK need not be referenced when driving EXPRDY, but is shown for clarity.

- 2) Consecutive reads with sequential access enabled are identical except that the sequential access wait state field is used to determine the number of wait states, and no idle cycles are inserted between successive non-sequential ROM/expansion cycles. This improves performance so the SQAEN bit should always be set where possible.

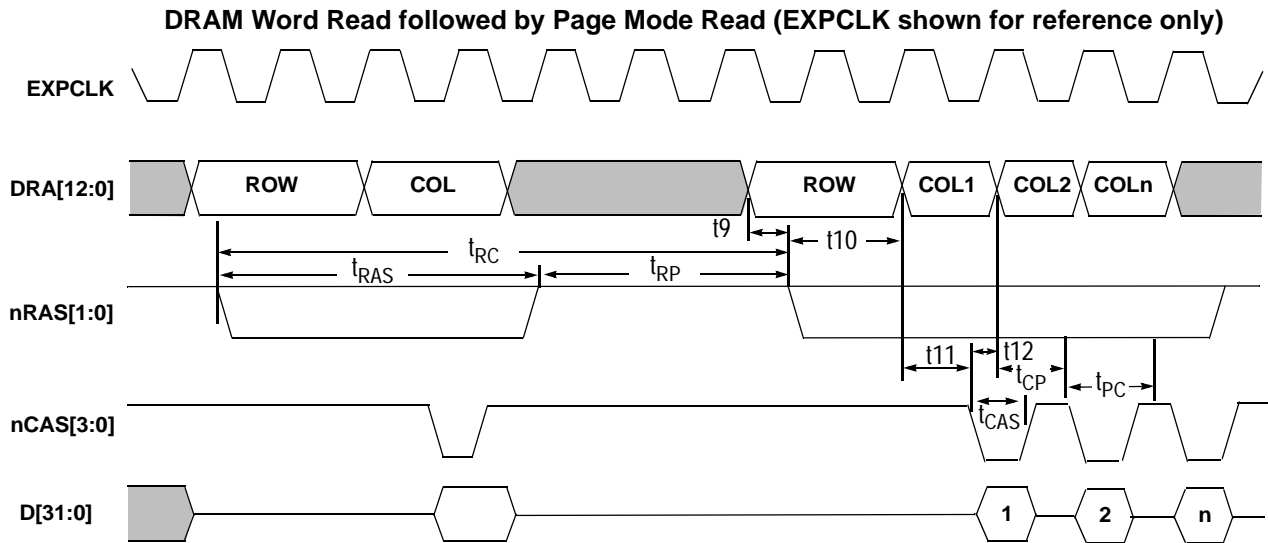

**Figure 15. Consecutive Memory Write Cycles with Minimum Wait States**

- NOTES:**
- 1)  $t_{nCSWR} = 35 \text{ nsec}$  at 36.864 MHz  
 $70 \text{ ns}$  at 18.432 MHz  
 $120 \text{ ns}$  at 13.0 MHz

Maximum values for minimum wait states. This time can be extended by integer multiples of the clock period (27 nsec at 36 MHz, 54 nsec at 18.432 MHz, and 77 nsec at 13 MHz), by either driving EXPRDY low and/or by programming a number of wait states. EXPRDY is sampled on the falling edge of EXPCLK before the data transfer. If low at this point, the transfer is delayed by one clock period where EXPRDY is sampled again. EXPCLK need not be referenced when driving EXPRDY, but is shown for clarity.

- 2) Consecutive reads with sequential access enabled are identical except that the sequential access wait state field is used to determine the number of wait states, and no idle cycles are inserted between successive non-sequential ROM/expansion cycles. This improves performance so the SQAEN bit should always be set where possible.
- 3) Zero wait states for sequential writes is not permitted for memory devices which use nMWE pin, as this cannot be driven with valid timing under zero wait state conditions.



**Figure 16. DRAM Read Cycles at 13 MHz and 18.432 MHz**

- NOTES:**
- 1)  $t_{RC}$  (Read cycle time) = 150 ns max at 18.432 MHz and 230 ns at 13 MHz
  - 2)  $t_{RAS}$  (RAS pulse width) = 70 ns max at 18.432 MHz and 110 ns at 13 MHz
  - 3)  $t_{RP}$  (RAS precharge time) = 70 ns max at 18.432 MHz and 110 ns at 13 MHz
  - 4)  $t_{CAS}$  (CAS pulse width) = 20 ns max at 18.432 MHz and 30 ns at 13 MHz
  - 5)  $t_{CP}$  (CAS precharge in page mode) = 12 ns max at 18.432 MHz and 20 ns at 13 MHz
  - 6)  $t_{PC}$  (Page mode cycle time) = 45 ns min at max at 18.432 MHz and 70 ns at 13 MHz

Word reads shown, for byte reads, only one off **nCAS[3:0]** will be active, **nCAS0** for byte 0, etc.

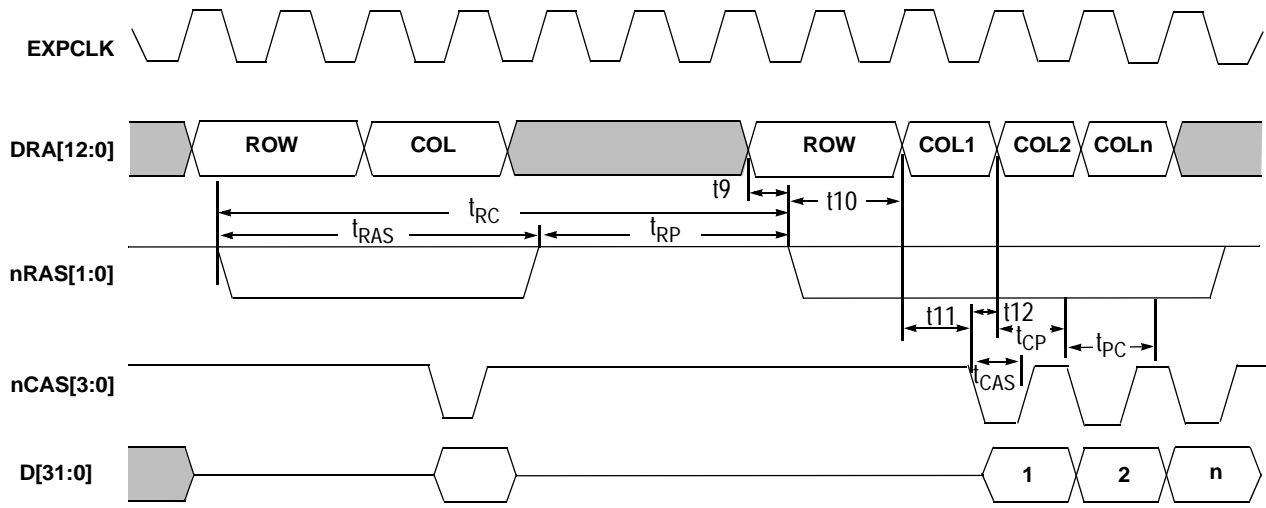

**Figure 17. DRAM Read Cycles at 36 MHz**

- NOTES:**
- 1)  $t_{RC}$  (read cycle time) = 150 ns max
  - 2)  $t_{RAS}$  (RAS pulse width) = 70 ns max
  - 3)  $t_{RP}$  (RAS precharge time) = 70 ns max
  - 4)  $t_{CAS}$  (CAS pulse width) = 10 ns max
  - 5)  $t_{CP}$  (CAS precharge in page mode) = 10 ns max
  - 6)  $t_{PC}$  (Page mode cycle time) = 25 ns max

Word reads shown, for byte reads, only one off **nCAS[3:0]** will be active, **nCAS[0]** for byte 0, etc.

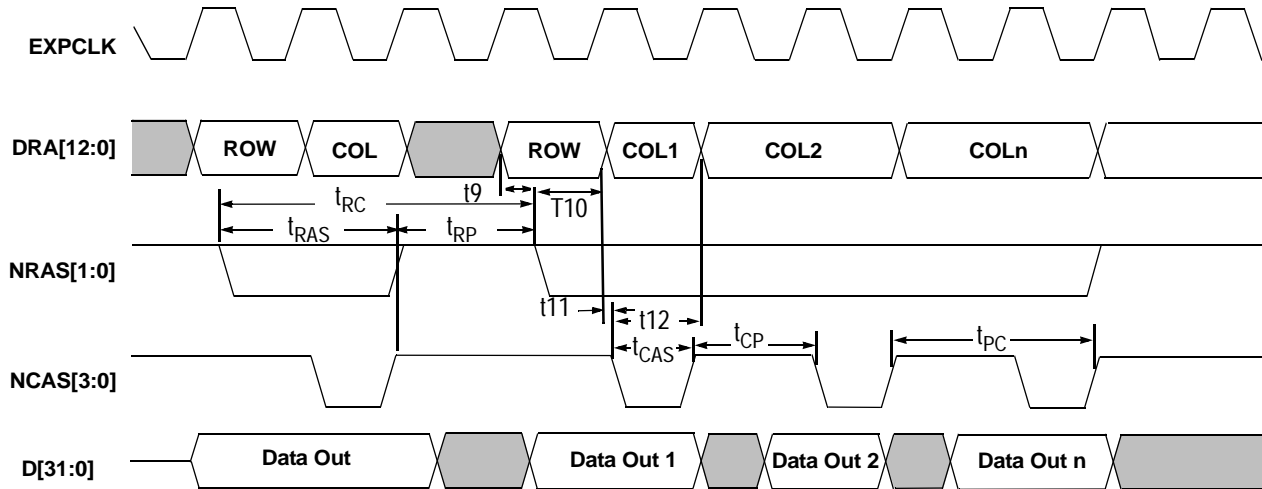

**Figure 18. DRAM Write Cycles at 13 MHz and 18 MHz**

- NOTES:**
- 1)  $t_{RC}$  (Write cycle time) = 150 ns max at 18.432 MHz and 230 ns at 13 MHz
  - 2)  $t_{RAS}$  (RAS pulse width) = 70 ns max at 18.432 MHz and 110 ns at 13 MHz
  - 3)  $t_{RP}$  (RAS precharge time) = 70 ns max at 18.432 MHz and 110 ns at 13 MHz
  - 4)  $t_{CAS}$  (CAS pulse width) = 20 ns max at 18.432 MHz and 30 ns at 13 MHz
  - 5)  $t_{CP}$  (CAS precharge in page mode) = 66 ns max at 18.432 MHz and 140 ns at 13 MHz
  - 6)  $t_{PC}$  (Page mode cycle time) = 100 ns min at max at 18.432 MHz and 140 ns at 13 MHz

Word writes shown, for byte writes, only one off **nCAS[3:0]** will be active, **nCAS0** for byte 0, etc.

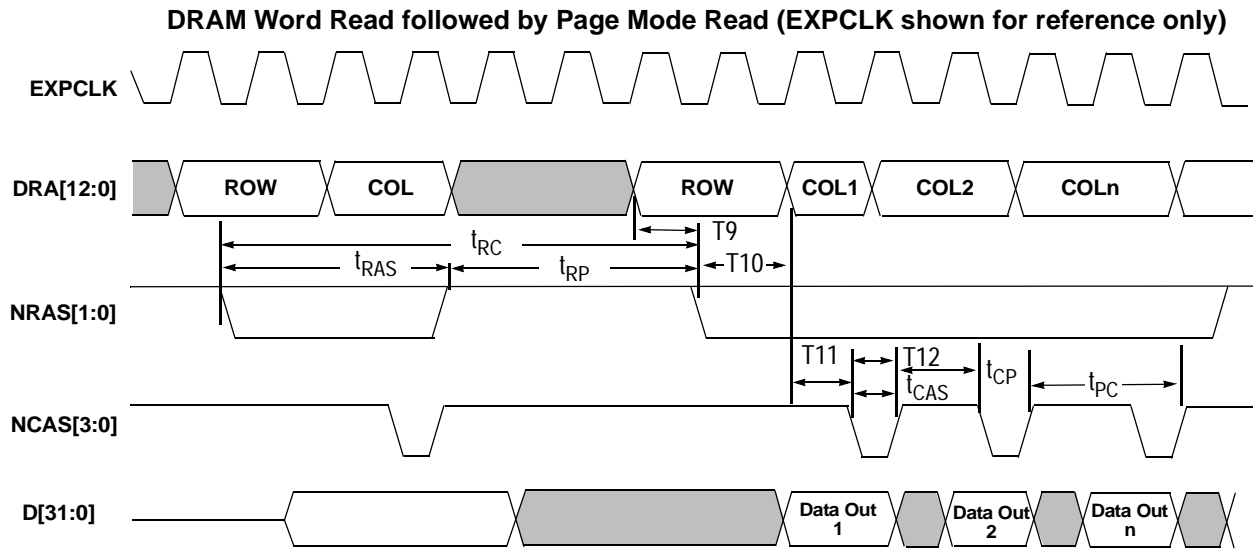

**Figure 19. DRAM Write Cycles at 36 MHz**

- NOTES:**
- 1)  $t_{RC}$  (Write cycle time) = 150 ns max
  - 2)  $t_{RAS}$  (RAS pulse width) = 70 ns max
  - 3)  $t_{RP}$  (RAS precharge time) = 70 ns max
  - 4)  $t_{CAS}$  (CAS pulse width) = 10 ns max
  - 5)  $t_{CP}$  (CAS precharge in page mode) = 35 ns max
  - 6)  $t_{PC}$  (Page mode cycle time) = 50 ns max

Word reads shown, for byte reads, only one off **nCAS[3:0]** will be active, **nCAS[0]** for byte 0, etc.

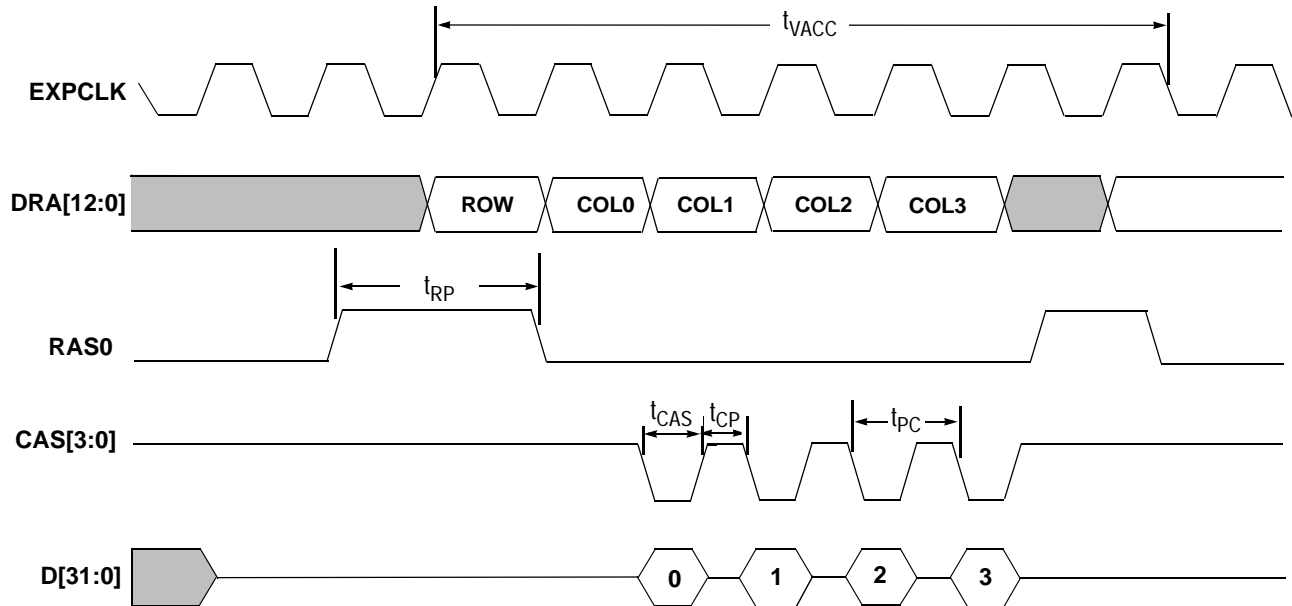

**Figure 20. Video Quad Word Read from DRAM at 13 MHz and 18 MHz**

- NOTES:**
- 1). Timings are the same as page mode word reads
  - 2)  $t_{VACC}$  (video access cycle time) = 326 ns at EXPCLK = 18.432 MHz and 462 ns at 13 MHz

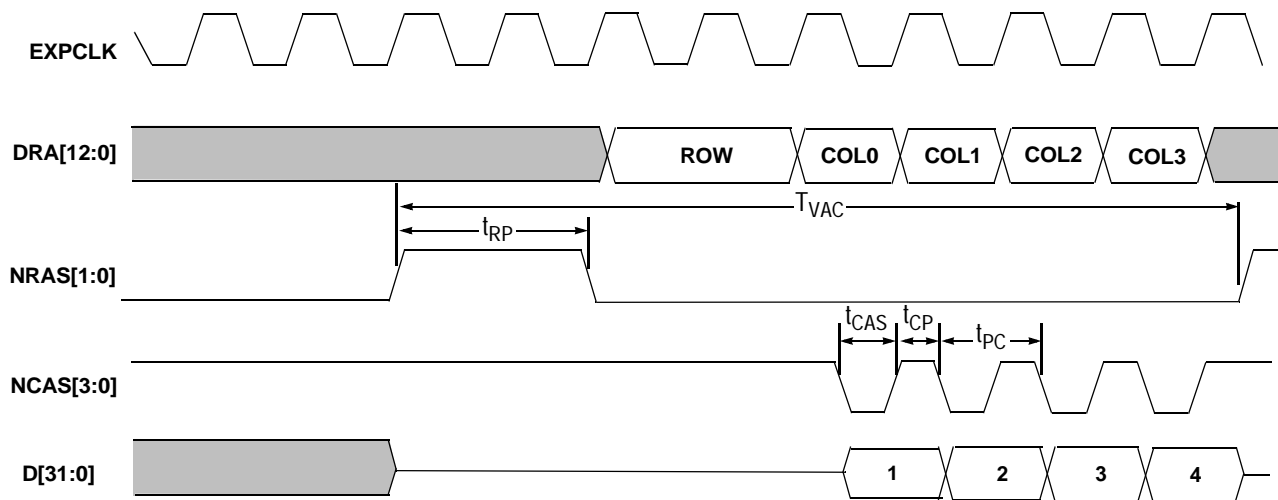

**Figure 21. Quad Word Read from DRAM at 36 MHz**

- NOTES:**
- 1). Timings are the same as page mode word reads
  - 2)  $t_{VACC}$  (video access cycle time) = 220 ns at EXPCLK = 36 MHz
  - 3) The filled-in grey areas are don't cares.

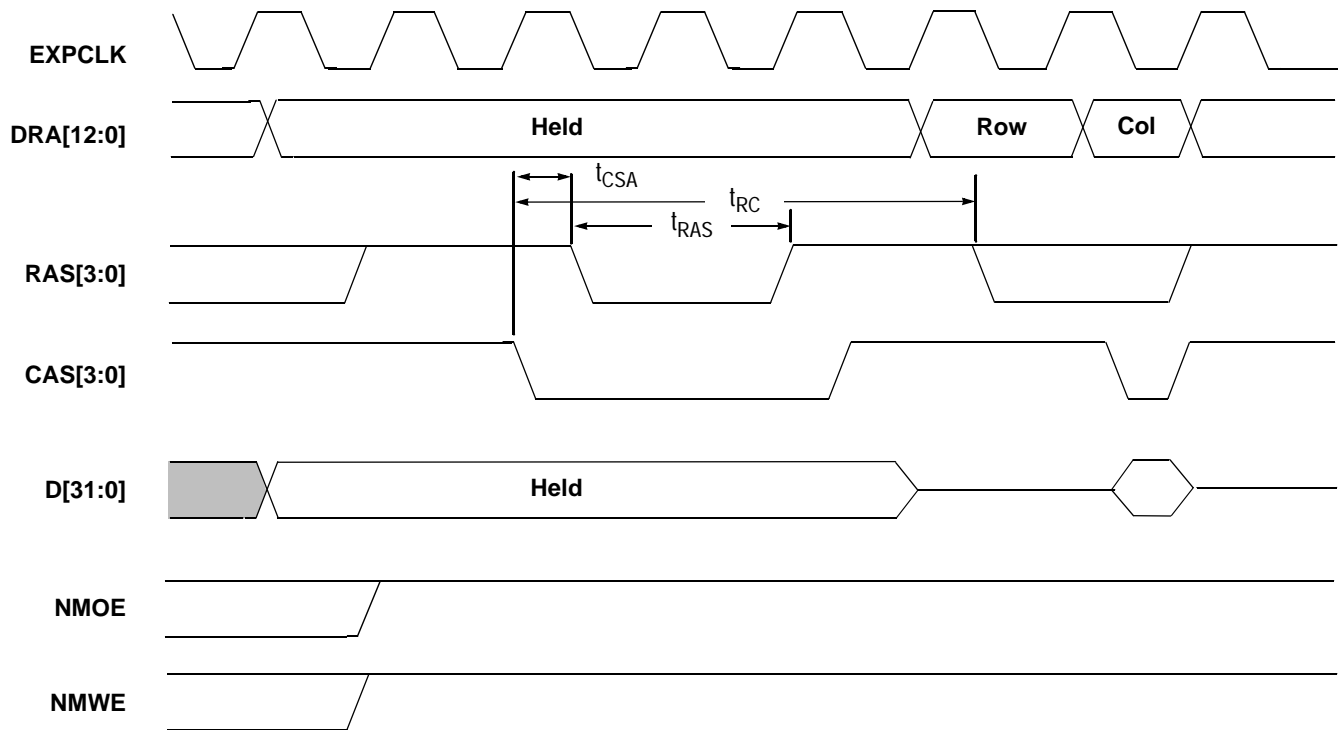
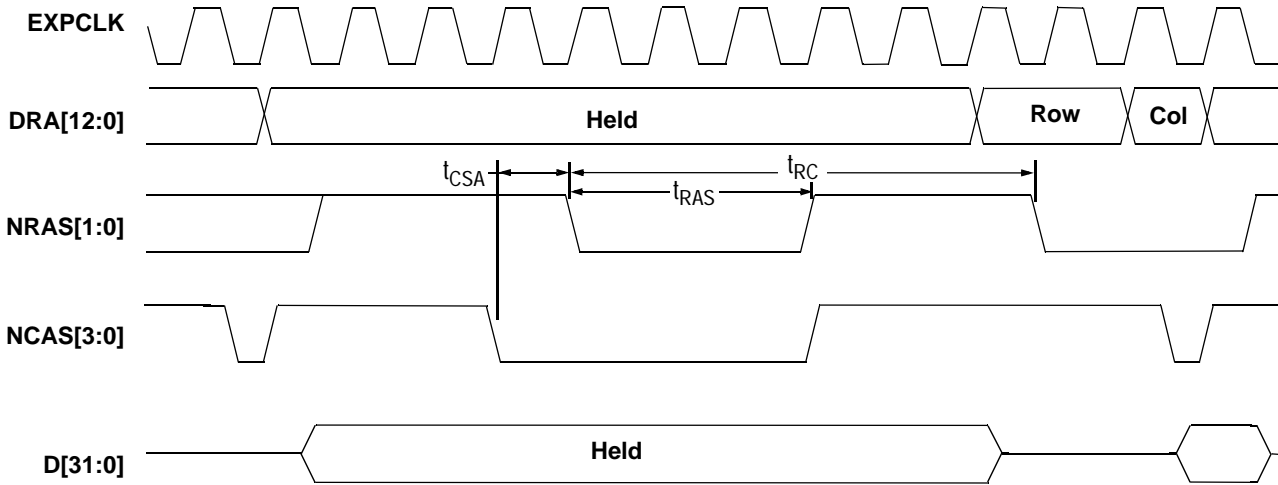

**Figure 22. DRAM CAS Before RAS Refresh Cycle at 13 MHz and 18 MHz**

**NOTES:**

- 1).  $t_{CSA}$  (CAS set-up time) = 15 ns max at 18.432 MHz and 20 ns at 13 MHz
- 2).  $t_{RAS}$  (RAS pulse width) = 70 ns max at 18.432 MHz and 110 ns at 13 MHz
- 3).  $t_{RC}$  (cycle time) = 180 ns max at 18.432 MHz and 230 ns at 13 MHz
- 4). The filled-in grey area is a don't care.

When DRAMs are placed in self-refresh (entering the Standby State), the same timings, except that  $t_{RAS}$  is extended indefinitely.



**Figure 23. DRAM CAS Before RAS Refresh Cycle at 36 MHz**

- NOTES:**
- 1)  $t_{CSA}$  (CAS set-up time) = 8 ns max
  - 2)  $t_{RAS}$  (RAS pulse width) = 60 ns max
  - 3)  $t_{RC}$  (cycle time) = 167 ns max

When DRAMs are placed in self-refresh (entering the Standby State), the same timings, except that  $t_{RAS}$  is extended indefinitely.

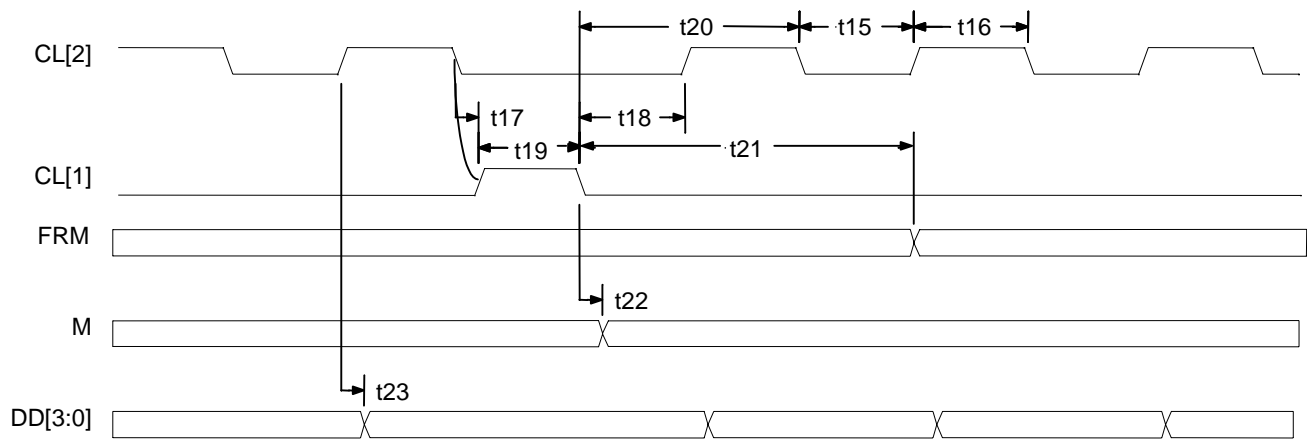

- NOTES:**
- 1) The figure shows the end of a line.
  - 2) If FRM is high during the CL[1] pulse, this marks the first line in the display.
  - 3) CL[2] low time is doubled during the CL[1] high pulse

**Figure 24. LCD Controller Timings**

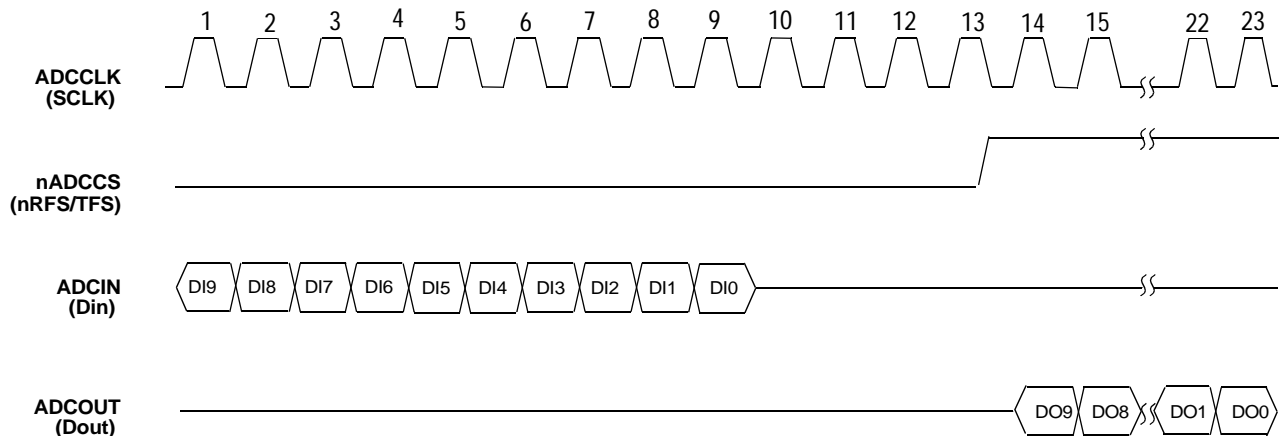
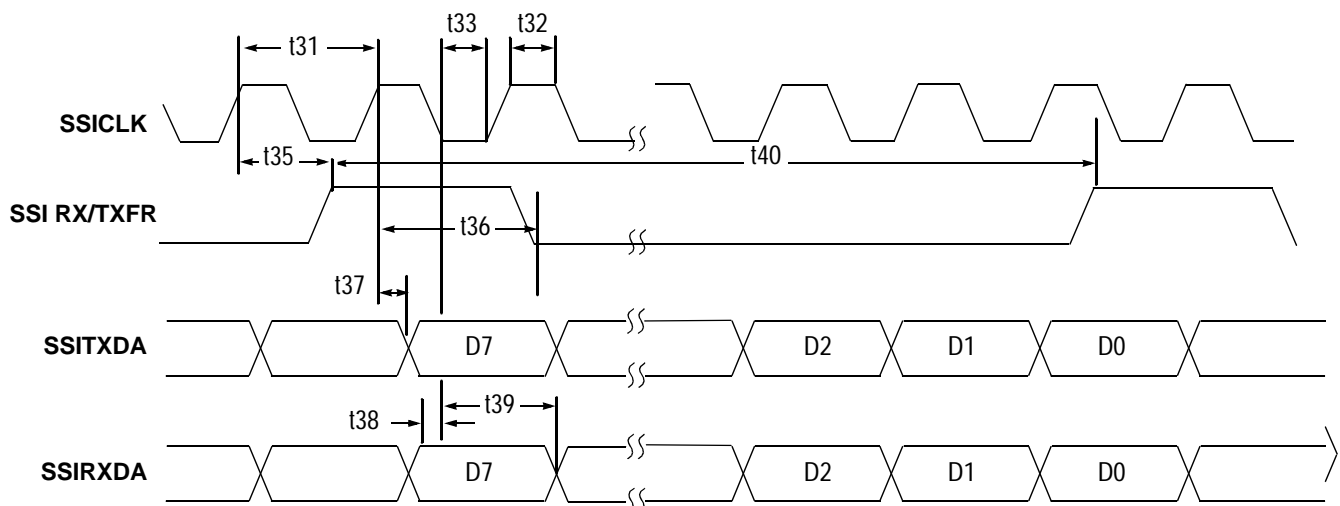
**Figure 25. SSI Interface for AD7811/2**

**Figure 26. SSI2 Interface Timings**

## 6.5 I/O Buffer Characteristics

All I/O buffers on the EP7212 are CMOS threshold input bidirectional buffers except the oscillator and power pads. For signals that are nominally inputs, the output buffer is only enabled during pin test mode. All output buffers are three stated during system (hi-Z) test mode. All buffers have a standard CMOS threshold input stage (apart from the Schmitt-triggered inputs) and CMOS slew-rate-

controlled output stages to reduce system noise. [Table 60](#) defines the I/O buffer output characteristics which will apply across the full range of temperature and voltage (i.e., these values are for 3.3 V, +70°C).

All propagation delays are specified at 50%  $V_{DD}$  to 50%  $V_{DD}$ , all rise times are specified as 10%  $V_{DD}$  to 90%  $V_{DD}$  and all fall times are specified as 90%  $V_{DD}$  to 10%  $V_{DD}$ .

Buffer Type	Drive Current	Propagation Delay (Max)	Rise Time (Max)	Fall Time (Max)	Load
I/O strength 1	±4 mA	7	14	14	50 pF
I/O strength 2	±12 mA	5	6	6	50 pF

**Table 60. I/O Buffer Output Characteristics**

## 6.6 JTAG Boundary Scan Signal Ordering

Pin No.	Signal	Type	Strength	Reset State
1	nCS[5]	Out	1	High
2	VDDIO	Pad Pwr		
3	VSSIO	Pad Gnd		
4	EXPCLK	I/O	1	
5	WORD	Out	1	Low
6	WRITE	Out	1	Low
7	RUN/CLKEN	I/O	1	Low
8	EXPRDY	In	1	
9	TXD[2]	Out	1	High
10	RXD[2]	In		
11	TDI	In	with p/u*	
12	VSSIO	Pad Gnd		
13	PB[7]	I/O	1	Input
14	PB[6]	I/O	1	Input
15	PB[5]	I/O	1	Input
16	PB[4]	I/O	1	Input
17	PB[3]	I/O	1	Input
18	PB[2]	I/O	1	Input
19	PB[1]/PRDY2	I/O	1	Input
20	PB[0]/PRDY1	I/O	1	Input
21	VDDIO	Pad Pwr		
22	TDO	Out	1	Tristate
23	PA[7]	I/O	1	Input
24	PA[6]	I/O	1	Input
25	PA[5]	I/O	1	Input
26	PA[4]	I/O	1	Input
27	PA[3]	I/O	1	Input
28	PA[2]	I/O	1	Input
29	PA[1]	I/O	1	Input
30	PA[0]	I/O	1	Input
31	LEDDR	Out	1	Low

**Table 61. 208-Pin LQFP Numeric Pin Listing**

Pin No.	Signal	Type	Strength	Reset State
32	TXD[1]	Out	1	High
33	VSSIO	Pad Gnd	1	High
34	PHDIN	In		
35	CTS	In		
36	RXD[1]	In		
37	DCD	In		
38	DSR	In		
39	nTEST[1]	In	With p/u*	
40	nTEST[0]	In	With p/u*	
41	EINT[3]	In		
42	nEINT[2]	In		
43	nEINT[1]	In		
44	nEXTFIQ	In		
45	PE[2]/CLKSEL	I/O	1	Input
46	PE[1]/BOOTSEL[1]	I/O	1	Input
47	PE[0]/BOOTSEL[0]	I/O	1	Input
48	VSSRTC	RTC Gnd		
49	RTCOU	Out		
50	RTCIN	In		
51	VDDRRTC	RTC power		
52	N/C			
53	PD[7]	I/O	1	Low
54	PD[6]	I/O	1	Low
55	PD[5]	I/O	1	Low
56	PD[4]	I/O	1	Low
57	VDDIO	Pad Pwr		
58	TMS	In	with p/u*	
59	PD[3]	I/O	1	Low

**Table 61. 208-Pin LQFP Numeric Pin Listing (cont.)**

Pin No.	Signal	Type	Strength	Reset State
60	PD[2]	I/O	1	Low
61	PD[1]	I/O	1	Low
62	PD[0]/ LEDFLSH	I/O	1	Low
63	SSICLK	I/O	1	Input
64	VSSIO	Pad Gnd		
65	SSITXFR	I/O	1	Low
66	SSITXDA	Out	1	Low
67	SSIRXDA	In		
68	SSIRXFR	I/O		Input
69	ADCIN	In		
70	nADCCS	Out	1	High
71	VSSCORE	Core Gnd		
72	VDDCORE	Core Pwr		
73	VSSIO	Pad Gnd		
74	VDDIO	Pad Pwr		
75	DRIVE[1]	I/O	1	High / Low
76	DRIVE[0]	I/O	1	High / Low
77	ADCCLK	Out	1	Low
78	ADCOUT	Out	1	Low
79	SMPCLK	Out	1	Low
80	FB[1]	In		
81	VSSIO	Pad Gnd		
82	FB[0]	In		
83	COL[7]	Out	1	High
84	COL[6]	Out	1	High
85	COL[5]	Out	1	High
86	COL[4]	Out	1	High
87	COL[3]	Out	1	High
88	COL[2]	Out	1	High
89	VDDIO	Pad Pwr		
90	TCLK	In		
91	COL[1]	Out	1	High
92	COL[0]	Out	1	High
93	BUZ	Out	1	Low
94	D[31]	I/O	1	Low
95	D[30]	I/O	1	Low

**Table 61. 208-Pin LQFP Numeric Pin Listing (cont.)**

Pin No.	Signal	Type	Strength	Reset State
96	D[29]	I/O	1	Low
97	D[28]	I/O	1	Low
98	VSSIO	Pad Gnd		
99	A[27]	Out	2	Low
100	D[27]	I/O	1	Low
101	A[26]	Out	2	Low
102	D[26]	I/O	1	Low
103	A[25]	Out	2	Low
104	D[25]	I/O	1	Low
105	HALFWORD	Out	1	Low
106	A[24]	Out	1	Low
107	VDDIO	Pad Pwr		—
108	VSSIO	Pad Gnd		—
109	D[24]	I/O	1	Low
110	A[23]	Out	1	Low
111	D[23]	I/O	1	Low
112	A[22]	Out	1	Low
113	D[22]	I/O	1	Low
114	A[21]	Out	1	Low
115	D[21]	I/O	1	Low
116	VSSIO	Pad Gnd		
117	A[20]	Out	1	Low
118	D[20]	I/O	1	Low
119	A[19]	Out	1	Low
120	D[19]	I/O	1	Low
121	A[18]	Out	1	Low
122	D[18]	I/O	1	Low
123	VDDIO	Pad Pwr		
124	VSSIO	Pad Gnd		
125	nTRST	In		
126	A[17]	Out	1	Low
127	D[17]	I/O	1	Low
128	A[16]	Out	1	Low
129	D[16]	I/O	1	Low
130	A[15]	Out	1	Low
131	D[15]	I/O	1	Low
132	A[14]	Out	1	Low
133	D[14]	I/O	1	Low
134	A[13]	Out	1	Low
135	D[13]	I/O	1	Low

**Table 61. 208-Pin LQFP Numeric Pin Listing (cont.)**

Pin No.	Signal	Type	Strength	Reset State
136	A[12]	Out	1	Low
137	D[12]	I/O	1	Low
138	A[11]	Out	1	Low
139	VDDIO	Pad Pwr		
140	VSSIO	Pad Gnd		
141	D[11]	I/O	1	Low
142	A[10]	Out	1	Low
143	D[10]	I/O	1	Low
144	A[9]	Out	1	Low
145	D[9]	I/O	1	Low
146	A[8]	Out	1	Low
147	D[8]	I/O	1	Low
148	A[7]	Out	1	Low
149	VSSIO	Pad Gnd		
150	D[7]	I/O	1	Low
151	nBATCHG	In		
152	nEXTPWR	In		
153	BATOK	In		
154	nPOR	In	Schmitt	
155	nMEDCHG/ nBROM	In		
156	nURESET	In	Schmitt	
157	VDDOSC	Osc Pwr		
158	MOSCIN	Osc		
159	MOSCOU	Osc		
160	VSSOSC	Osc Gnd		
161	WAKEUP	In	Schmitt	
162	nPWRFL	In		
163	A[6]	Out	1	Low
164	D[6]	I/O	1	Low
165	A[5]	Out	1	Low
166	D[5]	I/O	1	Low
167	VDDIO	Pad Pwr		
168	VSSIO	Pad Gnd		
169	A[4]	Out	1	Low
170	D[4]	I/O	1	Low
171	A[3]	Out	2	Low
172	D[3]	I/O	1	Low
173	A[2]	Out	2	Low
174	VSSIO	Pad Gnd		

**Table 61. 208-Pin LQFP Numeric Pin Listing (cont.)**

Pin No.	Signal	Type	Strength	Reset State
175	D[2]	I/O	1	Low
176	A[1]	Out	1	Low
177	D[1]	I/O	1	Low
178	A[0]	Out	1	Low
179	D[0]	I/O	1	Low
180	VSS CORE	Core Gnd		
181	VDD CORE	Core Pwr		
182	VSSIO	Pad Gnd		
183	VDDIO	Pad Pwr		
184	CL[2]	Out	1	Low
185	CL[1]	Out	1	Low
186	FRM	Out	1	Low
187	M	Out	1	Low
188	DD[3]	I/O	1	Low
189	DD[2]	I/O	1	Low
190	VSSIO	Pad Gnd		
191	DD[1]	I/O	1	Low
192	DD[0]	I/O	1	Low
193	N/C			
194	N/C			
195	N/C			
196	N/C			
197	VDDIO	Pad Pwr		
198	VSSIO	Pad Gnd		
199	N/C			
200	N/C			
201	nMWE	Out	1	High
202	nMOE	Out	1	High
203	VSSIO	Pad Gnd		
204	nCS[0]	Out	1	High
205	nCS[1]	Out	1	High
206	nCS[2]	Out	1	High
207	nCS[3]	Out	1	High
208	nCS[4]	Out	1	High

**NOTE:** 'With p/u' means with internal pull-up on the pin.

**Table 61. 208-Pin LQFP Numeric Pin Listing (cont.)**

## 7. TEST MODES

The EP7212 supports a number of hardware activated test modes, these are activated by the pin combinations shown in [Table 62](#). All latched signals will only alter test modes while NPOR is low, their state is latched on the rising edge of NPOR. This allows these signals to be used normally during various test modes.

Within each test mode, a selection of pins is used as multiplexed outputs or inputs to provide / monitor the test signals unique to that mode.

### 7.1 Oscillator and PLL Bypass Mode

This mode is selected by  $nTEST[0] = 1$ ,  $nTEST[1] = 0$ .

In this mode, all the internal oscillators and PLL are disabled, and the appropriate crystal oscillator pins become the direct external oscillator inputs bypassing the oscillator and PLL. MOSCIN must be driven by a 36.864 MHz clock source and RTCIN by a 32.768 kHz source.

### 7.2 Oscillator and PLL Test Mode

This mode is selected by  $nTEST[0] = 0$ ,  $nTEST[1] = 1$ , Latched  $nURESET = 0$

This test mode will enable the main oscillator and will output various buffered clock and test signals derived from the main oscillator, PLL, and 32-kHz oscillator. All internal logic in the EP7212 will be static and isolated from the oscillators, with the exception of the 6-bit ripple counter used to generate 576 kHz and the Real Time Clock divide chain. Port A is used to drive the inputs of the PLL directly, and the various clock and PLL outputs are monitored on the COL pins. [Table 63](#) defines the EP7212 signal pins used in this test mode. This mode is only intended to allow test of the oscillators and PLL. Note that these inputs are inverted before being passed to the PLL to ensure that the default state of the port (all zero) maps onto the correct default state of the PLL ( $TSEL = 1$ ,  $XTALON = 1$ ,  $PLLON = 1$ ,  $D0 = 0$ ,  $D1 = 1$ ,  $PLLBP = 0$ ). This state will produce the correct frequencies as shown in [Table 63](#). Any other combinations are for testing the oscillator and PLL and should not be used in-circuit.

Test Mode	Latched nMEDCHG	Latched PE[0]	Latched PE[1]	Latched nURESET	nTEST[0]	nTEST[1]
Normal operation (32-bit boot)	1	0	0	X	1	1
Normal operation (8-bit boot)	1	1	0	X	1	1
Normal operation (16-bit boot)	1	0	1	X	1	1
Alternative test ROM boot	0	X	X	X	1	1
Oscillator / PLL bypass	X	X	X	X	1	0
Oscillator / PLL test mode	X	X	X	0	0	1
ICE Mode	X	X	X	1	0	0
System test (all HiZ)	X	X	X	0	0	0

**Table 62. EP7212 Hardware Test Modes**

Signal	I/O	Pin	Function
TSEL *	I	PA5	PLL test mode
XTLON *	I	PA4	Enable to oscillator circuit
PLLON *	I	PA3	Enable to PLL circuit
PLLBP	I	PA0	Bypasses PLL
RTCCLK	O	COL0	Output of RTC oscillator
CLK1	O	COL1	1 Hz clock from RTC divider chain
OSC36	O	COL2	36 MHz divided PLL main clock
CLK576K	O	COL4	576 KHz divided from above
VREF	O	COL6	Test clock output for PLL

**Table 63. Oscillator and PLL Test Mode Signals**

### 7.3 Debug / ICE Test Mode

This mode is selected by nTEST0 = 0, nTEST1 = 0, Latched nURESET = 1.

Selection of this mode enables the debug mode of the ARM720T. By default, this is disabled which saves approximately 3% on power.

### 7.4 Hi-Z (System) Test Mode

This mode selected by nTEST0 = 0, nTEST1 = 0, Latched nURESET = 0.

This test mode asynchronously disables all output buffers on the EP7212. This has the effect of removing the EP7212 from the PCB so that other devices on the PCB can be in-circuit tested. The internal state of the EP7212 is not altered directly by this test mode.

### 7.5 Software Selectable Test Functionality

When bit 11 of the SYSCON register is set high, internal peripheral bus register accesses are output on the main address and data buses as though they were external accesses to the address space addressed by nCS[5]. Hence, nCS[5] takes on a dual role, it will be active as the strobe for internal ac-

cesses and for any accesses to the standard address range for nCS[5]. Additionally, in this mode, the internal signals shown in Table 64 are multiplexed out of the device on port pins.

Signal	I/O	Pin	Function
CLK	O	PE0	Waited clock to CPU
nFIQ	O	PE1	nFIQ interrupt to CPU
nIRQ	O	PE2	nIRQ interrupt to CPU

**Table 64. Software Selectable Test Functionality**

This test is not intended to be used when LCD DMA accesses are enabled. This is due to the fact that it is possible to have internal peripheral bus activity simultaneously with a DMA transfer. This would cause bus contention to occur on the external bus.

The “Waited clock to CPU” is an internally ANDed source that generates the actual CPU clock. Thus, it is possible to know exactly when the CPU is being clocked by viewing this pin. The signals nFIQ and nIRQ are the two output signals from the internal interrupt controller. They are input directly into the ARM720T processor.

## 8. PIN INFORMATION

### 8.1 208-Pin LQFP Pin Diagram

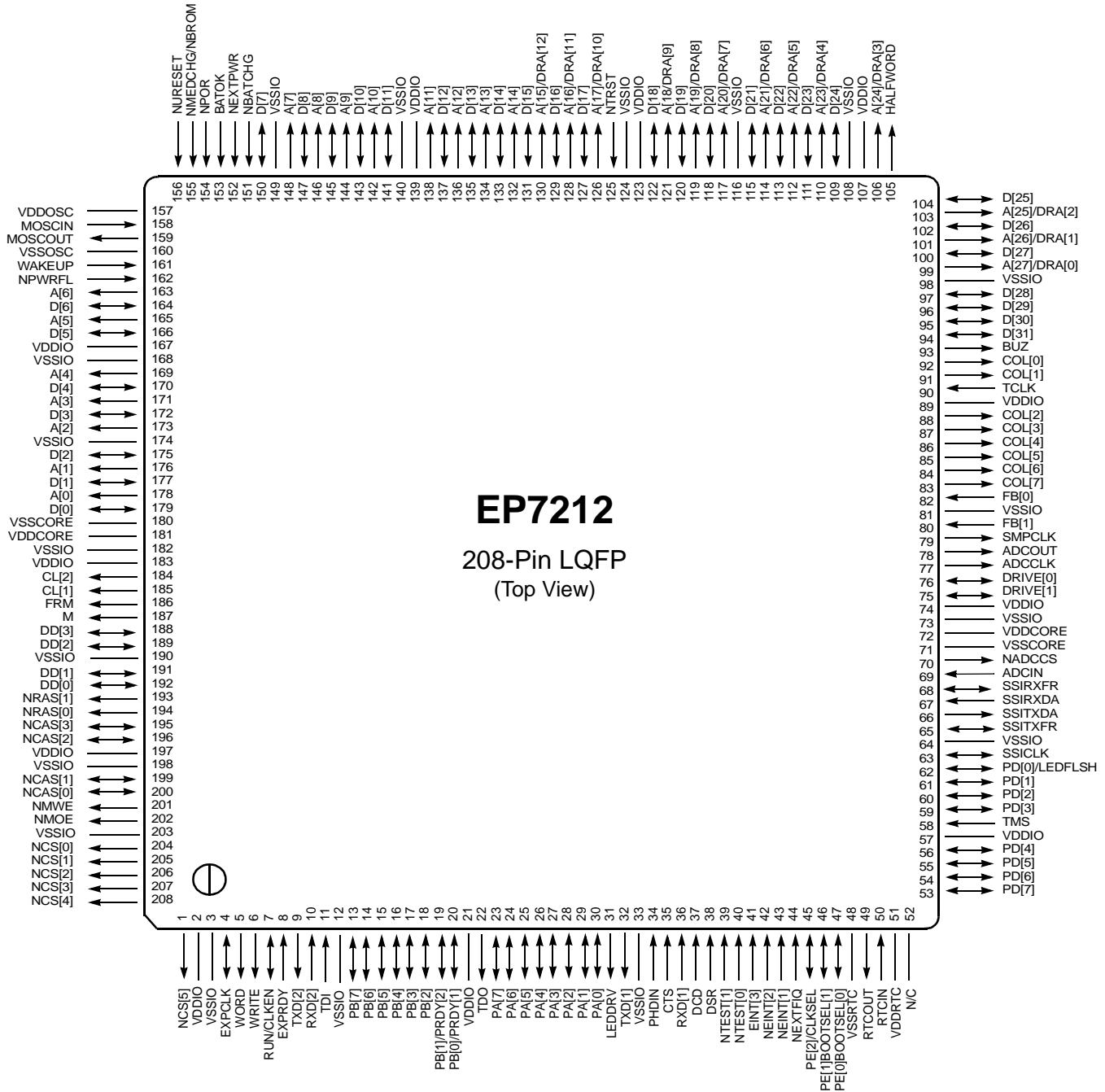

- Notes:
- 1) For package specifications, please see *208-Pin LQFP Package Outline Drawing* on page 125
  - 2) N/C should not be grounded but left as no connects

Figure 27. 208-Pin LQFP (Low Profile Quad Flat Pack) Pin Diagram

**8.2 208-Pin LQFP Numeric Pin Listing**

Pin No.	Signal	Type	Strength	Reset State
1	nCS[5]	Out	1	High
2	VDDIO	Pad Pwr		
3	VSSIO	Pad Gnd		
4	EXPCLK	I/O	1	
5	WORD	Out	1	Low
6	WRITE	Out	1	Low
7	RUN/CLKEN	I/O	1	Low
8	EXPRDY	In	1	
9	TXD[2]	Out	1	High
10	RXD[2]	In		
11	TDI	In	with p/u*	
12	VSSIO	Pad Gnd		
13	PB[7]	I/O	1	Input
14	PB[6]	I/O	1	Input
15	PB[5]	I/O	1	Input
16	PB[4]	I/O	1	Input
17	PB[3]	I/O	1	Input
18	PB[2]	I/O	1	Input
19	PB[1]/ PRDY2	I/O	1	Input
20	PB[0]/ PRDY1	I/O	1	Input
21	VDDIO	Pad Pwr		
22	TDO	Out	1	Tristate
23	PA[7]	I/O	1	Input
24	PA[6]	I/O	1	Input
25	PA[5]	I/O	1	Input
26	PA[4]	I/O	1	Input
27	PA[3]	I/O	1	Input
28	PA[2]	I/O	1	Input
29	PA[1]	I/O	1	Input
30	PA[0]	I/O	1	Input
31	LEDDR	Out	1	Low
32	TXD[1]	Out	1	High
33	VSSIO	Pad Gnd	1	High
34	PHDIN	In		
35	CTS	In		
36	RXD[1]	In		
37	DCD	In		

**Table 65. 208-Pin LQFP Numeric Pin Listing**

Pin No.	Signal	Type	Strength	Reset State
38	DSR	In		
39	nTEST[1]	In	With p/u*	
40	nTEST[0]	In	With p/u*	
41	EINT[3]	In		
42	nEINT[2]	In		
43	nEINT[1]	In		
44	nEXTFIQ	In		
45	PE[2]/ CLKSEL	I/O	1	Input
46	PE[1]/ BOOTSEL[1]	I/O	1	Input
47	PE[0]/ BOOTSEL[0]	I/O	1	Input
48	VSSRTC	RTC Gnd		
49	RTCCOUT	Out		
50	RTCCIN	In		
51	VDDRTC	RTC power		
52	N/C			
53	PD[7]	I/O	1	Low
54	PD[6]	I/O	1	Low
55	PD[5]	I/O	1	Low
56	PD[4]	I/O	1	Low
57	VDDIO	Pad Pwr		
58	TMS	In	with p/u*	
59	PD[3]	I/O	1	Low
60	PD[2]	I/O	1	Low
61	PD[1]	I/O	1	Low
62	PD[0]/ LEDFLSH	I/O	1	Low
63	SSICLK	I/O	1	Input
64	VSSIO	Pad Gnd		
65	SSITXFR	I/O	1	Low
66	SSITXDA	Out	1	Low
67	SSIRXDA	In		
68	SSIRXFR	I/O		Input
69	ADCIN	In		
70	nADCCS	Out	1	High
71	VSSCORE	Core Gnd		

**Table 65. 208-Pin LQFP Numeric Pin Listing (cont.)**

Pin No.	Signal	Type	Strength	Reset State
72	VDDCORE	Core Pwr		
73	VSSIO	Pad Gnd		
74	VDDIO	Pad Pwr		
75	DRIVE[1]	I/O	2	High / Low
76	DRIVE[0]	I/O	2	High / Low
77	ADCCLK	Out	1	Low
78	ADCOUT	Out	1	Low
79	SMPCLK	Out	1	Low
80	FB[1]	In		
81	VSSIO	Pad Gnd		
82	FB[0]	In		
83	COL[7]	Out	1	High
84	COL[6]	Out	1	High
85	COL[5]	Out	1	High
86	COL[4]	Out	1	High
87	COL[3]	Out	1	High
88	COL[2]	Out	1	High
89	VDDIO	Pad Pwr		
90	TCLK	In		
91	COL[1]	Out	1	High
92	COL[0]	Out	1	High
93	BUZ	Out	1	Low
94	D[31]	I/O	1	Low
95	D[30]	I/O	1	Low
96	D[29]	I/O	1	Low
97	D[28]	I/O	1	Low
98	VSSIO	Pad Gnd		
99	A[27]/DRA[0]	Out	2	Low
100	D[27]	I/O	1	Low
101	A[26]/DRA[1]	Out	2	Low
102	D[26]	I/O	1	Low
103	A[25]/DRA[2]	Out	2	Low
104	D[25]	I/O	1	Low
105	HALFWORD	Out	1	Low
106	A[24]/DRA[3]	Out	1	Low
107	VDDIO	Pad Pwr		—
108	VSSIO	Pad Gnd		—
109	D[24]	I/O	1	Low

**Table 65. 208-Pin LQFP Numeric Pin Listing (cont.)**

Pin No.	Signal	Type	Strength	Reset State
110	A[23]/DRA[4]	Out	1	Low
111	D[23]	I/O	1	Low
112	A[22]/DRA[5]	Out	1	Low
113	D[22]	I/O	1	Low
114	A[21]/DRA[6]	Out	1	Low
115	D[21]	I/O	1	Low
116	VSSIO	Pad Gnd		
117	A[20]/DRA[7]	Out	1	Low
118	D[20]	I/O	1	Low
119	A[19]/DRA[8]	Out	1	Low
120	D[19]	I/O	1	Low
121	A[18]/DRA[9]	Out	1	Low
122	D[18]	I/O	1	Low
123	VDDIO	Pad Pwr		
124	VSSIO	Pad Gnd		
125	nTRST	In		
126	A[17]/DRA[10]	Out	1	Low
127	D[17]	I/O	1	Low
128	A[16]/DRA[11]	Out	1	Low
129	D[16]	I/O	1	Low
130	A[15]/DRA[12]	Out	1	Low
131	D[15]	I/O	1	Low
132	A[14]	Out	1	Low
133	D[14]	I/O	1	Low
134	A[13]	Out	1	Low
135	D[13]	I/O	1	Low
136	A[12]	Out	1	Low
137	D[12]	I/O	1	Low
138	A[11]	Out	1	Low
139	VDDIO	Pad Pwr		
140	VSSIO	Pad Gnd		
141	D[11]	I/O	1	Low
142	A[10]	Out	1	Low
143	D[10]	I/O	1	Low
144	A[9]	Out	1	Low
145	D[9]	I/O	1	Low
146	A[8]	Out	1	Low
147	D[8]	I/O	1	Low
148	A[7]	Out	1	Low
149	VSSIO	Pad Gnd		

**Table 65. 208-Pin LQFP Numeric Pin Listing (cont.)**

Pin No.	Signal	Type	Strength	Reset State
150	D[7]	I/O	1	Low
151	nBATCHG	In		
152	nEXTPWR	In		
153	BATOK	In		
154	nPOR	In	Schmitt	
155	nMEDCHG/ nBROM	In		
156	nURESET	In	Schmitt	
157	VDDOSC	Osc Pwr		
158	MOSCIN	Osc		
159	MOSCOU	Osc		
160	VSSOSC	Osc Gnd		
161	WAKEUP	In	Schmitt	
162	nPWRFL	In		
163	A[6]	Out	1	Low
164	D[6]	I/O	1	Low
165	A[5]	Out	1	Low
166	D[5]	I/O	1	Low
167	VDDIO	Pad Pwr		
168	VSSIO	Pad Gnd		
169	A[4]	Out	1	Low
170	D[4]	I/O	1	Low
171	A[3]	Out	2	Low
172	D[3]	I/O	1	Low
173	A[2]	Out	2	Low
174	VSSIO	Pad Gnd		
175	D[2]	I/O	1	Low
176	A[1]	Out	2	Low
177	D[1]	I/O	1	Low
178	A[0]	Out	2	Low
179	D[0]	I/O	1	Low
180	VSS CORE	Core Gnd		
181	VDD CORE	Core Pwr		
182	VSSIO	Pad Gnd		
183	VDDIO	Pad Pwr		
184	CL[2]	Out	1	Low
185	CL[1]	Out	1	Low
186	FRM	Out	1	Low
187	M	Out	1	Low

**Table 65. 208-Pin LQFP Numeric Pin Listing (cont.)**

Pin No.	Signal	Type	Strength	Reset State
188	DD[3]	I/O	1	Low
189	DD[2]	I/O	1	Low
190	VSSIO	Pad Gnd		
191	DD[1]	I/O	1	Low
192	DD[0]	I/O	1	Low
193	nRAS[1]	Out	1	High
194	nRAS[0]	Out	1	High
195	nCAS[3]	I/O	2	High
196	nCAS[2]	I/O	2	High
197	VDDIO	Pad Pwr		
198	VSSIO	Pad Gnd		
199	nCAS[1]	I/O	2	High
200	nCAS[0]	I/O	2	High
201	nMWE	Out	1	High
202	nMOE	Out	1	High
203	VSSIO	Pad Gnd		
204	nCS[0]	Out	1	High
205	nCS[1]	Out	1	High
206	nCS[2]	Out	1	High
207	nCS[3]	Out	1	High
208	nCS[4]	Out	1	High

**NOTE:** ‘With p/u’ means with internal pull-up on the pin.

**Table 65. 208-Pin LQFP Numeric Pin Listing (cont.)**



8.3 256-Pin PBGA Pin Diagram

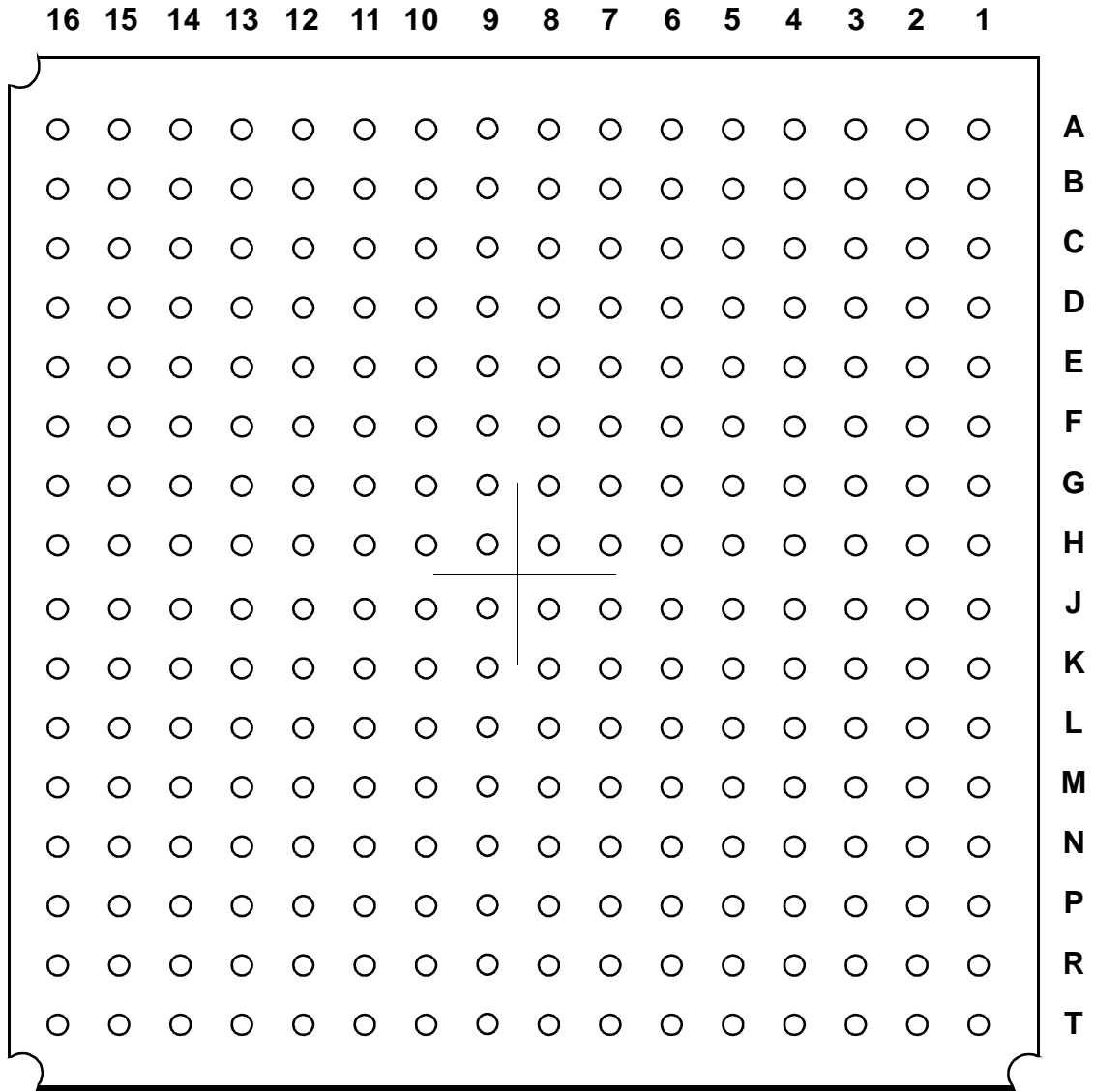

256-Ball PBGA  
(Bottom View)

**NOTE:** For package specifications, please see *256-Ball PBGA Dimensions* page 126

**8.4 256-Ball PBGA Ball Listing**

Ball Location	Name	Type
A1	VDDIO	Pad power
A2	nCS[4]	O
A3	nCS[1]	O
A4	nCAS[0]	O
A5	nCAS[3]	O
A6	DD[1]	O
A7	M	O
A8	VDDIO	Pad power
A9	D[0]	I/O
A10	D[2]	I/O
A11	A[3]	O
A12	VDDIO	Pad power
A13	A[6]	O
A14	MOSCOUT	O
A15	VDDOSC	Oscillator power
A16	VSSIO	Pad ground
B1	nCS[5]	O
B2	VDDIO	Pad power
B3	nCS[3]	O
B4	nMOE	O
B5	VDDIO	Pad power
B6	nRAS[1]	O
B7	DD[2]	O
B8	CL[1]	O
B9	VDDCORE	Core power
B10	D[1]	I/O
B11	A[2]	O
B12	A[4]	O
B13	A[5]	O
B14	WAKEUP	I
B15	VDDIO	Pad power
B16	nURESET	I
C1	VDDIO	Pad power
C2	EXPCLK	I
C3	VSSIO	Pad ground
C4	VDDIO	Pad power
C5	VSSIO	Pad ground
C6	VSSIO	Pad ground

**Table 66. 256-Ball PBGA Ball Listing**

Ball Location	Name	Type
C7	VSSIO	Pad ground
C8	VDDIO	Pad power
C9	VSSIO	Pad ground
C10	VSSIO	Pad ground
C11	VSSIO	Pad ground
C12	VDDIO	Pad power
C13	VSSIO	Pad ground
C14	VSSIO	Pad ground
C15	nPOR	I
C16	nEXTPWR	I
D1	WRITE	O
D2	EXPRDY	I
D3	VSSIO	Pad ground
D4	VDDIO	Pad power
D5	nCS[2]	O
D6	nMWE	O
D7	nRAS[1]	O
D8	CL[2]	O
D9	VSSRTC	Core ground
D10	D[4]	I/O
D11	nPWRFL	I
D12	MOSCIN	I
D13	VDDIO	Pad power
D14	VSSIO	Pad ground
D15	D[7]	I/O
D16	D[8]	I/O
E1	RXD[2]	I
E2	PB[7]	I
E3	TDI	I
E4	WORD	O
E5	VSSIO	Pad ground
E6	nCS[0]	O
E7	nCAS[2]	O
E8	FRM	O
E9	A[0]	O
E10	D[5]	I/O
E11	VSSOSC	Oscillator ground
E12	VSSIO	Pad ground
E13	nMEDCHG/nBROM	I

**Table 66. 256-Ball PBGA Ball Listing (cont.)**

Ball Location	Name	Type
E14	VDDIO	Pad power
E15	D[9]	I/O
E16	D[10]	I/O
F1	PB[5]	I
F2	PB[3]	I
F3	VSSIO	Pad ground
F4	TXD[2]	O
F5	RUN/CLKEN	O
F6	VSSIO	Pad ground
F7	nCAS[1]	O
F8	DD[3]	O
F9	A[1]	O
F10	D[6]	I/O
F11	VSSRTC	RTC ground
F12	BATOK	I
F13	nBATCHG	I
F14	VSSIO	Pad ground
F15	D[11]	I/O
F16	VDDIO	Pad power
G1	PB[1]/PRDY[2]	I
G2	VDDIO	Pad power
G3	TDO	O
G4	PB[4]	I
G5	PB[6]	I
G6	VSSRTC	Core ground
G7	VSSRTC	RTC ground
G8	DD[0]	O
G9	D[3]	I/O
G10	VSSRTC	RTC ground
G11	A[7]	O
G12	A[8]	O
G13	A[9]	O
G14	VSSIO	Pad ground
G15	D[12]	I/O
G16	D[13]	I/O
H1	PA[7]	I
H2	PA[5]	I
H3	VSSIO	Pad ground
H4	PA[4]	I
H5	PA[6]	I

**Table 66. 256-Ball PBGA Ball Listing (cont.)**

Ball Location	Name	Type
H6	PB[0]/PRDY[1]	I
H7	PB[2]	I
H8	VSSRTC	RTC ground
H9	VSSRTC	RTC ground
H10	A[10]	O
H11	A[11]	O
H12	A[12]	O
H13	A[13]	O
H14	VSSIO	Pad ground
H15	D[14]	I/O
H16	D[15]	I/O
J1	PA[3]	I
J2	PA[1]	I
J3	VSSIO	Pad ground
J4	PA[2]	I
J5	PA[0]	I
J6	TXD[1]	O
J7	CTS	I
J8	VSSRTC	RTC ground
J9	VSSRTC	RTC ground
J10	A[17]/DRA[10]	O
J11	A[16]/DRA[11]	O
J12	A[15]/DRA[12]	O
J13	A[14]	O
J14	nTRST	I
J15	D[16]	I/O
J16	D[17]	I/O
K1	LEDDR	O
K2	PHDIN	I
K3	VSSIO	Pad ground
K4	DCD	I
K5	nTEST[1]	I
K6	EINT[3]	I
K7	VSSRTC	RTC ground
K8	ADCIN	I
K9	COL[4]	O
K10	TCLK	I
K11	D[20]	I/O
K12	D[19]	I/O
K13	D[18]	I/O

**Table 66. 256-Ball PBGA Ball Listing (cont.)**

Ball Location	Name	Type
K14	VSSIO	Pad ground
K15	VDDIO	Pad power
K16	VDDIO	Pad power
L1	RXD[1]	I
L2	DSR	I
L3	VDDIO	Pad power
L4	nEINT[1]	I
L5	PE[2]/CLKSEL	I
L6	VSSRTC	RTC ground
L7	PD[0]/LEDFLSH	I/O
L8	VSSRTC	Core ground
L9	COL[6]	O
L10	D[31]	I/O
L11	VSSRTC	RTC ground
L12	A[22]/DRA[5]	O
L13	A[21]/DRA[6]	O
L14	VSSIO	Pad ground
L15	A[18]/DRA[9]	O
L16	A[19]/DRA[8]	O
M1	nTEST[0]	I
M2	nEINT[2]	I
M3	VDDIO	Pad power
M4	PE[0]/BOOTSEL[0]	I
M5	TMS	I
M6	VDDIO	Pad power
M7	SSITXFR	I/O
M8	DRIVE[1]	I/O
M9	FB[0]	I
M10	COL[0]	O
M11	D[27]	I/O
M12	VSSIO	Pad ground
M13	A[23]/DRA[4]	O
M14	VDDIO	Pad power
M15	A[20]/DRA[7]	O
M16	D[21]	I/O
N1	nEXTFIQ	I
N2	PE[1]/BOOTSEL[1]	I
N3	VSSIO	Pad ground
N4	VDDIO	Pad power
N5	PD[5]	I/O

**Table 66. 256-Ball PBGA Ball Listing (cont.)**

Ball Location	Name	Type
N6	PD[2]	I/O
N7	SSIRXDA	I/O
N8	ADCCLK	O
N9	SMPCLK	O
N10	COL[2]	O
N11	D[29]	I/O
N12	D[26]	I/O
N13	HALFWORD	O
N14	VSSIO	Pad ground
N15	D[22]	I/O
N16	D[23]	I/O
P1	VSSRTC	RTC ground
P2	RTCCOUT	O
P3	VSSIO	Pad ground
P4	VSSIO	Pad ground
P5	VDDIO	Pad power
P6	VSSIO	Pad ground
P7	VSSIO	Pad ground
P8	VDDIO	Pad power
P9	VSSIO	Pad ground
P10	VDDIO	Pad power
P11	VSSIO	Pad ground
P12	VSSIO	Pad ground
P13	VDDIO	Pad power
P14	VSSIO	Pad ground
P15	D[24]	I/O
P16	VDDIO	Pad power
R1	RTCCIN	I/O
R2	VDDIO	Pad power
R3	PD[4]	I/O
R4	PD[1]	I/O
R5	SSITXDA	O
R6	nADCCS	O
R7	VDDIO	Pad power
R8	ADCOUT	O
R9	COL[7]	O
R10	COL[3]	O
R11	COL[1]	O
R12	D[30]	I/O
R13	A[27]/DRA[0]	O

**Table 66. 256-Ball PBGA Ball Listing (cont.)**

Ball Location	Name	Type
R14	A[25]/DRA[2]	O
R15	VDDIO	Pad power
R16	A[24]/DRA[3]	O
T1	VDDRTC	RTC power
T2	PD[7]	I/O
T3	PD[6]	I/O
T4	PD[3]	I/O
T5	SSICLK	I/O
T6	SSIRXFR	-
T7	VDDCORE	Core power
T8	DRIVE[0]	I/O
T9	FB[1]	I
T10	COL[5]	O
T11	VDDIO	Pad power
T12	BUZ	O
T13	D[28]	I/O
T14	A[26]/DRA[1]	O
T15	D[25]	I/O
T16	VSSIO	Pad ground

**Table 66. 256-Ball PBGA Ball Listing (cont.)**

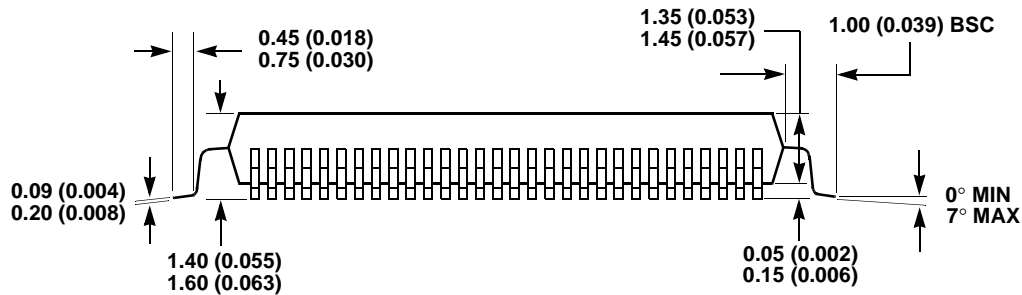
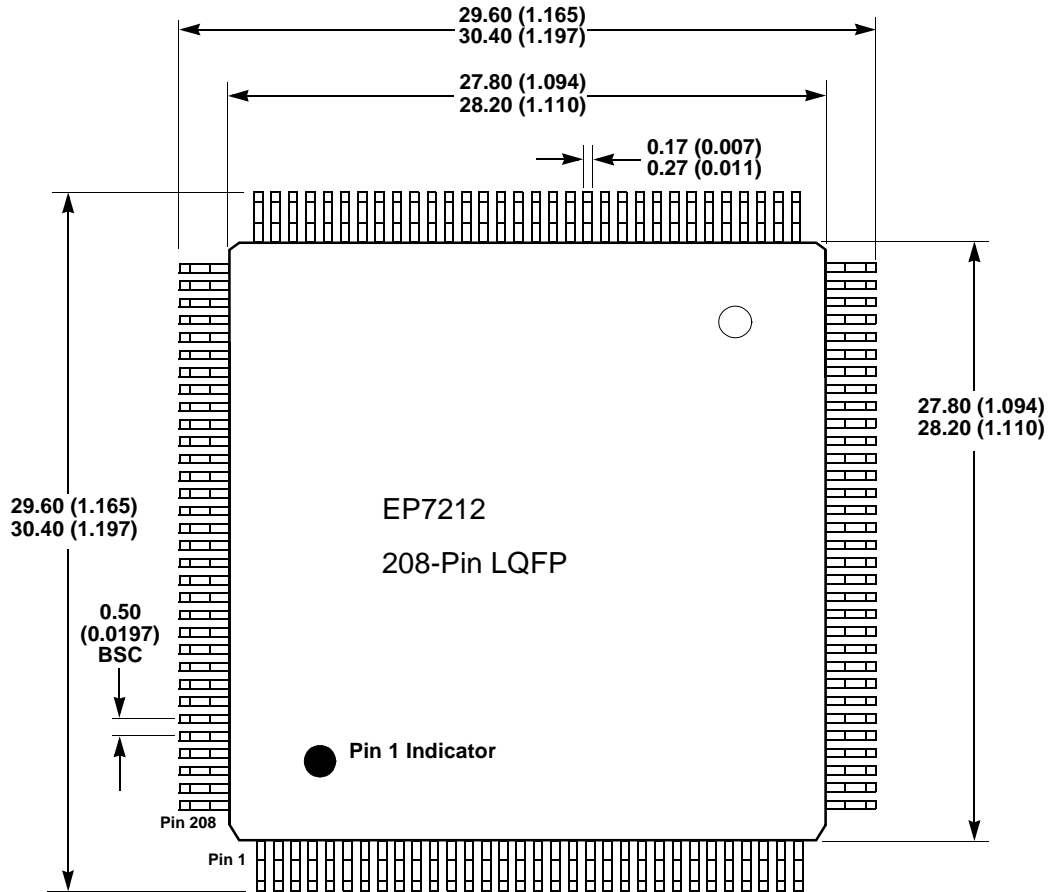
**9. PACKAGE SPECIFICATIONS**
**9.1 208-Pin LQFP Package Outline Drawing**

- NOTES:**
- 1) Dimensions are in millimeters (inches), and controlling dimension is millimeter.
  - 2) Drawing above does not reflect exact package pin count.
  - 3) Before beginning any new design with this device, please contact Cirrus Logic for the latest package information.
  - 4) For pin description, please see *208-Pin LQFP Pin Diagram* page 13





10. ORDERING INFORMATION

The order number for the device is:

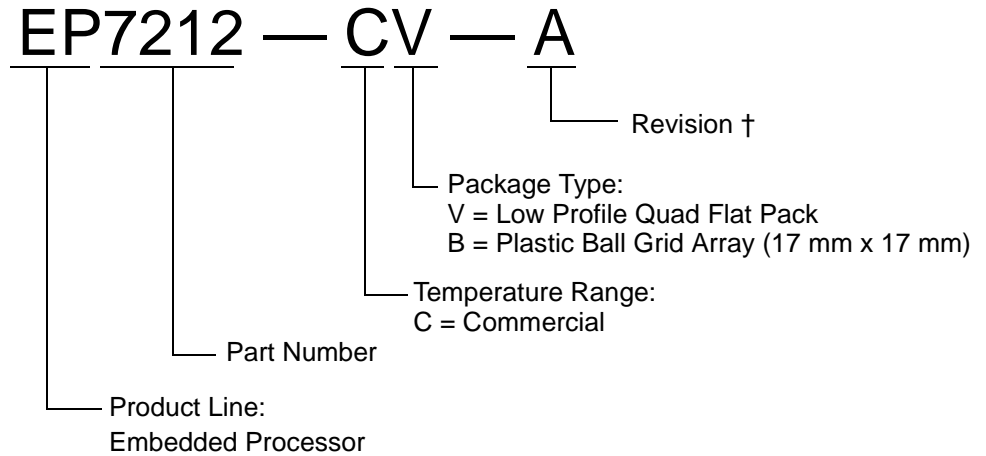

**NOTE:** † Contact Cirrus Logic for up-to-date information on revisions. Go to the Cirrus Logic Internet site at <http://cirrus.com/corporate/contacts> to find contact information for your local sales representative.



11. APPENDIX A: BOOT CODE

;(C) Copyright 1995-1996, Cirrus Logic, Inc. All Rights Reserved.

;
TTL CL-EP7212 Sample program
; version 1.0 (initial version);ks
; boot from uart1

AREA |C\$\$code|, CODE, READONLY

ENTRY

; System constants

;
HwBaseAddress EQU 0x80000000
;
;
HwControl EQU 0x00000100
HwControl2 EQU 0x00001100
HwControlUartEnable EQU 0x00000100
;
HwStatus EQU 0x00000140
HwStatus2 EQU 0x000001140
HwStatusUartRxFifoEmpty EQU 0x00400000
;
HwUartData EQU 0x00000480
HwUartData2 EQU 0x00001480
HwUartDataFrameErr EQU 0x0100
HwUartDataParityErr EQU 0x0200
HwUartDataOverrunErr EQU 0x0400
HwUartControl EQU 0x000004C0
HwUartControl2 EQU 0x000014C0
HwUartControlRate EQU 0x00000FFF
HwUartControlRate115200 EQU 0x001
HwUartControlRate76800 EQU 0x002
HwUartControlRate57600 EQU 0x003
HwUartControlRate38400 EQU 0x005

---

```

HwUartControlRate19200      EQU      0x00B
HwUartControlRate14400      EQU      0x00F
HwUartControlRate9600       EQU      0x017
HwUartControlRate4800       EQU      0x02F
HwUartControlRate2400       EQU      0x05F
HwUartControlRate1200       EQU      0x0BF
HwUartControlRate600        EQU      0x17F
HwUartControlRate300        EQU      0x2FF
HwUartControlRate150        EQU      0x5FF
HwUartControlRate110        EQU      0x82E
HwUartControlRate115200_13  EQU      0x000
HwUartControlRate57600_13   EQU      0x001
HwUartControlRate38400_13   EQU      0x002
HwUartControlRate19200_13   EQU      0x005
HwUartControlRate14400_13   EQU      0x007
HwUartControlRate9600_13    EQU      0x00b
HwUartControlRate4800_13    EQU      0x017
HwUartControlRate2400_13    EQU      0x02F
HwUartControlRate1200_13    EQU      0x060
HwUartControlRate600_13     EQU      0x0c0
HwUartControlRate300_13     EQU      0x182
HwUartControlRate150_13     EQU      0x305
HwUartControlRate110_13     EQU      0x41E
HwUartControlBreak          EQU      0x00001000
HwUartControlParityEnable    EQU      0x00002000
HwUartControlPartiyEvenOrOdd EQU      0x00004000
HwUartControlTwoStopBits     EQU      0x00008000
HwUartControlFifoEnable      EQU      0x00010000
HwUartControlDataLength      EQU      0x00060000
HwUartControlDataLength5     EQU      0x00000000
HwUartControlDataLength6     EQU      0x00020000
HwUartControlDataLength7     EQU      0x00040000
HwUartControlDataLength8     EQU      0x00060000
;
;      9600baud, 8bits/ch no parity, 1 stop bit
UartValue      EQU      HwUartControlRate9600+HwUartControlDataLength8
UartValue_13   EQU      HwUartControlRate9600_13+HwUartControlDataLength8
BufferAddress   EQU      0x10000000      ;start address sram snooze buffer
codeexeaddr     EQU      0x10000000      ;
count          EQU      0x00000800      ;2k bytes

```

```

startflag      EQU      '<'
endflag        EQU      '>'
CLKMOD         EQU      0x40          ;clock mode 1 = 13 MHz

;          ARM Processor constants

ArmIrqDisable      EQU      0x00000080
ArmFiqDisable      EQU      0x00000040

; 26bit mode is not supported
;
ArmUserMode        EQU      0x10
ArmFIQMode         EQU      0x11
ArmIRQMode         EQU      0x12
ArmSVCMMode        EQU      0x13
ArmAbortMode       EQU      0x17
ArmUndefMode       EQU      0x1B
ArmMaskMode        EQU      0x1F
;
ArmMmuCP           CP       0xF
;
ArmMmuId           CN       0x00
;
ArmMmuControl      CN       0x01
ArmMmuControlMmuEnable      EQU      0x00000001
ArmMmuControlAlignFaultEnable EQU      0x00000002
ArmMmuControlCacheEnable    EQU      0x00000004
ArmMmuControlWriteBufferEnable EQU      0x00000008
ArmMmuControl32BitCodeEnable EQU      0x00000010
ArmMmuControl32BitDataEnable EQU      0x00000020
ArmMmuControlMandatory      EQU      0x00000040
ArmMmuControlBigEndianEnable EQU      0x00000080
ArmMmuControlSystemEnable   EQU      0x00000100
ArmMmuControlRomEnable      EQU      0x00000200
;
ArmMmuPageTableBase  CN      0x02
;
ArmMmuDomainAccess  CN      0x03
;
ArmMmuFlushTlb      CN      0x05

```

```

;
ArmMmuPurgeTlb          CN          0x06
;
ArmMmuFlushIdc         CN          0x07

;InitialMmuConfig      EQU          ArmMmuControl32BitCodeEnable
+ArmMmuControl32BitDataEnable          +ArmMmuControlMandatory
+ArmMmuControlBigEndianEnable

InitialMmuConfig        EQU          ArmMmuControl32BitCodeEnable
+ArmMmuControl32BitDataEnable +ArmMmuControlMandatory ;leave as little endian
11/6/96 ks

;=====
=====
;          REAL CODE START

;          set little endian, 32bit code, 32bit data by writing to CP15's control
register

        LDR    r0, =InitialMmuConfig
        MCR    ArmMmuCP, 0, r0, ArmMmuControl, c0

;          set the cpu to SVC32 mode

        MRS    r0, CPSR          ;read psr
        BIC    r0, r0, #ArmMaskMode ;remove the mode bits
        ORR    r0, r0, #ArmSVCMode ;set to supervisor 32 bit mode
        MSR    CPSR, r0          ; Now set the CPU into the new mode
;

;          initialize HW control
UARTEnable
        LDR    r12, =HwBaseAddress
        MOV    r0, #HwControlUartEnable ;Enable UART
        STR    r0, [r12, #HwControl]
        LDR    r1, =HwStatus2
        ADD    r1, r1, r12
        LDR    r2, [r1]          ;read system flag2
        TST    r2, #CLKMOD
        LDREQ  r0, =UartValue    ;load 18 mhz value if bit not set
        LDRNE  r0, =UartValue_13 ;load 13 mhz value if bit set

```

```
        STR    r0,[r12,#HwUartControl]        ;initialise Uart

;        Send ready signal
        LDR    r0,=startflag
        STRB   r0,[r12,#HwUartData]          ; send ready

;        receive the data
        LDR    r3,=count
        LDR    r2,=BufferAddress

01
;        wait for byte available
        LDR    r1,[r12,#HwStatus]            ; spin, if Rx FIFO is empty
        TST   r1,#HwStatusUartRxFifoEmpty
        BNE   %b01

;        read the data ,store it and accumulate checksum
        LDRB   r0,[r12,#HwUartData]          ; read data
        STRB   r0,[r2],#1                    ; save it in memory
        SUBS   r3,r3,#1                      ; decrement count
        BNE   %b01                          ; do more if count has not expired

;        all received, send end flag
        LDR    r0,=endflag
        STRB   r0,[r12,#HwUartData]          ; send reply
        LDR    r15,=codeexeaddr              ;jump to execution address

        LTORG

        END
```

## 12. INDEX

### Symbols

/BOOTSEL0 17  
/BOOTSEL1 17  
/CLKSEL 17  
/LEDFLSH 16  
/PRDY1 17  
/PRDY2 PB 17

### Alphabetical

#### B

boundary scan 50

#### C

clocks 25  
    external clock input (13 MHz) 26  
    on-chip PLL 25  
CPU core 20

#### D

dedicated LED flasher 49  
DRAM controller with EDO support 31

#### E

endianness 36

#### F

functional block diagram 20  
functional description 19

#### I

idle state 29  
Internal UARTs 36  
in-circuit emulation 50  
interrupt Controller 24

#### L

LCD controller 46

#### M

memory and I/O expansion interface 30  
    EP7211 boot ROM 29

#### O

operating state 27

#### P

PADDR Port A Data Direction Register 58  
PADR Port A Data Register 57

PBDR Port B Data Register 57  
PDDDR Port D Data Direction Register 58  
PDDR Port D Data Register 57  
PEDDR Port E Data Direction Register 58  
pin descriptions, external signal functions 14  
pin diagram 13, 116  
pin information  
    A 14  
    ADCCLK 16  
    ADCIN 16  
    ADCOUT 16  
    BATOK 15  
    BUZ 16  
    CL1 16  
    CL2 16  
    COL 16  
    CTS 16  
    D 14  
    DCD 16  
    DD 16  
    DRA 14  
    DRIVE 17  
    DSR 16  
    EINT3 15  
    EXPCLK 14  
    EXPRDY 14  
    FB 17  
    FRM 16  
    LEDDRV 16  
    M 16  
    MOSCIN 17  
    MOSCOU 17  
    NADCCS 16  
    NBATCHG 15  
    NCS 14  
    NEINT 15  
    NEXTFIQ 15  
    NEXTPWR 15  
    NMEDCHG/ BROM 15  
    NMOE 14  
    NPOR 15  
    NPWRFL 15  
    NTEST 17  
    NURESET 15  
    PA 17  
    PB17  
    PB 17  
    PD 16, 17  
    PE 17  
    PHDIN 16  
    RTCIN 17  
    RTCOU 17  
    RUN/CLKEN 15

RXD 16  
SMPCLK 16  
SSICLK 16  
SSIRXDA 16  
SSIRXFR 16  
SSITXDA 16  
SSITXFR 16  
TCLK 17  
TDI 17  
TDO 17  
TMS 17  
TNRST 17  
TXD 16  
WAKEUP 15  
WRITE 14  
PWM interface 49

**R**

real-time clock 49  
resets 24

**S**

serial interface  
ADC Interface 42

clock polarity 46  
continuous data transfer 45  
discontinuous clock 45  
error conditions 46  
MCP interface 40  
MCP operation 41  
readback of residual data 44  
support for asymmetric traffic 45  
serial interfaces 38  
    codec sound interface 39  
SIR encoder 36  
standby state 29  
state control 21  
SYSFLG, The System Status Flags Register 64

**T**

timer counters 47  
    free running mode 48  
    prescale mode 48

**U**

UART 20

• **Notes** •

---

