



ES56030

ECHO SOUND PROCESSOR (8K)

Features

- It includes an internal VCO (Voltage-controlled oscillator for the system clock and can be adjusted to the suitable frequency by using the external resistor and capacitor.)
- It includes an A/D converter (adaptive delta modulation), two low pass filters and a 8k bits SRAM

Application

- KARAOKE
- TV
- Video disc player

FEATURES

ES56030 is an echo effect generator IC. It has an internal VCO circuit to provide the system clock, and it is easily to adjust the suitable frequency with external variable resistor. It has an ADC, DAC and uses digital processing audio signal for the delay time.

ES56030 can be easily used in the karaoke, T.V. and other electronic instruments.

1996.10.14

Function Block Diagram

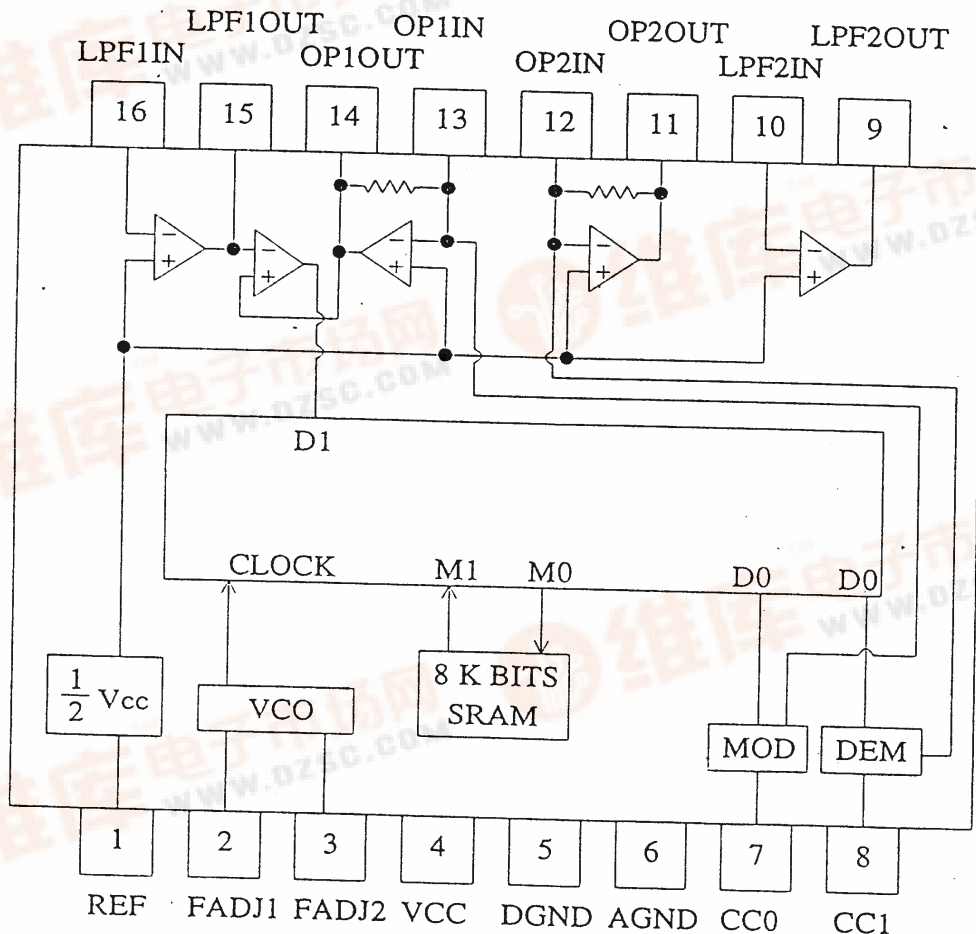

PIN CONFIGURATION

1	REF	LPF1IN	16
2	FADJ1	LPF1OUT	15
3	FADJ1	OP1OUT	14
4	VCC	OP1IN	13
5	DGND	OP2IN	12
6	AGND	OP2OUT	11
7	CC0	LPF2IN	10
8	CC1	LPF2OUT	9

Pin description

PIN DESCRIPTION

Pin	Name	Type	Function
1	REF	I	Reference voltage(=1/2VCC)
2	FADJ1		Frequency_adjust 1
3	FADJ2		Frequency_adjust 1
4	VCC	I	Supply voltage input
5	DGND		Digital ground
6	AGND		Analog ground
7	CC0		Current control 0 Current control 0
8	CC1		Digital supply voltage input
9	FPF2OUT	O	Low pass filter 2 output
10	LPF2IN	I	Low pass filter 2 input
11	OP2OUT	O	It can be used as demodulated integrator by connected capacitor
12	OP2IN	I	It can be used as demodulated integrator by connected capacitor
13	OP1IN	I	It can be used as demodulated integrator by connected capacitor
14	OP1OUT	O	It can be used as demodulated integrator by connected capacitor
15	LPF1OUT	O	Low pass filter 1 output
16	LPF1OUT	O	Low pass filter 1 input

Absolute Maximum Ratings

(Ta=25°C, unless otherwise noted)

Symbol	Description	Limits	Unit
Vcc	Supply voltage	6.5	V
Topr	Supply current	-20~75	°C
Tstg	Storage temperature	-20~125	°C
Pd	Power dissipation	0.9	W

Recommended Operating Conditions

Supply voltage range.....4.5~5.5V

Rated supply voltage.....5V

Electrical Characteristics

(VCC = 5.0V, fin = 1 KHz, Vi = 100 mVrms, Ta = 25°C,
unless otherwise noted)

Symbol	Parameter	Test condition	Min	Typ	Max	Unit
Icc	Supply voltage			4.1	7	Ma
Gv	Gain	Rload = 10KΩ	-2.5	0	2.5	dB
THD	Total harmonic Distortion			2.6	3.0	%
No	Noise			-73	-60	dBV

Operation mode

ES56030 converts an input analog signal to a digital signal and writes it in the memory(8K bits). After a time delay it reads the digital signal from the memory, then it converts to an analog signal again.

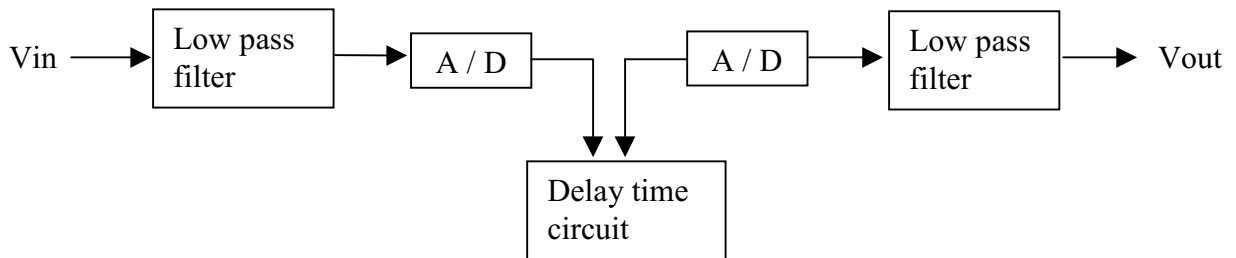

Working frequency(Fw)

$$F_w = \frac{1}{0.811RC} \text{ (Hz)}$$

*Unit : R(Ω) , C(F)

Sampling frequency(Fs)

$$F_s = \frac{1}{4} F_w$$

Echo application circuit

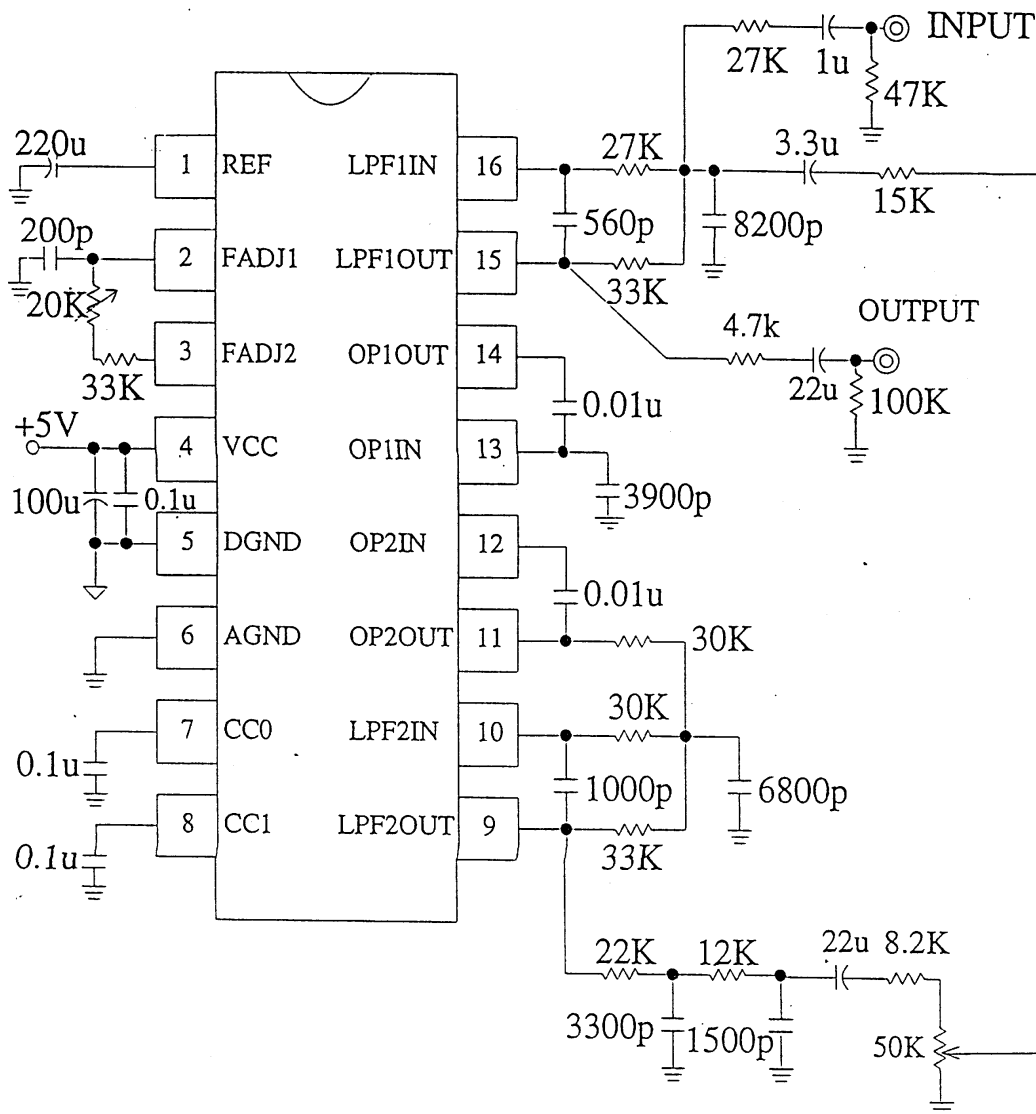

*Note : ES56030's working frequency (Fw) can be measured from the Pin 3 .
And advise ES56030's Fw from 230KHz to 400KHz .

Surround application circuit

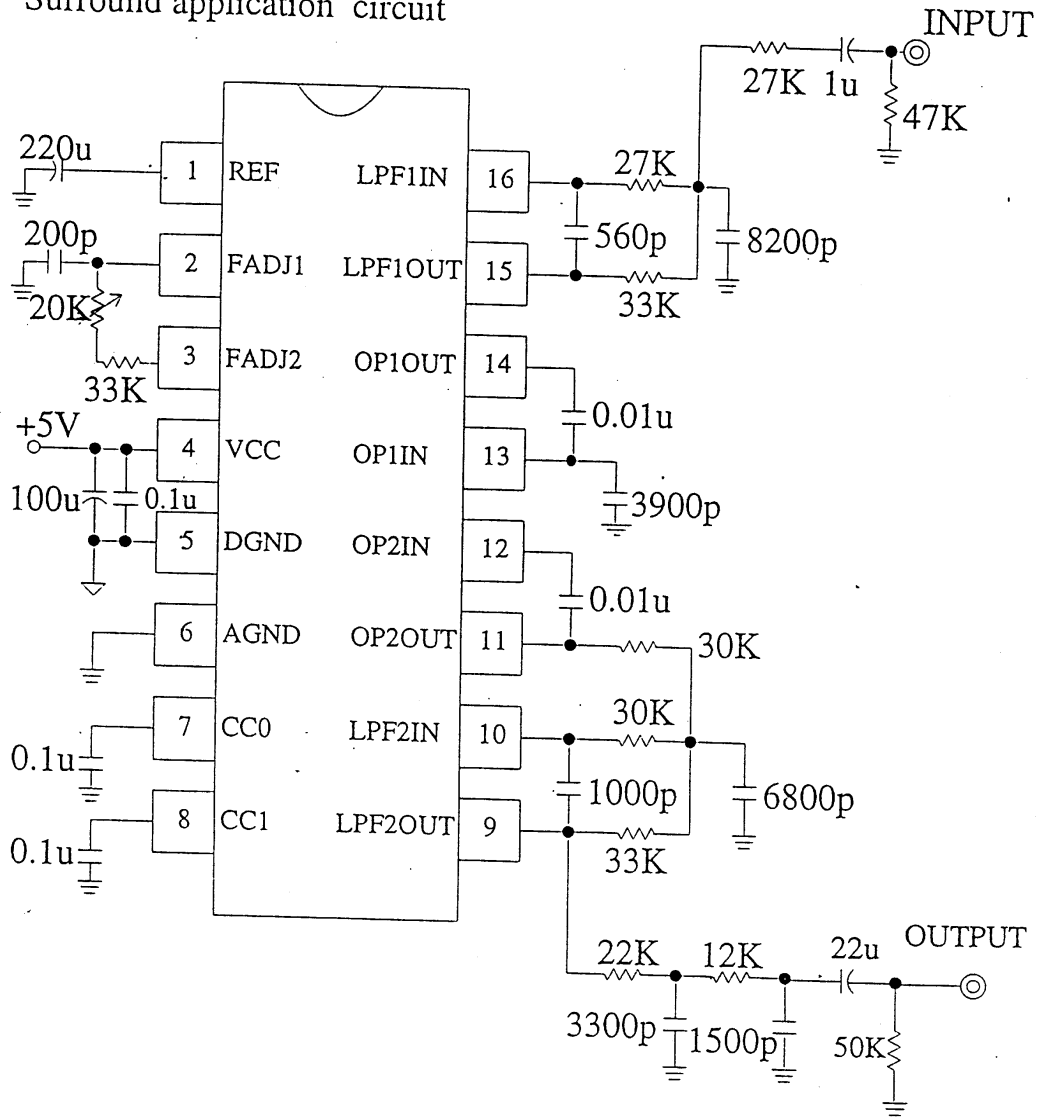

* ECHO application circuit (continued)

MIC Pre-Amp Application circuit

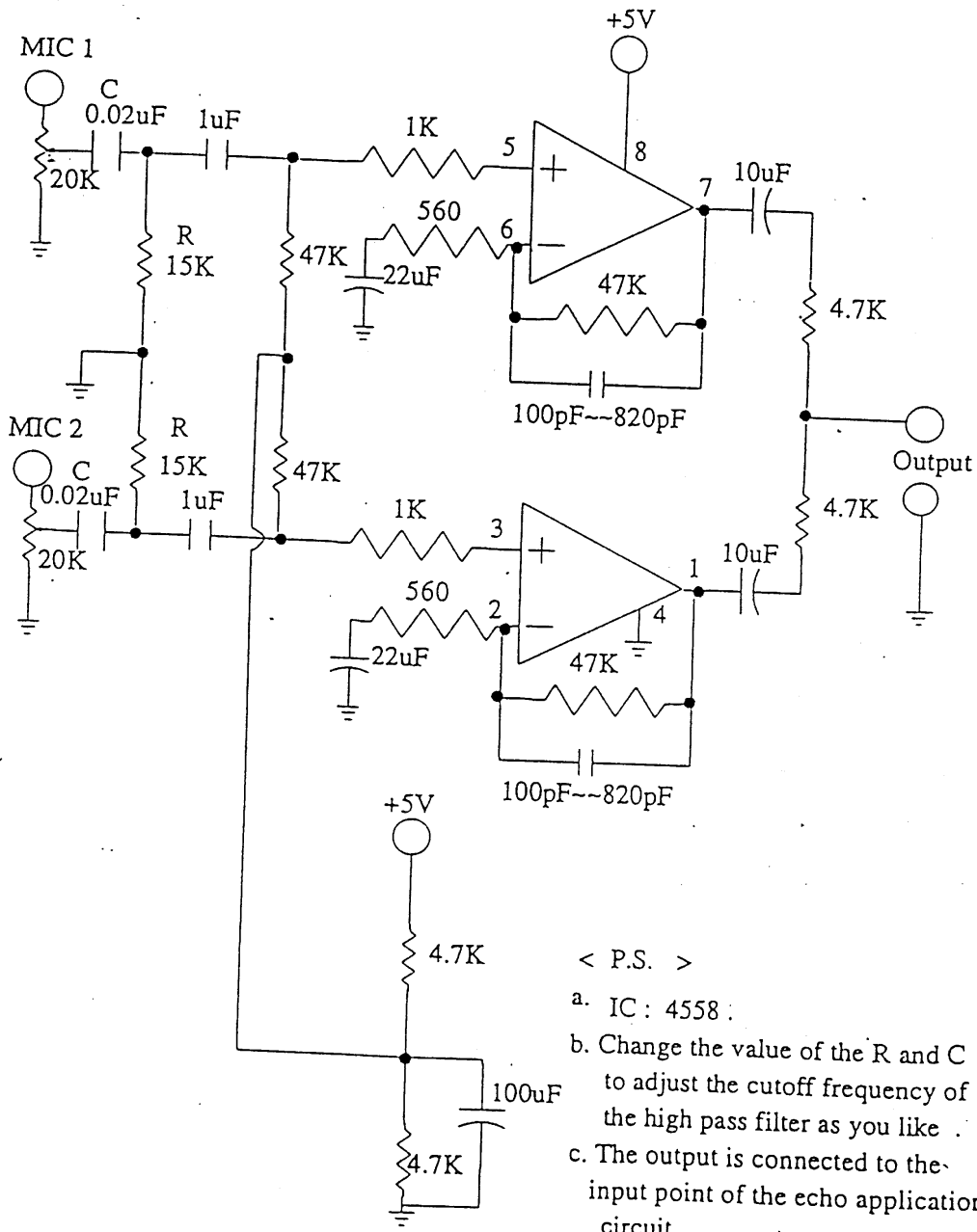

- < P.S. >
- a. IC : 4558 :
 - b. Change the value of the R and C to adjust the cutoff frequency of the high pass filter as you like .
 - c. The output is connected to the input point of the echo application circuit .



Output voltage vs. frequency

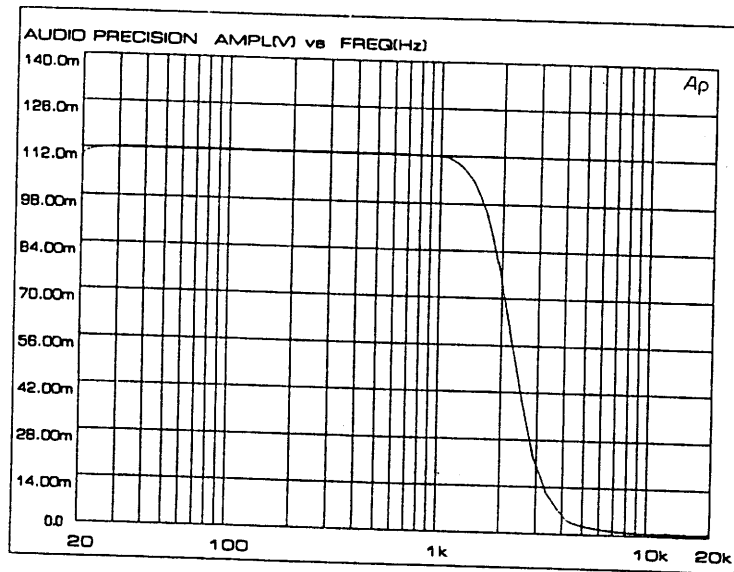

Output THD vs Input voltage

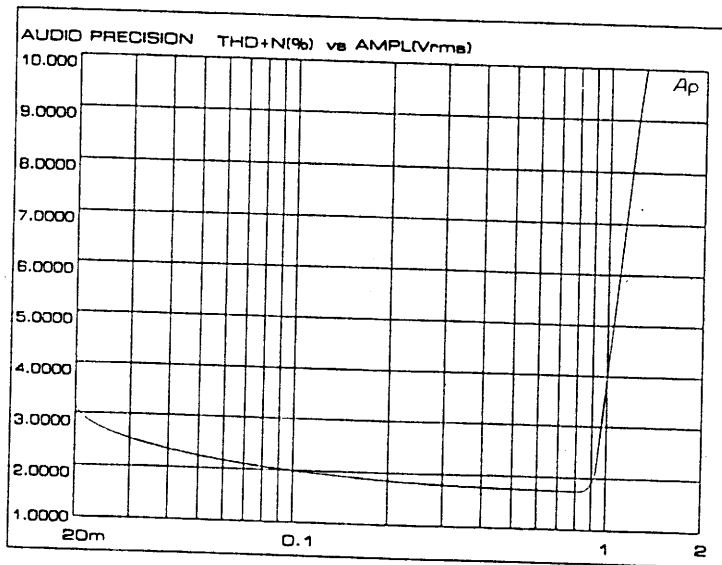



ITRI
ERSO

ES56030

ECHO SOUD PROCESSOR (8K)

16 PINS SOP PACKAGE SIZE

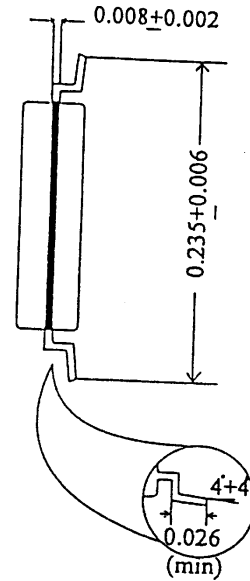
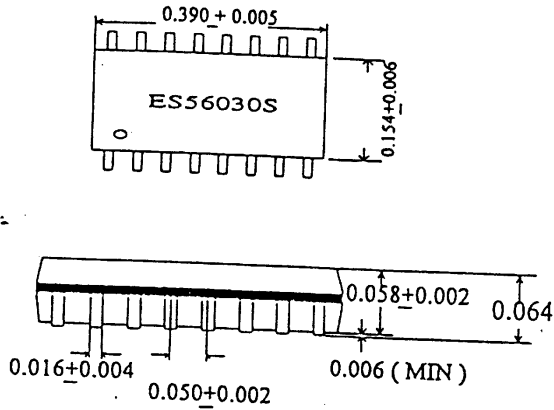

16 PINS DIP PACKAGE SIZE

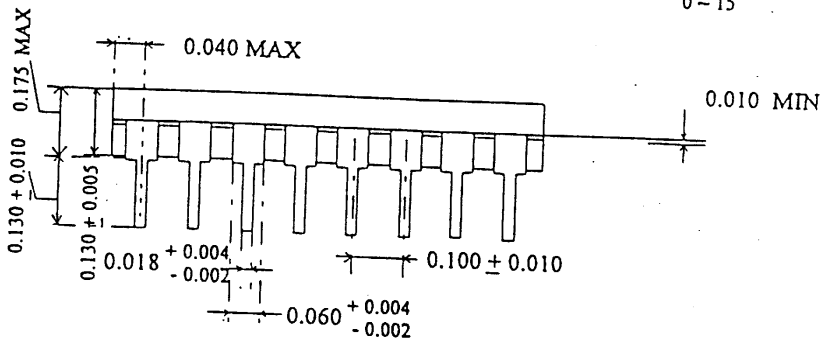
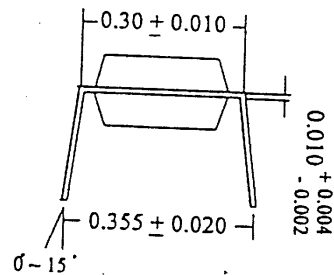
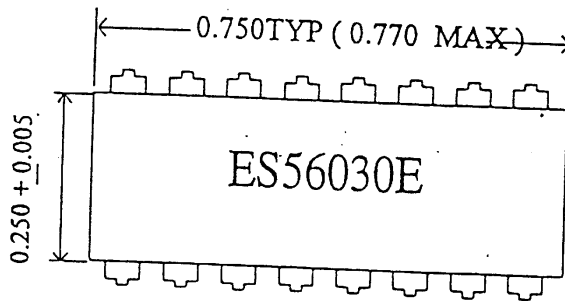

unit : inch